

Top 100  
Global  
Innovator  
for 10 years

# *GridSol* CARE *SMART LV SOLUTION*



Bluetooth

**LS** ELECTRIC

Reliability

- Power facility preventive and diagnostic services
- Ethernet network dualization
- Temperature monitoring and fire prevention
- Improved measurement accuracy



Reliability



Smart HV Solution  
PDPS

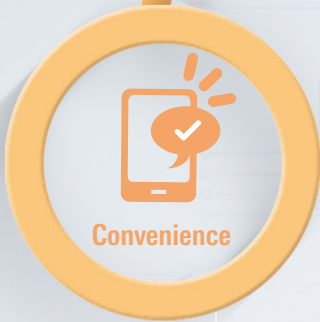

Convenience

Convenience

- Latest on-site management technology
- Real-time remote monitoring
- Real-time alarm service
- Integrated operation of existing systems

# GridSol CARE

Digital power facility integrated management service



Smart LV



**GridSol CARE is LS ELECTRIC's digital power facility integrated management service**  
**Provides energy management, facility operation efficiency, and maintenance**  
**convenience through smart switchboard and separate operation software,**  
**and also connects to SCADA and ultra high voltage diagnosis.**  
**We provide customized integration services.**



### Contents

1. Introducing GridSol CARE	02
2. Components and Benefits of Smart LV Solution	04
3. ACB / MCCB / MCB panel configuration	08
4. Specification introduction	
• Smart ACB	10
• Smart MCCB	48
• E TAG & MCB	72
• Smart LV Solution accessory device	78
• Smart LV Solution upper system	98
5. Major Achievements	108

#### Efficiency

- Energy information visualization
- Energy demand trend analysis
- Energy consumption prediction
- Provides periodic energy reports

# GridSol CARE Smart LV Solution

Smart LV Solution is LS ELECTRIC's unique smart switchboard solution that enhances measuring and monitoring by integrating IoT and digital technologies.



### Reliability – Prevent accidents in power facilities and reduce losses

- Remote monitoring and control of all circuit breakers from ACB to MCB
- Provides enhanced self-diagnostics in devices.
  - Contact life, number of opening/closing, temperature status, relay operation, battery, wiring status, memory, time, etc.
- Provides diagnostic and forecast services for power facilities.
  - Operation time, circuit breaker operation time, electrical/mechanical operation number, trip number, etc.
- Fire can be prevented through temperature monitoring.
  - TRIO : Temperature monitoring function for high-risk points.
  - Thermal CAM : Temperature monitoring function for hazardous areas and areas of interest.
- Improved measurement accuracy of Smart circuit breaker (STU, ETU models) (Class 1.0)
- Improved network stability by implementing Rapid Spanning Tree Protocol (RSTP).



### Convenience – Increased maintenance convenience and reduced commissioning time

- Auto discovery, Auto time sync
  - Provides automatic search and time synchronization for smart circuit breakers and instruments.
- Real-time monitoring of systems and devices
- On-site/remote monitoring of power facilities

Upper system	Function	Remark
Monitoring S/W (Cloud)	Cloud monitoring	Selection options
GridSol CARE Operation S/W	Remote monitoring and control	
Maintenance S/W	Project management, testing	
Panel HMI (7.0 inch)	On-site monitoring and control	
Smart Viewer (Mobile App.)	BLE : On-site monitoring	
	NFC : Checks the state just before power failure	

- Convenient F/W update function
  - Smart ACB, Smart MCCB : F/W update available in live or no power
  - Communication device : Remote F/W update
- Provides real-time alarm service when problems occur in systems and devices.
  - SMS, E-mail
  - Provides information on event type, time of occurrence, and location of power facilities



### Efficiency – Reduced energy consumption and cost

- Visualizes and provides data to intuitively understand energy information.
  - Graph (3D, bar, circle, strip, line, etc.), table
- Real-time information on energy can be checked by category.
  - Energy information : Power consumption, power demand, power quality, device information, peak, etc.
  - Category : Location, use, day, month, year, time zone, etc
- Provides real-time energy demand trend and analysis information.
- Provide regular reports for efficient energy management.
  - Project status, communication status, alarm/event, energy usage, system/device diagnostic information, etc.

	Line-up	Main functions
<b>Upper system</b>	GridSol CARE Monitoring S/W (Cloud)	<ul style="list-style-type: none"> <li>Provides LV panel monitoring function (anytime, anywhere) by managing data through the cloud server</li> <li>Provides real-time energy information such as device status, power consumption, quality, demand, and peak</li> <li>Provides E-mail, SMS functions (Events, reports)</li> </ul>
	GridSol CARE Operation S/W	<ul style="list-style-type: none"> <li>Provides monitoring and control of LV panel by managing data through local server</li> <li>Provides real-time energy information such as device status, power consumption, quality, demand, and peak</li> </ul>
	GridSol CARE Maintenance S/W	<ul style="list-style-type: none"> <li>Provides project engineering, device setting and control functions</li> <li>Relay setting and relay testing (Automatic generation of result reports)</li> </ul>
	Panel HMI (7.0 inch)	<ul style="list-style-type: none"> <li>7.0 inch TFT Color LCD</li> <li>Provides detailed information such as device status, communication status, hierarchical information, control, and events</li> </ul>
	Smart Viewer (Mobile App.)	<ul style="list-style-type: none"> <li>Smart circuit breaker on-site monitoring (BLE) and immediately before event check (NFC)</li> </ul>
<b>Communication device</b>	Gateway	<ul style="list-style-type: none"> <li>Auto discovery, auto time sync</li> <li>Provides Rapid Spanning Tree Protocol (RSTP) function</li> <li>Provides infrared camera monitoring and web service support</li> </ul>
	Ethernet Converter (RSTP)	<ul style="list-style-type: none"> <li>Provides E-mail</li> <li>Provides RSTP (Rapid Spanning Tree Protocol) function</li> </ul>
	E COLLECTOR	<ul style="list-style-type: none"> <li>Collects electricity measurement data of small sensing module (E TAG) by wireless communication</li> <li>Fast registration and Web service support through auto discovery function</li> </ul>
<b>Accessory device</b>	M LINK	<ul style="list-style-type: none"> <li>MCB/MCCB On/off/trip status monitoring and on/off control</li> <li>Number of contacts: DI 6 points, DO 4 points, AI 1 point</li> </ul>
	TRIO	<ul style="list-style-type: none"> <li>ACB temperature monitoring (7-Segment)</li> <li>ACB On/off control and contact monitoring</li> </ul>
	Thermal CAM	<ul style="list-style-type: none"> <li>Real-time temperature change monitoring and alarm of facilities and devices installed on site</li> </ul>
	T Connection Module	<ul style="list-style-type: none"> <li>Provides RS-485 Multi-Drop connection convenience</li> <li>Provides termination processing function</li> </ul>
	DC Power Module	<ul style="list-style-type: none"> <li>DC 24V output</li> <li>5 types according to input and output specifications</li> </ul>
	i-Tester	<ul style="list-style-type: none"> <li>Saves current relay test and test history results (Used for test result report)</li> </ul>
	Portable Battery & Trip Module	<ul style="list-style-type: none"> <li>Supplies DC power to Smart MCCB</li> <li>Checks Smart MCCB trip operation</li> </ul>
<b>Circuit breaker</b>	Smart ACB	<ul style="list-style-type: none"> <li>Susol &amp; Metasol ACB applied with Smart Trip Unit (STU)</li> <li>Equipped with IoT function and upgraded measurement accuracy, measurement items, relay function</li> </ul>
	Smart MCCB	<ul style="list-style-type: none"> <li>Susol MCCB applied with ETU (Electronic Trip Unit)</li> <li>Equipped with IoT function and upgraded measurement accuracy, measurement items, relay function</li> </ul>
	MCB	<ul style="list-style-type: none"> <li>BK63H Series</li> </ul>
<b>Measurement device</b>	GIMAC1000	<ul style="list-style-type: none"> <li>Provides voltage, current, power and power measurement and Harmonics and THD, TDD functions for voltage, current</li> <li>Provides Rapid Spanning Tree Protocol (RSTP) function</li> </ul>
	E TAG	<ul style="list-style-type: none"> <li>Tag type small sensing module for measuring electricity (Voltage/current/power/power factor/frequency)</li> <li>Supports wireless communication to simplify wiring within the panel (Interface with E COLLECTOR and wireless communication)</li> </ul>
	DMPi	<ul style="list-style-type: none"> <li>Current measurement and protection</li> <li>Provides various returns (Manual/auto/electrical return) functions</li> </ul>
	MMP	<ul style="list-style-type: none"> <li>Measurement of current, voltage and power and protection of power factor</li> <li>Applies various motor starting methods with one model</li> </ul>

**GridSol CARE**

# Smart LV Solution

Smart LV Solution is LS ELECTRIC's unique smart switchboard solution that enhances measuring and monitoring by integrating IoT and digital technologies.



Reliability

### Reliability – Prevent accidents in power facilities and reduce losses

- Remote monitoring and control of all circuit breakers from ACB to MCB
- Provides enhanced self-diagnostics in devices.
  - Contact life, number of opening/closing, temperature status, relay operation, battery, wiring status, memory, time, etc.
- Provides diagnostic and forecast services for power facilities.
  - Operation time, circuit breaker operation time, electrical/mechanical operation number, trip number, etc.
- Fire can be prevented through temperature monitoring.
  - TRIO : Temperature monitoring function for high-risk points.
  - Thermal CAM : Temperature monitoring function for hazardous areas and areas of interest.
- Improved measurement accuracy of Smart circuit breaker (STU, ETU models) (Class 1.0)
- Improved network stability by implementing Rapid Spanning Tree Protocol (RSTP).

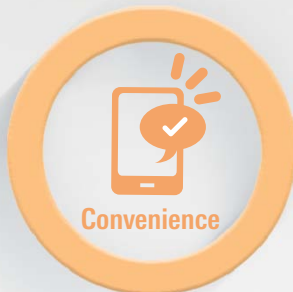

Convenience

### Convenience – Increased maintenance convenience and reduced commissioning time

- Auto discovery, Auto time sync
  - Provides automatic search and time synchronization for smart circuit breakers and instruments.
- Real-time monitoring of systems and devices
- On-site/remote monitoring of power facilities

Upper system	Function	Remark
Monitoring S/W (Cloud)	Cloud monitoring	Selection options
GridSol CARE Operation S/W	Remote monitoring and control	
Maintenance S/W	Project management, testing	
Panel HMI (7.0 inch)	On-site monitoring and control	
Smart Viewer (Mobile App.)	BLE : On-site monitoring	
	NFC : Checks the state just before power failure	

- Convenient F/W update function
  - Smart ACB, Smart MCCB : F/W update available in live or no power
  - Communication device : Remote F/W update
- Provides real-time alarm service when problems occur in systems and devices.
  - SMS, E-mail
  - Provides information on event type, time of occurrence, and location of power facilities



Efficiency

### Efficiency – Reduced energy consumption and cost

- Visualizes and provides data to intuitively understand energy information.
  - Graph (3D, bar, circle, strip, line, etc.), table
- Real-time information on energy can be checked by category.
  - Energy information : Power consumption, power demand, power quality, device information, peak, etc.
  - Category : Location, use, day, month, year, time zone, etc
- Provides real-time energy demand trend and analysis information.
- Provide regular reports for efficient energy management.
  - Project status, communication status, alarm/event, energy usage, system/device diagnostic information, etc.

### Smart SWGR Panel

### Energy Monitoring Panel

GIMAC1000

Panel HMI (7.0 inch)



Smart ACB



Smart MCCB

DMPi

MMP

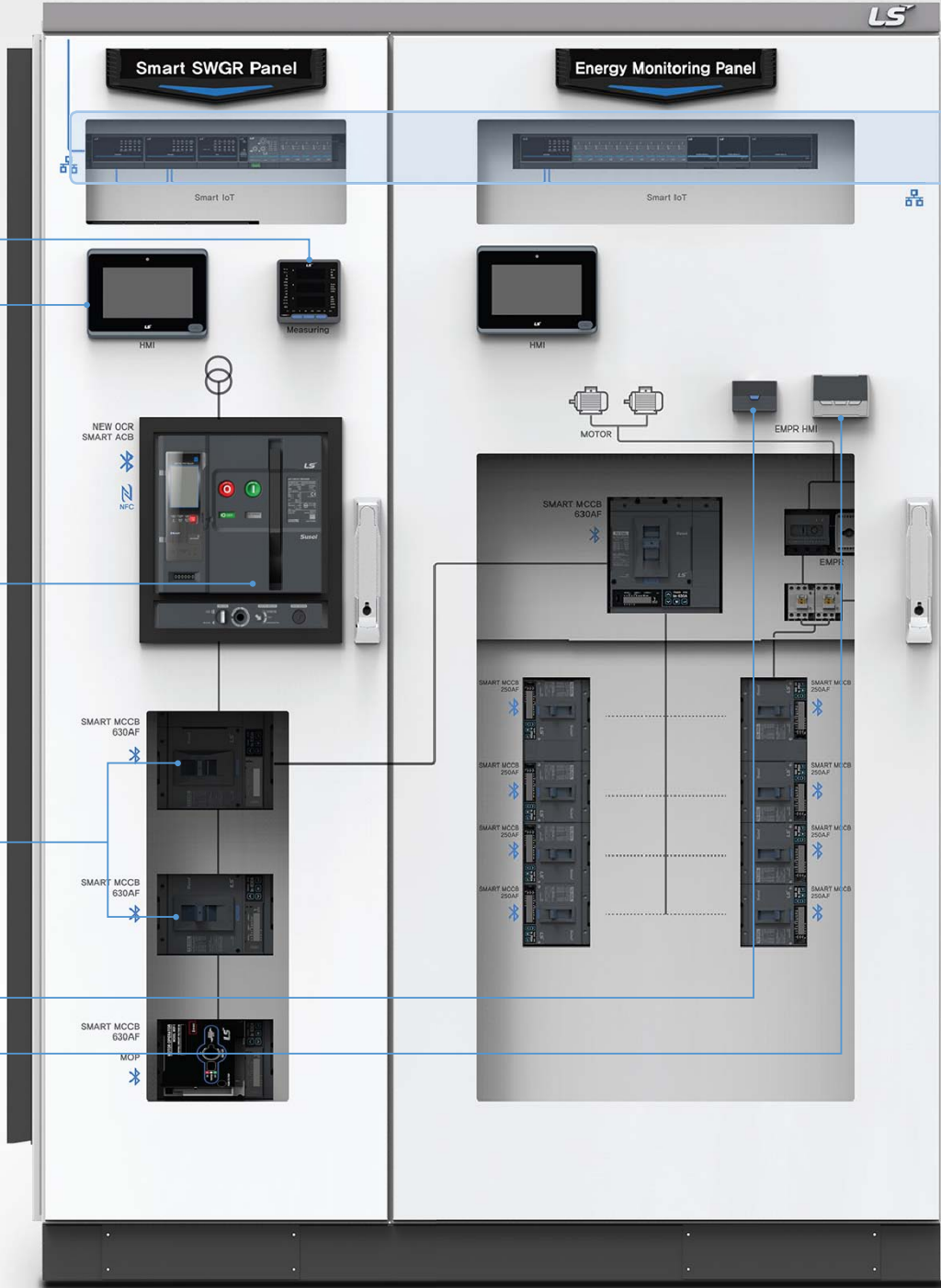

# GridSol CARE

LS

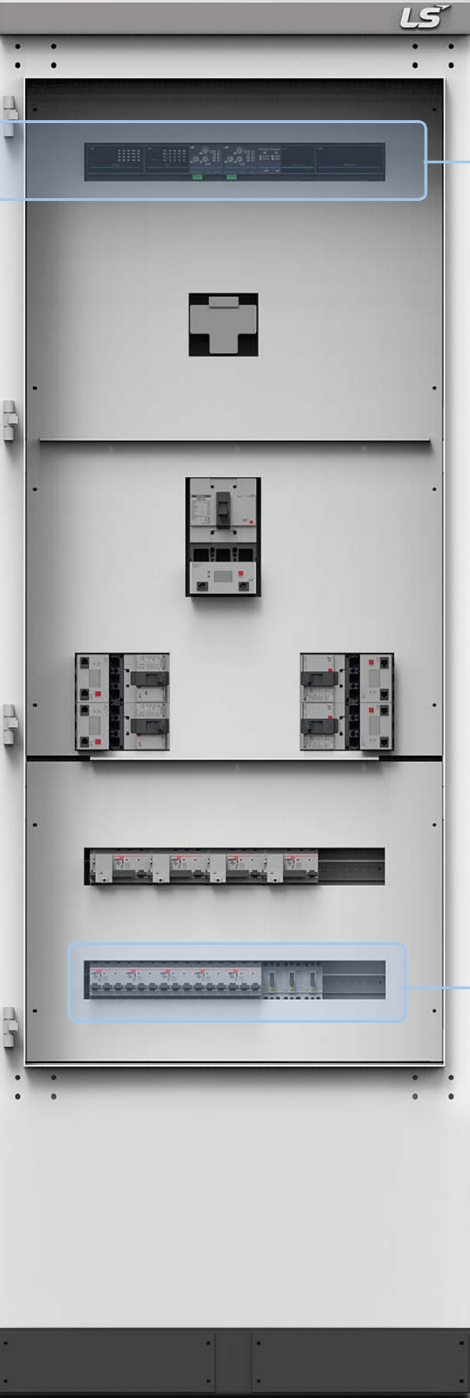

Gateway



Ethernet Converter



TRIO



M LINK



DC Power Module



T Connection Module



E COLLECTOR



E TAG



MCB



	Line-up	Main functions
<b>Upper system</b>	GridSol CARE Monitoring S/W (Cloud)	<ul style="list-style-type: none"> <li>Provides LV panel monitoring function (anytime, anywhere) by managing data through the cloud server</li> <li>Provides real-time energy information such as device status, power consumption, quality, demand, and peak</li> <li>Provides E-mail, SMS functions (Events, reports)</li> </ul>
	GridSol CARE Operation S/W	<ul style="list-style-type: none"> <li>Provides monitoring and control of LV panel by managing data through local server</li> <li>Provides real-time energy information such as device status, power consumption, quality, demand, and peak</li> </ul>
	GridSol CARE Maintenance S/W	<ul style="list-style-type: none"> <li>Provides project engineering, device setting and control functions</li> <li>Relay setting and relay testing (Automatic generation of result reports)</li> </ul>
	Panel HMI (7.0 inch)	<ul style="list-style-type: none"> <li>7.0 inch TFT Color LCD</li> <li>Provides detailed information such as device status, communication status, hierarchical information, control, and events</li> </ul>
	Smart Viewer (Mobile App.)	<ul style="list-style-type: none"> <li>Smart circuit breaker on-site monitoring (BLE) and immediately before event check (NFC)</li> </ul>
<b>Communication device</b>	Gateway	<ul style="list-style-type: none"> <li>Auto discovery, auto time sync</li> <li>Provides Rapid Spanning Tree Protocol (RSTP) function</li> <li>Provides infrared camera monitoring and web service support</li> </ul>
	Ethernet Converter (RSTP)	<ul style="list-style-type: none"> <li>Provides E-mail</li> <li>Provides RSTP (Rapid Spanning Tree Protocol) function</li> </ul>
	E COLLECTOR	<ul style="list-style-type: none"> <li>Collects electricity measurement data of small sensing module (E TAG) by wireless communication</li> <li>Fast registration and Web service support through auto discovery function</li> </ul>
<b>Accessory device</b>	M LINK	<ul style="list-style-type: none"> <li>MCB/MCCB On/off/trip status monitoring and on/off control</li> <li>Number of contacts: DI 6 points, DO 4 points, AI 1 point</li> </ul>
	TRIO	<ul style="list-style-type: none"> <li>ACB temperature monitoring (7-Segment)</li> <li>ACB On/off control and contact monitoring</li> </ul>
	Thermal CAM	<ul style="list-style-type: none"> <li>Real-time temperature change monitoring and alarm of facilities and devices installed on site</li> </ul>
	T Connection Module	<ul style="list-style-type: none"> <li>Provides RS-485 Multi-Drop connection convenience</li> <li>Provides termination processing function</li> </ul>
	DC Power Module	<ul style="list-style-type: none"> <li>DC 24V output</li> <li>5 types according to input and output specifications</li> </ul>
	i-Tester	<ul style="list-style-type: none"> <li>Saves current relay test and test history results (Used for test result report)</li> </ul>
	Portable Battery & Trip Module	<ul style="list-style-type: none"> <li>Supplies DC power to Smart MCCB</li> <li>Checks Smart MCCB trip operation</li> </ul>
<b>Circuit breaker</b>	Smart ACB	<ul style="list-style-type: none"> <li>Susol &amp; Metasol ACB applied with Smart Trip Unit (STU)</li> <li>Equipped with IoT function and upgraded measurement accuracy, measurement items, relay function</li> </ul>
	Smart MCCB	<ul style="list-style-type: none"> <li>Susol MCCB applied with ETU (Electronic Trip Unit)</li> <li>Equipped with IoT function and upgraded measurement accuracy, measurement items, relay function</li> </ul>
	MCB	<ul style="list-style-type: none"> <li>BK63H Series</li> </ul>
<b>Measurement device</b>	GIMAC1000	<ul style="list-style-type: none"> <li>Provides voltage, current, power and power measurement and Harmonics and THD, TDD functions for voltage, current</li> <li>Provides Rapid Spanning Tree Protocol (RSTP) function</li> </ul>
	E TAG	<ul style="list-style-type: none"> <li>Tag type small sensing module for measuring electricity (Voltage/current/power/power factor/frequency)</li> <li>Supports wireless communication to simplify wiring within the panel (Interface with E COLLECTOR and wireless communication)</li> </ul>
	DMPi	<ul style="list-style-type: none"> <li>Current measurement and protection</li> <li>Provides various returns (Manual/auto/electrical return) functions</li> </ul>
	MMP	<ul style="list-style-type: none"> <li>Measurement of current, voltage and power and protection of power factor</li> <li>Applies various motor starting methods with one model</li> </ul>

## ACB/MCCB/MCB panel configuration

### Upper system

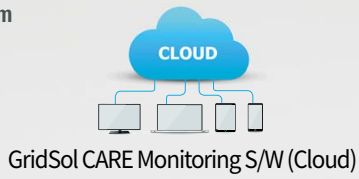

### Communication device



### Accessory device



### Circuit breaker & measurement device

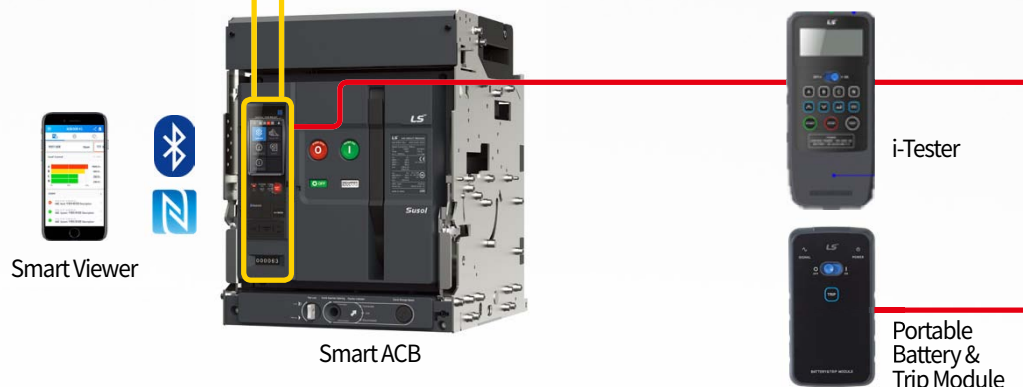

### Main panel

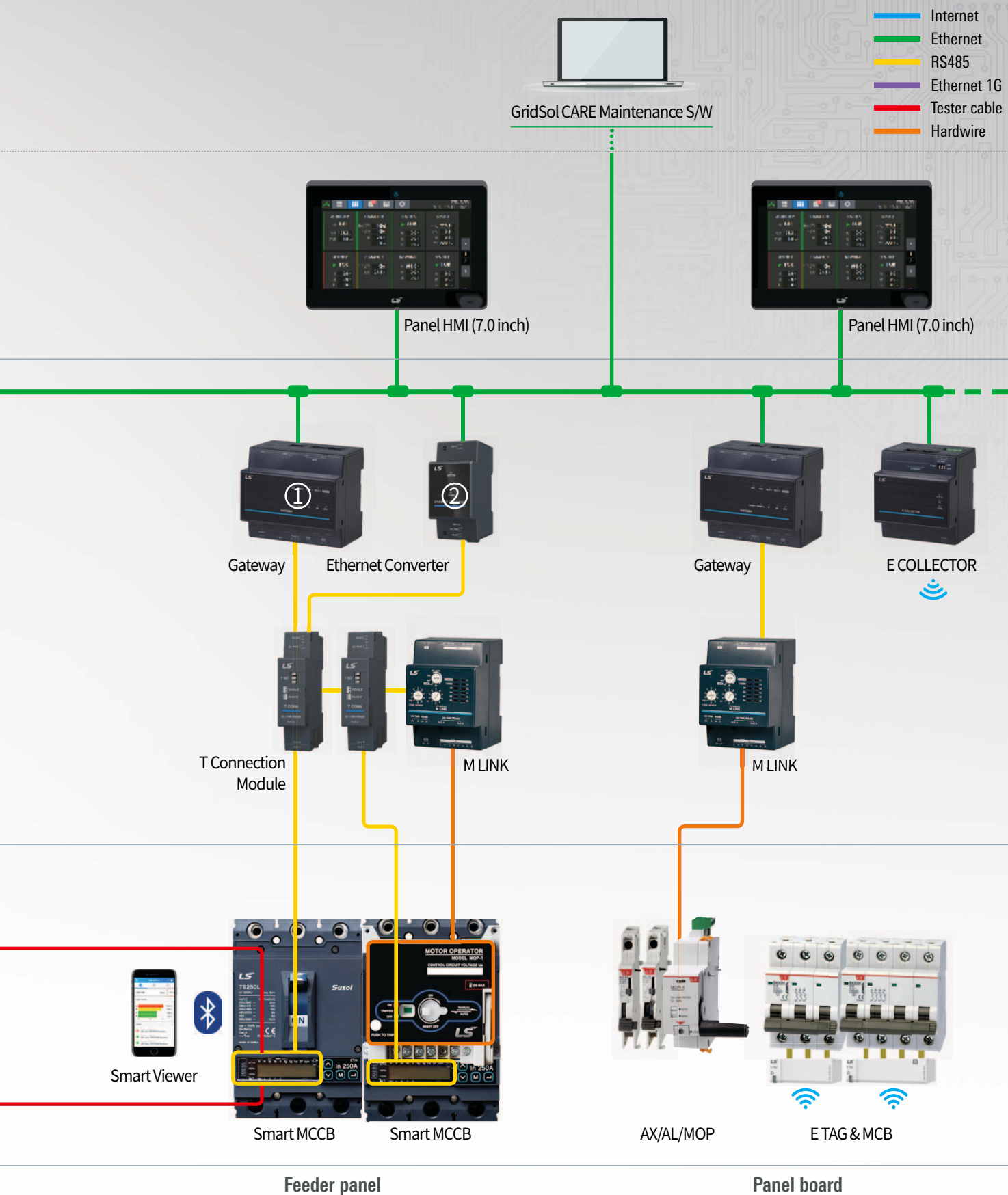

# Smart Air Circuit Breakers

Smart ACB is a large-capacity breaking, multifunctional device. It is a Susol/Metasol ACB applied with a digital trip relay STU (Smart Trip Unit) with built-in IoT communication function for measurement, analysis, diagnosis and Smart LV implementation other than relay.





# Smart ACB

---

- 1. Overview**
  - Susol ACB Overview ..... 12
  - Metasol ACB Overview ..... 14
  - STU (Smart Trip Unit) Overview ..... 16
- 2. Features**
  - ACB with STU (Smart Trip Unit) Features ..... 18
- 3. Model selecting guide**
  - Susol ACB model numbering (Product selection) ..... 22
  - Metasol ACB model numbering (Product selection) ..... 24
  - Susol UL ACB model numbering ..... 26
  - Susol ACB Cradle model numbering (Product selection) ..... 28
  - Metasol ACB Cradle model numbering (Product selection) ..... 28
  - Susol UL ACB Cradle model numbering ..... 29
  - Smart Trip Unit model numbering (Product selection) ..... 30
- 4. Rated specifications**
  - Susol ACB Rated specifications ..... 32
  - Metasol ACB Rated specifications ..... 34
  - Susol UL ACB Rated specifications ..... 36
- 5. Smart Trip Unit** ..... 38

---

# Susol ACB Overview



## Family

As the world's best large-capacity breaking, multifunctional device, Susol ACB Series can apply digital trip relay STU (Smart Trip Unit) with built-in IoT communication function for measurement, analysis, diagnosis, and Smart LV implementation other than relay. It is suitable for important facilities, since the Arc Cover for securing Arc Space Zero performance is installed.

# 85kA

# 100kA

### AH-06~20D

06	630AF
08	800AF
10	1000AF
13	1250AF
16	1600AF
20	2000AF

Icu=Ics=85kA/500Vac  
W=334(3p), 419(4p)mm

### AH-06~40E

06	630AF	20	2000AF
08	800AF	25	2500AF
10	1000AF	32	3200AF
13	1250AF	40	4000AF
16	1600AF		

Icu=Ics=100kA/500Vac  
W=412(3p), 527(4p)mm

4000~6300 AF



## Full line-up & Compact

Up to 6300A, Susol ACB provides fully lined-up 3 frame.  
For each frame, there is just one size, which is smaller and more compact.  
It makes it possible for you to design the optimized volume panel.

# 150kA

### AH-40~63G

40	4000AF
50	5000AF
63	6300AF

Icu=Ics=150kA/500Vac  
W=785(3p), 1015(4p)mm

- The highest breaking capacity: 150kA (6300AF at 500Vac)
- 3 ampere frame sizes: 2000/4000/6300AF
- N phase current conducting capacity: 100%

# Metasol ACB Overview

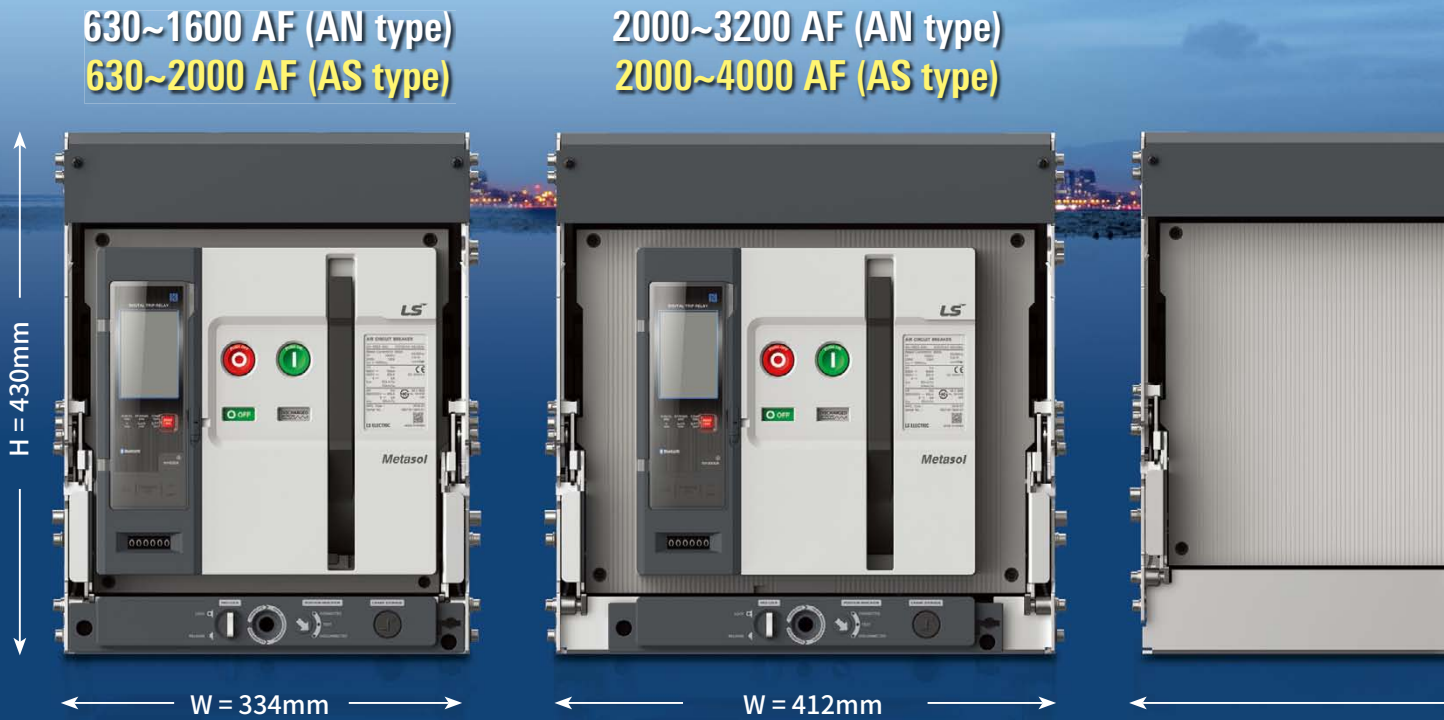

## Family

As a large-capacity breaking, multifunctional device, Metasol ACB Series is able to apply digital trip relay STU (Smart Trip Unit) with built-in IoT communication function for measurement, analysis, diagnosis, and Smart LV implementation other than relay. It is a highly customized device that maximizes the range of device selection by size and rating by diversifying small and medium capacity (less than 3200AF) models and various deployments of large capacity (more than 4000AF) models.

70kA (65kA) ..... 85kA (70kA) .....

### AN-06~16D

06	630AF
08	800AF
10	1000AF
13	1250AF
16	1600AF

Icu=Ics=65kA/500Vac  
W=334(3p), 419(4p)mm

### AS-06~20D

06	630AF
08	800AF
10	1000AF
13	1250AF
16	1600AF
20	2000AF

Icu=Ics=70kA/500Vac  
W=334(3p), 419(4p)mm

### AN-20~32E

20	2000AF
25	2500AF
32	3200AF

Icu=Ics=70kA/500Vac  
W=412(3p), 527(4p)mm

### AS-20~40E

20	2000AF
25	2500AF
32	3200AF
40	4000AF

Icu=Ics=85kA/500Vac  
W=412(3p), 527(4p)mm



4000  
~5000 AF (AS type)

4000~6300 AF (AS type)



## Full line-up & Compact

Up to 6300A, Metasol ACB provides fully lined-up 4 frame.  
For each frame, there is just one size, which is smaller and more compact.  
It makes it possible for you to design the optimized volume panel.

..... 100kA ..... 120kA

### AS-50F

40	4000AF
50	5000AF

Icu=Ics=100kA/500Vac  
W=629(3p), 799(4p)mm

### AS-40~63G

40	4000AF
50	5000AF
63	6300AF

Icu=Ics=120kA/500Vac  
W=785(3p), 1015(4p)mm

- The highest breaking capacity:  
150kA (6300AF at 500Vac)
- 4 ampere frame sizes:  
2000/4000/5000/6300AF
- N phase current conducting capacity: 100

# Smart Trip Unit Overview

## Smart Trip Unit (Trip Relay)

It is a smart trip unit that provides the world's highest level of measurement accuracy, relay function, and IoT communication function, and is a relay interlocked with the mechanism (low voltage circuit breaker body). It expands and improves the ACB's breaking performance (high-speed short-circuit breaking characteristic) and increases the ACB life (increasing marking capacity).



## Smart Trip Unit



- Secures relay operation safety through the instrument-level measurement accuracy (current/voltage 0.5%, power class 1.0)
- Prevention of mis-trip through powerful self-diagnosis functions such as CT disconnection check, contact wear rate, internal temperature monitoring, and quick response through alarm
- Secures Smart Panel Solution through **ICT convergence technology** (Service is accessible anytime, anywhere)
- Speedily changes the relay setting value when changing from commercial power to power generation according to S type relay setting Group A/B (A→B)
- **Power supply for checking and setting internal data of STU (N/A/P/S) at a short distance through USB communication**

## Serializes STU's trip relay by function

The trip relay series for each use and function are maximized and the user's convenience is maximized by easy attachment and detachment.

	<p><b>N type</b></p> <ul style="list-style-type: none"> <li>• Device operation through self-power</li> <li>• Current relay function</li> <li>• <b>Supports USB communication</b></li> <li>• Supports NFC communication (Standard)</li> </ul>		<p><b>P type</b></p> <ul style="list-style-type: none"> <li>• Device operation through self-power</li> <li>• Device operation via AC or DC</li> <li>• Current/voltage/frequency/power relay function</li> <li>• 3.5" Graphic Display</li> <li>• DO output</li> <li>• Supports USB communication</li> <li>• Supports RS485 communication</li> <li>• Supports BLE communication (Option)</li> </ul>
	<p><b>A type</b></p> <ul style="list-style-type: none"> <li>• Device operation through self-power</li> <li>• Device operation via AC or DC</li> <li>• Current relay function</li> <li>• Segment LCD Display</li> <li>• DO output</li> <li>• Supports USB communication</li> <li>• Supports RS485 communication</li> </ul>		<p><b>S type</b></p> <ul style="list-style-type: none"> <li>• Device operation through self-power</li> <li>• Device operation via AC or DC</li> <li>• Current/voltage/frequency/power relay function</li> <li>• 3.5" Graphic Display</li> <li>• DO output</li> <li>• Relay setting to group A/B</li> <li>• Supports short-range USB communication</li> <li>• Supports RS485 communication</li> <li>• Supports NFC/BLE communication</li> </ul>

# ACB with STU (Smart Trip Unit) Features

## Upgraded performance compared to existing OCR

### Improved measurement accuracy

Type	Susol ACB OCR P/S	Smart Trip Unit (STU)			
		N	A	P	S
Measurement accuracy	Current	6%	0.5%		0.5%
	Voltage	3%	—		0.5%
	Power	10%	—		Class 1.0
	Frequency	0.05Hz (50,60Hz device classification)	50, 60 Hz device classification		0.1% (10~200Hz)

- Measurement accuracy through calibration using voltage, current, and power reference  
(Current/Voltage : 0.5%, Power : Class 1.0) Satisfaction
- Improved resolution using 16bit ADC converter

### Measurement items & relay function extension

1. Based on S type, equipped with a total of 29 types and 58 relay functions
2. Relay setting grouping and change function (Gtoup A/B)  
: Relay group setting is changed quickly in parallel feeding situation where relay setting needs to be changed. (Group A → B)
3. ERMS (Energy Reduction Management System) function  
: As a function to sensitively change the relay setting for the safety of a field electrical engineer, it is a safety related function required by the American market (L/S1/S2/IG//LN)
4. ZSI (Zone Select Interlock) function  
: A function to operate the upstream circuit breaker closest to the accident point first by using ZSI Input DI and ZSI Output DO
5. Start-up function  
: Prevents malfunction of relay element by in-rush current generated when starting motor and Transformers
6. Stores 255 system events, 127 fault events and 6 accident waves  
: Trip Wave saves 4 cycles before an accident + 4 cycles after an accident

**Safe self-diagnosis function**

Quick maintenance by adding powerful self-diagnosis function to prevent mis-trip and through alarm

		N type	A type	P type	S type
Self-diagnosis	LED	RUN/AL LED flashing (Red ↔ Blue flashing)			
	LCD		Displays the corresponding segment or error number	Can be checked on the self-diagnosis screen	
	List	<ul style="list-style-type: none"> <li>• <b>Contact Wear Alarm :</b> Occurs when the contact wear rate is over 80%</li> <li>• <b>Electrical Open Count Over Alarm :</b> Occurs when the electrical open count exceeds 80% of the allowable electrical open count</li> <li>• <b>Mechanical Open Count Over Alarm :</b> Occurs when the mechanical open count exceeds 80% of the allowable mechanical open count</li> <li>• <b>CT disconnection error :</b> Occurs when CT disconnection occurs (monitoring for each phase), breaks relay function related to disconnection such as G, UP, IU, etc.</li> <li>• <b>Over Heat Error :</b> Occurs when CPU internal temperature N/A type exceeds 100°C and P/S type exceeds 115°C.</li> <li>• <b>MTD Fail :</b> Occurs when STU is not assembled with MTD or trip coil disconnection occurs (wiring check)</li> <li>• <b>Battery Low Alarm :</b> Occurs when the internal battery is not inserted or when the battery voltage is low</li> <li>• <b>Rating Plug Unattached or Error :</b> Occurs when rating plug is not assembled or when there is rating plug error</li> <li>• <b>Ampere Frame Error :</b> Occurs when the value of rating plug is not within 45%~100% of AF</li> <li>• <b>Factory Cfg Error :</b> Occurs when the factory mode setting is entered incorrectly</li> <li>• <b>Device Type Error :</b> Occurs when the rating plug information and CT information are different</li> <li>• <b>RTC Error :</b> Occurs when an error occurs in the internal RTC information</li> <li>• <b>Memory Error :</b> Occurs when corruption occurs in the redundant internal settings stored in the internal non-volatile memory</li> </ul>			

# ACB with STU(Smart Trip Unit) Features

## Increased user convenience

### Uninterrupted device update & non-powered device setting

- By using USB interface, STU Program update is possible without a power outage in the live state, and STU can be set and updated even when the power is not supplied.



Uninterrupted device update & non-powered device setting

### VDM and frequency tracking technology

- With a built-in VDM for voltage measurement, it can save the installation space of the distribution panel. It is also equipped with frequency tracking technology that maintains measurement and relay accuracy even at variable frequencies from 10 Hz to 200 Hz (Able to respond to renewable energy markets such as wind power and waterpower).
- We have Internal and external type VDM, and the external type is used when the primary and secondary sides of the ACB are reversed and the location of the inspection of the VDM is differently in case of 2-Stage ACB.

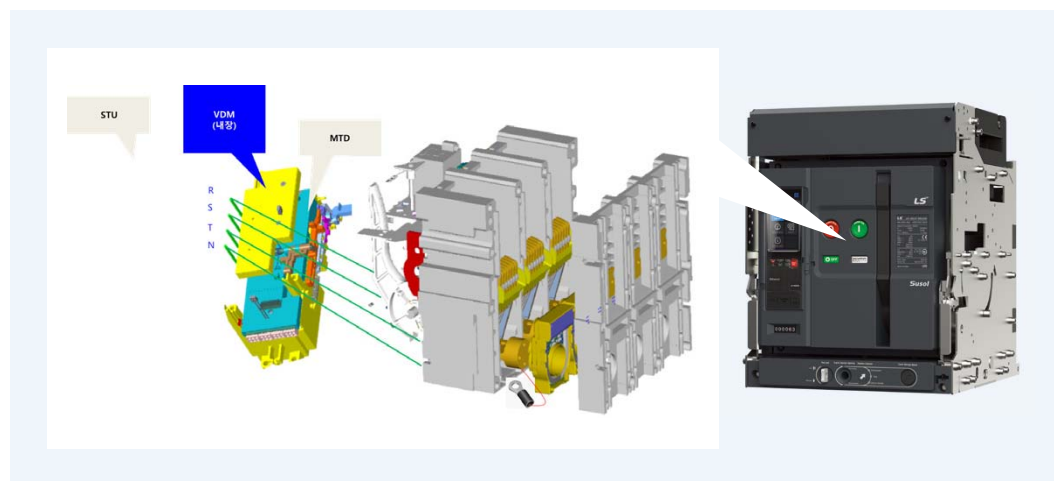

- Note1) Be sure to use a shielding wire for the secondary wiring of the Voltage module.  
Note2) The maximum length of use is less than 3.5m.  
Note3) If you want an external VDM, please insert '(-V)' at the end of the full ordering.

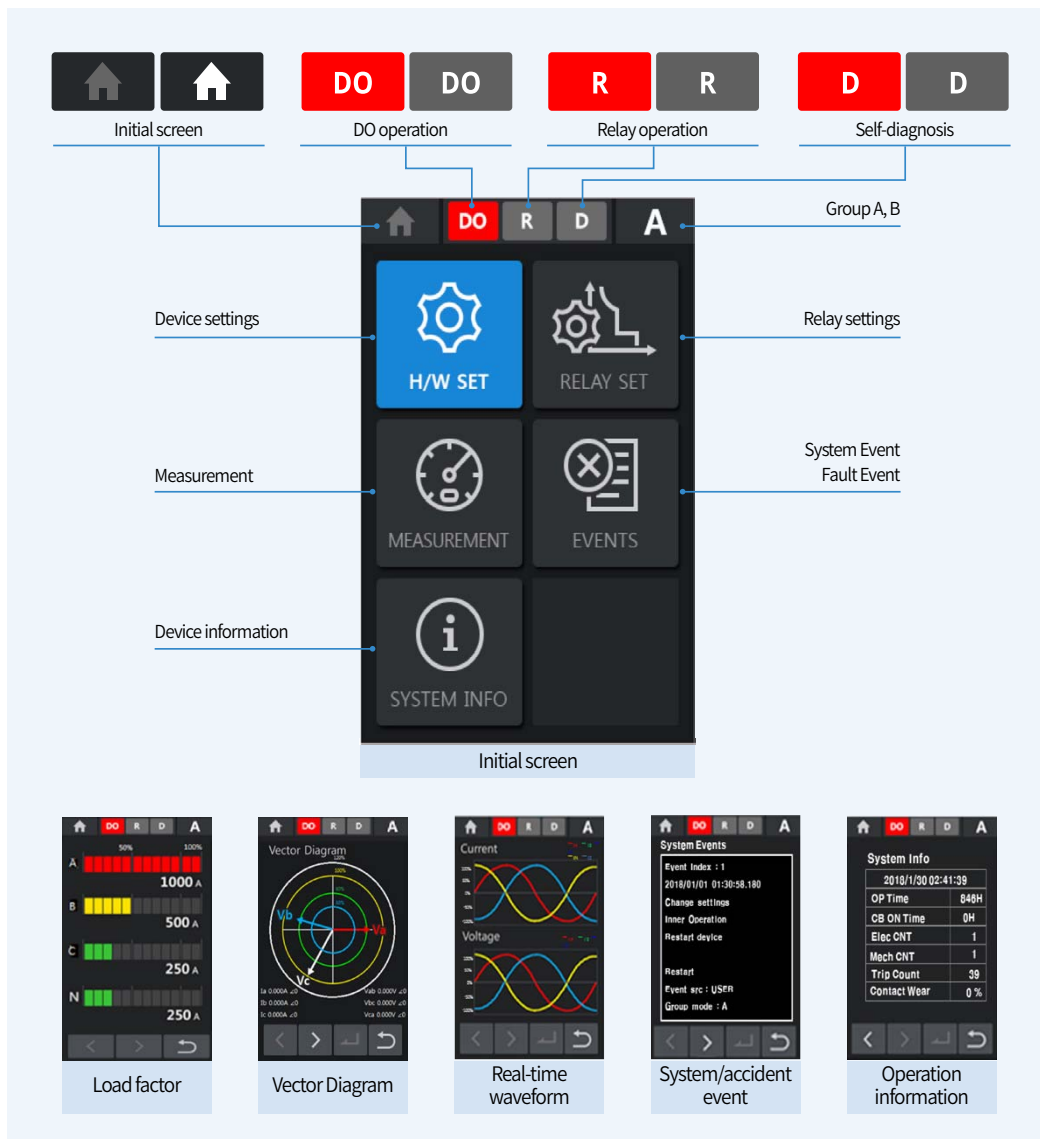

### 3.5" Touch Graphic LCD applied

- By applying Color Graphic LCD & Touch panel in P and S types, it improves the convenience and visibility of device use.



### Built-in IoT function

- It is possible to check and share device information on a smartphone by interworking with a mobile App. through BLE and NFC communication.

Type	Specifications
 NFC	(1) Collects STU last trip information through smart phone in non-powered state (2) Communication distance : 10mm or less
 BLE	(1) All information of the device can be accessed through the smart phone while the power is supplied. (2) Communication distance : within 4m

# Model selecting guide

## Susol ACB model numbering (Product selection)

### Body and accessories

<b>AH</b>	<b>10</b>	<b>D</b>	<b>3</b>	<b>10</b>	<b>A</b>
<b>Type</b>	<b>Ampere Frame</b>	<b>Frame sizes &amp; phase array</b>	<b>No. of pole</b>	<b>Rated current (CT Spec.)</b>	<b>Connections</b>
Susol ACB	06 630AF 08 800AF 10 1000AF 13 1250AF 16 1600AF 20 2000AF	630 ~ 2000AF D 3P/4P Standard ABC (N) W 630~2000AF 4P Inverse type (N) ABC	3 3P(D) 4 4P(D, W)	00 Without STU & CT 02 200A 04 400A 06 630A 08 800A 10 1000A 13 1250A 16 1600A 20 2000A	Draw-out type A Automatic connection Fixed type H Horizontal type V Vertical type M Horizontal Vertical N Mixed type Vertical Horizontal P Front type
<b>DH</b> Switch Disconnector	* 2000AF only offers with vertical type mounting terminals(Busbar).				



06 630AF 08 800AF 10 1000AF 13 1250AF 16 1600AF 20 2000AF 25 2500AF 32 3200AF 40 4000AF	E 630 ~ 4000AF 3P/4P Standard ABC (N) X 630 ~ 4000AF 4P Reverse phase type(N) ABC	3 3P(E) 4 4P(E, X)	00 No STU & CT 02 200A 04 400A 06 630A 08 800A 10 1000A 13 1250A 16 1600A 20 2000A 25 2500A 32 3200A 40 4000A
*4000AF only offers with vertical type mounting terminals(Busbar).			



40 4000AF 50 5000AF 63 6300AF	G 4000/5000/6300AF 3P/4P Standard ABC (N) Z 4000/5000/6300AF 4P Reverse phase type(N) ABC	3 3P(G) 4 4P(G, Z)	00 No STU & CT 40 4000A 50 5000A 63 6300A
-------------------------------------	--	-----------------------	--

Note 1) AH-20D, AH-40E types are equipped with vertical-only terminals.

In case of F/Y/G/Z Frame size, front type & mixed type connection is not available.

2) In case of DH type Switch Disconnector, the rated current (CT Spec.) will be applied 00

3) DN models are selectable up to 3200AF and DS models up to 4000AF.



M1	D1	D1	AX	SS1	U1	AL
Motor rated voltage	Closing coil rated voltage	Shunt coil rated voltage	Aux.contact & charging types	STU	UVT coil rated voltage	
MA Without Motor	D0 Without Closing coil	D0 Without Shunt coil	AX Standard type OFF - Charge 3a3b	Refer to page 27	U0 Without UVT coil	
M1 AC/DC 100V ~ 130V	D1 AC/DC 100V ~ 130V	D1 AC/DC 100V ~ 130V	AC Standard type ON - Charge 3a3b		U1 AC/DC 100V ~ 130V	
M2 AC/DC 200V ~ 250V	D2 AC/DC 200V ~ 250V	D2 AC/DC 200V ~ 250V	BX Standard type OFF - Charge 5a5b		U2 AC/DC 200V ~ 250V	
M3 DC 125V	D3 DC 125V	D3 DC 125V	BC Standard type ON - Charge 5a5b		U3 DC 125V	
M4 DC 24V ~ 30V	D4 DC 24V ~ 30V	D4 DC 24V ~ 30V	HX High capacity OFF - Charge 5a5b		U4 DC 24V ~ 30V	
M5 DC 48V ~ 60V	D5 DC 48V ~ 60V	D5 DC 48V ~ 60V	HC High capacity ON - Charge 5a5b		U5 DC 48V ~ 60V	
M6 AC 380V ~ 415V	D6 AC 380V ~ 480V	D6 AC 380V ~ 480V	CC Standard type ON - Charge 6a6b		U6 AC 380V ~ 480V	
M7 AC 440V ~ 480V	D7 AC 48V	D7 AC 48V	JC High capacity ON - Charge 6a6b		U7 AC 48V	
M8 AC 48V			GX High capacity OFF - Charge 3a3b			
			GC High capacity ON - Charge 3a3b			
			TX TCS OFF - Charge 4a4b			
			TC TCS ON - Charge 5a5b			

\* UVT Delay module is available over AC / DC 48V

Option		
Option	Type name	Option description
AL	AL1 + MRB	
A1	AL1 + MRB + RES(AC/DC 110~130V) *AC only	
A2	AL1 + AL2 + MRB	
A3	AL1 + MRB + RES(AC/DC 110~125V) *DC only	
A4	AL1 + MRB + RES(AC/DC 200~250V) *AC only	
A5	AL1 + MRB + AUTO RESET	
A6	AL1 + AL2 + MRB + AUTO RESET	
A7	AL1 + MRB + RES(AC/DC 110~125V) + AUTO RESET *DC전용	
A8	AL1 + MRB + RES(AC/DC 200~250V) + AUTO RESET *AC전용	
A9	AL1 + MRB + RES(AC/DC 110~130V) + AUTO RESET *AC전용	
Y2	AL1 + AL2 + MRB(2b contact)	
Y6	AL1 + AL2 + MRB + AUTO RESET(2b contact)	
Z2	AL1 + AL2 + MRB(1a1b contact)	
Z6	AL1 + AL2 + MRB + AUTO RESET(1a1b contact)	
C	C	Counter
S	CS2	Charge switch communication
B	B	On/Off Button lock
M	MI	Mechanical interlock
D	DI or MOC	Door Interlock or MOC (Mechanism operated cell switch)
K	K1	Key Lock
K2	K2	Key Interlock Set
K3	K3	Key Lock Double
R	RCS	Ready to Close switch
T	TM	Temperature Monitoring
H1	SHT2	AC/DC 100~130V
H2	SHT2	AC/DC 200~250V
H3	SHT2	DC 125V
H4	SHT2	DC 24~30V
H5	SHT2	DC 48~60V
H6	SHT2	AC 380~480V
H7	SHT2	AC 48V





Note 1)

Note 1) It is a double shunt coil and not applicable when using UVT

# Model selecting guide

## Metasol ACB model numbering (Product selection)

### Body and accessories

Type	Ampere* Frame	Frame sizes & phase array	No. of pole	Rated current** (CT Spec.)	Connections
<b>AS</b>	<b>10</b>	<b>D</b>	<b>3</b>	<b>10</b>	<b>J</b>
<b>Metasol ACB</b>	06 630AF	D 630~2000AF	3 3P(D)	00 Without OCR & CT	Draw-out type
AN Standard type	08 800AF	D 3P/4P	4 4P(D, W)	02 200A	J Manual connection
AS High breaking type	10 1000AF	Standard ABC (N)		04 400A	A Automatic connection
<b>DN / DS</b>	13 1250AF	W 630~2000AF 4P		06 630A	Fixed type
Switch Disconnector	16 1600AF	Inverse type (N) ABC		08 800A	H Horizontal type
	20 2000AF			10 1000A	V Vertical type
				13 1250A	Mixed type
				16 1600A	M Horizontal
				20 2000A	Vertical
					Mixed type
					N Vertical
					Horizontal
					P Front type
	20 2000AF	E 2000 ~ 4000AF	3 3P (E)	00 Without OCR & CT	
	25 2500AF	3P/4P	4 4P (E, X)	02 200A	
	32 3200AF	Standard ABC (N)		04 400A	
	40 4000AF	X 2000 ~ 4000AF 4P		06 630A	
		Inverse type (N) ABC		08 800A	
				10 1000A	
				13 1250A	
				16 1600A	
				20 2000A	
				25 2500A	
				32 3200A	
				40 4000A	
	40 4000AF	F 4000/5000AF	3 3P (F)	00 Without OCR & CT	
	50 5000AF	3P/4P	4 4P (F, Y)	40 4000A	
		Standard ABC (N)		50 5000A	
		Y 4000/5000AF			
		4P			
		Reverse phase			
		type(N) ABC			
	40 4000AF	G 4000/5000/6300AF	3 3P (G)	00 Without OCR & CT	
	50 5000AF	3P/4P	4 4P (G, Z)	40 4000A	
	63 6300AF	Standard ABC (N)		50 5000A	
		Z 4000/5000/6300AF		63 6300A	
		4P			
		Reverse phase			
		type(N) ABC			

\* 2000AF only offers with vertical type mounting terminals(Busbar).

\* 4000AF only offers with vertical type mounting terminals(Busbar).

\* AN type : 630 ~ 1600AF, 2000 ~ 3200AF

AS type : 630 ~ 2000AF, 2000 ~ 4000AF, 4000 ~ 5000AF, 4000 ~ 6300AF

\*\*AN type is available up to rated current 1600A when 630~1600AF is selected and rated current is available up to 3200A when 2000 ~ 3200AF is selected.

Note 1) D Frame 2000AF and E Frame 4000AF are vertical type only. F and G Frames are not applicable to flat type and flat mix type.

2) For DN/DS models, only the rated current (CT Spec.) "00" is applied.

3) DN models can be selected up to 3200AF and DS models up to 4000AF.

M1		D1		D1		AX		SS1		U1		AL	
Motor rated voltage		Closing coil rated voltage		Shunt coil rated voltage		Aux.contact & charging types		STU		UVT coil rated voltage			
MA	Without Motor	D0	Without Closing coil	D0	Without Shunt coil	AX	Standard type OFF - Charge 3a3b	Refer to page 27		U0	Without UVT coil		
M1	AC/DC 100V ~ 130V	D1	AC/DC 100V ~ 130V	D1	AC/DC 100V ~ 130V	AC	Standard type ON - Charge 3a3b			U1	AC/DC 100V ~ 130V		
M2	AC/DC 200V ~ 250V	D2	AC/DC 200V ~ 250V	D2	AC/DC 200V ~ 250V	BX	Standard type OFF - Charge 5a5b			U2	AC/DC 200V ~ 250V		
M3	DC 125V	D3	DC 125V	D3	DC 125V	BC	Standard type ON - Charge 5a5b			U3	DC 125V		
M4	DC 24V ~ 30V	D4	DC 24V ~ 30V	D4	DC 24V ~ 30V	HX	High capacity OFF - Charge 5a5b			U4	DC 24V ~ 30V		
M5	DC 48V ~ 60V	D5	DC 48V ~ 60V	D5	DC 48V ~ 60V	HC	High capacity ON - Charge 5a5b			U5	DC 48V ~ 60V		
M6	AC 380V ~ 415V	D6	AC 380V ~ 480V	D6	AC 380V~480V	CC	Standard type ON - Charge 6a6b			U6	AC 380V ~ 480V		
M7	AC 440V ~ 480V	D7	AC 48V	D7	AC 48V	JC	High capacity ON - Charge 6a6b			U7	AC 48V		
M8	AC 48V					GX	High capacity OFF - Charge 3a3b			* UVT Delay module is available over AC / DC 48V			
						GC	High capacity ON - Charge 3a3b						
						TX	TCS OFF - Charge 4a4b						
						TC	TCS ON - Charge 5a5b						

Option		
Symbol	Model	Option description
AL	AL1 + MRB	
A1	AL1 + MRB + RES(AC110~130V) *AC only	
A2	AL1 + AL2 + MRB	
A3	AL1 + MRB + RES(AC/DC 110~125V) *DC only	
A4	AL1 + MRB + RES(AC/DC 200~250V) *AC only	
A5	AL1 + MRB + AUTO RESET	
A6	AL1 + AL2 + MRB + AUTO RESET	
A7	AL1 + MRB + RES(AC/DC 110~125V) + AUTO RESET *DC only	
A8	AL1 + MRB + RES(AC/DC 200~250V) + AUTO RESET *AC only	
A9	AL1 + MRB + RES(AC/DC 110~130V) + AUTO RESET *AC only	
Y2	AL1 + AL2 + MRB(2b contact)	
Y6	AL1 + AL2 + MRB + AUTO RESET(2b contact)	
Z2	AL1 + AL2 + MRB(1a1b contact)	
Z6	AL1 + AL2 + MRB + AUTO RESET(1a1b contact)	
C	C	Counter
S <sup>Note1)</sup>	CS2	Charge switch communication
B	B	On/Off Button lock
M <sup>Note2)</sup>	MI	Mechanical interlock
D	DI or MOC	Door Interlock or MOC (Mechanism operated cell switch)
K	K1	Key Lock
K2	K2	Key Interlock Set
K3	K3	Key Lock Double
R	RCS	Ready to Close switch
T <sup>Note3)</sup>	TM	Temperature Monitoring
H1	SHT2	AC/DC 100 ~ 130V
H2	SHT2	AC/DC 200 ~ 250V
H3	SHT2	DC 125V
H4	SHT2	DC 24 ~ 30V
H5	SHT2	DC 48 ~ 60V
H6	SHT2	AC 380 ~ 480V
H7	SHT2	AC 48V

Note4)

Note 1), 2), 3) AN Type not applicable

4) Double shunt coil, not applicable when using UVT

# Model selecting guide

## Susol UL ACB model numbering

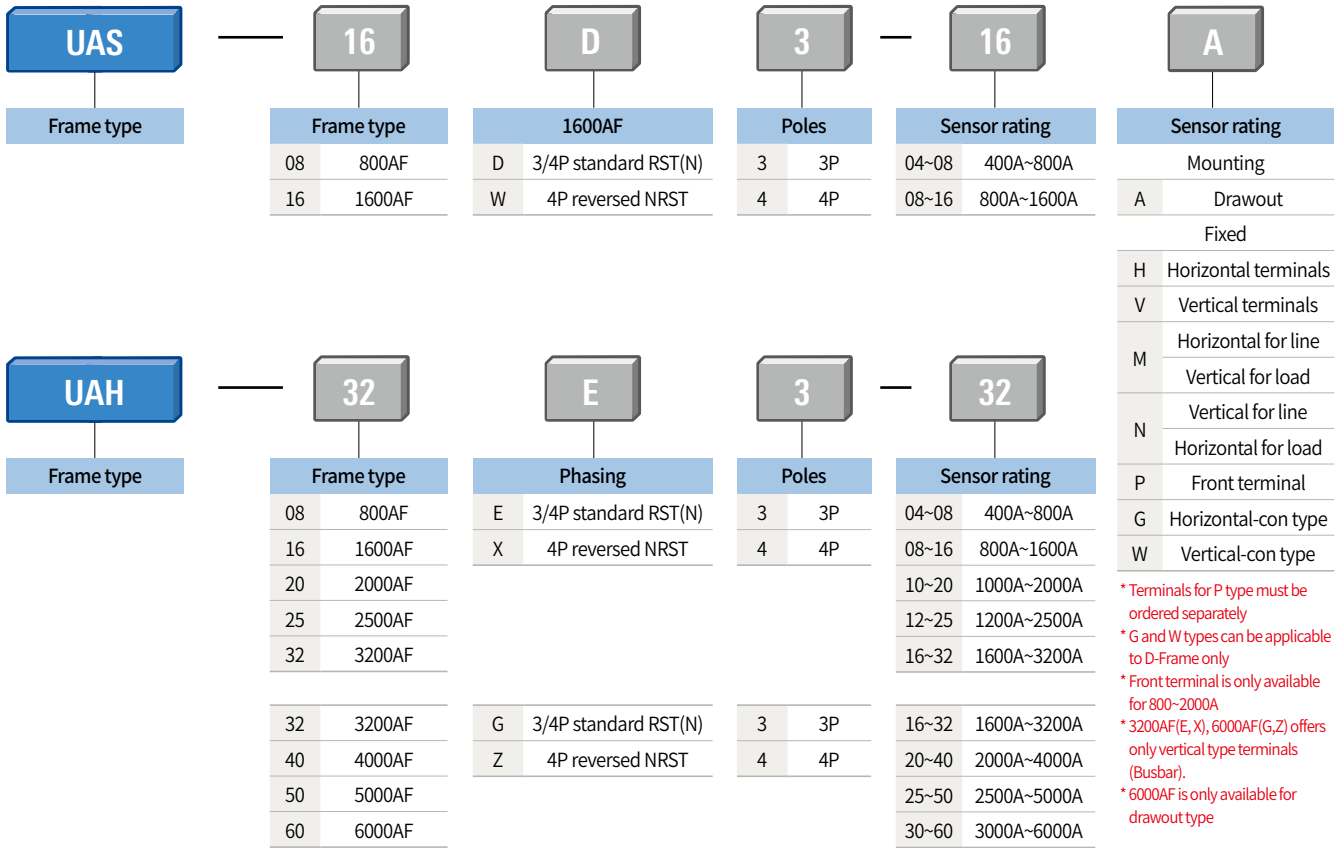

\* Terminals for P type must be ordered separately  
 \* G and W types can be applicable to D-Frame only  
 \* Front terminal is only available for 800~2000A  
 \* 3200AF(E, X), 6000AF(G,Z) offers only vertical type terminals (Busbar).  
 \* 6000AF is only available for drawout type

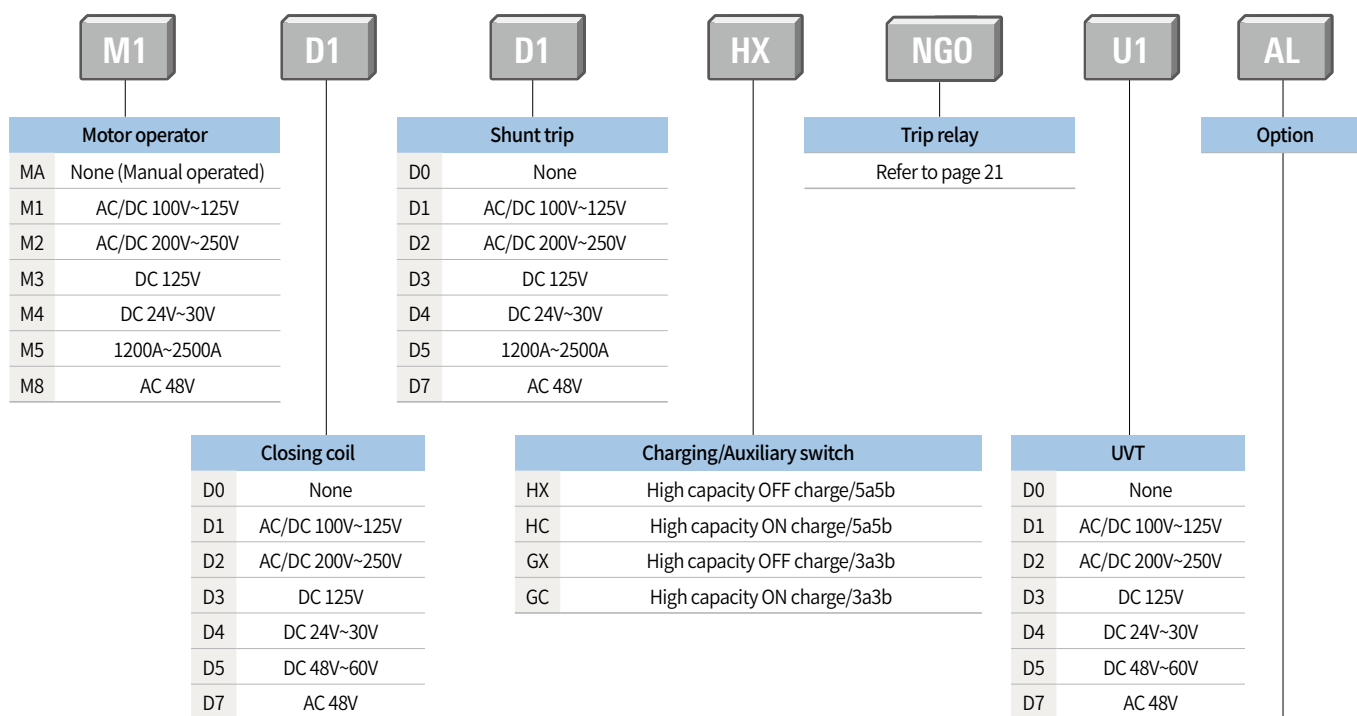

Code	Description	Code	Description	
AL	AL1+MRB	K	K1 Key lock	
A1	AL1+MRB +RES (AC110~130V) *AC only	K2	K2 Key Interlock set	
A2	AL1+AL2 +MRB	K3	K3 Key Interlock double	
A3	AL1+MRB +RES (DC110~125V) *DC only	K5	K5 Profalux lock (CAMLOCK type)	
A4	AL1+MRB +RES (AC200~250V) *AC only	K6	K6 Kirkkey lock (CAMLOCK type)	
A5	AL1+MRB +Auto reset	K7	K7 Kirkkey lock (CN22 type)	
A6	AL1+AL2 +MRB +Auto reset	R	RCS Ready to close switch	
A7	AL1+MRB +RES (DC110~125V) +Auto reset *DC only	T	TM Temperature monitoring	
A8	AL1+MRB +RES (AC200~250V) +Auto reset *AC only	H1	SHT2 Note 2) AC/DC 100V ~125V, Double shunt coil	
A9	AL1+MRB +RES (AC110~130V) +Auto reset *AC only	H2		AC/DC 200V ~250V, Double shunt coil
S	CS2 Charge switch communication	H3		DC 125V, Double shunt coil
B	B Lockable On/Off button cover	H4		DC 24V ~30V, Double shunt coil
M	MI Mechanical interlock	H5		DC 48V ~60V, Double shunt coil
D	DI or MOC Door interlock or MOC (Mechanism operated cell switch)	H7		AC 48V, Double shunt coil

N01	A4 (AL1+MRB +RES(AC200~250V))+B(Lockable On/Off button cover)+K(Key lock)+R(Ready to close switch)+M(Mechanic interlock)+E(Spring auto release)
N02	AL (AL1+MRB)+K(Key lock(OFF lock))+R(Ready to close switch)+D(Door interlock or MOC)+H1(AC/DC 100V ~ 130V, Double shunt coil)+E(Spring auto release)
N03	B(Lockable On/Off button cover)+K2(Key interlock set)+R(Ready to close switch)+T(Temperature monitoring)
N04	A4(AL1+MRB+RES(AC200~250V))+B(Lockable On/Off button cover)+K(Key lock(OFF lock))+M(Mechanical interlock)+T(Temperature monitoring)
N05	A1(AL1+MRB+RES110~130V)+B(Lockable On/Off button cover)+K(Key lock(OFF lock))+R(Ready to close switch)+M(Mechanical interlock)+T(Temperature monitoring)
N06	A2(AL1+AL2+MRB)+K(Key lock(OFF lock))+R(Ready to close switch)+T(Temperature monitoring)

Note) 1. \* Codes for over 5 optional accessories are composed separately  
 2. UVT and SHT2 can not be selected together. Select one of two.  
 3. C(counter) is provided as standard.

# Model selecting guide

## Susol ACB Cradle model numbering (Product selection)

### Cradle

<b>AL</b>	<b>H16D</b>	<b>3</b>	<b>A</b>	<b>H</b>	<b>E</b>	<b>S</b>																																				
Type	Rated current and frame	No. of pole	Terminal connections	Connections	Safety shutter	Arc cover (Zero Arc Space) <small>(note)</small>																																				
LS ACB Cradle	<table border="1"> <tr><td>H06~16D</td><td>AH - 06 ~ 16D</td></tr> <tr><td>H20D</td><td>AH - 20D</td></tr> <tr><td>H06~32E</td><td>AH - 06 ~ 32E</td></tr> <tr><td>H40E</td><td>AH - 40E</td></tr> <tr><td>H40~50G</td><td>AH - 40 ~ 50G</td></tr> <tr><td>H63G</td><td>AH - 63G</td></tr> </table>	H06~16D	AH - 06 ~ 16D	H20D	AH - 20D	H06~32E	AH - 06 ~ 32E	H40E	AH - 40E	H40~50G	AH - 40 ~ 50G	H63G	AH - 63G	<table border="1"> <tr><td>3</td><td>3P</td></tr> <tr><td>4</td><td>4P</td></tr> </table>	3	3P	4	4P	<table border="1"> <tr><td>A</td><td>Automatic connection</td></tr> <tr><td>J</td><td>Manual connection</td></tr> </table>	A	Automatic connection	J	Manual connection	<table border="1"> <tr><td>H</td><td>Horizontal type (H20D inapplicable)</td></tr> <tr><td>V</td><td>Vertical type</td></tr> <tr><td>M</td><td>Mixed type Line: Horizontal Load: Vertical (H20D inapplicable)</td></tr> <tr><td>N</td><td>Mixed type Line: Vertical Load: Horizontal (H20D inapplicable)</td></tr> <tr><td>P</td><td>Front type (20D, 40E, 50FG, 63G inapplicable)</td></tr> </table>	H	Horizontal type (H20D inapplicable)	V	Vertical type	M	Mixed type Line: Horizontal Load: Vertical (H20D inapplicable)	N	Mixed type Line: Vertical Load: Horizontal (H20D inapplicable)	P	Front type (20D, 40E, 50FG, 63G inapplicable)	<table border="1"> <tr><td>E</td><td>Without safety shutter</td></tr> <tr><td>F</td><td>With safety shutter</td></tr> </table>	E	Without safety shutter	F	With safety shutter	<table border="1"> <tr><td>S</td><td>With ARC Cover</td></tr> </table>	S	With ARC Cover
H06~16D	AH - 06 ~ 16D																																									
H20D	AH - 20D																																									
H06~32E	AH - 06 ~ 32E																																									
H40E	AH - 40E																																									
H40~50G	AH - 40 ~ 50G																																									
H63G	AH - 63G																																									
3	3P																																									
4	4P																																									
A	Automatic connection																																									
J	Manual connection																																									
H	Horizontal type (H20D inapplicable)																																									
V	Vertical type																																									
M	Mixed type Line: Horizontal Load: Vertical (H20D inapplicable)																																									
N	Mixed type Line: Vertical Load: Horizontal (H20D inapplicable)																																									
P	Front type (20D, 40E, 50FG, 63G inapplicable)																																									
E	Without safety shutter																																									
F	With safety shutter																																									
S	With ARC Cover																																									

\*D Frame 2000AF and E Frame 4000AF are vertical type only.



Note) Susol ACB is supplied as an arc cover standard.

## Metasol ACB Cradle model numbering (Product selection)

### Cradle

<b>AL</b>	<b>N16D</b>	<b>3</b>	<b>J</b>	<b>H</b>	<b>E</b>	<b>N</b>																																																
Type	Rated current and frame	No. of pole	Terminal connections	Connections	Safety shutter	Arc cover (Zero Arc Space)																																																
Metasol ACB Cradle	<table border="1"> <tr><td>N06~16D</td><td>AN - 06 ~ 16D</td></tr> <tr><td>S06~16D</td><td>AS - 06 ~ 16D</td></tr> <tr><td>S20D</td><td>AS - 20D</td></tr> <tr><td>N20~25E</td><td>AN - 20 ~ 25E</td></tr> <tr><td>N32E</td><td>AN - 32E</td></tr> <tr><td>S20~25E</td><td>AS - 20 ~ 25E</td></tr> <tr><td>S32E</td><td>AS - 32E</td></tr> <tr><td>S40E</td><td>AS - 40E</td></tr> <tr><td>S40~50F</td><td>AS - 40 ~ 50F</td></tr> <tr><td>S40~50G</td><td>AS - 40 ~ 50G</td></tr> <tr><td>S63G</td><td>AS - 63G</td></tr> </table>	N06~16D	AN - 06 ~ 16D	S06~16D	AS - 06 ~ 16D	S20D	AS - 20D	N20~25E	AN - 20 ~ 25E	N32E	AN - 32E	S20~25E	AS - 20 ~ 25E	S32E	AS - 32E	S40E	AS - 40E	S40~50F	AS - 40 ~ 50F	S40~50G	AS - 40 ~ 50G	S63G	AS - 63G	<table border="1"> <tr><td>3</td><td>3P</td></tr> <tr><td>4</td><td>4P</td></tr> </table>	3	3P	4	4P	<table border="1"> <tr><td>J</td><td>Without manual access</td></tr> <tr><td>A</td><td>With automatic connection</td></tr> </table>	J	Without manual access	A	With automatic connection	<table border="1"> <tr><td>H</td><td>Horizontal type (20D inapplicable)</td></tr> <tr><td>V</td><td>Vertical type</td></tr> <tr><td>M</td><td>Mixed type Line: Horizontal Load: Vertical (20D inapplicable)</td></tr> <tr><td>N</td><td>Mixed type Line: Vertical Load: Horizontal (20D inapplicable)</td></tr> <tr><td>P</td><td>Front type (20D, 40E, 50FG, 63G inapplicable)</td></tr> </table>	H	Horizontal type (20D inapplicable)	V	Vertical type	M	Mixed type Line: Horizontal Load: Vertical (20D inapplicable)	N	Mixed type Line: Vertical Load: Horizontal (20D inapplicable)	P	Front type (20D, 40E, 50FG, 63G inapplicable)	<table border="1"> <tr><td>E</td><td>Without safety shutter</td></tr> <tr><td>F</td><td>With safety shutter</td></tr> </table>	E	Without safety shutter	F	With safety shutter	<table border="1"> <tr><td>N</td><td>Without ARC Cover</td></tr> <tr><td>S</td><td>With ARC Cover</td></tr> </table>	N	Without ARC Cover	S	With ARC Cover
N06~16D	AN - 06 ~ 16D																																																					
S06~16D	AS - 06 ~ 16D																																																					
S20D	AS - 20D																																																					
N20~25E	AN - 20 ~ 25E																																																					
N32E	AN - 32E																																																					
S20~25E	AS - 20 ~ 25E																																																					
S32E	AS - 32E																																																					
S40E	AS - 40E																																																					
S40~50F	AS - 40 ~ 50F																																																					
S40~50G	AS - 40 ~ 50G																																																					
S63G	AS - 63G																																																					
3	3P																																																					
4	4P																																																					
J	Without manual access																																																					
A	With automatic connection																																																					
H	Horizontal type (20D inapplicable)																																																					
V	Vertical type																																																					
M	Mixed type Line: Horizontal Load: Vertical (20D inapplicable)																																																					
N	Mixed type Line: Vertical Load: Horizontal (20D inapplicable)																																																					
P	Front type (20D, 40E, 50FG, 63G inapplicable)																																																					
E	Without safety shutter																																																					
F	With safety shutter																																																					
N	Without ARC Cover																																																					
S	With ARC Cover																																																					

\*D Frame 2000AF and E Frame 4000AF are vertical type only.

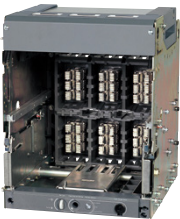

## Susol UL ACB Cradle model numbering

### Cradle

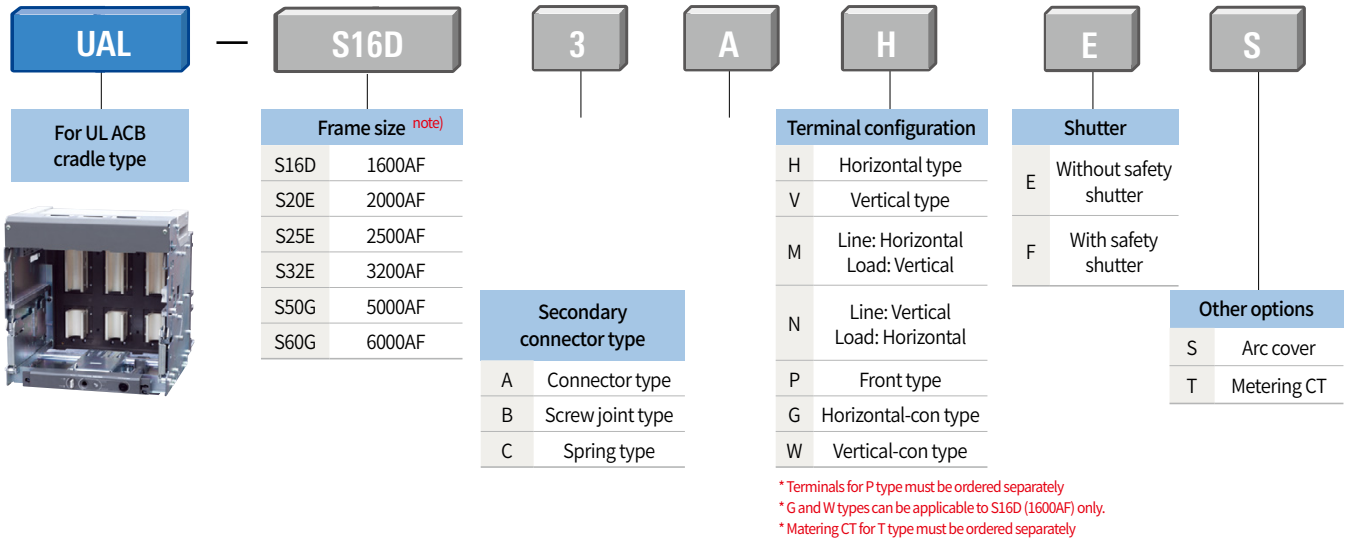

Note) The corresponding Breaker Adapter

Breaker		Adapter
UAS-08D	UAS-08W	S16D
UAS-16D	UAS-16W	
UAH-08E	UAH-08X	S20E
UAH-16E	UAH-16X	
UAH-20E	UAH-20X	
UAH-25E	UAH-25X	S25E
UAH-32E	UAH-32X	S32E
UAH-32G	UAH-32Z	S50G
UAH-40G	UAH-40Z	
UAH-50G	UAH-50Z	
UAH-60G	UAH-60Z	S60G

# Smart trip unit

## Smart Trip Unit model numbering (Product selection)

### N type



N		H		G	
Trip unit type		Communication & Leakage Detection		Control Power & Frequency	
0	N/A	0	N/A	0	N/A
N		H		G	
Trip unit type		Relay Function / Commutation Fuction(Default)		Frequency (Main Circuit)	Control Power Voltage
N	Normal	H	L,S,I,G + NFC	0	60Hz No Control Power
				5	50Hz No Control Power

\* Self-power is Default  
\* No Output Contact  
(Accident indication can be confirmed only by LED)

### A type



A		G		0	
Trip unit type		Relay Function / Commutation Fuction		Frequency (Main Circuit)	Control Power Voltage
A	Ammeter	H	L,S,I,G	0	60Hz No Control Power
		D	L,S,I,G / Communication	1	60Hz AC/DC 100V~250V
		J	L,S,I,Gext + ZCT / Communication	2	60Hz DC 24V~48V
		Y	L,S,I,Gext + Ground wire CT / Communication	5	50Hz No Control Power
		B	L,S,I,G + PTA / Communication	6	50Hz AC/DC 100V~250V
		O	L,S,I,G + Neutral CT / Communication	7	50Hz DC 24V~48V
		V	L,S,I,G + PTA (For Marine)		

\* Self-power is Default  
\* Only AH Type can select "0, 5" (AH0, AH5)  
\* No Output Contact when choosing "0"  
(Accident indication can be confirmed only by LED)  
\* AV Type has no LCD Screen

### P type



P		S		1		
Trip unit type		Relay Function / Commutation Fuction(Default)		Frequency (Main Circuit)	Control Power Voltage	Communication
P	Power meter	S	L,S,I,G + PTA	1	60Hz AC/DC 100V~250V	N/A
		J	L,S,I,Gext + ZCT	2	60Hz DC 24V~48V	N/A
		Y	L,S,I,Gext + Ground wire CT	6	50Hz AC/DC 100V~250V	N/A
		O	L,S,I,G + Neutral CT	7	50Hz DC 24V~48V	N/A
				3	60Hz AC/DC 100V~250V	Bluetooth
				4	60Hz DC 24V~48V	Bluetooth
				8	50Hz AC/DC 100V~250V	Bluetooth
				9	50Hz DC 24V~48V	Bluetooth

### S type



S		S		1		
Trip unit type		Relay Function / Commutation Fuction(Default)		Frequency (Main Circuit)	Control Power Voltage	Communication
S	Supreme meter	S	L,S,I,G + PTA	1	60Hz AC/DC 100V~250V	Bluetooth/NFC
		J	L,S,I,Gext + ZCT	2	60Hz DC 24V~48V	Bluetooth/NFC
		Y	L,S,I,Gext + Ground wire CT	6	50Hz AC/DC 100V~250V	Bluetooth/NFC
		O	L,S,I,G + Neutral CT	7	50Hz DC 24V~48V	Bluetooth/NFC

\* Self-power is Default (Automatic power supply to the Trip Unit without additional control power)  
\* L,S,I: Long time delay trip, Short time delay trip, Instantaneous trip \* G: Ground fault (Residual earth fault protection)  
\* Gext + ZCT: Earth leakage protection (Earth Fault Current: 0.5A ~ 30A) - Only suitable for under 1600A products and cables  
\* Gext + Ground wire CT: Source return Type \* PTA: Pre-trip alarm Function  
\* Customers purchase their own Ground wire CT (Secondary output: 5A, accuracy 1%)  
\* Customers purchase their own Neutral CT (Primary output: same as ACB's Rated Current / Secondary output: 5A, accuracy 1%) \* The STU acceptable voltage range is 100 to 250V.

Item	Description	Features	Remark
72313460708	TOTAL ASS'Y, VDM(Shield Cable), EXTERNAL, STU	Accessory	Separate purchasing

\* If you want to apply external VDM separately, please order the code above.





# Rated specifications



## Susol ACB

Frame			AH - D										
Type			AH - 06D	AH - 08D	AH - 10D	AH - 13D	AH - 16D	AH - 20D					
Ampere frame	(AF)		630	800	1000	1250	1600	2000					
Rated current (In max)	(A)		200	400	630	630	800	1000					
			400	630	800	1000	1250	1600					
			630	800	1000	1250	1600	2000					
Rated operational voltage (Ue)	(V)		690										
Rated insulation voltage (Ui)	(V)		1000										
Frequency	(Hz)		50/60										
Number of poles	(P)		3/4										
Setting current *	(A)	Control trip relay (... × In max)	0.4 ~ 1.0										
N pole rated current	(A)		630	800	1000	1250	1600	2000					
Rated breaking current (Icu) (Sym)	(kA)	IEC 60947-2 KSC 4620	AC	690V / 600V / 550V ***		65							
				500V / 480V / 460V		85							
				415V / 380V / 230V / 220V		85							
Rated service breaking capacity (Ics)	(kA)			...% × Icu		100							
Rated input current (Icm) (peak)	(kA)	IEC 60947-2 KSC 4620	AC	690V / 600V / 550V ***		143							
				500V / 480V / 460V		187							
				415V / 380V / 230V / 220V		187							
Rated short-time current (Icw)	(kA)			1 second		65							
				2 seconds		60							
				3 seconds		50							
Rated impulse withstand voltage (Uimp)	(kV)			12									
Operating time (t)	(ms)			Total cut-off time, maximum		Less than 25ms under Icw / Less than 75ms over Icw							
				Input time		Less than 80							
Life cycle	ACB	(time)	Mechanical		20000								
			Electrical		5000								
Weight (3P/4P)	(kg)	Draw-out type	Body + cradle	Electric charging method		63/74		70/85					
				Manual charging method		61/72		68/83					
		Cradle				29/32		33/40					
		Fixed type				34/44		38/47					
Connections **			Fixed type/ Draw-out type	Horizontal type		●	●	●	●	●	—		
				Vertical type		○	○	○	○	○	○	●	
				Flat surface type		○	○	○	○	○	○	○	—
				Mix type		○	○	○	○	○	○	○	—
External dimensions	Withdrawal type	(mm)	H : 430 (460), D : 375	W (3P/4P)		334/419							
	Stationary type	(mm)	H : 300, D : 295	W (3P/4P)		300/385							
Certificate & Approval			KS / KEMA / KERI / GOST / CCC										
Certificate & Approval			LR, ABS, DNV, KR, BV, GL, RINA, NK										

\*Refer to detailed STU rating      \*\*● : Standard ○ : Option

\*\*\*Acquired KSC 4620 rated voltage is 690/600V, and low rated use voltage is KS certified with 600V breaking capacity (Reason: Refer to the classification of KSC 4620 audit criteria certification)

※ Life time is the lifespan, not the warranty life, and is charged for maintenance. If an abnormality occurs in the accessory device during use, it can be replaced and used.

Quality Assurance : Based on IEC60947-2 number of opening and closing times within the warranty period

※ D Frame 2000AF and E Frame 4000AF are available in vertical type only.



AH - E										AH - G		
AH - 06E	AH - 08E	AH - 10E	AH - 13E	AH - 16E	AH - 20E	AH - 25E	AH - 32E	AH - 40E		AH - 40G	AH - 50G	AH - 63G
630	800	1000	1250	1600	2000	2500	3200	4000		4000	5000	6300
200	400	630	630	800	1000	1250	1600	2000		2000	2500	3200
400	630	800	800	1000	1250	1600	2000	2500		2500	3200	4000
630	800	1000	1000	1250	1600	2000	2500	3200		3200	4000	5000
			1250	1600	2000	2500	3200	4000		4000	5000	6300
690										690		
1000										1000		
50/60										50/60		
3/4										3/4		
0.4 ~ 1.0										0.4 ~ 1.0		
630	800	1000	1250	1600	2000	2500	3200	4000		4000	5000	6300
85										100		
100										150		
100										150		
100										100		
187										220		
220										330		
220										330		
85										100		
75										85		
65										75		
12										12		
Less than 25ms under Icw / Less than 75ms over Icw										Less than 25ms under Icw / Less than 75ms over Icw		
Less than 80										Less than 90		
15000										10000		
5000										2000		
87/103							107/139			181/223		186/230
85/101							102/145			179/221		184/228
44/55							65/85			97/117		102/124
44/55							61/81			98/123		103/130
42/53							60/80			96/121		101/128
●	●	●	●	●	●	●	●	—		○	○	○
○	○	○	○	○	○	○	○	●		●	●	●
○	○	○	○	○	○	○	○	—		—	—	—
○	○	○	○	○	○	○	○	—		—	—	—
412/527										785/1015		
378/493										751/981		
KS / KEMA / KERI / GOST / KEPIC / CCC										KS / KEMA / KERI / GOST / CCC		
LR, ABS, DNV, KR, BV, GL, RINA, NK										LR, ABS, DNV, KR, BV, GL, RINA, NK		

※ Although reverse connection to the power supply and load side is possible, use it as a normal connection for maintenance, inspection, and safety.

※ The neutral pole of the 4-pole type is broke by pre-input.

※ Rated current brackets are rated for ACB for nuclear power plants.

1) Test specifications : KEPIC EED 1200/END 1100 / END 2000

2) Nuclear power plant electrical class : Class 1E, Quality class : Q

3) Rated : AC 508V, 100KA, 800/16 00/2000/3200A

# Rated specifications



## Metasol ACB

Frame		AN - D				
Type		AN - 06D	AN - 08D	AN - 10D	AN - 13D	AN - 16D
Ampere frame	(AF)	630	800	1000	1250	1600
Rated current (I <sub>n</sub> max)	(A)	200	400	630	630	800
		400	630	800	800	1000
		630	800	1000	1000	1250
Rated operational voltage (U <sub>e</sub> )	(V)	690				
Rated insulation voltage (U <sub>i</sub> )	(V)	1000				
Frequency	(Hz)	50/60				
Number of poles	(P)	3/4				
Setting current *	(A)	Control trip relay (... × I <sub>n</sub> max)				
		0.4 ~ 1.0				
N pole rated current	(A)	630	800	1000	1250	1600
Rated breaking current (I <sub>cu</sub> ) (Sym)	(kA)	IEC 60947-2 KS C 4620	AC	690V / 600V / 550V ***		50
				500V / 480V / 460V		65
				415V / 380V / 230V / 220V		65
Rated service breaking capacity (I <sub>cs</sub> )	(kA)	...% × I <sub>cu</sub>		100		
Rated input current (I <sub>cm</sub> ) (peak)	(kA)	IEC 60947-2 KS C 4620	AC	690V / 600V / 550V ***		105
				500V / 480V / 460V		143
				415V / 380V / 230V / 220V		143
Rated short-time current (I <sub>cw</sub> )	(kA)	1 second		50		
		2 seconds		42		
		3 seconds		36		
Rated impulse withstand voltage (U <sub>imp</sub> )	(kV)	12				
Operating time (t)	(ms)	Total cut-off time, maximum		Less than 25ms under I <sub>cw</sub> / Less than 75ms over I <sub>cw</sub>		
		Input time		Less than 80		
Life cycle	ACB	(time)	Mechanical		20000	
			Electrical		5000	
Weight (3P/4P)	(kg)	Draw-out type	Body + cradle	Electric charging method	63/74	
				Manual charging method	61/72	
		Fixed type	Cradle	Electric charging method	29/32	
				Manual charging method	34/44	
Connections **			Fixed type/ Draw-out type	Horizontal type	●	●
				Vertical type	○	○
				Flat surface type	○	○
				Mix type	○	○
External dimensions	Draw-out type	(mm)	H : 430 (460), D : 375	W (3P/4P)	334/419	
	Fixed type	(mm)	H : 300, D : 295	W (3P/4P)	300/385	
Certificate & Approval		KEMA / KERI / KS / GOST				
Marine classification		—				

\*Refer to detailed STU rating      \*\*●: Standard ○: Option

\*\*\*Acquired KSC 4620 rated voltage is 690/600V, and low rated use voltage is KS certified with 600V breaking capacity (Reason: Refer to the classification of KSC 4620 audit criteria certification)

※ Life time is the lifespan, not the warranty life, and is charged for maintenance. If an abnormality occurs in the accessory device during use, it can be replaced and used.

Quality Assurance : Based on IEC60947-2 number of opening and closing times within the warranty period

※ D Frame 2000AF and E Frame 4000AF are available in vertical type only.



AS - D						AS - E					AS - F		AS - G		
AS - 06D	AS - 08D	AS - 10D	AS - 13D	AS - 16D	AS - 20D	AS - 20E	AS - 25E	AS - 32E	AS - 40E	AS - 40F	AS - 50F	AS - 40G	AS - 50G	AS - 63G	
630	800	1000	1250	1600	2000	2000	2500	3200	4000	4000	5000	4000	5000	6300	
200	400	630	630	800	1000	200, 400,	1250	1600	2000	2000	2500	2000	2500	3200	
400	630	800	800	1000	1250	630, 800,	1600	2000	2500	2500	3200	2500	3200	4000	
630	800	1000	1000	1250	1600	1000, 1250,	2000	2500	3200	3200	4000	3200	4000	5000	
			1250	1600	2000	1600, 2000	2500	3200	4000	4000	5000	4000	5000	6300	
690						690					690		690		
1000						1000					1000		1000		
50/60						50/60					50/60		50/60		
3/4						3/4					3/4		3/4		
0.4 ~ 1.0						0.4 ~ 1.0					0.4 ~ 1.0		0.4 ~ 1.0		
630	800	1000	1250	1600	2000	630, 800, 1000, 1250, 1600, 2000	2500	3200	4000	4000	5000	4000	5000	6300	
65						85					85		100		
70						85					100		120		
70						85					100		120		
100						100					100		100		
143						187					187		220		
154						187					220		264		
154						187					220		264		
65						85					85		100		
50						75					75		85		
42						65					65		75		
12						12					12		12		
Less than 25ms under I <sub>cw</sub> / Less than 75ms over I <sub>cw</sub>															
Less than 80						Less than 80					Less than 90		Less than 90		
20000						15000					10000		10000		
5000						5000					2000		2000		
63/74					70/85	87/103			107/139	145/173		181/223		186/230	
61/72					63/83	85/101			102/145	143/171		179/221		184/228	
29/32					33/40	44/50			65/85	78/90		97/117		102/124	
34/44					38/47	44/55			61/81	76/94		98/123		103/130	
32/42					36/45	42/53			60/80	74/92		96/121		101/128	
●	●	●	●	●	—	●	●	●	—	○	○	○	○	○	
○	○	○	○	○	●	○	○	○	●	●	●	●	●	○	
○	○	○	○	○	—	○	○	○	—	—	—	—	—	—	
○	○	○	○	○	—	○	○	○	—	—	—	—	—	—	
334/419						412/527					629/799		785/1015		
300/385						378/493					597/767		751/981		
KEMA / KERI / KS / GOST						KEMA / KERI / KS / GOST					KEMA / KERI / KS / GOST / KEPIC				
LR, ABS, DNV, KR, BV, GL, RINA, NK						LR, ABS, DNV, KR, BV, GL, RINA, NK					LR, ABS, DNV, KR, BV, GL, RINA, NK				

※ Although reverse connection to the power supply and load side is possible, use it as a normal connection for maintenance, inspection, and safety.

※ The neutral pole of the 4-pole type is broke by pre-input.

※ Rated current brackets are rated for ACB for nuclear power plants.

1) Test specifications: KEPIC EED 1200/END 1100/END 2000

2) Nuclear power plant electrical class: Class 1E, Quality class: Q

3) Rated: AC 508V, 100KA, 3200/4000A

# Rated specifications



## Susol UL ACB

Type				Susol UAS-□□D		
AF				08	16	
Rated current (In max)	(A)	at 40°C		800	1600	
Rated current	(A)	at 40°C		400	800	
				6000	1000	
				630	1250	
				800	1600	
Rated maximum voltage	(V)			254V / 508V / 635V		
Frequency	(Hz)			50 / 60		
Number of poles	(P)			3P / 4P		
Type of trip relay (Electronic trip device)				N, A, P, S (4 type)		
Rated short circuit current 635V (Sym.) UL 1066 ANSI C37.13	(kA)	With instantaneous	AC	635V	65	
				508V	85	
				254V	85	
		Without* instantaneous	AC	635V	65	
				508V	65	
				254V	65	
Rated short time current	(kA)			65		
Operating time (t)	(ms)	Maximum total breaking time		Less than 25ms under I <sub>cw</sub> / Less than 75ms over I <sub>cw</sub>		
		Maximum closing time		80ms under		
Life cycle ACB	(time)	Mechanical	Without maintenance		12,500	
			With maintenance		-	
		Electrical	Without maintenance		2,800	
			With maintenance		-	
Weight	lb (kg)	Drawout type	3P		154 (70)	
			4P		187 (85)	
			3P		71 (32)	
			4P		84 (38)	
		Fixed type	3P		77 (35)	
			4P		99 (45)	
External dimension	Draw-out type	in (mm)	H×W×D	3P		16.93×13.15×16.02 (430×334×407)
				4P		16.93×16.5×16.02 (430×419×407)
		in (mm)	H×W×D	3P		11.81×11.81×11.61 (300×300×295)
				4P		11.81×15.16×11.61 (300×385×295)
Enclosure dimension	in (mm)	H×W×D	3P		19.69×15.75×13.39 (500×400×340)	
			4P		19.69×19.69×13.39 (500×500×340)	

Note: \* shows the breaking capacity of the UAA type.



Susol UAS-□□E					Susol UAS-□□G				
08	16	20	25	32	32	40	50	60	
800	1600	2000	2500	3200	3200	4000	5000	6000	
400	800	1000	1200	1600	1600	2000	2500	3000	
600	1000	1200	1250	2000	2000	2500	3000	3200	
630	1200	1250	1600	2500	2500	3000	3200	3600	
800	1250	1600	2000	3000	3000	3200	3600	4000	
	1600	2000	2500	3200	3200	3600	4000	5000	
						4000	5000	6000	
254V / 508V / 635V					254V / 508V / 635V				
50 / 60					50 / 60				
3P / 4P					3P / 4P				
N, A, P, S (4 type)					N, A, P, S (4 type)				
85					100				
100					130				
100					130				
85					100				
85					100				
85					100				
85					100				
Less than 25ms under Icw/Less than 75ms over Icw					Less than 25ms under Icw/Less than 75ms over Icw				
80ms under					90ms under				
12,500				12,500	10,000				
-				-	-				
2,800				1,000	1,000				
-				-	-				
214 (97)		245 (111)		326 (148)	489 (222)		709 (321)		
269 (122)		309 (140)		414 (188)	626 (284)		919 (417)		
99 (45)		123 (56)		205 (93)	276 (125)		482 (218)		
121 (55)		152 (69)		256 (116)	355 (161)		630 (286)		
101 (46)		110 (50)		196 (89)	227 (103)		433 (196)		
126 (57)		137 (62)		249 (113)	287 (130)		561 (255)		
16.93×16.22×16.02 (430×412×407)					18.11×30.91×16.02 (460×785×407)				
16.93×20.75×16.02 (430×527×407)					18.11×39.96×16.02 (460×1015×407)				
11.81×14.88×11.61 (300×378×295)					11.81×29.57×11.61 (300×751×295)				
11.81×19.41×11.61 (300×493×295)					11.81×38.62×11.61 (300×981×295)				
19.69×19.69×13.39 (500×500×340)					31.5×32.48×13.39 (800×825×340)				
19.69×24.21×13.39 (500×615×340)					31.5×41.54×13.39 (800×1055×340)				

# Smart Trip Unit

## Advanced Trip Relay!

With the world's best measurement accuracy and increased relay elements, the relay operation stability is enhanced, and the abnormal self-diagnosis function prevents mis-trips and ensures the stability of abnormal conditions through alarms.

NFC and Bluetooth built-in and Smart add-on modules can be configured. Monitoring and monitoring is possible through service access anytime, anywhere by securing a Smart LV solution through ICT convergence technology.

## STU function-specific series



### N type

- Device operation through self-power
- Current relay function
- Supports USB communication



### A type

- Device operation through self-power
- Device operation via AC or DC
- Current relay function
- Segment LCD Display
- DO output
- Supports USB communication
- Supports RS485 communication



### P type

- Device operation through self-power
- Device operation via AC or DC
- Current/voltage/frequency/power relay function
- 3.5" Graphic Display
- DO output
- Supports USB communication
- Supports RS485 communication



### S type

- Device operation through self-power
- Device operation via AC or DC
- Current/voltage/frequency/power relay function
- 3.5" Graphic Display
- DO output
- Relay setting group A/B available
- Supports USB communication
- Supports RS485 communication
- NFC/BLE communication support





## Types of STU

	Type N	Type A	Type P	Type S
Exterior				
Current relay	• L (N), S, I, G, PTA	• L (N), S, I, G, PTA, Gext	• L (N), S, I, G, PTA, Gext • D, S (V), IU	• L (N), S1, S2, I, G, PTA, Gext • D, S (V) 1, S (V) 2
Voltage relay			• UV, OV, RV, VU	• UV1, UV2, OV1, OV2, RV, VU
Frequency relay			• UF, OF, ROCOF	• UF1, UF2, OF1, OF2, ROCOF
Power relay			• RP, RQ, OP, OQ, UP	• RP, RQ1, RQ2, OP, OQ, UP
Group control				• A, B (can be changed by communication)
Relay fine adjustment			• L, S, I Pickup current	
ERMS		• Control by DI and communication	• Control by DI and communication	• Control by DI and communication
IDMTL support	• Supports L relay element Thermal and DT, SIT, VIT, EIT, EIT50	• Supports L relay element Thermal and DT, SIT, VIT, EIT, EIT50	• Supports L relay element Thermal and DT, SIT, VIT, EIT, EIT50	• Supports L relay element Thermal and DT, SIT, VIT, EIT, EIT50
Trip information maintenance LED	• L, S, I, G/PTA, SP	• L, S, I, G/Gext/PTA, SP	• L, S, I, G/Gext/PTA, SP	• L, S, I, G/Gext/PTA, SP
Screen		• 32 accident events indicated [Accident phase/current/time]	• 127 accident events indicated [Accident phase/current/time]	• 127 accident events indicated [Accident phase/current/time]
Accident record Memory	• 127 accident events indicated [Accident phase/current/time]	• 127 accident events indicated • 6 accident events indicated [Does not support Self-power]	• 127 accident events indicated • 6 accident events indicated [Does not support Self-power]	• 127 accident events indicated • 6 accident events indicated [Does not support Self-power]

# Smart Trip Unit

## STU types and main functions

	Type N	Type A	Type P	Type S
<b>Measurement function</b>	<ul style="list-style-type: none"> <li>• Current [R/S/T/N]</li> <li>• Current phase (A phase current standard)</li> <li>• Vector sum image current</li> <li>• Normal and reverse phase current</li> <li>• Current imbalance rate</li> <li>• Current demand before each phase</li> </ul>	<ul style="list-style-type: none"> <li>• Current [R/S/T/N]</li> <li>• External CT current</li> <li>• Current phase (Based on phase A current)</li> <li>• Vector sum image current</li> <li>• Normal and reverse phase current</li> <li>• Current imbalance rate</li> <li>• Current demand before each phase</li> </ul>	<ul style="list-style-type: none"> <li>• 3-phase phase voltage, line voltage</li> <li>• Current [R/S/T/N]</li> <li>• Frequency</li> <li>• External CT current</li> <li>• Voltage/current phase (Based on phase A voltage)</li> <li>• Total/each phase power [P, Q, S]</li> <li>• Total/each power factor</li> <li>• Positive/reverse, effective/invalid/apparent energy</li> <li>• Vector Sum image voltage</li> <li>• Vector sum image current</li> <li>• Normal and reverse phase voltage</li> <li>• Normal and reverse phase current</li> <li>• Voltage unbalance rate</li> <li>• Current imbalance rate</li> <li>• Current demand before each phase</li> <li>• Demand on the last apparent, reactive, or active power</li> </ul>	<ul style="list-style-type: none"> <li>• 3-phase phase voltage, line voltage</li> <li>• Current [R/S/T/N]</li> <li>• Frequency</li> <li>• External CT current</li> <li>• Voltage/current phase (Based on phase A voltage)</li> <li>• Total/each phase power [P, Q, S]</li> <li>• Total/each power factor</li> <li>• Positive/reverse, effective/invalid/apparent energy</li> <li>• Vector Sum image voltage</li> <li>• Vector sum image current</li> <li>• Normal and reverse phase voltage</li> <li>• Normal and reverse phase current</li> <li>• Voltage unbalance rate</li> <li>• Current imbalance rate</li> <li>• Current demand before each phase</li> <li>• Demand on the last apparent, reactive, or active power</li> </ul>
<b>Measurement accuracy</b>	<b>Current</b>	0.5%	0.5%	0.5%
	<b>Voltage</b>			0.5%
	<b>Power</b>			class 1.0 (IEC 62053 - 21, 22)
	<b>Frequency</b>	50, 60 Hz device classification	50, 60 Hz device classification	0.1% (10 ~ 200Hz)
<b>PQ function</b>	<ul style="list-style-type: none"> <li>• 63<sup>rd</sup> harmonic current</li> <li>• Current THD, TDD, K-Factor</li> </ul>	<ul style="list-style-type: none"> <li>• 63<sup>rd</sup> harmonic current</li> <li>• Current THD, TDD, K-Factor</li> </ul>	<ul style="list-style-type: none"> <li>• 63<sup>rd</sup> harmonic current</li> <li>• Voltage THD</li> <li>• Current THD, TDD, K-Factor</li> </ul>	<ul style="list-style-type: none"> <li>• 63<sup>rd</sup> harmonic current</li> <li>• Voltage THD</li> <li>• Current THD, TDD, K-Factor</li> </ul>
<b>Measurement record</b>	<ul style="list-style-type: none"> <li>• Max Current demand</li> <li>• Max <math>I_o</math></li> <li>• Max <math>I_n</math></li> <li>• Max internal temperature</li> </ul>	<ul style="list-style-type: none"> <li>• Max Current demand</li> <li>• Max <math>I_o</math></li> <li>• Max Ext <math>I_o</math></li> <li>• Max <math>I_n</math></li> <li>• Max internal temperature</li> </ul>	<ul style="list-style-type: none"> <li>• Max Current demand</li> <li>• Max active/reactive/apparent power</li> <li>• Demand</li> <li>• Max active power</li> <li>• Max <math>V_o</math></li> <li>• Max <math>I_o</math></li> <li>• Max Ext <math>I_o</math></li> <li>• Max <math>I_n</math></li> <li>• Max internal temperature</li> </ul>	<ul style="list-style-type: none"> <li>• Max Current demand</li> <li>• Max active/reactive/apparent power</li> <li>• Demand</li> <li>• Max active power</li> <li>• Max <math>V_o</math></li> <li>• Max <math>I_o</math></li> <li>• Max Ext <math>I_o</math></li> <li>• Max <math>I_n</math></li> <li>• Max internal temperature</li> </ul>
<b>Real - time waveform</b>		<ul style="list-style-type: none"> <li>• Can be checked by communication</li> </ul>	<ul style="list-style-type: none"> <li>• Can be checked by communication</li> <li>• Can be checked on the LCD screen</li> </ul>	<ul style="list-style-type: none"> <li>• Can be checked by communication</li> <li>• Can be checked on the LCD screen</li> </ul>

	Type N	Type A	Type P	Type S
Communication	<ul style="list-style-type: none"> <li>• USB [for on-site operator] (Communication type only)</li> </ul>	<ul style="list-style-type: none"> <li>• USB [for on-site operator]</li> <li>• RS485 / Modbus (Communication type only)</li> </ul>	<ul style="list-style-type: none"> <li>• USB [for on-site operator]</li> <li>• RS485 / Modbus</li> </ul>	<ul style="list-style-type: none"> <li>• USB [for on-site operator]</li> <li>• RS485 / Modbus</li> <li>• BLE</li> <li>• NFC</li> </ul>
Power	<ul style="list-style-type: none"> <li>• [Operation when 30% or more of rated current, based on single-phase load standard]</li> </ul>	<ul style="list-style-type: none"> <li>• [Operation when 30% or more of rated current, based on single-phase load standard]</li> <li>• AC/DC 88 ~ 264V</li> <li>• DC 24 ~ 48V(Future development)</li> </ul>	<ul style="list-style-type: none"> <li>• [Operation when 30% or more of rated current, based on single-phase load standard]</li> <li>• AC/DC 88 ~ 264V</li> <li>• DC 24 ~ 48V(Future development)</li> </ul>	<ul style="list-style-type: none"> <li>• [Operation when 30% or more of rated current, based on single-phase load standard]</li> <li>• AC/DC 88 ~ 264V</li> <li>• DC 24 ~ 48V(Future development)</li> </ul>
Event record	<ul style="list-style-type: none"> <li>• 255 device status changes [Details, status, date]</li> </ul>	<ul style="list-style-type: none"> <li>• 255 device status changes [Details, status, date]</li> </ul>	<ul style="list-style-type: none"> <li>• 255 device status changes [Details, status, date]</li> </ul>	<ul style="list-style-type: none"> <li>• 255 device status changes [Details, status, date]</li> </ul>
Clock	<ul style="list-style-type: none"> <li>• RTC built-in (Back up with battery)</li> </ul>	<ul style="list-style-type: none"> <li>• RTC built-in (Back up with battery)</li> </ul>	<ul style="list-style-type: none"> <li>• RTC built-in (Back up with battery)</li> </ul>	<ul style="list-style-type: none"> <li>• RTC built-in (Back up with battery)</li> </ul>
Other LED	<ul style="list-style-type: none"> <li>• Run, alarm, Self-diagnosis, comm.</li> </ul>	<ul style="list-style-type: none"> <li>• Run, alarm, Self-diagnosis, comm.</li> </ul>	<ul style="list-style-type: none"> <li>• Run, alarm, Self-diagnosis, comm.</li> </ul>	<ul style="list-style-type: none"> <li>• Run, alarm, Self-diagnosis, comm.</li> </ul>
Operation button	<ul style="list-style-type: none"> <li>• Reset button</li> </ul>	<ul style="list-style-type: none"> <li>• Reset/menu/tap/up/down/enter</li> </ul>	<ul style="list-style-type: none"> <li>• Reset button</li> <li>• LCD Touch</li> </ul>	<ul style="list-style-type: none"> <li>• Reset button</li> <li>• LCD Touch</li> </ul>
LED	<ul style="list-style-type: none"> <li>• RUN/AL LED flashing (Red ↔ Blue flashing)</li> </ul>	<ul style="list-style-type: none"> <li>• RUN/AL LED flashing (Red ↔ Blue flashing)</li> </ul>	<ul style="list-style-type: none"> <li>• RUN/AL LED flashing (Red ↔ Blue flashing)</li> </ul>	<ul style="list-style-type: none"> <li>• RUN/AL LED flashing (Red ↔ Blue flashing)</li> </ul>
	LCD	<ul style="list-style-type: none"> <li>• Displays the corresponding segment or error number on the LCD</li> </ul>	<ul style="list-style-type: none"> <li>• Can be checked on the LCD self-diagnosis screen</li> </ul>	<ul style="list-style-type: none"> <li>• Can be checked on the LCD self-diagnosis screen</li> </ul>
Self-diagnosis List	<ul style="list-style-type: none"> <li>• Battery Low Alarm : Occurs when the internal battery is not inserted or when the battery voltage is low</li> <li>• Rating Plug Unattached or Error : Occurs when rating plug is not assembled or when there is rating plug error</li> <li>• Ampere Frame Error : Occurs when the value of rating plug is not within 45%~100% of AF</li> <li>• MTD Fail : Occurs when STU is not assembled with MTD or trip coil disconnection occurs</li> <li>• Factory Cfg Error : Occurs when the factory mode setting is entered incorrectly</li> <li>• Device Type Error : Occurs when the rating plug information and CT information are different</li> <li>• Over Heat Error : Occurs when CPU internal temperature N/A type exceeds 100 degrees and P/S type exceeds 115 degrees</li> <li>• Contact Wear Alarm : Occurs when CPU internal temperature N/A type exceeds 100 degrees and P/S type exceeds 115 degrees</li> <li>• Electrical Open Count Over Alarm : Occurs when the electrical open count exceeds 80% of the allowable electrical open count</li> <li>• Mechanical Open Count Over Alarm : Occurs when the mechanical open count exceeds 80% of the allowable mechanical open count</li> <li>• RTC Error : Occurs when an error occurs in the internal RTC information</li> <li>• Memory Error : Occurs when corruption occurs in the redundant internal settings stored in the internal non-volatile memory</li> <li>• CT disconnection error : Occurs when CT disconnection occurs (monitoring by each phase)</li> </ul>			

# Smart ACB Accessory



## TRIO

This device is installed on a low-pressure panel or distribution panel to monitor ACB status, remotely open and close operation control, and measure temperature.

DI/DO expansion is possible by linking with communication with STU.

### Features

TRIO module can monitor temperature by attaching a separate temperature sensor, and it has built-in DI/DO expansion function, so it can monitor and control the circuit breaker. Compared to the existing TRIO, the number of DI/DO contacts has increased, and the temperature display has been improved to 7-Segment level.

### Specifications

Type	Details	Remark
Model name	TRIO	
Rated voltage	DC24V (±10%)	21.6~26.4Vdc
Power consumption	6W or less	
Temperature sensor	4EA	Measurement range : 0~150 °C Error range : ± 3 °C for contact, 5 °C for non-contact Alarm temperature : 55 °C, 65 °C, 70 °C, 80 °C Digital output connection possible Temperature sensor sold separately
DI	General : 4EA CB : 2EA	Cradle status contact monitoring and spring charge status monitoring are possible
DO	General : 3EA CB : 2EA	LATCH, 500ms can be set (CB control possible)
LED	Power LED Comm. LED 3 CB LEDs 4 DI LEDs 3 DO LEDs 4 temperature sensor LEDs	Temperature display 7-Segment 99 °C or less : Display to 1 decimal place 100 °C or more : 1-digit display
Protocol	Modbus RTU	
Communication method	RS485	STU connection possible
Installation type	DIN-Rail, Screw	
Size	72 (W) × 81 (H) × 65 (D), unit : mm	
Use temperature	-25 °C ~ +60 °C	
Storage temperature	-30 °C ~ +70 °C	
Ambient humidity	Within 85% RH, no condensation	

### Exterior description

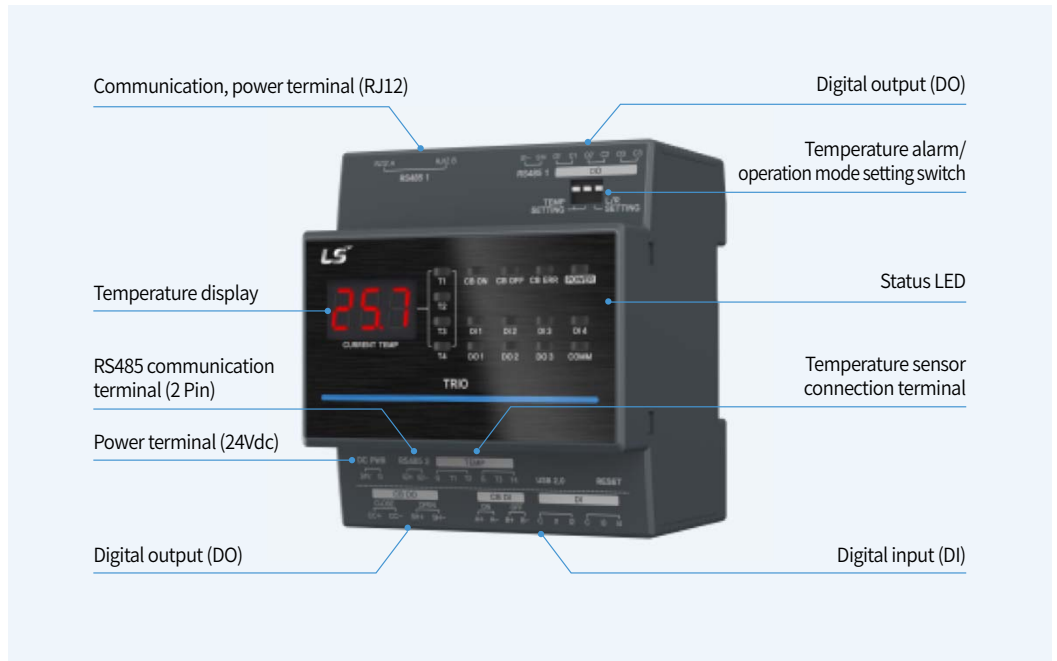

### Device usage example



### Target device

Circuit breaker Susol ACB STU, Metasol ACB STU

※Can be used alone

# Smart Trip Unit

## Control circuit diagram

This diagram is based on "CONNECTED" position of a circuit breaker and Opening, Motor charging,

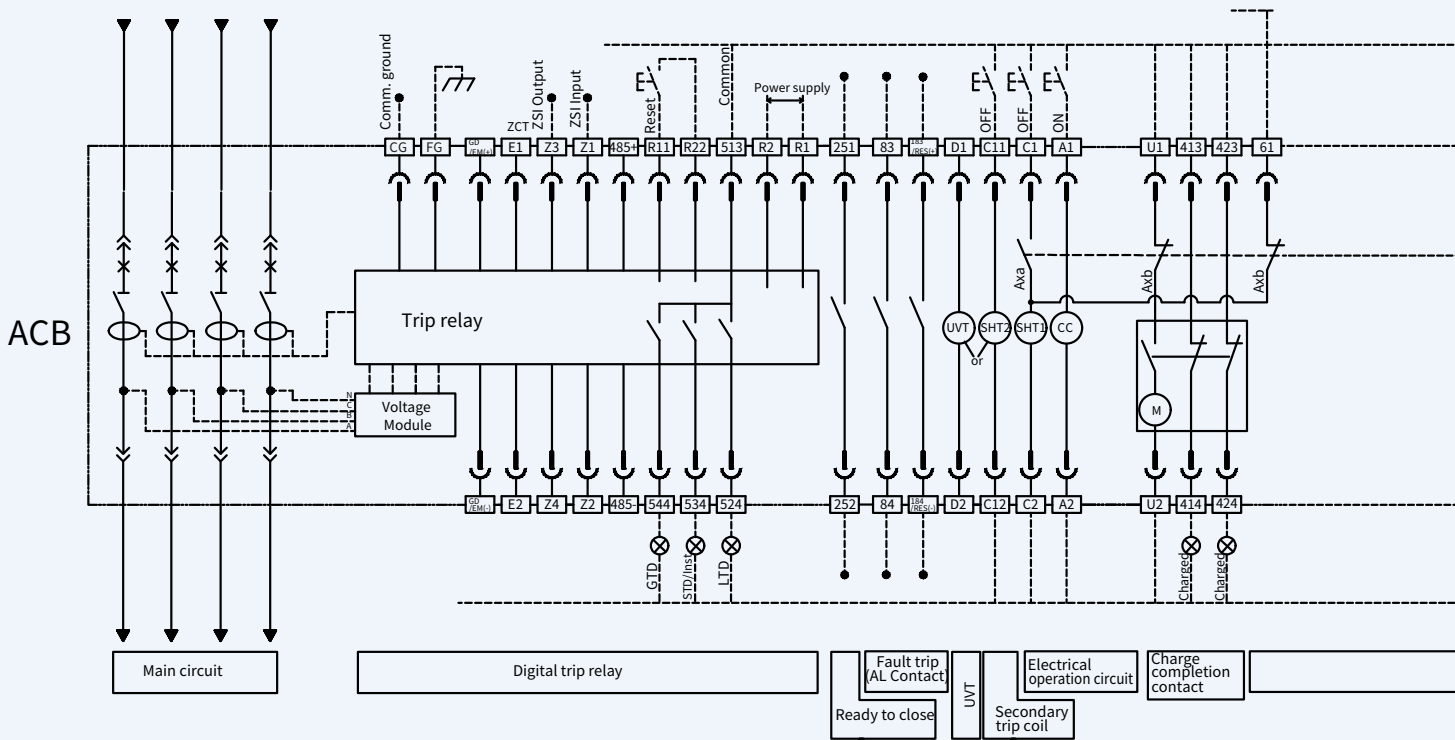

### Terminal code description

13	14	~	63	64	Auxiliary switch "NO"
11	12	~	61	62	Auxiliary switch "NC"
413	414				Charged signal
423	424				Charged signal communication
U1	U2				Motor charging
A1	A2				Closing coil
C1	C2				Shunt trip
C11	C12				2nd shunt trip

D1	D2	Voltage input terminal of UVT	
83	84	Alarm1 "NO"	
183	184	Alarm2 "NO"	
251	252	Ready to close switch	
R1	R2	Control Power	
513	~	544	Alarm contact
R11	R22	Alarm reset (Trip cause LED, Alarm contact)	
485+	485-	RS-485 communication	

Z1	Z2	ZSI input			
Z3	Z4	ZSI output			
E1	E2	ZCT			
EB EM(+)	EB EM(-)	Group DI or ERMS DI			
FG		Frame ground			
CG		Communication Ground			
TC1	TC2	~	T1	T2	Temperature module
311	~	344			Position switch
911	~	914			EARTHING TRUCK

Note) 1. The diagram is shown with circuit de-energized, all devices open, connected and charged and relays in normal position

2. Relay is normal condition and charging type is "OFF-Charging"

3. The standard of auxiliary contact is 3a3b. The auxiliary switch in above diagram is composed of 5a5b. See 48 page for more detail on auxiliary switches.

4. Option

- Ready to close contact, Trip alarm contact, UVT coil, Fully charged contact, secondary trip coil
- Cell switch, Temperature module, Voltage module, Remote close-open module, ZCT, ZSI

5. Please consult us for the use of ZSI (Zone selective Interlocking).

6. Refer to the page 33 for the connection of Trip relay and the page 43 for UVT.

7. For connecting RS-485 verify if the polarity is correct

8. Contact configuration for Cell Switch can be changeable if necessary

Releasing of locking plate should be normal condition.

TRIP COIL SUPERVISION(OPTION)

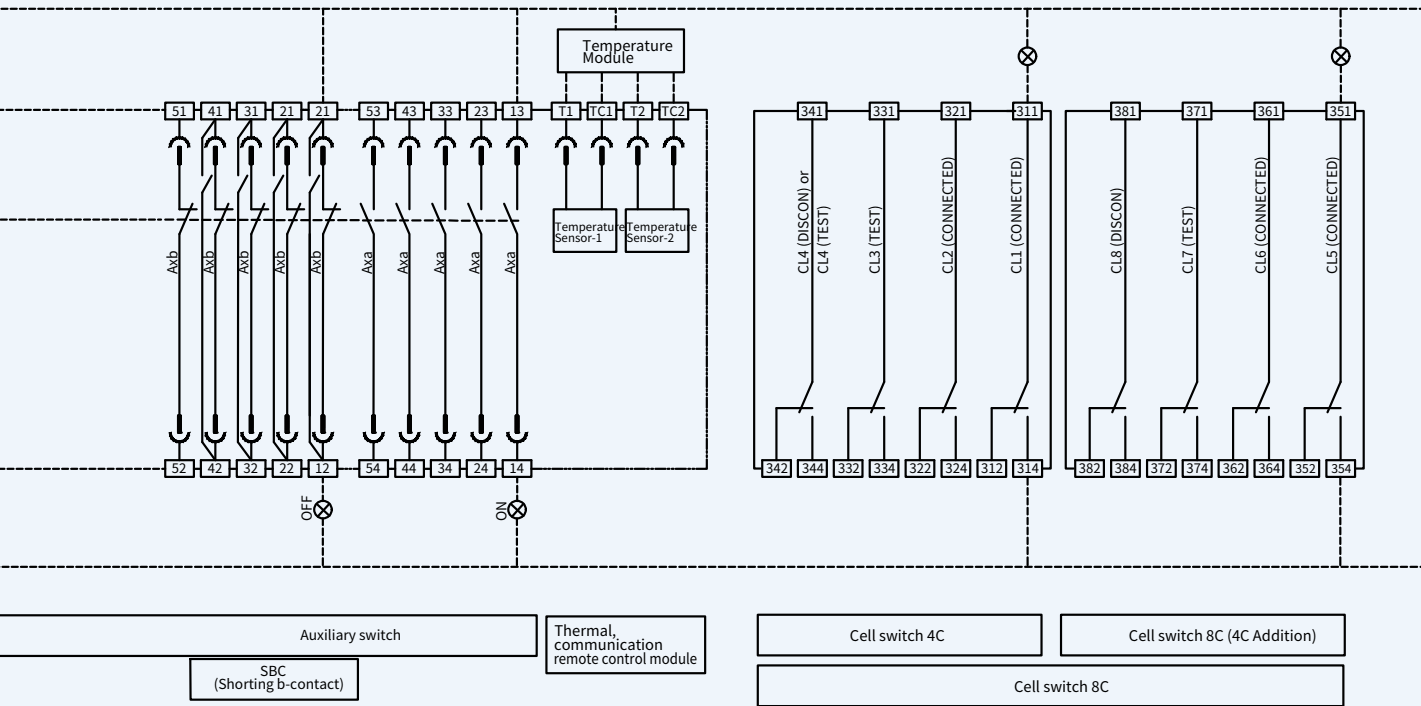

Accessory code description

Axa , Axb	Auxiliary switch
LTD	Long time delay trip indicator
STD/Inst	Short time delay/instantaneous
GTD	Ground fault trip indicator
CL1-CL4	Cell switch
Ⓜ	Motor
Ⓢ	Closing coil
ⓈT1	Shunt tripping device 1
ⓈT2	Shunt tripping device 2
ⓈV	UVT coil

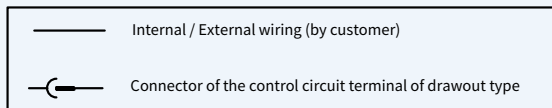

# Smart Trip Unit

## System diagram

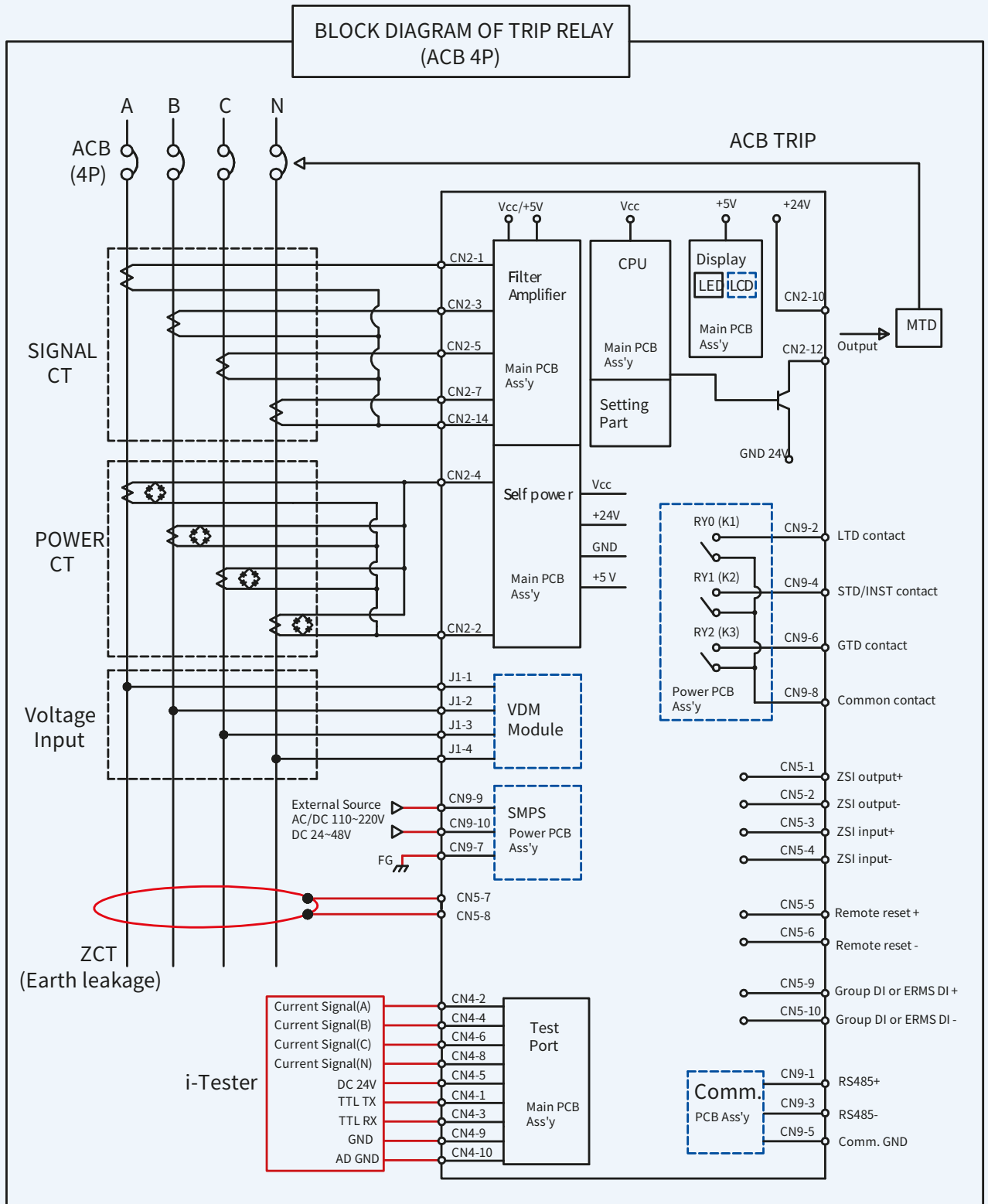

Note: 1. The red display part is for the option order and the user must wire directly.  
 2. The blue display part must be ordered according to the required specifications when ordering a trip relay.



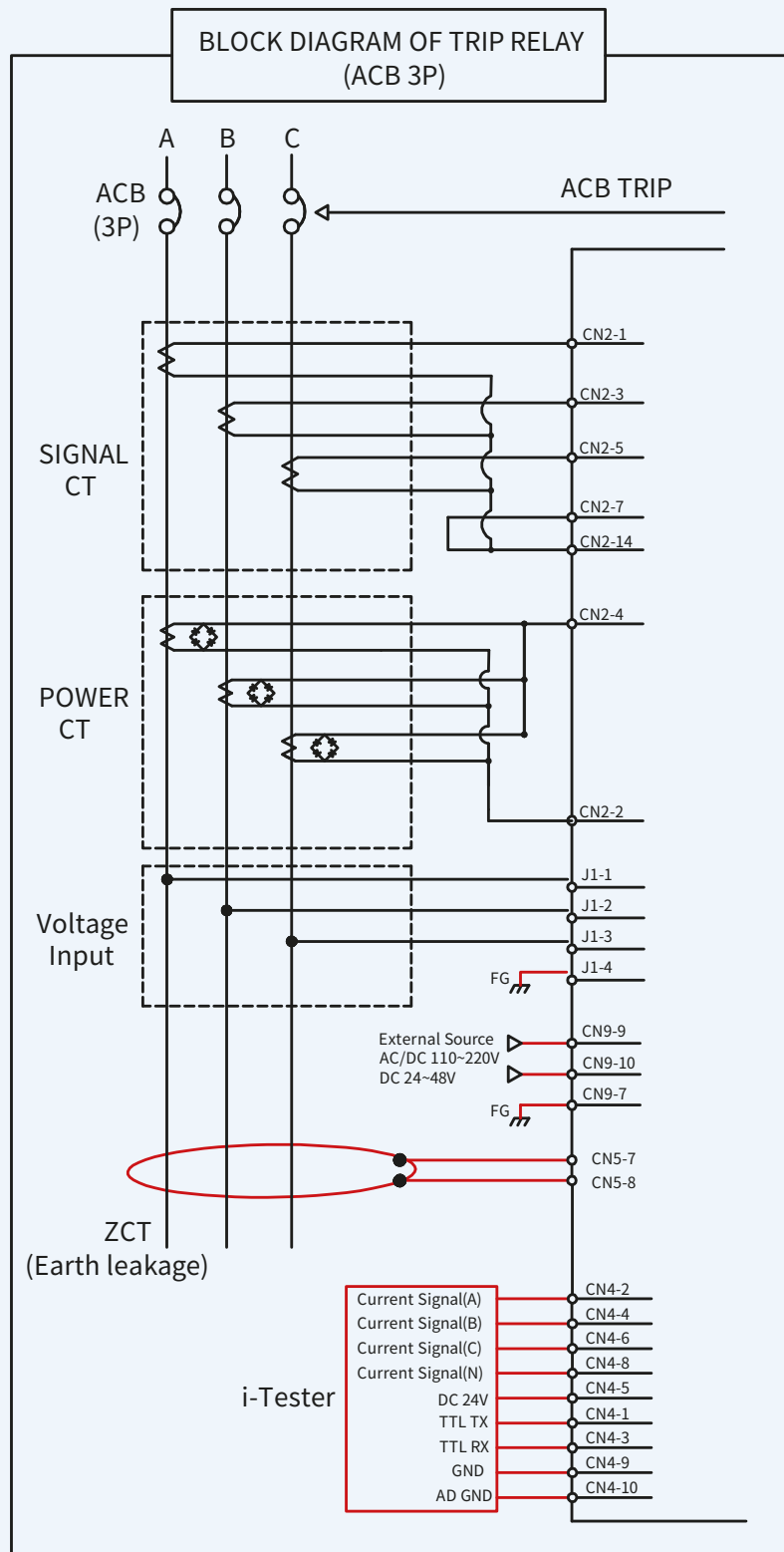

**Susol**

# Smart Molded Case Circuit Breakers

Susol Smart MCCB is developed by combining digital technology with LS ELECTRIC's power device technology accumulated over 40 years. The relay and measurement functions for line protection has been upgraded.

By using accessory devices for connectivity between low-voltage devices, it is possible to diagnose and maintain devices by collecting and analyzing data.





# Susol Smart MCCB

---

## 1. Overview

- Susol MCCB Overview ..... 50

## 2. Features

- Susol MCCB features ..... 54

## 3. Model selecting guide

- Susol MCCB model numbering (Product selection) ..... 56

## 4. External structure and notation ..... 58

## 5. Rated specifications ..... 60

## 6. Smart Trip Unit ..... 64

---

# Susol MCCB Overview



Ics=100% Icu : 50, 65, 85, 100, 150kA at 415Vac

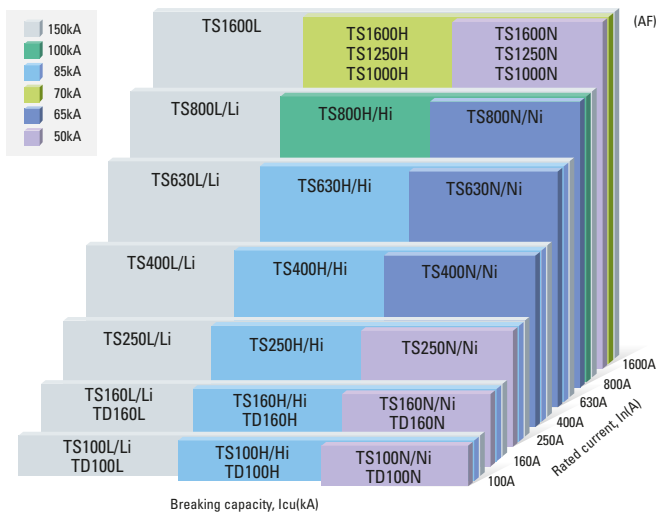

## TS100/160/250

Rated current : 40~250A  
 Icu : 50kA (N/Ni), 85kA (H/Hi), 150kA (L/Li)  
 Ics = Icu  
 105 (W) × 160 (H) × 86mm (D)

## TD100/160

Rated current : 16~160A  
 Icu : 50kA (N), 85kA (H), 150kA (L)  
 Ics = Icu  
 90 (W) × 140 (H) × 86mm (D)



## Super performance

The third breaking performance guarantees  
the original performance.

Icu 150kA

Ui 1000V

Uimp 8kV

5 Frames

### TS400/630

Rated current : 300~630A  
Icu : 65kA (N/Ni), 85kA (H/Hi), 150kA (L/Li)  
Ics = Icu  
140 (W) × 260 (H) × 110mm (D)



### TS800

Rated current : 700, 800A  
Icu : 65kA (N/Ni), 100kA (H/Hi), 150kA (L/Li)  
Ics = Icu  
210 (W) × 320 (H) × 135mm (D)



### TS1600

Rated current : 1000, 1250, 1600A  
Icu : 50kA (N), 70kA (H), 150kA (L)  
Ics = Icu  
210 (W) × 327 (H) × 152.5mm (D)



# Susol MCCB features

## Susol Smart MCCB



### Susol circuit breaker's Brain-Trip unit

The trip unit has the core function of monitoring the system and sending an interruption (trip) signal when an error occurs. The Susol circuit breaker have optional adjustable devices for each item as well as simple fixed trip devices. It provides the optimal solution for selection according to the type of load and operation coordination between upper and lower circuit breakers.

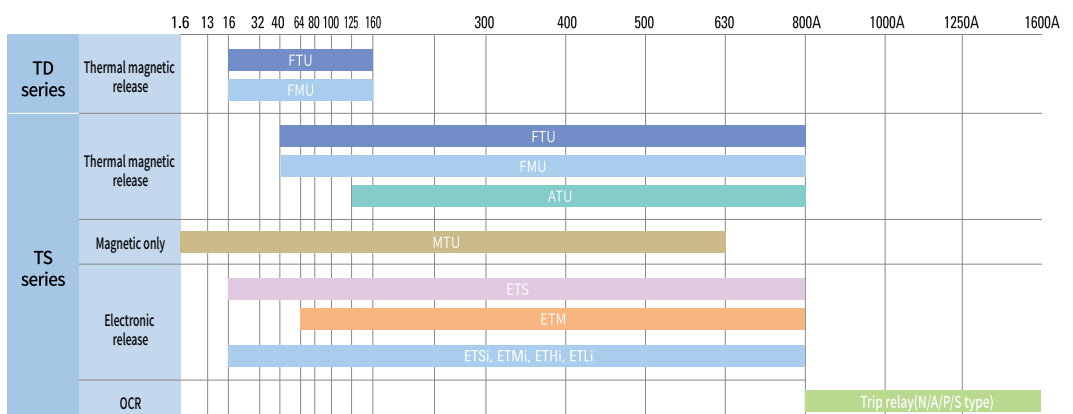

## Optimal Solution-Trip unit

Type	TD Seris	TS Series			
					
Rated current	16 ~ 160A	40 ~ 800A	40 ~ 800A	800 ~ 1600A	
Trip unit	Thermal electronic type	FMU FTU	FMU FTU ATU	-	DSU
	Magnetic only	-	MTU <i>Note 1)</i>	-	-
	Electronic release	-	ETS ETM <i>Note 2)</i>	ETSi ETMi ETHi ETLi	-
	Switch	DSU	DSU	-	DSU
	OCR	-	-	-	N type A type P type S type

Note 1) 1.6-630A    Note 2) 64-800A

## 100~800AF

### For line and device protection

#### 1. Thermal magnetic trip units

- FTU : Fixed thermal, fixed magnetic trip unit
- FMU : Adjustable thermal, fixed magnetic trip unit
- ATU : Adjustable thermal, adjustable magnetic trip unit

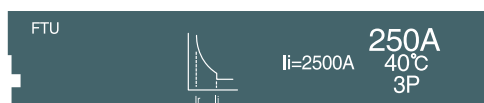

#### 2. Electronic trip units

- ETS/ ETSi : Standard
- ETM/ ETMi : Multi-Function
- ETHi : High-Performance
- ETLi : Limited-Performance



### For motor protection

MTU : Magnetic only trip unit

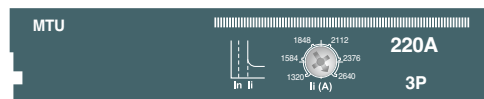





### For switch disconnector

DSU : Disconnecting switch unit



## 1000~1600AF trip relay (OCR)

N type	A type	P type	S type
			
Regular type	Ammeter type	Power meter type	High performance meter type

# Susol MCCB features

## Susol Smart MCCB

Susol Smart MCCB was developed by integrating digital technology based on power device technology accumulated over 40 years. Relay and measurement functions for line protection have been upgraded, and by using accessory devices for connectivity between low - voltage devices, data can be collected and analyzed to diagnose and maintain devices. LS ELECTRIC takes the lead for a smart future with energy digitalization.

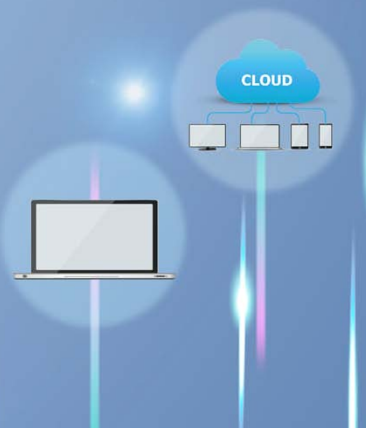

Susol Circuit Breaker + Digital Technology



Susol Smart MCCB

## Applicable field

The movement for energy digitalization is taking place in various fields.

Susol Smart MCB can be applied to areas such as renewable energy, buildings, industry, and EV charging infrastructure linked to low pressure, in order to safely protect the line with LSIG relay function.



Renewable energy generation



Infrastructure



Residential/Commercial



Industrial



EV charging infrastructure



## Susol MCCB and Susol Smart MCCB device specifications

### Common specifications

- Breaking capacity and exterior size
- Insulation voltage upgrade : 750V → 1000V
- Compatible with existing accessories

### Susol Smart MCCB features

- Fine relay function that can be finely adjusted : LSIG (Long time protection against overload, Short circuit protection, Instantaneous protection, Earth fault protection)
- Upgraded measurement accuracy : Current Class 1, Voltage  $\pm 0.5\%$ , Power and Power Class 2
- Device diagnosis and maintenance
- Dark gray exterior color with new PI



### Electronic trip device specification comparison

Type	Susol MCCB		Susol Smart MCCB			
	ETS	ETM	ETSi	ETMi	ETHi	ETLi
Frame size	250/630/800AF	630/800AF	250/630/800AF			
Line protection	Long time, short circuit, instantaneous	■	■	■	■	■
	Ground fault		Option	■	■	■
Measurement information	Current	-	■	■	■	■
	Voltage, frequency, power factor, power quantity, power quality, etc.	-	-	-	■	■
Device operation	System event, fault event (Up to 50)	-	One	-	■	■
	Operating time, mechanical frequency, electrical frequency, trip frequency, load usage rate	-	-	-	■	■
	Contact wear rate	-	-	-	-	■
Communication	RS485	-	■	-	■	■
	Mobile communication	-	-	-	-	■

•ETS/ETSi: Standard

•ETM/ETMi: Multi-Function

•ETHi: High-Performance

•ETLi: Limited-Performance

# Model selecting guide

## Smart MCCB (Trip unit : ETSi, ETMi, ETHi, ETLi) Model numbering (Product selection)

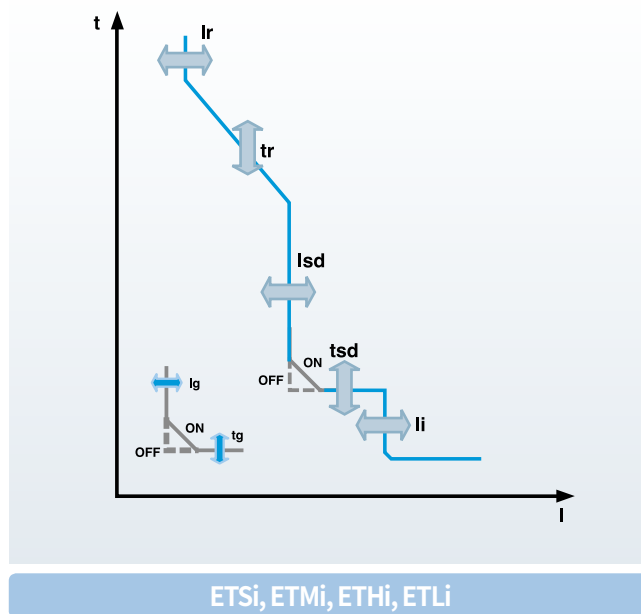
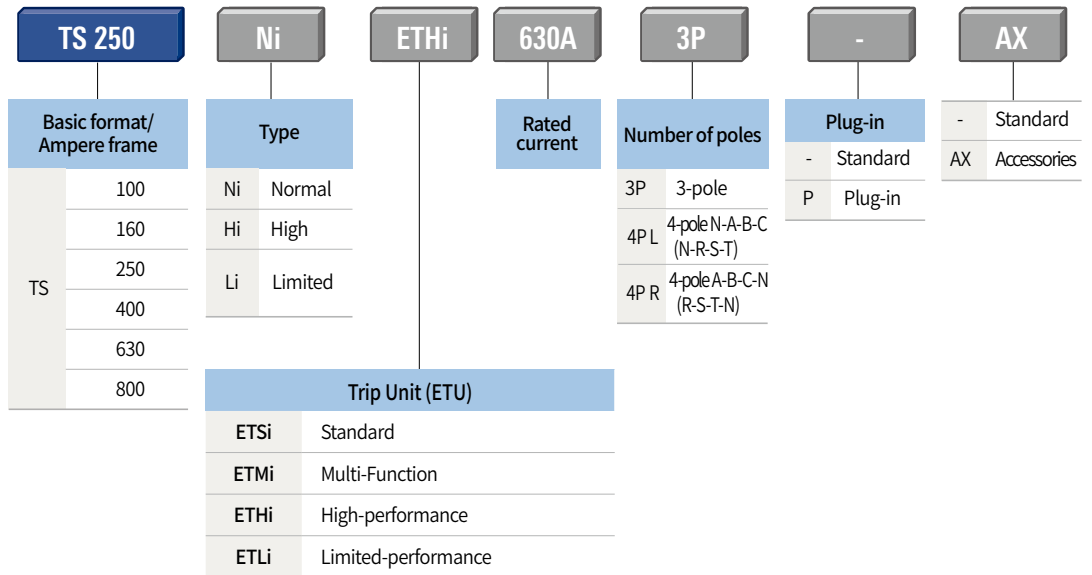

*New standard for low voltage circuit breakers*

## **Susol Smart MCCB**

Susol Smart MCCB is developed by combining digital technology with LS ELECTRIC's power device technology accumulated over 40 years. The relay and measurement functions for line protection has been upgraded. By using accessory devices for connectivity between low-voltage devices, it is possible to diagnose and maintain devices by collecting and analyzing data.



# External structure and notation



Rated frequency

Standard

Certification mark

Utilization category

Symbol indicating suitability for isolation as defined by IEC60947-2



Alarm Indication LED

Test terminal

Overcurrent indication LED

Unlock Key

**Circuit breaker model (Type/Model)**

- TS: TS series
- 250 : Frame size
- Ni : Normal (Standard)
- Hi : High
- Li : Limited

**Circuit breaker performance**

- Ui : Rated insulation voltage
- Uimp : Impulse withstand voltage
- Ue : Rated operational voltage
- Icu : Ultimate breaking capacity
- Ics : Service breaking capacity

	250AF	630AF	800AF
Ni	TS100Ni TS160Ni TS250Ni	TS400Ni TS630Ni -	TS800Ni - -
Hi	TS100Hi TS160Hi TS250Hi	TS400Hi TS630Hi -	TS800Hi - -
Li	TS100Li TS160Li TS250Li	TS400Li TS630Li -	TS800Li - -
Ni	50kA	65kA	65kA
Hi	85kA	85kA	100kA
Li	150kA	150kA	150kA

**CB Test certificate by UL**

- Ref.Certificate No. : DK-85164-UL
- Standard No. IEC60947-2

- Company logo
- Upstream connections
- Attachment Hole
- Indication of closed (I/ON) position
- Indication of closed (I/ON) position
- Operation handle
- Indication of open (O/OFF) position
- Trip test button
- Trip device type
- Rating of trip unit
- Trip unit operation button
- Attachment hole
- Downstream connections



Ref. Certif. No.

**DK-85164-UL**

IEC SYSTEM FOR MUTUAL RECOGNITION OF TEST CERTIFICATES FOR ELECTRICAL EQUIPMENT (IECEE) CB SCHEME

**CB TEST CERTIFICATE**

**Product** Moulded-Case Circuit Breaker

**Name and address of the applicant** LSIS CO LTD  
127 LS-ro Dongan-gu  
Anyang-si, 14119 Gyeonggi-do Korea

**Name and address of the manufacturer** LSIS CO LTD  
127 LS-ro Dongan-gu  
Anyang-si, 14119 Gyeonggi-do Korea

**Name and address of the factory** LSIS CO LTD  
95 Baekbong-ro Heundeok-gu  
Chungcheong-si, 361-720 Chungcheongbuk-do Korea  
 Additional information on page 2

**Additional information (if necessary may also be reported on page 2)**  Additional information on page 2

**A sample of the product was tested and found to be in conformity with** IEC 60947-1:2007/AMD1:2010, IEC 60947-1:2007/AMD2:2014, IEC 60947-2:2011, IEC 60947-2:2016

**As shown in the Test Report Ref. No. which forms part of this Certificate** 4788765951 issued on 2019-06-21

This CB Test Certificate is issued by the National Certification Body



- UL (US), 333 Pingree Rd E, 63062, Northbrook, USA
- UL (Denmark), Borupvang 5A DK-2750 Ballerup, DENMARK
- UL (JP), Marunouchi Trust Tower Main Building 8F, 1-8-3 Marunouchi, Chiyoda-ku, Tokyo 100-0005, JAPAN
- UL (CA), 7 Underwriters Road, Toronto, M1R 3B4 Ontario, CANADA

**Date:** 2019-06-28 **Signature:**   
Jan-Erik Storgaard

For full legal entity names see www.ul.com/cb-schemes

# Rated specifications

## Susol Smart MCCB

When selecting a device, Susol Smart MCCB selects the type and rating of the main body and trip device, respectively.



### Frame

Optional  
 - Model numbering (Example : TS100)  
 - Number of poles (Example : 3 poles)  
 - Breaking capacity (Example: Ni 50kA/460V)

Electronic trip unit

### Trip Unit

Optional  
 - Trip Unit type (Example : ETSi)  
 - Rated current (Example : 100A)

L : Long time protection against overload  
 S : Short circuit protection  
 I : Instantaneous protection  
 G : Earth fault protection

ETSi (basic type)  
 LSiG relay, current measurement



ETMi (Multi - function)  
 LSiG relay, current measurement, communication function

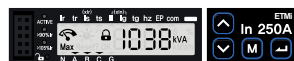

ETHi (High - Performance)  
 LSiG relay, current/voltage/ power measurement,



LSiG relay, current/voltage/ power measurement, communication function, mobile communication



### Frame

Model	TS100	TS160	
Frame size [AF]	100	160	
Number of poles	3, 4	3, 4	
[Pole]	TypeType Ni Hi Li Ni Hi Li		
Rated breaking current, Icu	220/240V [kA]	100 120 200	100 120 200
	380/415V [kA]	50 85 150	50 85 150
	440/460V [kA]	50 70 130	50 70 130
	480/500V [kA]	42 65 85	42 65 85
	525V [kA]	22 35 50	22 35 50
660/690V [kA]	10 10 10	10 10 10	

### Trip Unit

Rated current	In	40, 100	40, 100, 160
Overload protection setting current (Long time)	I <sub>r</sub>	0.4 × I <sub>n</sub> ~ 1.0 × I <sub>n</sub> (1A unit)	
Tripping time (Long time)	t <sub>r</sub>	0.5, 1.2, 4, 8, 16 (second)	
Short circuit protection setting current	I <sub>sd</sub>	1.5 ~ 10 × I <sub>r</sub> (0.5 unit)	
Tripping time (Short circuit)	t <sub>sd</sub>	I <sup>2</sup> t Off : 0, 0.1, 0.2, 0.3, 0.4 (second) I <sup>2</sup> t On : 0.1, 0.2, 0.3, 0.4 (second)	
Instantaneous protection setting current	I <sub>i</sub>	40~160A : 1.5 ~ 15 × I <sub>n</sub> (0.5 unit) 250~400A : 1.5 ~ 12 × I <sub>n</sub> (0.5 unit) 630~800A : 1.5 ~ 11 × I <sub>n</sub> (0.5 unit)	
Earth fault protection setting current	I <sub>g</sub>	40A : 0.45 ~ 1.0 × I <sub>n</sub> (0.05 unit) 100A : 0.35 ~ 1.0 × I <sub>n</sub> (0.05 unit) 160A : 0.25 ~ 1.0 × I <sub>n</sub> (0.05 unit) I <sub>n</sub> > 160A : 0.2 ~ 1.0 × I <sub>n</sub> (0.05 unit)	
Tripping time (Earth fault)	t <sub>g</sub>	I <sup>2</sup> t Off : 0, 0.1, 0.2, 0.3, 0.4 (second) I <sup>2</sup> t On : 0.1, 0.2, 0.3, 0.4 (second)	
Additional functions		Selective protection (ZSI)	



TS250			TS400			TS630			TS800		
250			400			630			800		
3, 4			3, 4			3, 4			3, 4		
Ni	Hi	Li	Ni	Hi	Li	Ni	Hi	Li	Ni	Hi	Li
100	120	200	100	120	200	100	120	200	100	120	200
50	85	150	65	85	150	65	85	150	65	100	150
50	70	130	65	85	130	65	85	130	65	100	130
42	65	85	42	65	85	42	65	85	42	85	100
22	35	50	22	35	50	22	35	50	22	35	50
10	10	10	10	20	35	10	20	35	10	20	35
40, 100, 160, 250			250, 400			250, 400, 630			630, 800		
0.4 × In ~ 1.0 × In (1A unit)											
0.5, 12, 4, 8, 16 (second)											
1.5 ~ 10 × Ir (0.5 unit)											
I <sup>2</sup> t Off : 0, 0.1, 0.2, 0.3, 0.4 (second) I <sup>2</sup> t On : 0.1, 0.2, 0.3, 0.4 (second)											
40~160A : 1.5 ~ 15 × In (0.5 unit) 250~400A : 1.5 ~ 12 × In (0.5 unit) 630~800A : 1.5 ~ 11 × In (0.5 unit)											
40A : 0.45 ~ 1.0 × In (0.05 unit) 100A : 0.35 ~ 1.0 × In (0.05 unit) 160A : 0.25 ~ 1.0 × In (0.05 unit) In > 160A : 0.2 ~ 1.0 × In (0.05 unit)											
I <sup>2</sup> t Off : 0, 0.1, 0.2, 0.3, 0.4 (second) I <sup>2</sup> t On : 0.1, 0.2, 0.3, 0.4 (second)											
Selective protection (ZSI)											

# Rated specifications

## Susol Smart MCCB



Type			TS100			TS160		
Fame size	[AF]		100			160		
Rated current, In	[A]		40, 100			40, 100, 160		
No. of poles			3, 4			3, 4		
Rated operational voltage, Ue [AC]	[V]		690			690		
Rated impulse withstand voltage, Uimp	[kV]		8			8		
Rated insulation voltage, Ui	[V]		1000			1000		
			Ni	Hi	Li	Ni	Hi	Li
Rated ultimate short-circuit breaking capacity, Icu	AC 50/60Hz	220/240V [kA]	100	120	200	100	120	200
		380/415V [kA]	50	85	150	50	85	150
		440/460V [kA]	50	70	130	50	70	130
		480/500V [kA]	42	65	85	42	65	85
		525V [kA]	22	35	50	22	35	50
		660/690V [kA]	10	10	10	10	10	10
Rated service breaking capacity, Ics	AC 50/60Hz	220/240V [kA]	100	120	200	100	120	200
		380/415V [kA]	50	85	150	50	85	150
		440/460V [kA]	50	70	130	50	70	130
		480/500V [kA]	42	65	85	42	65	85
		525V [kA]	22	35	50	22	35	50
		660/690V [kA]	5	5	5	5	5	5
Rated short-circuit making capacity, Icm	AC 50/60Hz	220/240V [kA]	220	265	440	220	264	440
		380/415V [kA]	105	187	330	105	187	330
		440/460V [kA]	105	154	286	105	154	286
		480/500V [kA]	88	143	187	88	143	187
		525V [kA]	46	74	105	46	74	105
		660/690V [kA]	17	17	17	17	17	17
Category fo utilization			A			A		
Isolation behavior			■			■		
Trip unit(release) : Electronics		ETSi	■			■		
		ETMi	■			■		
		ETHi	■			■		
		ETLi	■			■		
Connection	fixed	front-connection	■			■		
		rear-connection	■			■		
	plug-in	front-connection	■			■		
		rear-connection	■			■		
Basic dimensions, W × H × D	3-pole [mm]	105 × 160 × 86			105 × 160 × 86			
(front-connection)	4-pole [mm]	140 × 160 × 86			140 × 160 × 86			





TS250			TS400			TS630			TS800		
250			400			630			800		
40, 100, 160, 250			250, 400			250, 400, 630			630, 800		
3, 4			3, 4			3, 4			3, 4		
690			690			690			690		
8			8			8			8		
1000			1000			1000			1000		
Ni	Hi	Li	Ni	Hi	Li	Ni	Hi	Li	Ni	Hi	Li
100	120	200	100	120	200	100	120	200	100	120	200
50	85	150	65	85	150	65	85	150	65	100	150
50	70	130	65	85	130	65	85	130	65	100	130
42	65	85	42	65	85	42	65	85	42	85	100
22	35	50	22	35	50	22	35	50	22	35	50
10	20	35	10	20	35	10	20	35	10	20	35
100	120	200	100	120	200	100	120	200	100	120	200
50	85	150	65	85	150	65	85	150	65	100	150
50	70	130	65	85	130	65	85	130	65	100	130
42	65	85	42	65	85	42	65	85	42	85	100
22	35	50	22	35	50	22	35	50	22	35	50
5	5	5	10	12	12	10	12	12	10	20	20
220	264	440	220	264	440	220	264	440	220	264	440
105	187	330	143	187	330	143	187	330	143	220	330
105	154	286	143	187	286	143	187	286	143	220	286
88	143	187	88	143	187	88	143	187	88	187	220
46	74	105	46	74	105	46	74	105	46	74	105
17	17	17	17	40	74	17	40	74	17	40	74
A			A			A			A		
■			■			■			■		
■			■			■			■		
■			■			■			■		
■			■			■			■		
■			■			■			■		
■			■			■			■		
■			■			■			■		
■			■			■			■		
■			■			■			■		
105 × 160 × 86			140 × 260 × 110			140 × 260 × 110			210 × 320 × 135		
140 × 160 × 86			186.5 × 260 × 110			186.5 × 260 × 110			280 × 320 × 135		

# Smart Trip Unit

## Smart Trip Unit - ETSi, ETMi, ETHi, ETLi (Electronic)

### Trip Unit exterior



### Trip Unit type

ETU of Susol Smart MCCB is equipped with basic type (ETSi) that performs current measurement for each AF and rated current, and advanced type (ETMi) trip unit with communication function, a high-end (ETHi) trip unit that performs voltage measurement in communication functions, and various electronic trip units capable of mobile (BLE) communication (ETLi).

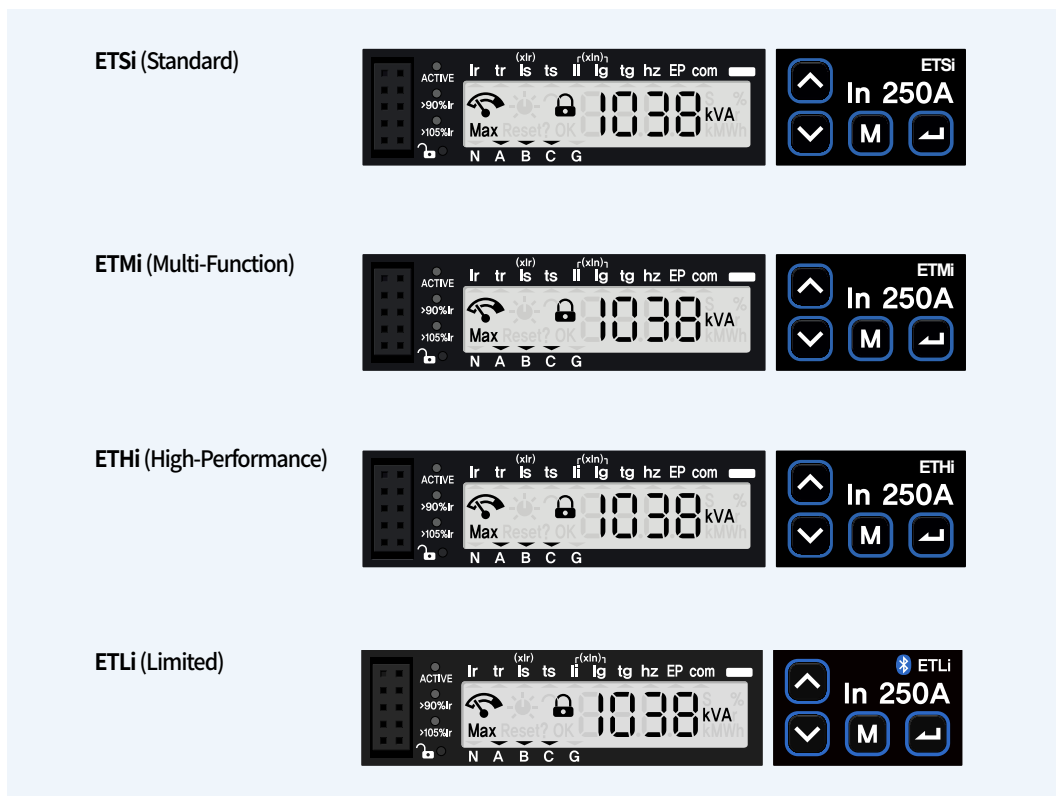

**Trip Unit  
Rated current**

AF	Rated current <sup>250</sup>
100AF	40A, 100A
160AF	40A, 100A, 160A
250AF	40A, 100A, 160A, 250A
400AF	250A, 400A
630AF	250A, 400A, 630A
800AF	630A, 800A

**Trip Unit  
features**

ETU	ETSi	ETMi	ETHi	ETLi
Relay (setting)	<p>Long time Short circuit Instantaneous Ground fault</p>			
Button	●	●	●	●
LCD	●	●	●	●
Status LED	●	●	●	●
Test Port	●	●	●	●
Measurement	Current	●	●	●
	Power	-	-	●
Communication	RS485	-	●	●
	BLE	-	-	●

# Smart Trip Unit

## Smart Trip Unit - ETSi, ETMi, ETHi, ETLi (Electronic)

### Overcurrent protection relay

Smart MCCB's ETU basically performs relay operation function for long time, short time, instantaneous and ground fault, and provides an alarm indicating LED related to overcurrent display.

Relay item setting for relay operation can be set by using the button on the front of ETU.

To change the relay action setting, press the 'unlock' button, change the setting in the 'unlock' state (🔓), and after completing the setting, press the 'unlock' button to switch to the 'lock' state (🔒).

During the setting change, if there is no button input for more than 1 minute, the device automatically switches to the 'lock' state (🔒).

Type	ETSi	ETMi	ETHi	ETLi
Relay setting	●	●	●	●

### Characteristic curve

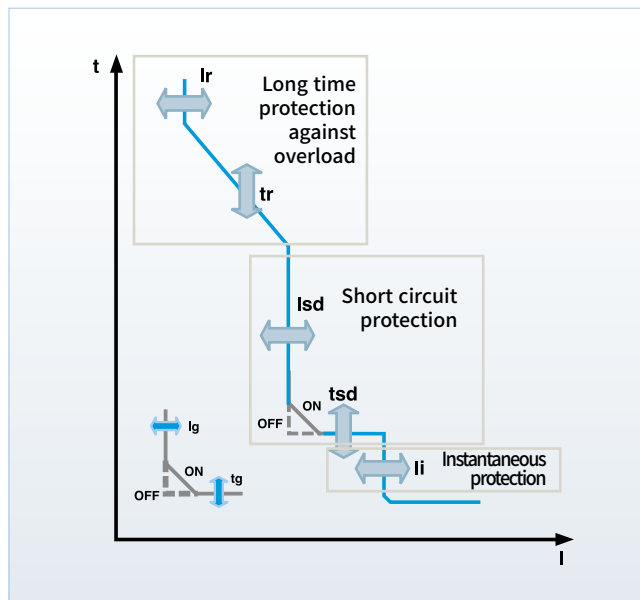

- 1) Long time overcurrent relay (Long time protection) : Performs caloric relay and the operating current ( $I_r$ ) and operating time ( $t_r$ ) can be set.
- 2) Short time overcurrent relay (Short time protection) : The operating current ( $I_{sd}$ ) and operating time ( $t_{sd}$ ) can be set.
- 3) Instantaneous overcurrent relay : The operating current ( $I_i$ ) can be set.
- 4) Ground fault relay (Ground fault protection) : You can set whether to use ground fault relay, operating current ( $I_g$ ) and operating time ( $t_g$ ).
- 5) N - phase protection relay : N-phase protection relay can be set for a 4-wire type instrument.
  - Off : No protection
  - 100% : N-phase protection for  $100\% \times I_r$
  - 50% : Perform N-phase protection for  $50\% \times I_r$
  - ON : Performs N-phase protection for  $160\% \times I_r$  when  $I_r$  setting is set to ' $<0.63xI_n$ '  
(Used for load usage conditions that contain a lot of harmonics)
- 6) ZSI (Zone Selective Interlocking) : Breaks the protected area selectively.

\*It is necessary to set the relay so that the circuit breaker does not malfunction due to inrush current.  
(In case of motor or capacitor load, inrush current of several times the rated current may occur.)

Relay  
specification table

Protection	Item	Setting range							Remark	
Long time (overload)	Operating current (I <sub>r</sub> )	Rated current	Min (0.4 × I <sub>n</sub> )			Max (1.0 × I <sub>n</sub> )			1A unit adjustment	
		40A	16A			40A				
		100A	40A			100A				
		160A	64A			160A				
		250A	100A			250A				
		400A	160A			400A				
		630A	252A			630A				
		800A	320A			800A				
	Operating time (tr) error range : ±20%	Operation time	Setting	0.5	1	2	4	8	16	Unit : seconds
			1.5 × I <sub>r</sub>	11	22	45	90	180	360	
6 × I <sub>r</sub>			0.5	1	2	4	8	16		
7.2 × I <sub>r</sub>			0.35	0.7	1.4	2.8	5.5	11		
Short circuit	Operating current (I <sub>sd</sub> ) error range : ±10%	1.5 × I <sub>r</sub> ~ 10 × I <sub>r</sub> (18 steps)							0.5 times unit adjustment	
		Setting	I <sup>2</sup> tOff	0	0.1	0.2	0.3	0.4		Unit : seconds
	I <sup>2</sup> tOn		-	0.1	0.2	0.3	0.4			
	Operating time (tr) error range : ±20%	I <sup>2</sup> tOff Operation time	Non - operation	0.02	0.08	0.14	0.24	0.35		
Maximum operation			0.08	0.14	0.24	0.35	0.50			
Instan- taneous	Operating current (I <sub>sd</sub> ) error range : ±15%	Setting	Rated current	Range					0.5 times unit adjustment	
			40A ~ 160A	1.5 × I <sub>n</sub> ~ 15 × I <sub>n</sub> (28 steps)						
			250A ~ 400A	1.5 × I <sub>n</sub> ~ 12 × I <sub>n</sub> (22 steps)						
			630A ~ 800A	1.5 × I <sub>n</sub> ~ 11 × I <sub>n</sub> (20 steps)						
Non - operation time : 10ms, Maximum operating time : 60ms										
Earth fault	Operating current (I <sub>sd</sub> ) error range : ±10%	Setting	Rated current	Range					0.05 times unit adjustment	
			40A	0.45 × I <sub>n</sub> ~ 1.0 × I <sub>n</sub> (12 steps)						
			100A	0.35 × I <sub>n</sub> ~ 1.0 × I <sub>n</sub> (14 steps)						
			160A	0.25 × I <sub>n</sub> ~ 1.0 × I <sub>n</sub> (16 steps)						
			I <sub>n</sub> > 160A	0.2 × I <sub>n</sub> ~ 1.0 × I <sub>n</sub> (17 steps)						
	Operating time (tr) error range : ±25%	Setting Operation time	I <sup>2</sup> tOff	0	0.1	0.2	0.3	0.4	Unit : seconds	
			I <sup>2</sup> tOn	-	0.1	0.2	0.3	0.4		
			Non - operation	0.02	0.08	0.14	0.24	0.35		
			Maximum operation	0.08	0.14	0.24	0.35	0.50		

# Smart Trip Unit

## Smart Trip Unit - ETSi, ETMi, ETHi, ETLi (Electronic)

### Measurement specification table

Type		ETU Type				Display	
		ETSi	ETMi	ETHi	ETLi	ETU	3.5" HMI
Current	Each phase current (Ia, Ib, Ic, In)	●	●	●	●	●	●
	Maximum current (Imax of Ia, Ib, Ic, In)	●	●	●	●	●	
	Ground fault current (I <sub>g</sub> )	●	●	●	●	●	
	Maximum ground fault current (Imax of I <sub>g</sub> )	●	●	●	●	●	
	Average current : I <sub>avg</sub> = (Ia + Ib + Ic)/3	●	●	●	●		
	Unbalance rate : I <sub>unbal</sub> (%) = (Imax - I <sub>avg</sub> )/I <sub>avg</sub>	●	●	●	●		
Voltage	Phase voltage (Va, Vb, Vc)/Line voltage (Vab, Vbc, Vca)			●	●	●	●
	Average voltage : V <sub>avg</sub> = (Va(Vab) + Vb(Vbc) + Vc(Vca))/3			●	●		
	Unbalance rate : V <sub>unbal</sub> (%) = (Vmax - V <sub>avg</sub> )/V <sub>avg</sub>			●	●		
Frequency	Hz			●	●		●
Power	Active, Reactive, Apparent Power (total, for each phase)			●	●	▲ (Total)	▲ (Total)
Power factor	Power Factor (total, each phase)			●	●		▲ (Total)
Power quantity	Forward/reverse valid and invalid, apparent power quantity			●	●	▲ (Forward Yes/No, Apparent)	●
Demand (Previous, Max)	Current (Ia, Ib, Ic)		●	●	●		▲ (Max)
	Electric power (effective, invalid, apparent)			●	●		▲ (Max)
Power Quality	THDV : Total Harmonic Distortion V			●	●		●
	THDI : Total Harmonic Distortion I		●	●	●		●

### Measurement accuracy

- Reference standards : IEC 61557-12
- Current : Three phase equilibrium (0.2~0.4I<sub>n</sub> : ± 1.5%, 0.4~1.2I<sub>n</sub> : ± 1.0%), single phase (0.2~1.2I<sub>n</sub> : ± 2.0%)
- Voltage : ±0.5%
- Power and power quantity : Class 2

Type	Error range	Error	
Power/Electricity	PF 1.0	0.2~0.4I <sub>n</sub>	±2.5%
		0.4~1.2I <sub>n</sub>	±2.0%
	PF 0.5 PF 0.8	0.4~0.8I <sub>n</sub>	±2.5%
		0.8~1.2I <sub>n</sub>	±2.0%

\*Note: Refer to the current measurement value of the LCD, etc. for poor internal current conduction (defect).

## ZSI function

The ZSI function is used to minimize the impact that MCCB and other electrical devices receive under accident conditions by reducing the delay time that the device eliminates the failure.

- 1) While a short time or ground fault occurs in a system where ZSI is set, the device at the point of failure generates a ZSI signal output to suppress the operation of the host device.
- 2) The MCCB at the point of failure is performed immediately and with minimum operating time without time delay to eliminate the fault.
- 3) The upper circuit breaker that receives the ZSI input signal operates according to the short time or ground operation delay time set for protection coordination on the system, but the upper circuit breaker that does not receive the ZSI input signal from the lower circuit breaker performs immediately without time delay in minimal operating time.

For normal ZSI operation, the operation time must be set properly for protection coordination so that the lower unit operates before the upper unit in case of short time relay/ground fault.

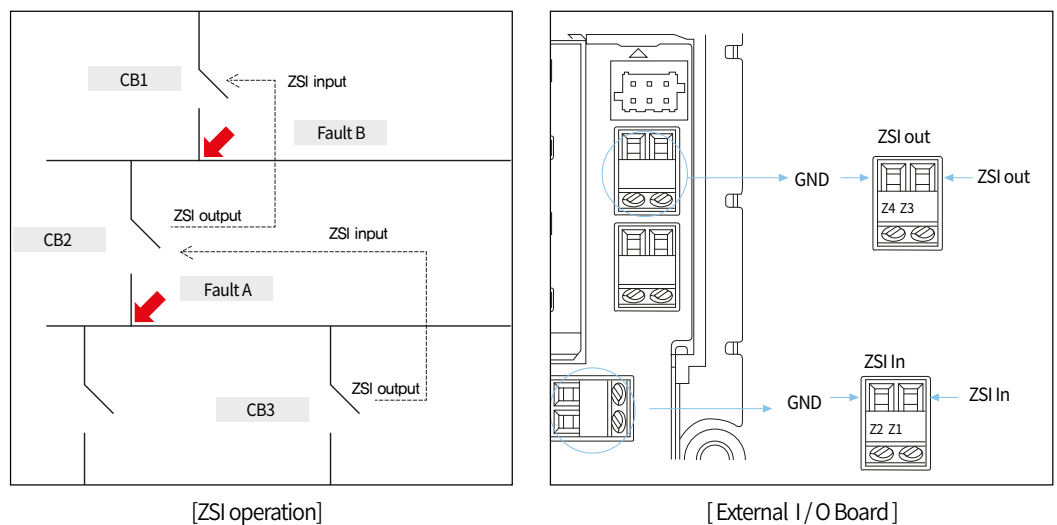

※Whether or not to use the ZSI function can be set in the ZSI PIN connection status and relay setting mode.  
 (ZSI used: ZSI pin removed, ZSI not used: ZSI pin fastened)  
 -When ZSI is set to enable, ZSI function operates.  
 -ZSI input signal is input to External I/O Board input terminal.

# Smart Trip Unit

---

## Smart Trip Unit - ETSi, ETMi, ETHi, ETLi (Electronic)

### Diagnosis and maintenance

Smart MCCB's ETU can save various operation contents such as device operation and setting change. It can also check its contents through communication and HMI.

#### Record

##### 1) System events

- Possible up to 50 records including the event type and time
- If the number exceeds
- 50, the oldest event is deleted sequentially (Roll-Over)

##### 2) Fault event

- When an accident occurs due to relay operation, up to 50 records including the type and time of occurrence is possible
- If the number exceeds • 50, the oldest event is deleted sequentially (Roll-Over)
- Accident waveform record: Records up to 2 accident waveforms (current and voltage waveform, 8 cycles)

##### 3) Max. Demand and Max. Power value

- Records occurrence value and occurrence time

##### 4) Device operation

- Operation/circuit breaker on (input) hour
- Circuit breaker/trip operation count
- Contact wear rate (%) : Wear rate according to the number of electrical openings and closings of the main body
- Load Profile : Hours of use according to the load used (hour)  
Classified into 4 levels (0~49% In, 50~79% In, 80~89% In, > 90% In)

#### Device management

ETU with communication function can obtain device information using communication.

- Communication related items (Communication address, speed etc.)
- Manufacturer
- Serial number
- Firmware version
- Model name, etc.



## Characteristic

			ETU Type				Display	
			ETSi	ETMi	ETHi	ETLi	ETU	3.5" HMI
Event record	System	Status change, setting change, system control, etc. Generated when an event occurs (up to 50) -Occurrence event type and occurrence time	—	●	●	●	—	●
	Fault	Accident (long time relay/short time relay/instantaneous/ground fault) Generated on occurrence (up to 50) -Accident type, accident value and occurrence time	—	●	●	●	—	●
Maximum value record	Demand (Occurrence value and time)	Ia, Ib, Ic	—	●	●	●	—	●
		Active/reactive/apparent power	—	—	●	●	—	●
	Power (Occurrence value and time)	Active/reactive/apparent power	—	—	●	●	▲ (Occurrence value)	—
Device operation	Operating time (hour)		—	●	●	●	—	●
	Circuit breaker on time (hour)		—	●	●	●	—	●
	Circuit breaker mechanical and electrical operation frequency (number of times)		—	●	●	●	—	●
	Circuit breaker electrical operation frequency (number of times)		—	●	●	●	—	●
	Trip count (number of times)		—	●	●	●	—	●
	Contact wear rate (%)		—	—	●	●	—	●
	Load profile		—	●	●	●	—	—

## Communication

### RS485 communication

- 1) Communication method : Modbus RTU
  - 2) Communication speed : 9,600, 19,200, 38,400 bps
  - 3) Communication distance : up to 5m (between devices), maximum number of connections is 16
  - 4) DC 24V power supplied from outside
  - 5) Slave address : 1 ~ 247
  - 6) Transmission information : device status and measured values, setting information, record data, etc.
- ※Communication is possible only when there is an external power supply (DC 24).

### Tester Port communication

- 1) External power supply (DC 12V) input
- 2) Connected devices : i-Tester, IPBM  
: Relay test current signal input

### BLE Communications

- 1) Distance possible for communication : 4m (Open space standard)
  - 2) Transmission information : Device status and measured values, setting information, record data, etc.
- ※Communication is possible only when there is an external power supply (DC 24).

\*When power is supplied to the device again, the device time is reset to 1 : 01 : 01 on January 1, 2018.

# Miniature Circuit Breakers

It satisfies IEC60947-2 and IEC60898-1 at the same time and can be applied to various industrial sites and residential spaces. It provides optimal solution through power measurement, on/off control, and wireless communication functions by using accessory devices for connectivity between low-voltage devices.





# E TAG & MCB

---

1. E TAG / E COLLECTOR .....	74
2. Miniature Circuit Breakers – Ultra-small breaker (BK63H) .....	76

---

# Miniature Circuit Breakers



E COLLECTOR



E TAG

## E TAG / E COLLECTOR

It is a device that performs power monitoring in a low voltage panel.

E TAG (Small sensing module) wirelessly transmits the measured power information to the E COLLECTOR.

E COLLECTOR provides power information to customers.

### Features

- **Power monitoring at the extreme end load**  
: Measurement of voltage/current/power, power quantity
- **Miniaturization design (suitable for panel)**  
: E TAG - tag structure (Installable form in MCB)  
: E COLLECTOR - Din Rail mounting structure
- **Wireless communication**  
: Minimizes installation space and provides installation convenience
- **Easy to collect power information**  
: One-gate information collection and operation in Smart LV panel

### Specification (E COLLECTOR)

Type	Details
Model name	IWM - ET - F24
Rated voltage	AC 110/220V, 50/60Hz
Number of connections for E TAG	20 or less recommended (up to 40)
LED	3 (Status, RF, Communication)
Protocol	Modbus RTU, Modbus TCP
Communication method	RS485, Ethernet, Wireless communication
Convergence time	Within 10 seconds
Mounting method	DIN-Rail
Size	72 (W) × 81 (H) × 65 (D), unit : mm
Weight	Approximately 200 g
Power Consumption	5W or less
Use temperature	-25 ~ +60 °C
Storage temperature	-40 ~ +80 °C

#### Wireless communication specifications

Type	Details	Remark
Wireless standard	IEEE 802.15.4	
Wireless output	0 dBm or less	
Frequency band	2.405MHz ~ 20480MHz	
Maximum number of sensors	40ea	Wireless communication cycle -20 or less : 5 seconds -21 or more : 10 seconds

### Specification (E TAG)

Type		1Pole	2Pole	3Pole	4Pole
Model name	32A	ISM - 11PB - 32A	ISM - 12PB - 32A	ISM - 33PB - 32A	ISM - 34PB - 32A
	63A	ISM - 11PB - 63A	ISM - 12PB - 63A	ISM - 33PB - 63A	ISM - 34PB - 63A
Number of poles		1P + N	1P + N	3P	3P + N
Rated voltage		220V	220V	380V	220V/380V
Rated current		32/ 64A			
Rated frequency		60Hz			
Measurement factor	Current	●	●	●	●
	Voltage	● Phase voltage	● Phase voltage	● Line voltage	● Phase/line voltage
	Power(quantity), power factor	●	●	●	●
Communication method		Wireless communication, 2.4GHz			
Combination method		Bottom attach			
Power consumption		2W or less			
Use temperature		-25 ~ +60 °C (Standard operating temperature : +23 °C)			
Storage temperature		-40 ~ +80 °C			
Humidity		Within 85% RH, no condensation			

### Exterior description

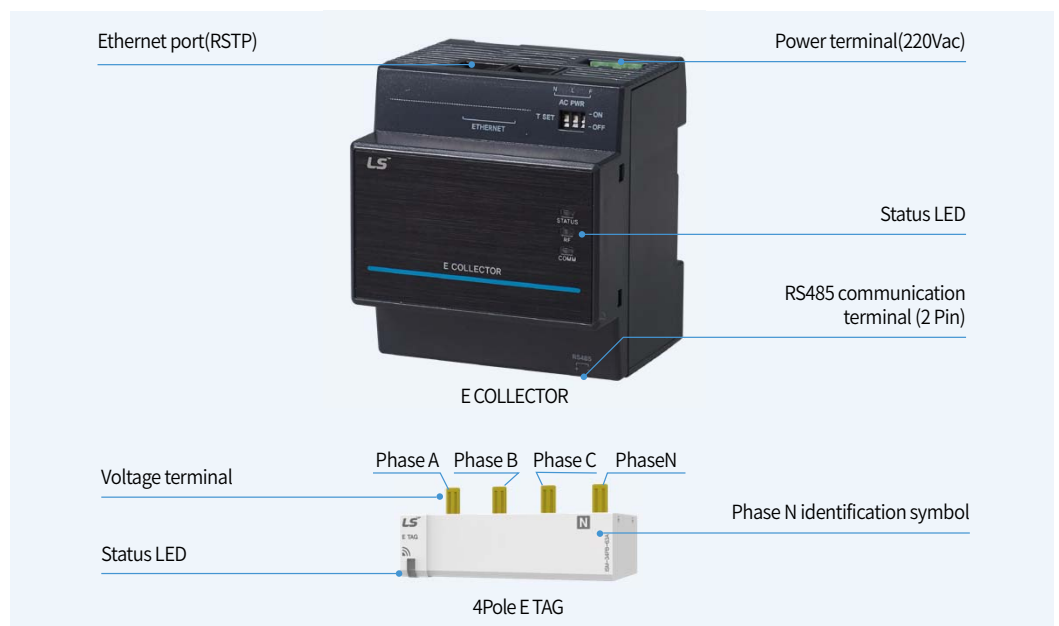

### Example of device usage

It is installed on the load side of the circuit breaker (MCB) to measure load power and provides power information wirelessly to the E COLLECTOR. E COLLECTOR provides the collected power information to customers through wired communication (RS485, Ethernet).



# Miniature Circuit Breakers

## Ultra-small circuit breaker (BK63H)



- Number of poles : 1P, 2P, 3P, 4P
- Rated current : 1 ~ 63A
- Rated breaking capacity : 10kA
- Instantaneous trip characteristics : B, C, D
- Protection function : Overload and short circuit current
- Status display and dual terminal application
- Accessories : AX, AL, SHT, UVT, OVT

### Specification



On/Off status display

Type			BK63H	
Frame size			63AF	
Number of poles			1P, 2P, 3P, 4P	
Rated current, In			1, 2, 3, 4, 6, 10, 16, 20, 25, 32, 40, 50, 63A	
Rated breaking current	Applicable standards	Voltage	1P	2P, 3P, 4P
		AC 415V	-	10kA
	IEC 60947-2, Icu	AC 240V	10kA	-
		Ics (= %Icu)	75%	75%
IEC 60898	AC 240/415V	10kA	10kA	
Rated voltage	AC	240V	240/415V	
	DC	60V	125V	
Rated insulation voltage (Ui)			AC 500V	
Rated impulse voltage (Uimp)			AC 6kV	
Rated frequency			50/60 Hz	
Instantaneous trip characteristics			B (4In), C (7.5In), D (12In)	
Protection function			Overload, short circuit current	
Endurance life	Electrical		10,000 times	
	Mechanical		20,000 times	
Protection grade			IP20	
Wire dimension and torque			18-4 AWG (0.75 ~ 25mm <sup>2</sup> ) 20 Kgf.cm	
Installation method			Using 35mm DIN rail	
Terminal structure			Lug/Screw dual structure	
Over current trip method			Thermal - Magnetic	
Ambient temperature			-25 ~ +55 °C (use)	
Certification status			CE, Safety certification (KC), SEMKO CB Classification : ABS, BV, DNV, GL, KR, LR, RINA	



# Smart LV Solution accessory device

The accessories of Smart LV Solution consist of devices with the latest IoT technology.

Each device performs functions of measurement, diagnosis, communication, control, monitoring and test to change the distribution panel and switchboard smartly.







# Smart LV Solution Accessory device

---

1. Gateway .....	80
2. Ethernet Converter .....	82
3. Thermal Imaging camera .....	84
4. M LINK .....	86
5. T Connection Module .....	88
6. Communication / power connection cable .....	89
7. i-Tester .....	90
8. Portable Battery & Trip Module .....	92
9. DC Power Module .....	93
10. Smart accessories .....	95
11. Sample composition .....	96

---

# Smart LV Solution Accessory device

## Gateway



Gateway is the communication device of Smart LV Solution.

Gateway is responsible for transmitting data from the serial-connected device using RS485 protocol to the LAN(Local Area Network) using TCP/IP.

Gateway provides its own web page, which allows you access the setting and status monitoring services for connected devices.

### Features

Type	Gateway web page
Settings screen	Device information can be checked and name and location information can be changed.
Thermal imaging monitoring	Provides thermal image monitoring device status, event, and trend information
RS485 (Channel1 & 2)	Displays the name and status of the device connected to the RS485 channel (provides detailed information when the device name is clicked)
Auto search	Provides RS485 automatic search function HMI connection function
General settings	Provides network, system and status information
Monitoring dashboard	Provides main status information of the connected devices (provides detailed information when the device name is clicked)

### Specification

Item	Details	Remarks
Rated voltage	DC24V (DC20.4~28.8V)	IEC60038 standard
Power consumption	Max. 12W	
Communication network	2×Terminal Block : RS485 2Ch 1×RJ45 : 1000 Ethernet 1×RJ45 : 10/100 Ethernet 2×RJ45 : RSTP (10/100 Ethernet) 1×WiFi (including AP function)	
External interface	2×USB Type A port(Host) 1×USB Mini B port(Device) / For maintenance	
Memory	RAM : 1GB(DDR3) MRAM : 2MB Flash : 1GB	
Installation	DIN rail mounting	
Size (W×H×D)	108mm×80mm×66mm	6Pole
Button	• 1×Push Button • Hard Reset: Press the button for 5 seconds • Soft Reset: Press the button for 1 seconds	
Switch	1×Dip Switch RS-485 communication termination settings	
Battery	± 3°C or ±3% or Reading (+10 to 100°C @ 20°C ±10°C amb)	
Operating environment	• Operating temperature: -25°C ~ 70°C (WiFi module: 0 ~ 50 °C) • Storage temperature: -40°C ~ 85°C (WiFi module: -20 ~ 80 °C) • IP rating: IP2X • Operating humidity: Max. 95% RH (no condensation)	

Web service

- Provides device registration and monitoring functions
- Provides remote firmware upgrade function
- Provides wave viewer function

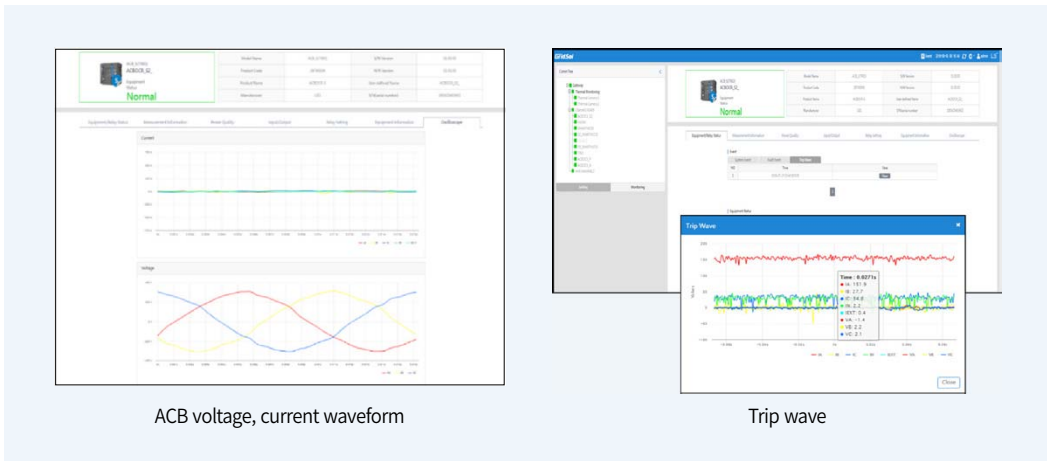

Exterior description



Target device

Circuit breaker	Susol ACB STU, Metasol ACB STU, Susol Smart MCCB
Measurement device	GIMAC1000, GIMAC-B, E TAG, MMP, DMPi, Energy Meter
Accessory device	M LINK, TRIO, Thermal CAM

# Smart LV Solution Accessory device



## Ethernet Converter

This device is installed on a low-voltage panel or distribution panel to collect data from serially connected RS485 communication devices and transmit it to a local area network (LAN) communication using TCP/IP. Control/status data and measurement values can be acquired by connecting to smart devices.

### Features

This module converts RS485 communication to Ethernet. By supporting a Ring network, it improves the reliability of communication. In case of an accident, it has functions of event push alarm(Mobile App.) and e-mail transmission to 5 registered users.

### Specification

Type	Details
Model name	Ethernet Converter
Rated voltage	DC24V ( $\pm 10\%$ )
Power consumption	1W or less
Function	<ul style="list-style-type: none"><li>• 1 PORT RS-485 (Modbus/RTU) communication support</li><li>• 2 PORT Ethernet (Modbus/TCP) communication support</li><li>• RSTP support</li><li>• Up to 8 Modbus Masters can be connected simultaneously</li><li>• Push alarm and E-mail transmission when an event occurs</li></ul>
LED	Power LED Comm. LED
Protocol	Modbus RTU, Modbus TCP
Communication method	RS485 to Ethernet
Port specification	RJ45, 2Port
Ethernet communication speed	10/100Mbps
Ethernet communication distance	Ethernet: up to 100m (single line), up to 50m (stranded line)
Type of dualization	RSTP (Rapid Spanning Tree Protocol)
Size	36 (W) × 81 (H) × 65 (D), unit : mm
Use temperature	-25 °C ~ +60 °C
Storage temperature	-30 °C ~ +70 °C
Ambient humidity	Within 85% RH, no condensation

Exterior description



Device usage example

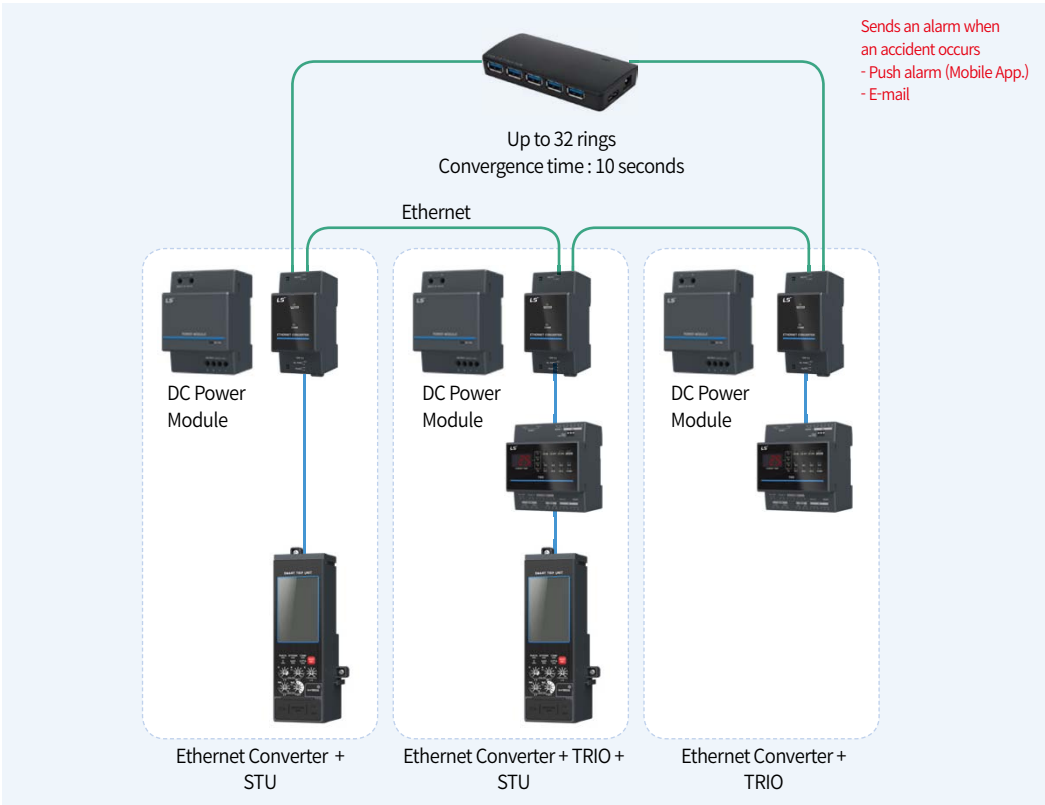

Target device

Circuit breaker	Susol ACB STU, Metasol ACB STU, Susol Smart MCCB
Accessory device	M LINK, TRIO

# Smart LV Solution Accessory device



## Thermal imaging camera

Thermal imaging cameras are installed inside switchboards, and with around-the-clock temperature monitoring of major facilities and cables, the user can prevent system and facility failures in advance and also reduce loss costs.

### Main features

The thermal imaging camera measures the degree of heat generation without contact or electrical connection to the measured object, and provides measurement results in the form of an image for a more intuitive understanding of the condition.

- Real-time monitoring of local switchgear heating, contact failure, and temperature change with non-contact infrared thermal imaging
- Accurate temperature measurement for target facilities with a 320×240 high-resolution sensor
- Ensuring sufficient monitoring coverage even inside narrow panels using the 89.9-degree wide-angle lens

### Product specifications

Item	Rating
Power	DC 12V
Interface	Gigabit Ethernet
Frame Rate	30 Hz
Time to First Image	< 10sec
Dimensions	58.6×39×118.6 mm
Weight	< 500g
Operation temperature	-15°C ~ 60°C
Scene temperature	-10°C ~ 150°C
Accuracy	± 3°C or ±3% or Reading (+10 to 100°C @ 20°C ±10°C amb)
Focus	Fixed

Exterior description

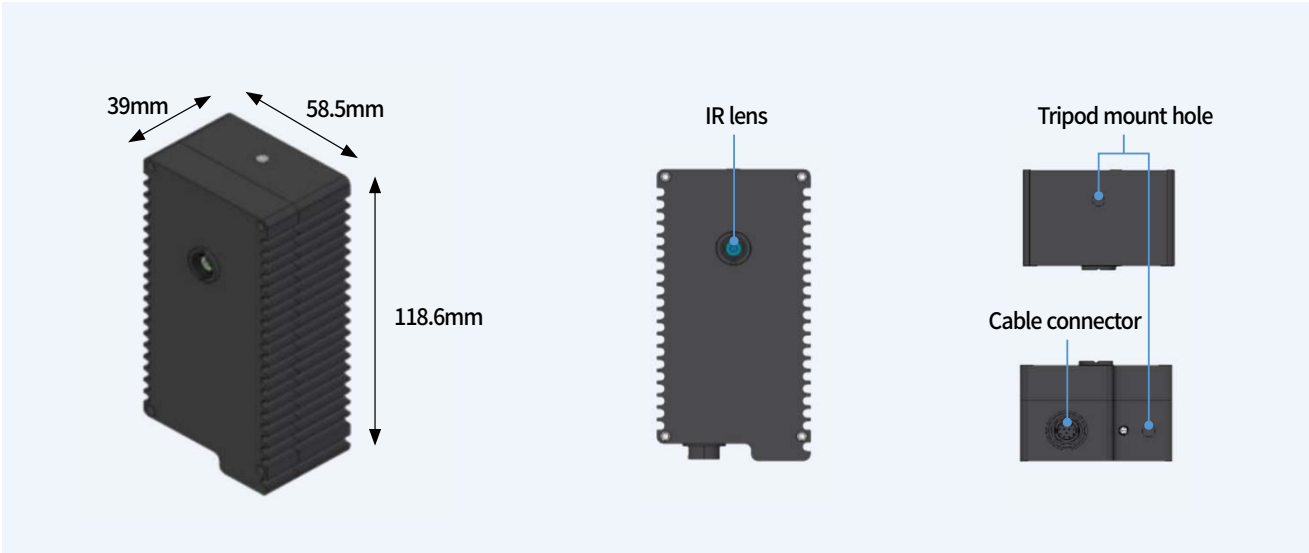

Product application examples

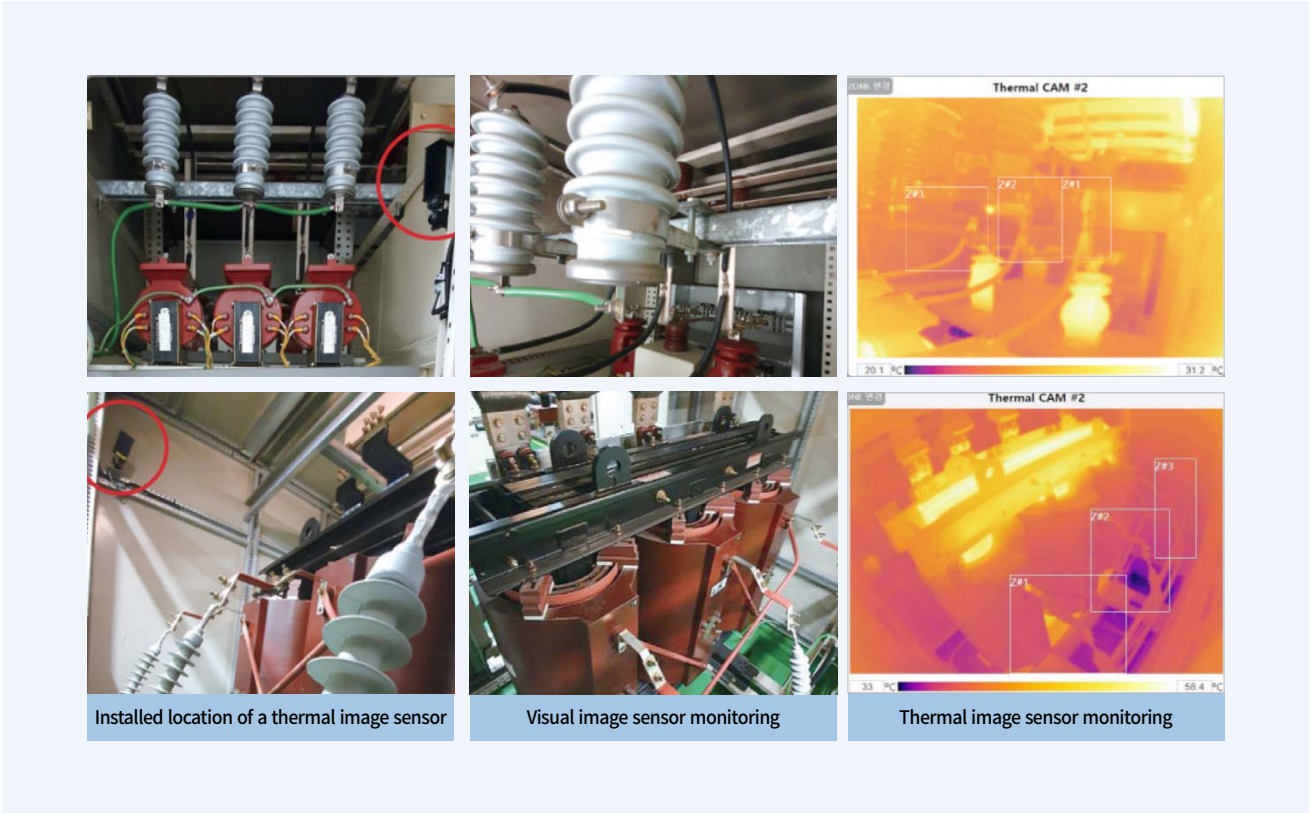

# Smart LV Solution Accessory device



## M LINK

It is a digital input/output and communication module for monitoring the status of on-site contacts, remote control of on-site contacts, and measuring on-site analog values on the low-voltage panel monitoring and control system.

### Features

Type		Details	
Model name		ILM - DC24V - DI6/DO4	
Rated voltage		DC24V (±10%)	
Power consumption		1.3W or less	
Function		Monitoring function : DI contact monitoring	
		Control function : DO contact control	
		Analog input value measurement : AI contact input value measurement	
		Communication function : RS485 (Modbus)	
Input/output contacts	DI	Number of contacts	6 (6 DI, COM.4) Note] COM contacts are the same in electrical circuit
		Connection method	Hardwired, pluggable
		Contact method	Dry contact
	DO	Number of contacts	4 (4 DO, 2 Com.)
		Connection method	Hardwired, pluggable
		Rated voltage/current	250Vac/3A, 30Vdc/3A
		Contact method	Non-Latch, A contact (Normal Open)
	AI	Number of contacts	1 (AI +, AI-)
		Connection method	Hardwired, pluggable
Input range		DC 4-20mA	
Protocol		Modbus RTU	
Communication method		RS485	
Size		54 (W) × 81 (H) × 65 (D), unit: mm	
Use temperature		-25 ~ +60 °C	
Storage temperature		-40 ~ +80 °C	
Ambient humidity		Within 85% RH, no condensation	



### Exterior description

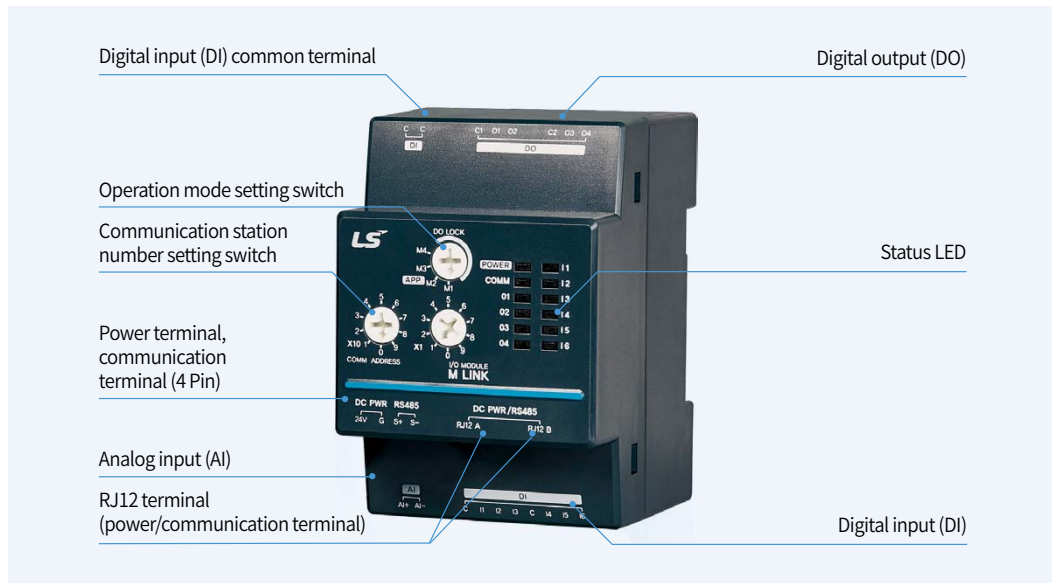

### Device usage example

It can be used a digital input/output (DI/DO) communication module for on/off/trip status monitoring and on/off control of the Circuit breaker (MCB/MCCB). It also provides DI/DO operation function according to the operation mode (M1~M4, DO LOCK) for user convenience.

Operation mode	Function and usage
M1	General DI/DO operation
M2	Remote circuit breaker control
M3	Remote/on-site circuit breaker control
M4	On-site load control (DI/DO linkage control)
DO Lock	General DI operation (DO cannot be controlled)

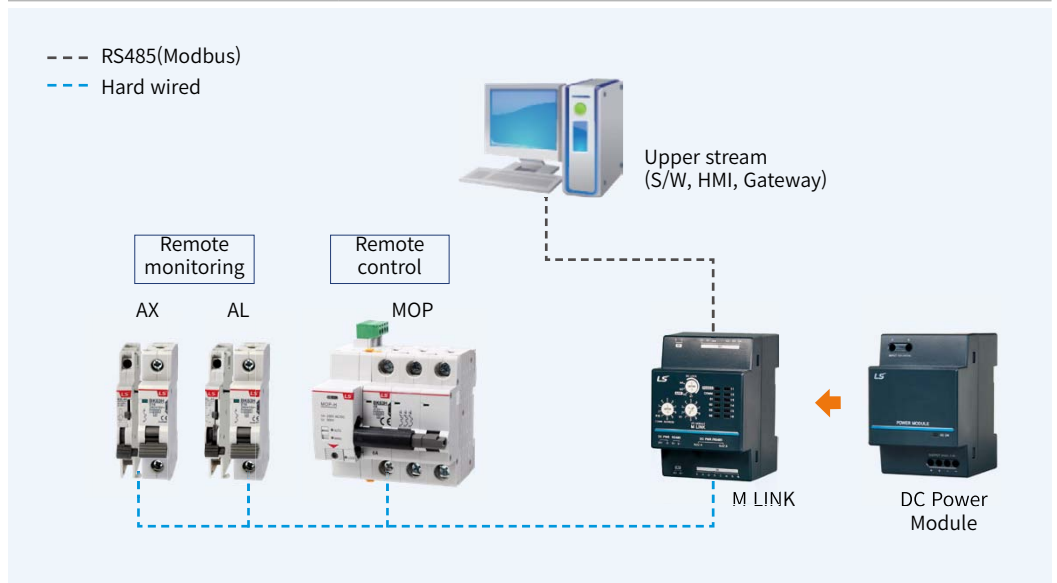

### Target device

Common device

# Smart LV Solution Accessory device



## T Connection Module

T Connection Module is a branch module that can provide convenience when connecting multiple RS485 communication devices through multi-drop communication. It also provides termination processing when the device is located at the end.

### Specification

Type	Details
Model name	ITCM
Rated voltage	DC24V ( $\pm 10\%$ )
Basic function	Multi-drop connection
	Termination Selection
Mounting method	DIN-Rail, Screw (Screw not supplied)
Size	17.8 (W) × 81 (H) × 65.6 (D), unit : mm

### Exterior description

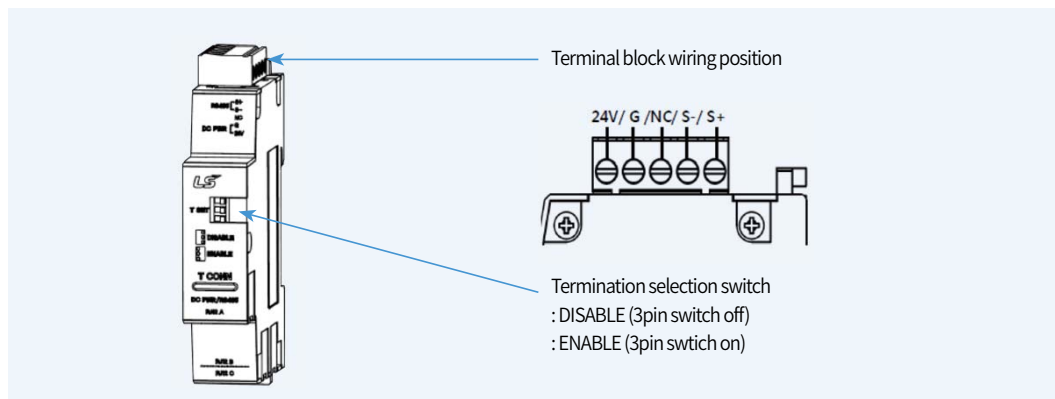

### Device usage example

When you wish to connect n number of devices excluding the upper system, you can conveniently configure them using n number of ITCM. Stable RS485 multi-drop is possible by deadening.

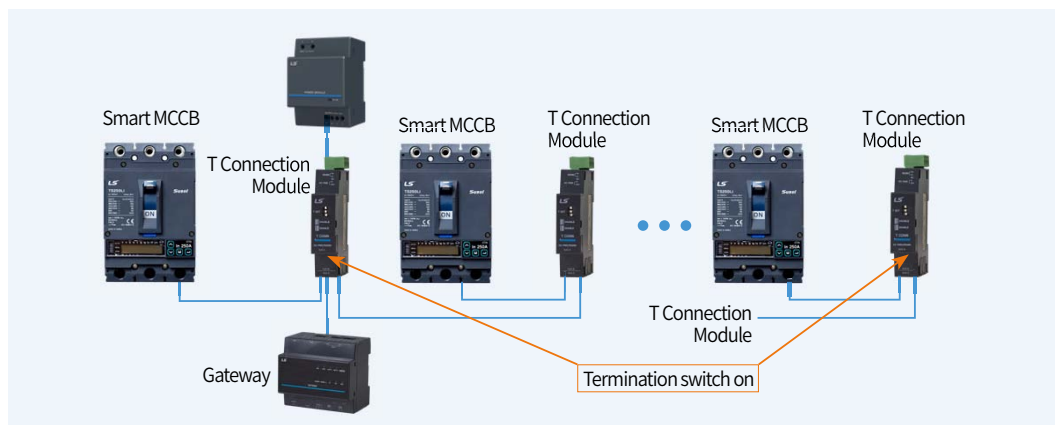

### Target device

Common device

## Communication / power connection cable

This is a communication / power connection cable used to connect Smart MCCB and T Connection Module, etc. There are three types : 0.35m, 1.3m, and 3m in length.

### Specification

Type	0.35m	1.3m	3m
Model name	EXIO L350	EXIO L1300	EXIO L3000
Basic function	Communication / power connection		

### Exterior description

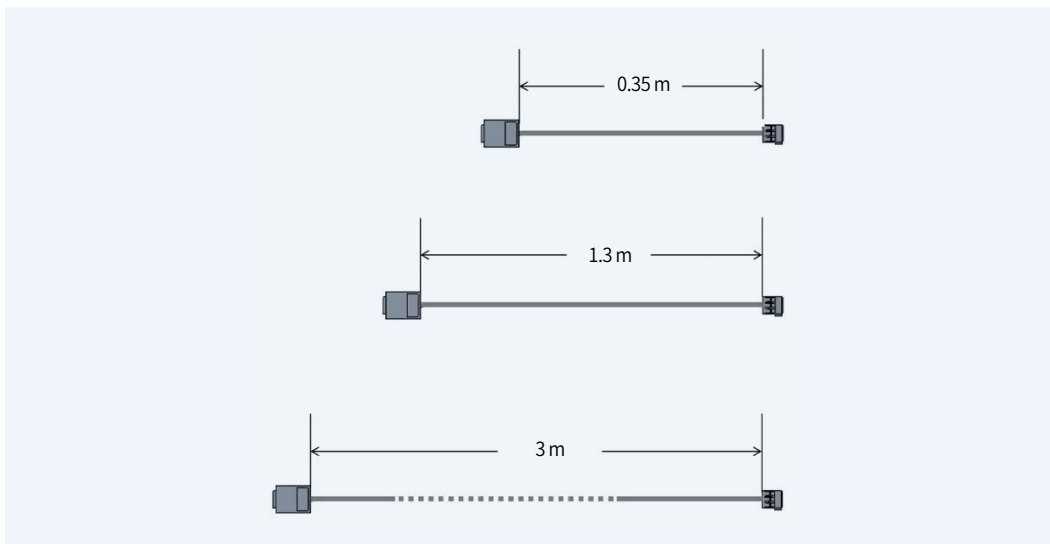

### Device usage example

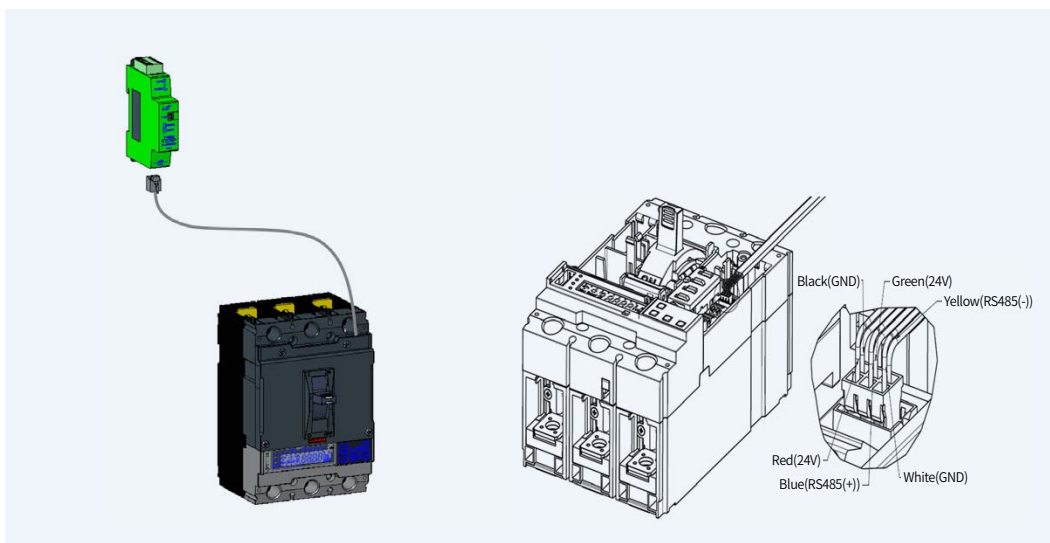

### Target device

Exclusive cable for Smart MCCB

# Smart LV Solution Accessory device



## i-Tester

The i-Tester (Intelligent Tester) is an accessory to test-drive ACB/MCCB. As a stand-alone type, it not only performs various relay tests such as manual/auto/user tests, but also has various functions such as self-calibration function, device information setting, relay setting, and device status checking. In addition, it supports 256 × 128 graphic LCD and supports not only English but also Chinese and Russian languages. It has the function to output the test and test results in the same way using the upper Manager S/W.

### Features

- **Calibration function**  
: The calibration function of i-Tester is used to calibrates the error using the output value set in i-Tester and the measurement current data.
- **Device H/W setting function**  
: It consists of the part to set the system configuration and time of the device and the part to set the language and time of the i-Tester itself.
- **Relay setting function**  
: It consists of the part to check the current relay element of the device and the part to set the relay.
- **Relay test**  
: As a part for testing the relay, it is composed of manual/automatic/user tests so that various relay tests can be conducted.
- **Control function**  
: It provides a function to clear or reset the device data and to control DO and CB.
- **System information**  
: It consists of the device information, relay status, and tester system information.
- **Test history**  
: It consists of a part to check the test history stored in i-Tester and a part to delete the saved history information.

### Specification

Type	Details
Model name	IPOT
Rated voltage	DC24V adapter, 9V alkaline battery 3EA, USB or rechargeable battery (10000mAh or more)
HMI	Graphic LCD module (256 × 128 Graphic LCD)
Supported language	English, Chinese, Russian
Key functions	<ul style="list-style-type: none"><li>• Device information checking function (information, DI, DO, self-diagnosis)</li><li>• Relay and H/W information setting function</li><li>• Device control and reset function</li><li>• Relay test function<ul style="list-style-type: none"><li>- Manual/auto/user test function</li></ul></li><li>• Test history storage (up to 255) and output (PDF) function</li></ul>
LCD composition	Navigation TREE configuration for all
Size	98 (W) × 210.5 (H) × 43.5 (D), unit : mm

Exterior description

Type	Details
① Power switch	Power On/Off function
② LCD	256 × 128 graphic LCD
③ KEY PAD	Menu navigation, setting and operation buttons
④ Adapter terminal	DC24V power input terminal
⑤ USB terminal	USB communication connection terminal (USB2.0)
⑥ Signal port	Signal terminals for device testing
⑦ Battery	Equipped with 9V alkaline batteries (× 3ea)

Device usage example



Target device

Circuit breaker	Smart ACB (STU), Susol/Metasol ACB (OCR), Smart MCCB, TS1600
-----------------	--

# Smart LV Solution Accessory device



## Portable Battery & Trip Module

It is a portable battery module that can power the Smart MCCB and test the trip function. The user can change and check the settings by applying power to the Smart MCCB while carrying this device, and easily check the trip function, which is the most important function.

### Specification

Type		Details
Model name		IPBM
Target device		Smart MCCB
Input power		AA size serial battery 2EA (battery specification : DC1.5V)
Output	Power supply	DC 12V ( $\pm 5\%$ )
	Trip signal	AC 0.9V, 60Hz ( $\pm 15\%$ )
Device operating time (battery replacement time)		More than 8 hours of continuous use ※The usage time can be changed depending on the battery capacity
Switch	Power supply	Slide switch, power supply On/Off
	Trip signal	Tact switch, Trip signal On/Off
LED	Power supply	Orange, DC 12V output status display
	Trip signal	Green, AC 0.9V Trip signal output status display
Size		72 (W) × 135 (H) × 34.5 (D), unit : mm

### Exterior description

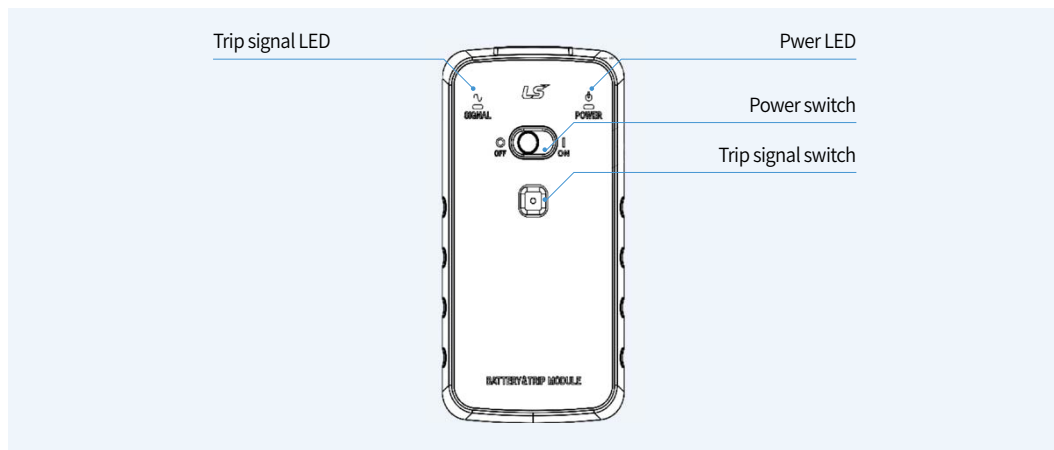

### Operation method

- 1) Check the power switch off status of the portable battery module.  
※If the battery is connected while the power switch is on, an error may occur in the device.
- 2) Open the battery cover on the back and install 2EA of AA size batteries.
- 3) Close the battery cover and connect the tester cable.
- 4) Open the glass cover of Smart MCCB and connect the Tester cable to the TEST port.  
※ If the direction of the tester cable does not match, an error may occur in the device.  
※ If the Tester cable is connected while the power switch is on, an error may occur in the device.
- 5) Operate the power switch of the portable battery module to On.  
- Check that the power is turned on to the Smart MCCB,  
and check and operate the Smart MCCB settings using the Smart MCCB key.  
- The Trip test of Smart MCCB can be performed using the Trip button of the portable battery module.
- 6) After using the portable battery module, operate the power switch to the Off status.



## DC Power Module

The DC Power Module is a power supply device that supplies DC24V. It is composed of 5 types according to the rated voltage of the input.

### Specification

Type	Specification				
Model name	IPM3P - AC240V /DC24V12W	IPM6P - DC30V /DC24V24W	IPM6P - DC125V /DC24V24W	IPM6P-AC415V /DC24V24W	IPM6P-ACDC240V /DC24V36W
Rated voltage	100 ~ 240Vac	24 ~ 30Vdc	48 ~ 125Vdc	380~415Vac	AC/DC100~240V
Input range	85 ~2 64Vac	20 ~3 3Vdc	40 ~ 138Vdc	323~457Vac	AC/DC95~264V
Frequency	50/60Hz	-		50/60Hz (45~65Hz)	DC or 50/60Hz(45~65Hz)
Output voltage	24Vdc (±5%)				
Output current	0.5A	1A			1.5A
Size (mm)	54 × 81 × 65	108 × 81 × 65			
Use temperature	-25 ~ +60 °C				
Storage temperature	-40 ~ +80 °C	-40 ~ +85 °C			
Mounting method	DIN-Rail, Screw (screws not included)				

### Exterior description

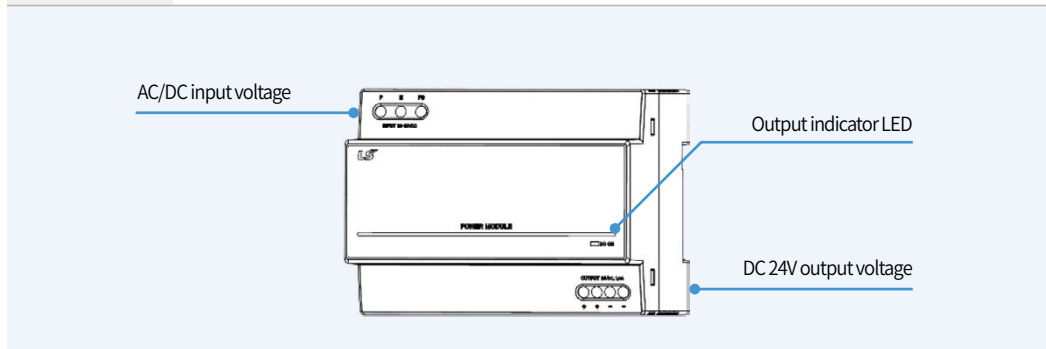

### Device combination

It can be used for the device that uses DC 24V as an input power supply and can be combined with Smart LV panel components. It can be combined with 12~36W DC Power Module.



# Smart LV Solution Accessory device

## DC Power Module

### Device usage example

#### 1) Composition of Smart MCCB + M LINK panel

- If Smart MCCB 6EA and M LINK 8EA are connected to 36W DC Power Module [ $11W+(6 \times 1W)+(8 \times 1.3W)=27.4W$ ], it can be used stably.



#### 2) Composition of ACB+Smart MCCB+M LINK panel

- If ACB 1EA, Smart MCCB 3EA, and M LINK 4EA are connected to 24W DC Power Module [ $11W+(3 \times 1W)+(4 \times 1.3W)=19.2W$ ], it can be used stably.



### Target device

Common device



## Composition of Smart accessory device

### Device composition by application

Accessory device	Function	Switchboard				Distribution board			
		Energy monitoring	Circuit breaker monitoring	Circuit breaker remote control	Power facility preventive diagnosis	Energy monitoring	Circuit breaker monitoring	Circuit breaker remote control	Power facility preventive diagnosis
Gateway / Ethernet Converter <sup>Note1</sup>		○ <sup>Note3</sup>	○ <sup>Note3</sup>	○ <sup>Note3</sup>	○ <sup>Note3</sup>		○ <sup>Note3</sup>	○ <sup>Note3</sup>	○ <sup>Note3</sup>
TRIO					○ <sup>Note4</sup>				
Thermal CAM					○				○
M LINK			○ <sup>Note5</sup>	○ <sup>Note5</sup>			○	○	
T Connection Module		○ <sup>Note6</sup>	○ <sup>Note6</sup>	○ <sup>Note6</sup>	○ <sup>Note6</sup>				
E TAG						○			
E COLLECTOR						○			
i-Tester / Portable Battery&Trip Module <sup>Note2</sup>					○				
DC Power Module		○	○	○	○		○	○	○

Note 1) Choose 1 from Gateway/Ethernet Converter

Note 2) Choose 1 from i-Tester/Portable Battery & Trip Module

Note 3) Gateway/Ethernet Converter is excluded from required installation devices when GridSol CARE host system is not used.

Note 4) TRIO is used with Smart ACB.

Note 5) M LINK is used with Smart MCCB.

Note 6) This accessory is used when communication expansion is required.

# Smart LV Solution Accessory device

## Sample composition

### Sample 1 : Energy monitoring

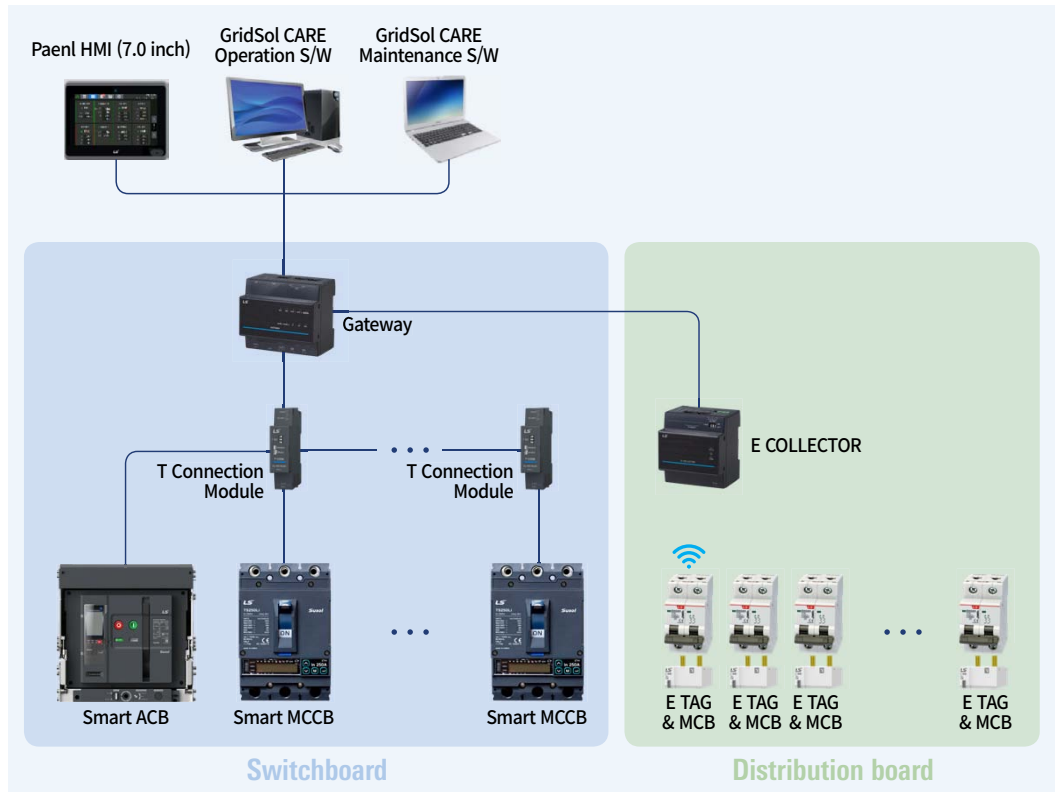

### Sample 2 : Circuit breaker status monitoring

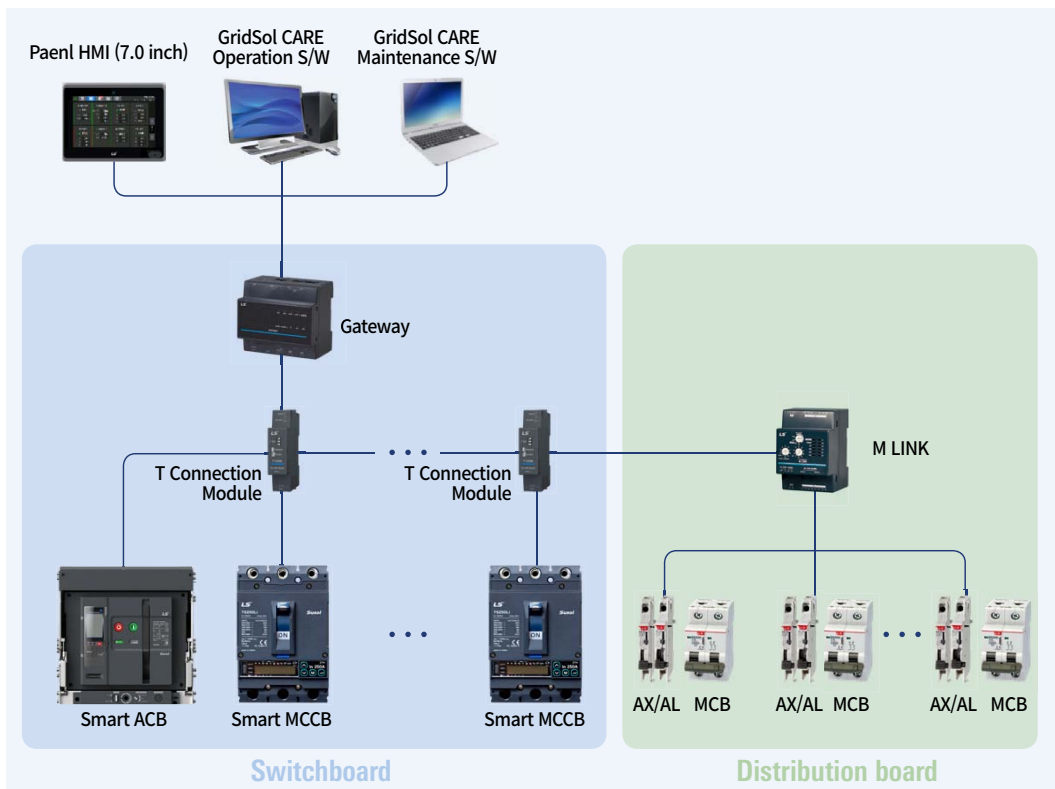

**Sample 3**  
: Circuit breaker  
remote control

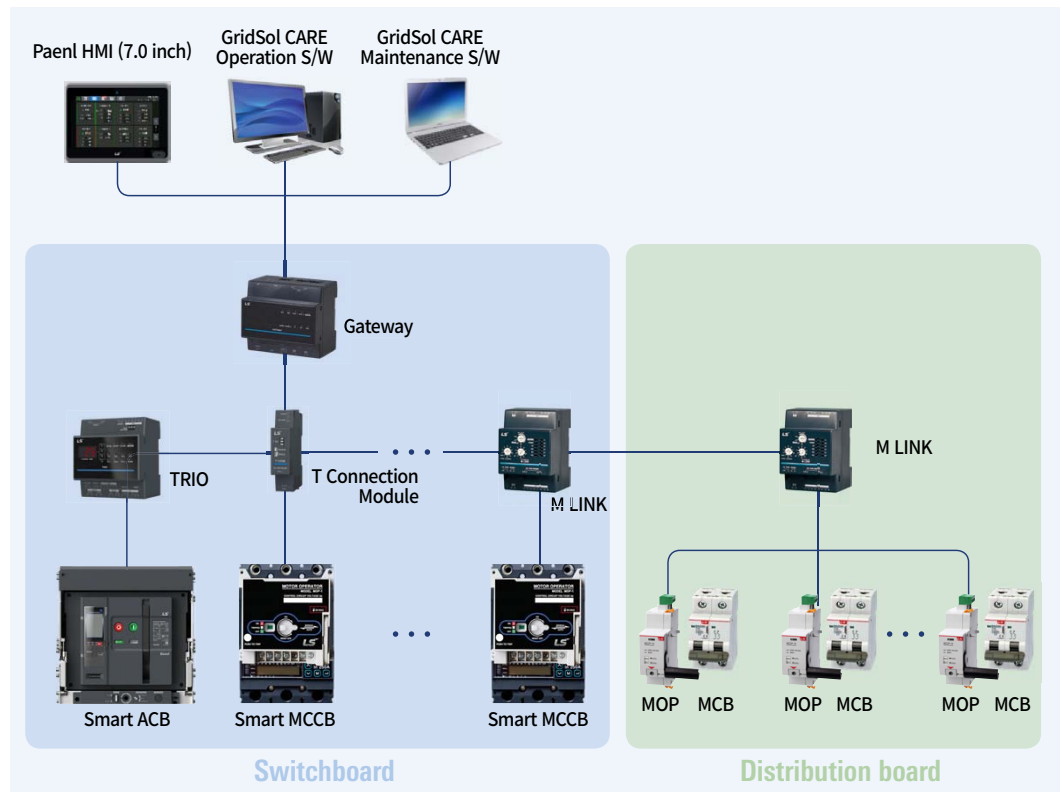

**Sample 4**  
: Prevention and  
diagnosis of power  
facilities

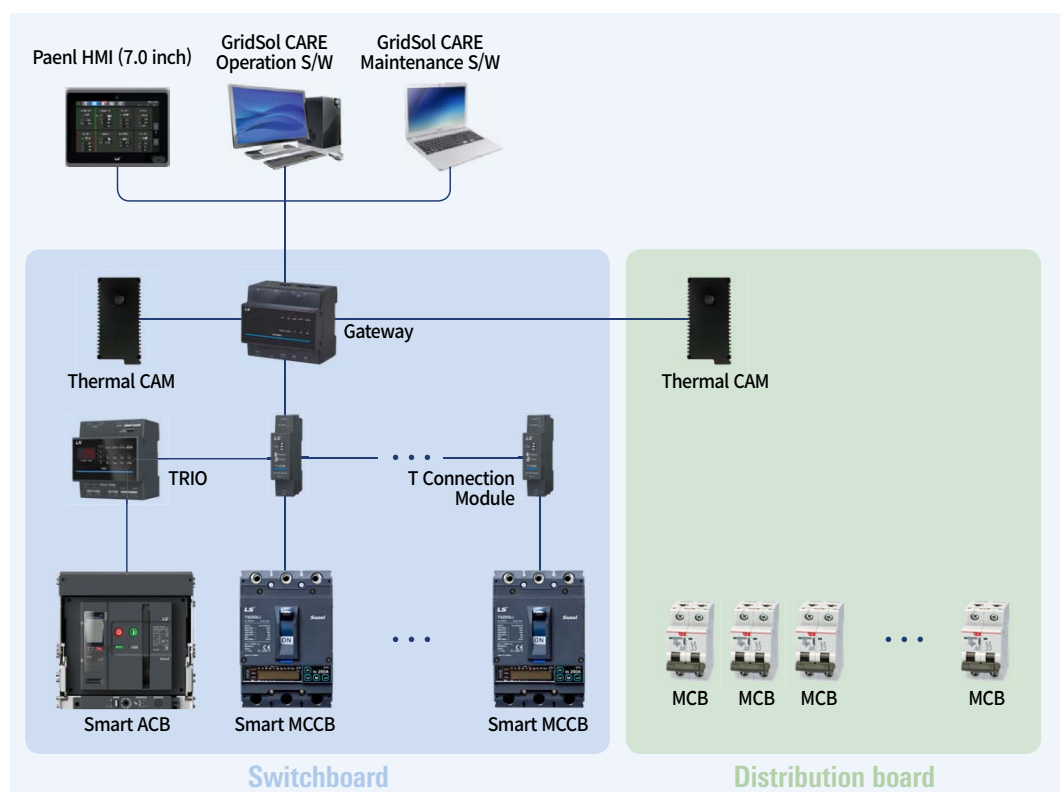

# Smart LV Solution upper system

Smart LV Solution upper system provides a variety of solutions for customers to conveniently manage their devices, systems, and energy information anytime, anywhere.

For convenience of on-site management, Panel HMI and Mobile App. are provided, and various S/W for remote monitoring/control is provided.





# Smart LV Solution Upper system

---

1. GridSol CARE Monitoring S/W (Cloud).....	100
2. GridSol CARE Operation S/W .....	102
3. GridSol CARE Maintenance S/W .....	104
4. Smart Viewer (Mobile App.) .....	105
5. Panel HMI (7.0 inch) .....	106

---

## GridSol CARE Monitoring S/W (Cloud)

GridSol CARE Monitoring SW provides real-time remote monitoring function to safely manage power facilities anytime, anywhere, and to operate them efficiently. It also provides event notifications and monthly reports through e-mail and SMS services.



### Features

- **Energy consumption monitoring by project and category (place, usage, day, time, etc.)**  
: Voltage, current, power, power demand, etc.
- **Power quality information monitoring by project and category (place, panel, device, etc.)**  
: Voltage, frequency, power factor, harmonics, etc.
- **Device self-diagnosis function**  
: Memory, Setting time, contact life, number of opening/closing, temperature overheating, Wiring status, battery, relay operation, etc.
- **Device lifespan prediction function**  
: Operating time, breaker On time, electrical/mechanical operation number, trip number, etc.
- **Temperature monitoring function**  
: Real-time monitoring of a specific point is possible through TRIO  
: Real-time monitoring of the area of interest is possible through Thermal CAM
- **When an event occurs, event recording and fault waveform data are provide**  
: Point information, phase angle analysis, harmonic analysis, effective value chart, etc.  
: E-mail, SMS transmission function support
- **Provide regular reports**  
: Energy consumption, power demand, power quality, diagnosis, alarm/event, etc..  
: E-mail transmission support for monthly reports

## Screen composition

- **Dashboard**  
: Energy consumption, estimated price, power quality, instantaneous power, weather information, project status are analyzed by category (location, use, time, day, week, month)
- **Monitoring & Control**  
: System/device monitoring, Hierarchy data
- **Diagnostics**  
: Energy diagnosis (total usage trend/comparison, usage/hourly usage)  
: Power quality diagnosis (voltage, frequency, power factor, THD/TDD)
- **Event**  
: Alarm, Event, Trip Wave
- **Customer support**  
: Customer center, Download center
- **Report**  
: Location, usage, usage by period, event, etc.
- **Common setting**  
: Theme setting (White, Dark), Language setting (Korean, English, Chinese), Personal information (Personal information, Electric charges)

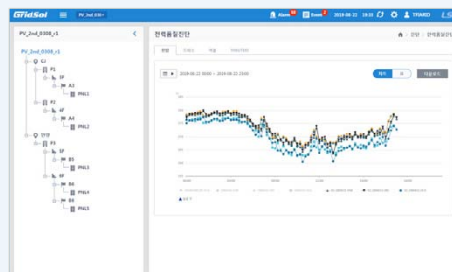

Power quality diagnosis

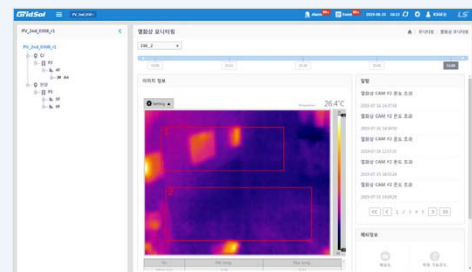

Thermal cam - track monitoring

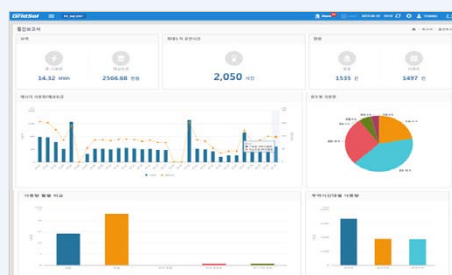

Monthly report

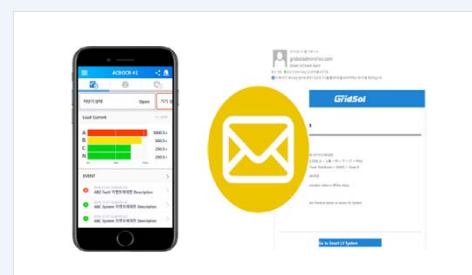

Send event alarm

## Target device

Communication device	Gateway, Ethernet Converter, E COLLECTOR
Accessory device	M LINK, TRIO, Thermal CAM
Circuit breaker	Susol ACB STU, Metasol ACB STU, Susol Smart MCCB
Measurement device	GIMAC1000, GIMAC-B, E TAG, MMP, DMPi, Energy Meter

## GridSol CARE Operation S/W

GridSol CARE Operation SW provides real-time remote monitoring and control functions to safely manage and efficiently operate power facilities connected to the same network



### Features

- **Monitoring energy usage by category (place, use, day of the week, time, etc.)**  
: Voltage, current, power quantity, power demand, etc.
- **Monitoring power quality information by category (place, panel, device, etc.)**  
: Voltage, frequency, power factor, harmonics, etc.
- **Device self-diagnosis function**  
: Memory, Setting time, contact life, number of opening/closing, temperature overheating, Wiring status, battery, relay operation, etc.
- **Device lifespan prediction function**  
: Operating time, breaker On time, electrical/mechanical operation number, trip number, etc.
- **Temperature monitoring function**  
: Real-time monitoring of a specific point is possible through TRIO  
: Real-time monitoring of the area of interest is possible through Thermal CAM
- **When an event occurs, event recording and fault waveform data are provided**  
: Event occurrence point information, phase angle analysis, harmonic analysis, effective value chart, etc.
- **Provides regular reports**  
: Energy consumption, power demand, power quality, diagnosis, alarm/event, etc.



## Screen composition

- **Dashboard**  
: Power consumption, power demand information, power device information, energy diagnosis information, energy prediction information, alarm/event, etc.
- **Monitoring & Control**  
: System and device monitoring and control, Hierarchy data
- **Diagnostic management**  
: Voltage PQ analysis, frequency PQ analysis, power factor PQ analysis, THD/TDD PQ analysis, total usage trend/comparison, demand diagnosis, etc.
- **History Management**  
: Alarm, Event, Trip Wave
- **Report**  
: Project, communication status, alarm/event, thermal image monitoring, statistics, diagnosis, system/device information, etc.
- **Common setting**  
: Theme setting (White, Dark), Language setting (Korean, English, Chinese)

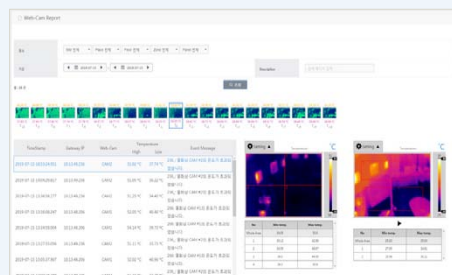

Real-time thermal imaging monitoring

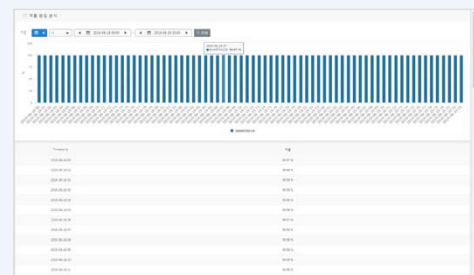

Power factor trend information

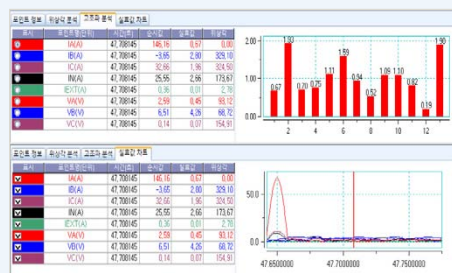

Failure waveform analysis information

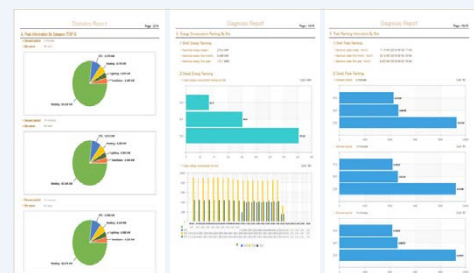

Regular report

## Target device

Communication device	Gateway, Ethernet Converter, E COLLECTOR
Accessory device	M LINK, TRIO, Thermal CAM
Circuit breaker	Susol ACB STU, Metasol ACB STU, Susol Smart MCCB
Measurement device	GIMAC1000, GIMAC-B, E TAG, MMP, DMPi, Energy Meter

# Upper system

## GridSol CARE Maintenance S/W

GridSol CARE Maintenance SW provides project and device management, remote monitoring and control functions, and testing functions for relay elements for each device.

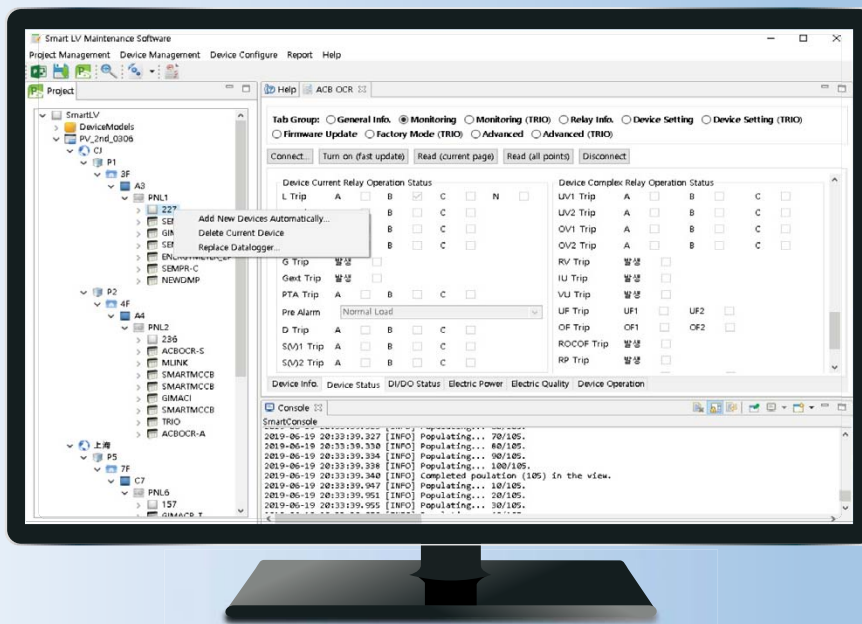

### Features

- **Project engineering function**
  - : Project creation, open, close, save, modify, remove, duplicate, user management, etc.
  - : Device information modeling and device data processing, replication, standard management by project
- **Device management, monitoring and control functions**
  - : Device search, device addition/deletion, representative device setting, purpose setting, etc.
  - : Data acquisition, firmware update, device setting, relay setting, control, etc.
- **Testing function for relay elements for each device**
  - : Available when using i-Tester
  - : Calibration, default test, manual test, scenario test
- **Report provided**
  - : Test result, project, communication status, data acquisition status, etc.

### Target device

Communication device	Gateway, Ethernet Converter, E COLLECTOR
Accessory device	M LINK, TRIO, Thermal CAM
Circuit breaker	Susol ACB STU, Metasol ACB STU, Susol Smart MCCB
Measurement device	GIMAC1000, GIMAC-B, E TAG, MMP, DMPI, Energy Meter

## Smart Viewer (Mobile App.)

Smart Viewer (Mobile App.) provides monitoring function of devices installed on the panel through short-range wireless communication function.



Smart Viewer



Smart MCCB



Smart ACB

### Features

- **Device and energy monitoring, failure analysis service**
  - Communication method : BLE (Bluetooth Low Energy)
  - Communication distance : Up to 4m
- **Event information of the device can be checked in the non-powered state.**
  - Communication method : NFC (Near Field Communication)
  - Communication distance : Up to 20mm
- **You can check the trip wave waveform stored in the device where the trip occurred.**
- **You can check the current and voltage waveforms of ACB.**
  - : STU S-type only.

### Target device

BLE	Susol ACB STU (S-type), Metasol ACB STU (S-type), Susol Smart MCCB ETU (ETLi)
NFC	Susol ACB STU (S-type), Metasol ACB STU (S-type)

# Upper system

## Panel HMI (7.0 inch)



### Specification

Model name	Rated voltage	Power consumption	Temperature range	
			Operation	Storage
IHM32	DC24V (±20%)	23.0W or less	0 ~ +50 °C	-20 ~ +60 °C

- Color TFT LCD (7.0" or more) + LED Backlight
- User operation : Touch pad
- Indication of device communication status
- Supports two languages (English and Chinese)
- Support upgrade function through USB port
- Sub-device connection through Ethernet communication
  - : Up to 32 sub-devices (up to 40 devices can be connected for E TAG)
  - : Up to 16 sub-devices can be selected and displayed (screen output)

### Display screen

- **Dashboard**
  - Full information display : Displays communication status with Gateway, Panel name, and system date/time
  - Quick View : Displays representative information of the device selected for monitoring in the form of icons
  - Alarm : Displays the alarm information of the device selected for monitoring in the form of a list
  - Event : Displays the event information of the device selected for monitoring in the form of a list
  - Setting : Gateway IP for communication linkage, device selection for monitoring, user password, etc.
- **Device Details**
  - Monitoring : Displays device status, communication status, measurement data, operation time, DI/DO status
  - Control : Performs device On/Off control
  - Management : Display and reset history and count data information
  - Event : Displays incident event, device operation and abnormal event
  - View setting : Displays device setting value and relay element setting value
  - Device information display : Displays device-specific information such as device ID and device name

### Target device

Communication device	Gateway, Ethernet Converter, E COLLECTOR
Accessory device	M LINK, TRIO, Thermal CAM
Circuit breaker	Susol ACB STU, Metasol ACB STU, Susol Smart MCCB
Measurement device	GIMAC1000, GIMAC-B, E TAG, MMP, DMPi, Energy Meter

### Screen description



Quick View, View All

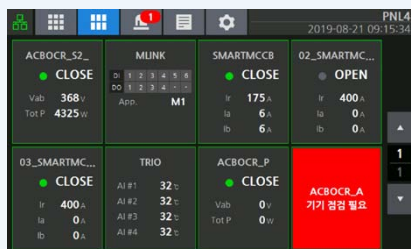

Quick View, View divided

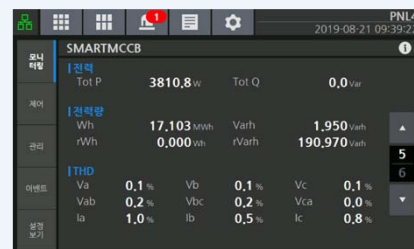

Detailed screen of device

Display form	Description
ACB STU	Displays device communication status, device name, and device status
TRIO	Displays device communication status, device name, and analog input point (AI #1) value
MCCB	Displays device communication status, device name, and device status
M LINK	Displays device communication status, device name, DI/DO status
MMP	Displays device communication status, device name, and device status
DMPi	Displays device communication status, device name, and measurement value

Display form	Description
ACB STU	Displays device communication status, device name, device status, value of Vab, Tot P
TRIO	Displays device communication status, device name, and analog input point (AI #1) value
MCCB	Displays device communication status, device name, device status, and values of Ia, Ib, and Ic
M LINK	Displays device communication status, device name, DI, DO, Mode status, control mode value
MMP	Displays device communication status, device name, device status, and values of Ia, Ib, and Ic
DMPi	Displays device communication status, device name, and values of Ia, Ib, and Ic

Display form	Description
Monitoring	Displays selected device monitoring data(Device status, communication status, measurement data, operation time, DI/DO status)
Control	Control command (device On/Off)
Management	Display and reset history and count data
Event	Event and alarm list display
Settings	Displays set value information, relay element set value
Device information	Displays device-specific information such as device ID and device name
Group	The category name of the individual information item
Label	Name of individual information item

### Exterior description

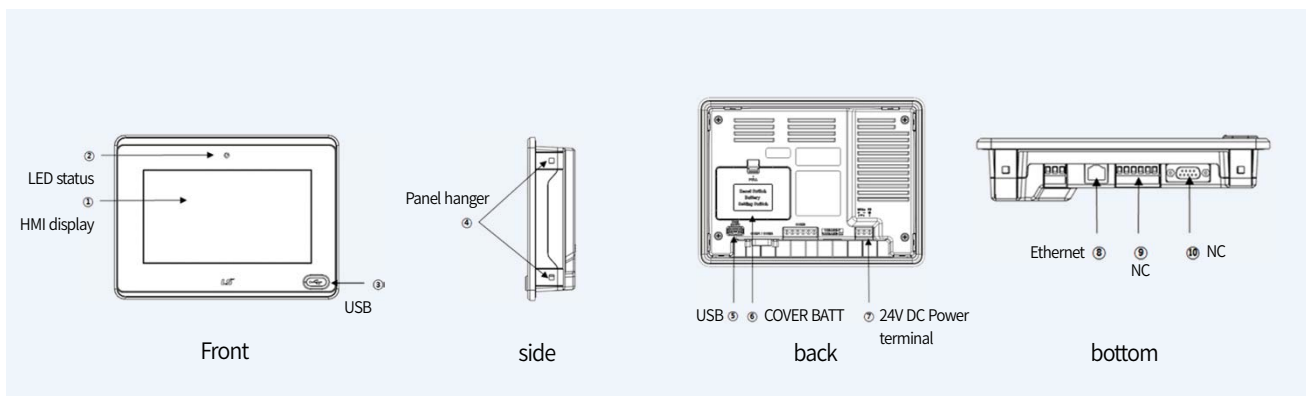

# Major Achievements

## Seoul National University, College of Engineering, Building 135 (Sep. 2019)

- Installed GridSol CARE Smart LV panel in Building 135, College of Engineering in Seoul National University on September 2019.
- Upper system : GridSol CARE Operation S/W, Panel HMI (7.0 inch), Smart Viewer (Mobile App.)
- Circuit breaker : Smart ACB, Metasol MCCB
- Measurement device : GIMAC-II Plus
- Communication device : Gateway, E COLLECTOR
- Accessory device : Thermal CAM, TRIO, DC Power Module, T Connection Module

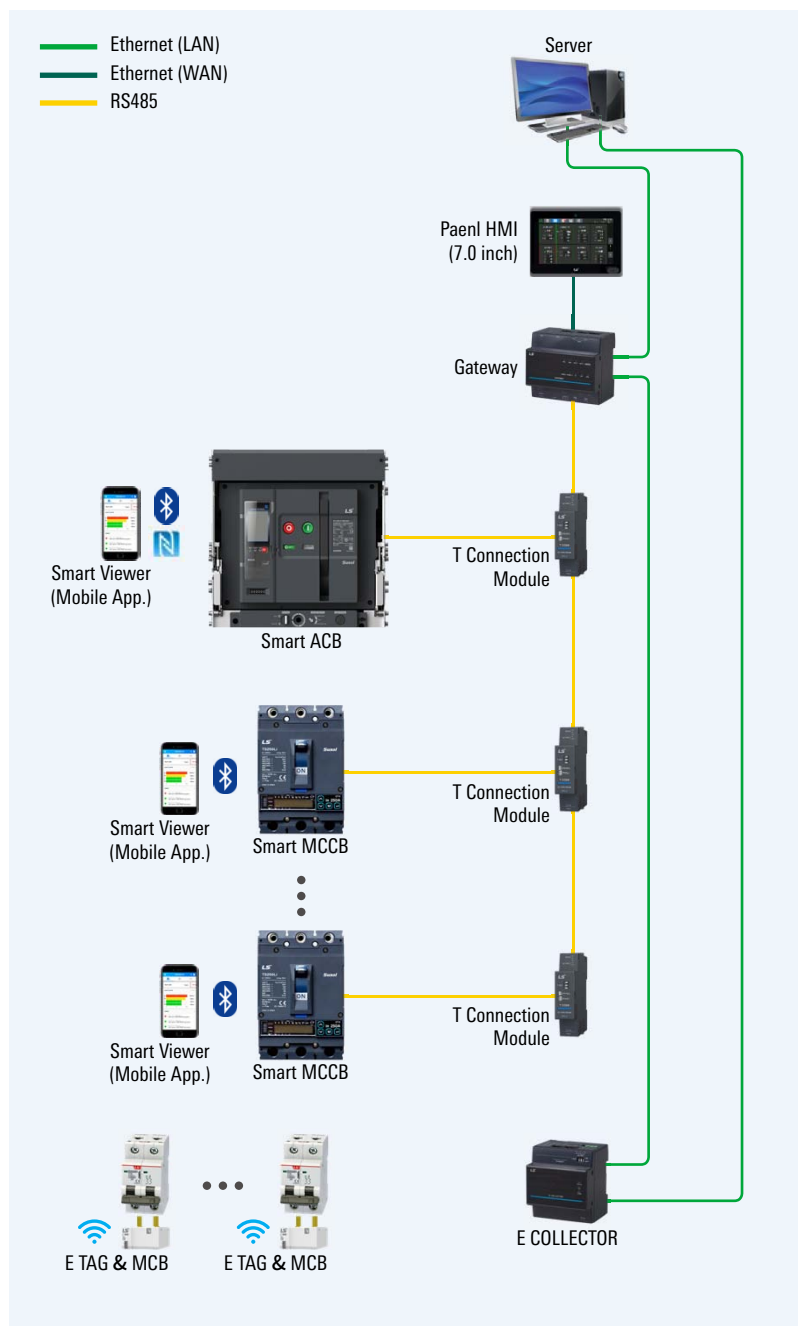

## KT Yongsan IDC Center Project (Nov. 2019)

- Applied in IDC Center of KT Yongsan on November 2019  
 With the addition of STU S Type's improved measurement accuracy (voltage/current : 0.5%) and the change function of A/B Group, TRIO and Panel HMI (7.0 inch) were used to configure the system without installing separate digital protection relay.
- Upper system : Server, Panel HMI (7.0 inch), Smart Viewer (Mobile App.)
- Circuit breaker : Smart ACB
- Communication device : Gateway
- Accessory device : TRIO, DC Power Module

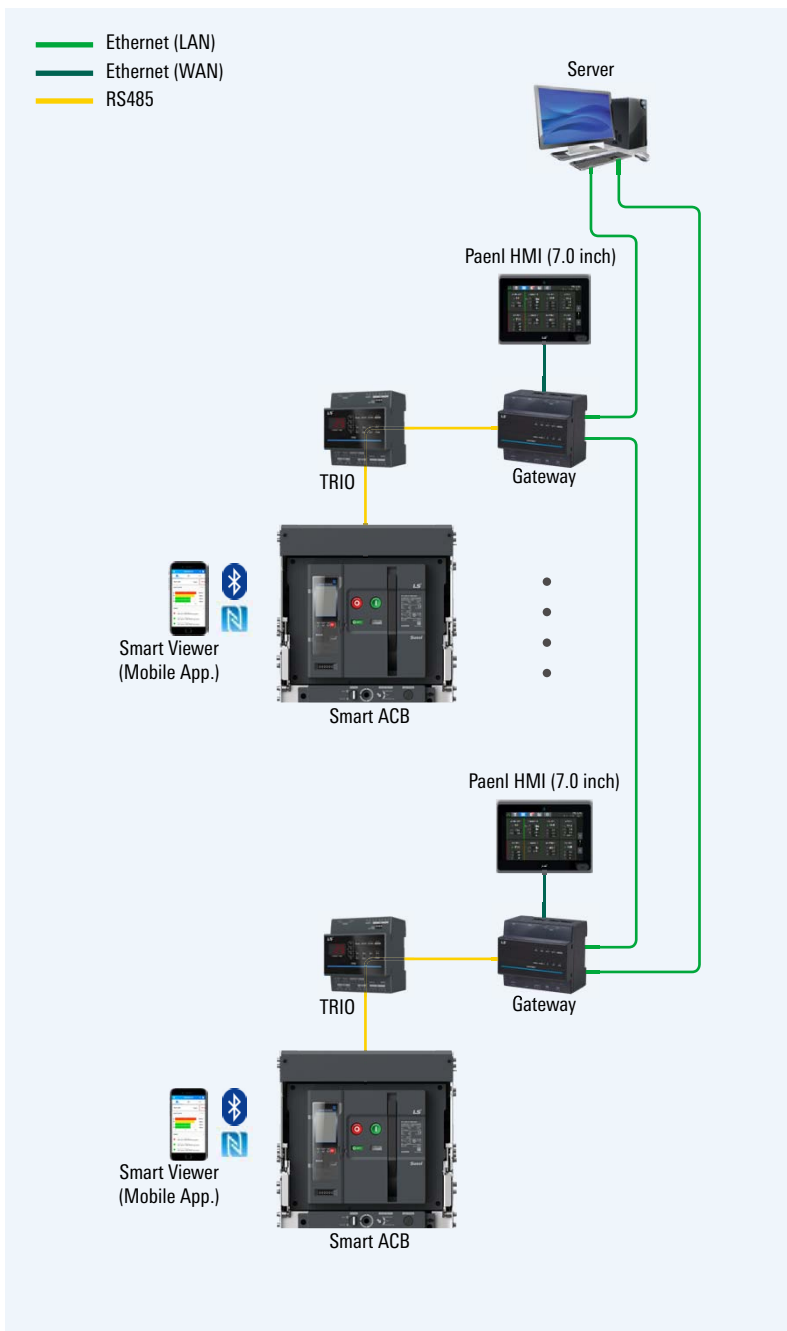

# Major Achievements

## LS ELECTRIC Cheongju 1 Work Site FEMS Station (Apr. 2020)

- Installed 7 GridSol CARE Smart LV Solution switchboards on FEMS Station of LS ELECTRIC Cheongju Work Site 1 on April 2020.
- Upper system : GridSol CARE Operation S/W, Panel HMI (7.0 inch), Smart Viewer (Mobile App.)
- Circuit breaker : Smart ACB, Smart MCCB
- Relay/Measurement device : XGIPAM, E TAG
- Communication device : Gateway, E COLLECTOR
- Accessory device : Thermal CAM, TRIO, M LINK, DC Power Module, T Connection Module

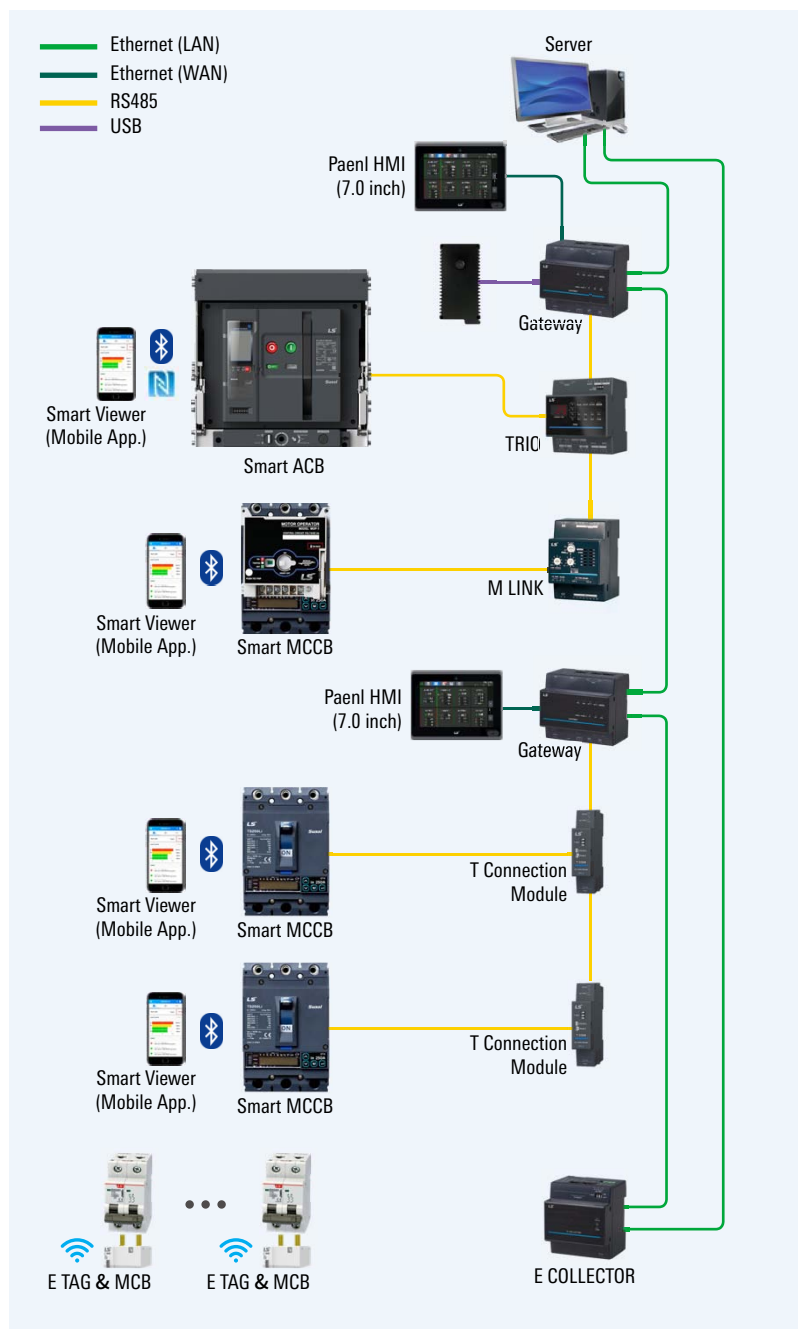





# Memo

---

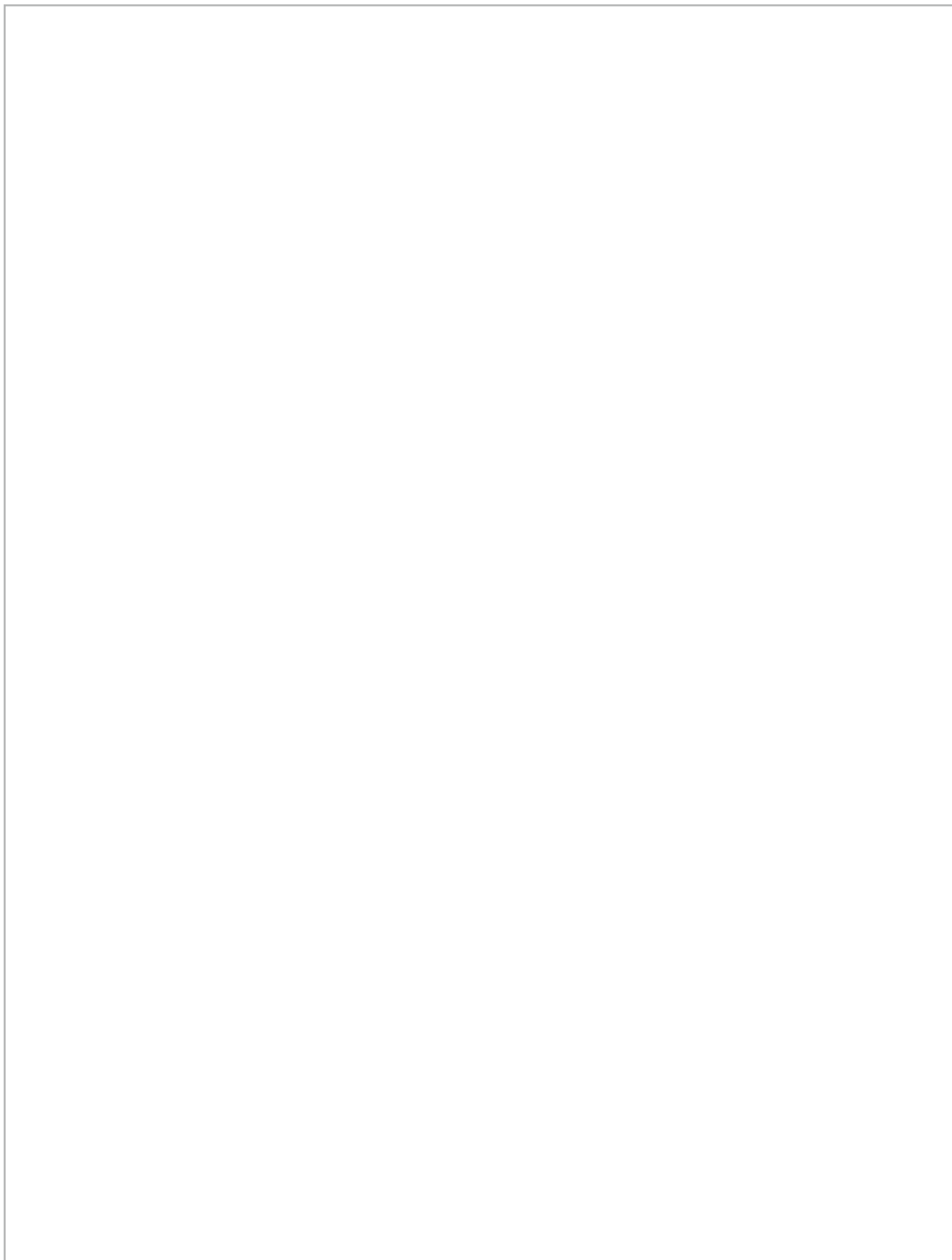



**Safety Instructions**

- For your safety, please read user's manual thoroughly before operating.
- Contact the nearest authorized service facility for examination, repair, or adjustment.
- Please contact qualified service technician when you need maintenance. Do not disassemble or repair by yourself!
- Any maintenance and inspection shall be performed by the personnel having expertise concerned.



- According to The WEEE Directive, please do not discard the device with your household waste.



[www.ls-electric.com](http://www.ls-electric.com)

■ **Headquarters**

127, LS-ro(hogye-dong) Dongan-gu, Anyang-si, Gyeonggi-Do, 14119, Korea

■ **Seoul Office**

LS Yongsan Tower, 92, Hangang-daero, Yongsan-gu, Seoul, 04386, Korea  
Tel: 82-2-2034-4916, 4684, 4429

■ **Overseas Subsidiaries**

- **LS ELECTRIC Japan Co., Ltd. (Tokyo, Japan)**  
Tel: 81-3-6268-8241 E-Mail: japan@ls-electric.com
- **LS ELECTRIC (Dalian) Co., Ltd. (Dalian, China)**  
Tel: 86-411-8730-5872 E-Mail: china.dalian@lselectric.com.cn
- **LS ELECTRIC (Wuxi) Co., Ltd. (Wuxi, China)**  
Tel: 86-510-6851-6666 E-Mail: china.wuxi@lselectric.com.cn
- **LS ELECTRIC Vietnam Co., Ltd. (Hanoi, Vietnam)**  
Tel: 84-222-2221-110 E-Mail: vietnam@ls-electric.com
- **LS ELECTRIC Middle East FZE (Dubai, U.A.E.)**  
Tel: 971-4-886-5360 E-Mail: middleeast@ls-electric.com
- **LS ELECTRIC Europe B.V. (Hoofddorp, Netherlands)**  
Tel: 31-20-654-1424 E-Mail: europartner@ls-electric.com
- **LS ELECTRIC America Inc. (Chicago, USA)**  
Tel: 1-800-891-2941 E-Mail: sales.us@lselectricamerica.com
- **LS ENERGY SOLUTIONS LLC (Charlotte, USA)**  
Tel: 1-704-587-4051 E-Mail: cmfeldman@ls-es.com
- **LS ELECTRIC Türkiye Co., Ltd. (Istanbul, Türkiye)**  
Tel: 90-212-806-1252 E-Mail: turkiye@ls-electric.com
- **LS ELECTRIC IBERIA S.L.U. (Madrid, Spain)**  
Tel: 34-910-28-02-74 E-Mail: iberia@ls-electric.com

■ **Overseas Branches**

- **LS ELECTRIC Tokyo Office (Japan)**  
Tel: 81-3-6268-8241 E-Mail: tokyo@ls-electric.com
- **LS ELECTRIC Beijing Office (China)**  
Tel: 86-10-5095-1631 E-Mail: china@lselectric.com.cn
- **LS ELECTRIC Shanghai Office (China)**  
Tel: 86-21-5237-9977 E-Mail: china@lselectric.com.cn
- **LS ELECTRIC Guangzhou Office (China)**  
Tel: 86-20-3818-2883 E-Mail: china@lselectric.com.cn
- **LS ELECTRIC Chengdu Office (China)**  
Tel: 86-28-8670-3201 E-Mail: china@lselectric.com.cn
- **LS ELECTRIC Qingdao Office (China)**  
Tel: 86-532-8501-2065 E-Mail: china@lselectric.com.cn
- **LS ELECTRIC Nanjing Office (China)**  
Tel: 86-25-8467-0005 E-Mail: china@lselectric.com.cn
- **LS ELECTRIC Bangkok Office (Thailand)**  
Tel: 66-90-950-9683 E-Mail: thailand@ls-electric.com
- **LS ELECTRIC Jakarta Office (Indonesia)**  
Tel: 62-21-2933-7614 E-Mail: indonesia@ls-electric.com
- **LS ELECTRIC Moscow Office (Russia)**  
Tel: 7-499-682-6130 E-Mail: info@lselectric-ru.com
- **LS ELECTRIC America Western Office (Irvine, USA)**  
Tel: 1-949-333-3140 E-Mail: america@ls-electric.com
- **LS ELECTRIC India Office (India)**  
Tel: 91-80-6142-9108 E-Mail: Info\_india@ls-electric.com
- **LS ELECTRIC Singapore Office (Singapore)**  
Tel: 65-6958-8162 E-Mail: singapore@ls-electric.com
- **LS ELECTRIC Italy Office (Italy)**  
Tel: 39-030-8081-833 E-Mail: italia@ls-electric.com