

Top 100
Global
Innovator
for 10 years

Susol

UL VCB

UL Vacuum Circuit Breakers



LS ELECTRIC

Features

LS Electric offers a full line-up of Susol VCBs with high interrupting capacity, large current (~50kA, ~3000A), and maximized compatibility with existing products through dual phases and compact design.





Susol *Super Solution*

Vacuum Circuit Breaker

Contents

• Overview	04
• External structure of VCB	08
• Overview of Susol VCB	10
• UVL Fixed type	11
• UVM Fixed type	19
• UVH Fixed type	29
• UVL Drawout type	41
• UVM Drawout type	53
• UVH Drawout type	75
• UVGT (Ground Truck)	129
• UCGT (Ground Truck)	135
• Accessories	154
• Circuit diagram for VCB control in remote	186
• Technical data	192

Susol VCB

The Vacuum Circuit Breaker (VCB) is installed on the medium voltage distribution line. In the case of abnormal current (overcurrent, short circuit, or ground fault), a separate external relay sends a signal to the vacuum interrupter located inside the circuit breaker to break the circuit to protect human life and load equipment.

Susol VCB responds.

- Customer needs for the breakers with high interrupting capacity and large current due to the integration and increase of the load capacity.
- Worldwide trend of diversification in the medium voltage distribution lines.
- Increase of the reliability for the temperature characteristics of circuit breakers.

Premium-type products to improve convenience and reliability of medium voltage switchgear configuration.

- Full line-up modeling to the high interrupting capacity and large current.
- Main structure with high reliability application.
- A variety of accessories and ability to maximize.

Suitable for use as the main circuit breaker to protect key installations in the places such as device industry, power plants, high-rise buildings, large ships.



▶ Full line-up of high/middle/low VCB models.

Voltage	Interrupting current	Rated current
4.76/15kV	25/31.5/40/50kA	1200/2000/3000/4000A
27kV	25/31.5/40kA	1200/2000/2500/2750A
38kV	31.5/40kA	1200/2000A

▶ Main circuit structure with high reliability.

- Maximized the durability and reliability of the main circuit contactors.
- Strong structure for the temperature rise (Natural cooling system).

▶ Convenience of switchgear configuration and a variety of accessories.



- CB compartment: Metal isolation is implemented to minimize damage and ensure safety. The convenience of switchgear design is achieved by its modular style.
- A variety of accessories: UVT, Plug Interlock, Key lock, Temperature Sensor, MOC, TOC.
- Maximizing compatibility with existing products through the dualistic deployment of phases and compact models.

※ Type testing is complete for all models according to latest standard, IEEE Std C37.09, IEEE Std C37.20.2, ANSI C37.54, ANSI C37.55

Rated voltage Isc[kA]	4.76/15kV				27kV			38kV	
	25	31.5	40	50	25	31.5	40	31.5	40
1200	UL certified	UL certified	UL certified	UL certified	ANSI type test	UL certified	UL certified	ANSI type test	ANSI type test
2000	UL certified	UL certified	UL certified	UL certified	Not developed	UL certified	UL certified	ANSI type test	ANSI type test
2500	Not developed	Not developed	Not developed	Not developed	UL certified	UL certified	UL certified	Not developed	Not developed
2750	Not developed	Not developed	Not developed	Not developed	UL certified	UL certified	UL certified	Not developed	Not developed
3000	UL certified	UL certified	UL certified	UL certified	Not developed	Not developed	Not developed	Not developed	Not developed
4000	UL certified	UL certified	UL certified	UL certified	Not developed	Not developed	Not developed	Not developed	Not developed

- : UL certified
- : ANSI type test
- : Not developed

Among the UL certified product

Fixed type	Draw-out type
	



CB Compartment

Convenience in building switchgears

- CB compartment structure: H type cradle
- Metal isolation is implemented to minimize damage and ensure safety
- Easy switchgear build



4.76/15/27/38kV 25/31.5/40/50kA

- Metal isolation is implemented to minimize damage and ensure safety.
- Convenience of operation by racking device in SWGR
 - Operator is able to withdraw CB without door open
 - Mechanically CB position indicator on the front side of SWGR
- Equipped with safety devices and accessories
 - Metallic shutter
 - Door interlock
 - Motorized racking system (4.76/15/27kV UVM/UVH Only)
 - Key lock on racking operation
 - Auto-connection of control wiring
- Convenience assembly of switchgear
 - Module structure enhance productivity



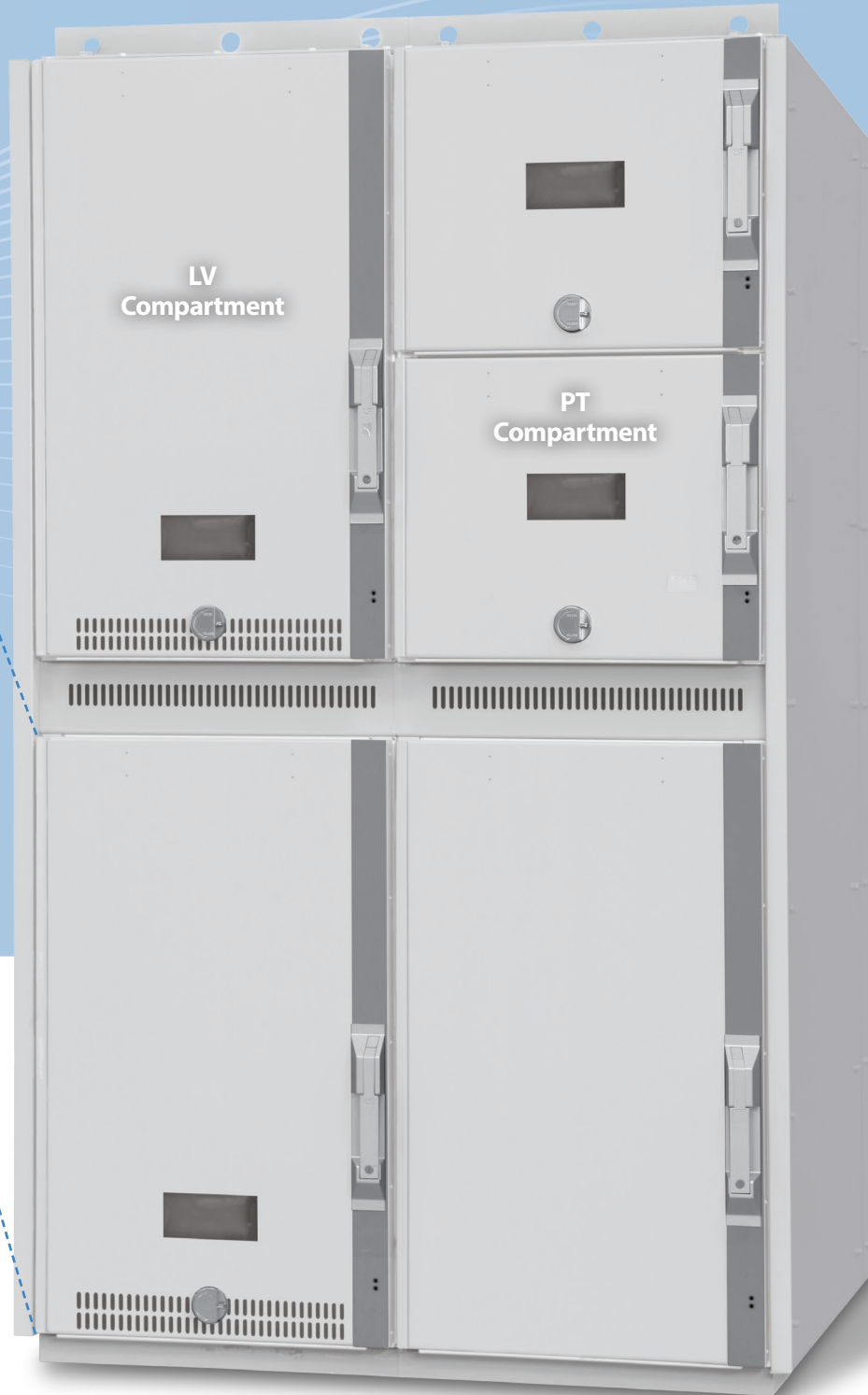

**Accessories of CB compartment
(H type cradle)**

- MOC (Mechanism Operated Cell S/W)
- TOC (Truck Operated Cell S/W)
- Shutter Padlock
- Key lock(Kirk-key applicable)

External structure of VCB

Breaker ... UVL/UVM type

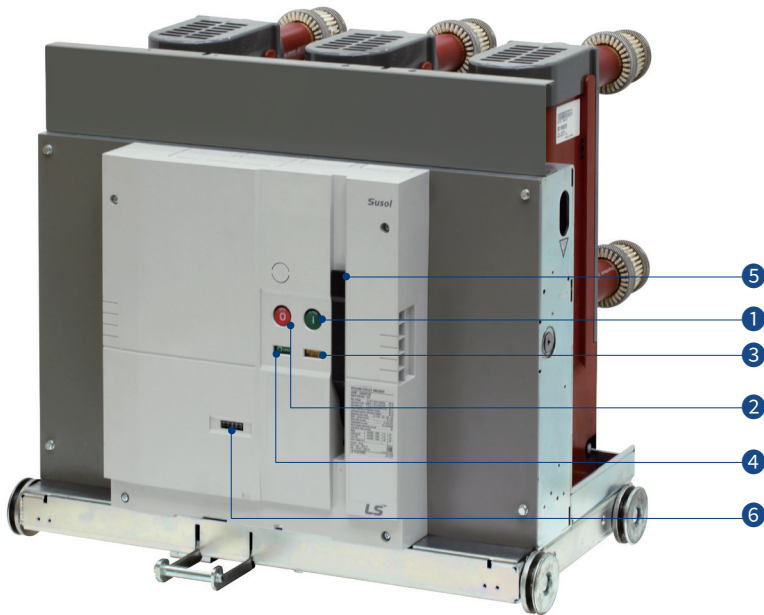

Name of each part

- ① CLOSE Button
- ② OPEN Button
- ③ Charge/Discharge Indicator
- ④ CLOSED/OPEN Indicator
- ⑤ Manual Charging Handle
- ⑥ Operation Counter

Back side



Breaker ... UVH type

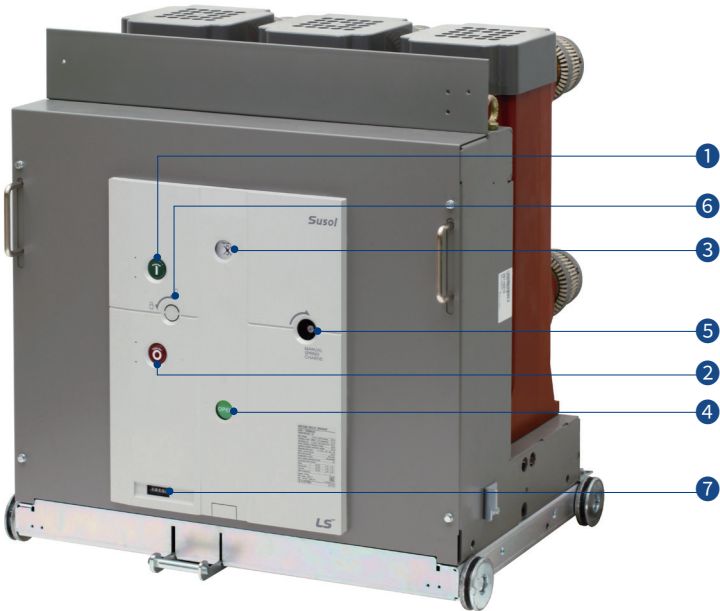

Name of each part

- ① CLOSE Button
- ② OPEN Button
- ③ Charge/Discharge Indicator
- ④ CLOSED/OPEN Indicator
- ⑤ Manual Charging Handle
- ⑥ Key Lock
- ⑦ Operation Counter

Back side





Overview of Susol VCB

Overview of VCB ratings

Rated voltage	4.76kV				15kV				27kV			38kV		
	I _r [A] \ I _{sc} [kA]	25	31.5	40	50	25	31.5	40	50	25	31.5	40	31.5	40
1200	UL certified	UL certified	UL certified	UL certified	UL certified	UL certified	UL certified	UL certified	UL certified	ANSI type test	UL certified	UL certified	ANSI type test	ANSI type test
2000	UL certified	UL certified	UL certified	UL certified	UL certified	UL certified	UL certified	UL certified	Not developed	UL certified	UL certified	UL certified	ANSI type test	ANSI type test
2500	Not developed	Not developed	Not developed	Not developed	Not developed	Not developed	Not developed	Not developed	UL certified	UL certified	UL certified	Not developed	Not developed	Not developed
2750	Not developed	Not developed	Not developed	Not developed	Not developed	Not developed	Not developed	Not developed	UL certified	UL certified	UL certified	Not developed	Not developed	Not developed
3000	UL certified	UL certified	UL certified	UL certified	UL certified	UL certified	UL certified	UL certified	Not developed	Not developed	Not developed	Not developed	Not developed	Not developed
4000	UL certified	UL certified	UL certified	UL certified	UL certified	UL certified	UL certified	UL certified	Not developed	Not developed	Not developed	Not developed	Not developed	Not developed

- : UVL/UVM-05/15 UL certified
- : UVM-27 ANSI type test
- : UVH-05/15 UL certified
- : UVH-27 UL certified
- : UVH-38 ANSI type test
- : Not developed

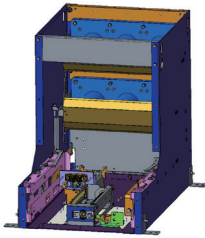
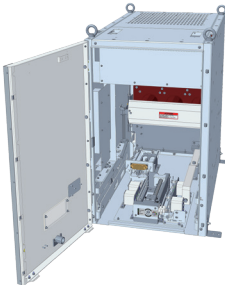
Overview of VCB and cradle configuration

Version	Fixed type	Drawout type (Draw in/out)		
Cradle	-	L	C	H
Appearance				
Applicable CB type	<ul style="list-style-type: none"> • UVL-05/15/27 • UVM-05/15 • UVH-05/15/38 	<ul style="list-style-type: none"> • UVM-05/15 • UVH-05/15/27 	<ul style="list-style-type: none"> • UVM-05/15 • UVH-05/15/27 	<ul style="list-style-type: none"> • UVL-05/15 • UVM-05/15 • UVH-05/15/38
Description	<ul style="list-style-type: none"> • Fixed type (No cradle, Fixed) 	<ul style="list-style-type: none"> • Economy Cradle for MCSG 	<ul style="list-style-type: none"> • Compact type CB Compartment *Shorter Depth than H-type 	<ul style="list-style-type: none"> • H type CB Compartment

Susol UVL

Fixed type



Contents

▪ Ratings and description	12
▪ Selection guide of circuit breaker type	14
▪ Order form	15
▪ Dimensions	16

Ratings and description

UVL type, Fixed type

UVL-05P / UVL-15P 

Circuit breaker type		UVL-05P				UVL-15P			
Rated voltage	Ur (kV)	4.76				15			
Rated withstand voltage	Power frequency (1min)	19				36			
	Lightening impulse (1.2×50µs)	60				95			
Rated short-circuit current	Isc (kA)	25	25	31.5	31.5	25	25	31.5	31.5
Rated normal current	Ir (A)	1200	2000	1200	2000	1200	2000	1200	2000
Rated frequency	fr (Hz)	50/60	50/60	50/60	50/60	50/60	50/60	50/60	50/60
Rated short-circuit making current	Ip (kA) at 60 Hz	65	65	81.9	81.9	65	65	81.9	81.9
Rated short-time withstand current	Ik (kA)	25	25	31.5	31.5	25	25	31.5	31.5
	3sec	●	●	●	●	●	●	●	●
Operating sequence	O - 0.3s - CO - 15s - CO	●	●	●	●	●	●	●	●

Technical data

Opening time		Less than 0.04 sec
Rated breaking time		3 Cycle
No-load closing time		Less than 0.06 sec
Type test class	Mechanical endurance	M2 (10,000)
	Electrical endurance	Reference standard (page 201)
	Capacitance current switching	C2
Operate temperature	Low	-40 °C
	High	40 °C

UVL-27P (ANSI Type Test)

Circuit breaker type		UVL-27P
Rated voltage	Ur (kV)	27
Rated withstand voltage	Power frequency (1min)	Ud (kV) 60
	Lightening impulse (1.2×50μs)	Up (kV) 125
Rated short-circuit current	Isc (kA)	25
Rated normal current	Ir (A)	1200
Rated frequency	fr (Hz)	50/60
Rated short-circuit making current	Ip (kA) at 60 Hz	65
Rated short-time withstand current	Ik (kA)	25
	3sec	●
Operating sequence	O - 0.3s - CO - 15s - CO	●

Technical data

Opening time		Less than 0.04 sec
Rated breaking time		3 Cycle
No-load closing time		Less than 0.07 sec
Type test class	Mechanical endurance	M2 (10,000)
	Electrical endurance	Reference standard (page 201)
	Apacitance current switching	C2
Operate temperature	Low	-40 °C
	High	40 °C

Selection guide of circuit breaker type

Description for circuit breaker type

UVL type, Fixed type

UVL	15	P	32	A	12
Basic model name	Rated voltage (kV)	Version	Interrupting current (kA)	Phase distance/Compatibility	Rated current (A)
UVL Susol VCB	05 4.76 15 15 27 27	P Fixed P Fixed	25 25 32 31.5 25 25	A 5.9"(150mm) C 10"(254mm)	12 1200A 20 2000A 12 1200A

Selection table of circuit breaker type

Ur [kV]	Isc [kA]	Ir [A]		Type of circuit breaker	Weight [kg]	Outline dimension H×W×D [mm]	Dimension page
		p = 150	p = 254				
4.76	25	1200		UVL-05P25A12	85	670×589×509	16
		2000		UVL-05P25A20	100	670×589×523.5	17
	31.5	1200		UVL-05P32A12	85	670×589×509	16
		2000		UVL-05P32A20	100	670×589×523.5	17
15	25	1200		UVL-15P25A12	85	670×589×509	16
		2000		UVL-15P25A20	100	670×589×523.5	17
	31.5	1200		UVL-15P32A12	85	670×589×509	16
		2000		UVL-15P32A20	100	670×589×523.5	17
27	25		1200	UVL-27P25C12	125	846.5×830×542.5	17

Full description for circuit breaker

UVL type, Fixed type

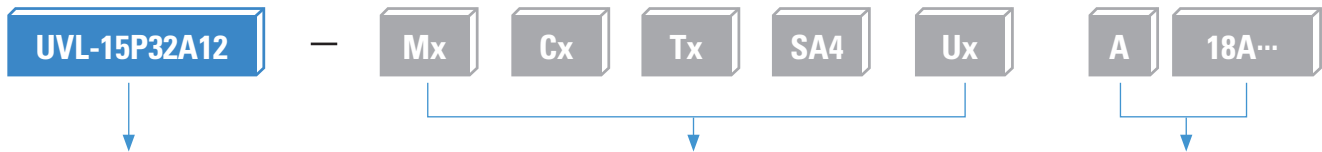

❶ Type of circuit breaker
(select from the previous page)

❷ Control source and auxiliary contacts & connector

❸ Accessories

※ In case of selecting ❸ Accessories, only type Symbol 'A' once. (ex. A18A)

Order form for circuit breaker

Please select only one of the items on the same horizontal line. (* Required selection)

UVL, VCB, Fixed type

(no extra charge extra charge)

❶ Type of VCB from selection table*

ea

❷ Control source

Motor* (Mx)								page 154
<input type="radio"/> M0	<input type="radio"/> M1	<input type="radio"/> M2	<input type="radio"/> M3	<input type="radio"/> M4	<input type="radio"/> M5	<input type="radio"/> M6	<input type="radio"/> M7	<input type="radio"/> M8
Without motor	DC 110V	DC 200V ~ 250V	DC 125V	DC 24V ~ 30V	DC 48V ~ 60V	AC 48V	AC 100V ~ 130V	AC 200V ~ 250V
Closing coil* (Cx)								page 155
<input type="radio"/> C0	<input type="radio"/> C1	<input type="radio"/> C2	<input type="radio"/> C3	<input type="radio"/> C4	<input type="radio"/> C5	<input type="radio"/> C6	<input type="radio"/> C7	<input type="radio"/> C8
Without CC	DC 110V	DC 200V ~ 250V	DC 125V	DC 24V ~ 30V	DC 48V ~ 60V	AC 48V	AC 100V ~ 130V	AC 200V ~ 250V
Shunt trip coil* (Tx)								page 156
<input type="radio"/> T0	<input type="radio"/> T1	<input type="radio"/> T2	<input type="radio"/> T3	<input type="radio"/> T4	<input type="radio"/> T5	<input type="radio"/> T6	<input type="radio"/> T7	<input type="radio"/> T8
Without SHT	DC 110V	DC 200V ~ 250V	DC 125V	DC 24V ~ 30V	DC 48V ~ 60V	AC 48V	AC 100V ~ 130V	AC 200V ~ 250V
Auxiliary contacts & Connector type*								page 159
<input type="radio"/> SA4 (10a10b Economic type, A-type)				<input type="radio"/> SQ4 (10a10b Standard, Q-type)				
Under voltage release (Ux)								page 160
<input type="radio"/> U0	<input type="checkbox"/> U1	<input type="checkbox"/> U2	<input type="checkbox"/> U3	<input type="checkbox"/> U4	<input type="checkbox"/> U5	<input type="checkbox"/> U6	<input type="checkbox"/> U7	<input type="checkbox"/> U8
Without UVT	DC 110V	DC 200V ~ 250V	DC 125V	DC 24V ~ 30V	DC 48V ~ 60V	AC 48V	AC 100V ~ 130V	AC 200V ~ 250V

※ Even without UVT, U0 must be selected to make VCB ordering code and description

Note) In case of DC24V control source(M4, C4, T4, U4), it is recommended to be used through Rated Control Voltage.

❸ Accessories

Combination table

U0	1	
U1-8		1
A1 & A2	1	

Available no. of Aux. contact

Symbol	10a10b
Standard	10 NO, 10 NC
with A1	9 NO, 9 NC
with A2	9 NO, 8 NC

Secondary shunt trip coil		page 157
<input type="checkbox"/> A1 (Secondary shunt trip coil)	<input type="checkbox"/> A2 (Secondary shunt trip coil monitoring contact)	
※ In case of selecting A1, maximum auxiliary contacts are 9a9b		※ In case of selecting A2, maximum auxiliary contacts are 9a8b
Keylock		page 162
<input type="checkbox"/> A7 (Keylock(Individual key))	<input type="checkbox"/> AG (Keylock(Same key))	
<input type="checkbox"/> AM (Kirk key, CAMLOCK type)	<input type="checkbox"/> AN (Kirk key, CN-22 type)	<input type="checkbox"/> AP (Kirk key, Double CAMLOCK type)
Button padlock		page 163
<input type="radio"/> A8 (Button padlock)	<input type="radio"/> AX (Button padlock In open)	
Lead wire*		page 164
<input type="radio"/> AA (Lead wire)		

Separately sold accessories

CTU (Coil test unit)

page 169

73873171221 CTU (Coil test unit)

CTD (Condenser trip device)

page 170

76113143001 CTD (Condenser trip device) AC/DC 100V, 110V
 76113143002 CTD (Condenser trip device) AC/DC 200V, 220V

UDC (UVT delay controller)

page 171

52773171282 UDC (UVT delay controller) AC/DC 100~130V
 52773171283 UDC (UVT delay controller) AC/DC 200~250V
 52773171281 UDC (UVT delay controller) DC 48~60V and AC 48V

Dimensions

4.76kV, 25/31.5kA, 1200A

UVL type, Fixed type

[Unit: inch(mm)]

Type of circuit breaker

- UVL-05P25A12
- UVL-05P32A12

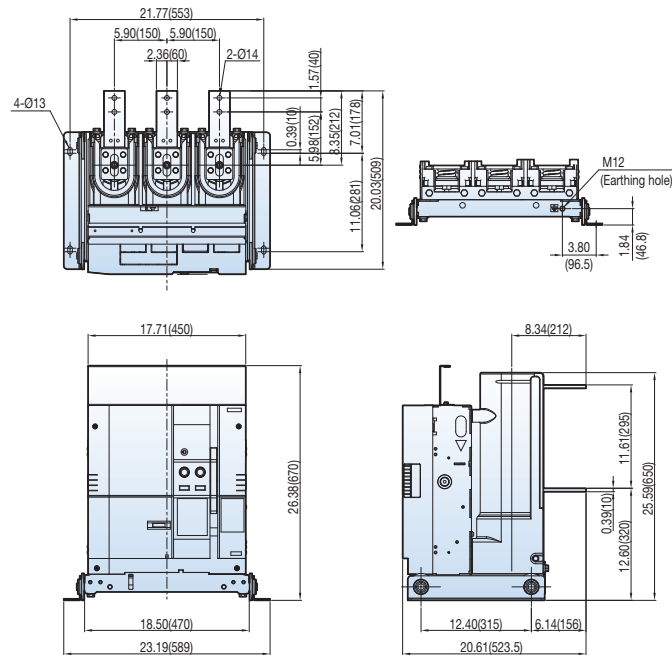

15kV, 25/31.5kA, 1200A

Type of circuit breaker

- UVL-15P25A12
- UVL-15P32A12

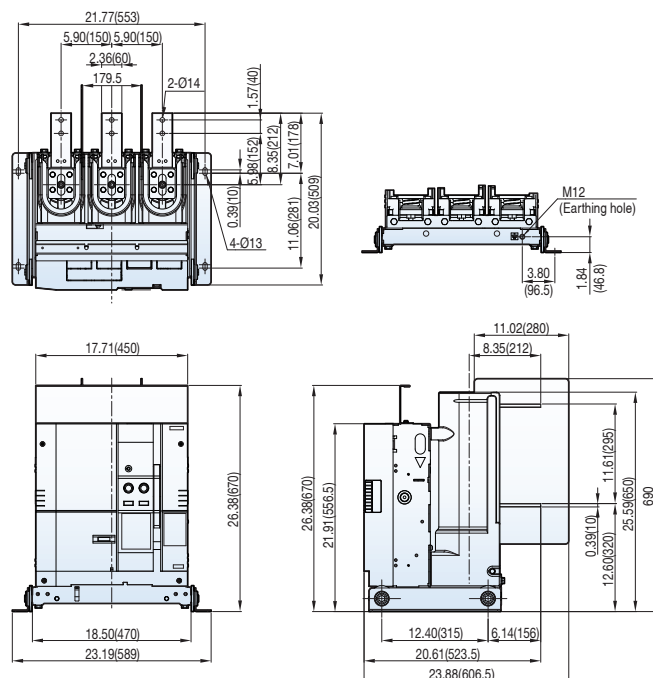

4.76/15kV, 25/31.5kA, 2000A

UVL type, Fixed type

Type of circuit breaker

- UVL-05P25A20
- UVL-05P32A20
- UVL-15P25A20
- UVL-15P32A20

[Unit: inch(mm)]

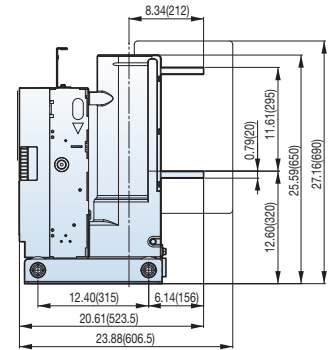
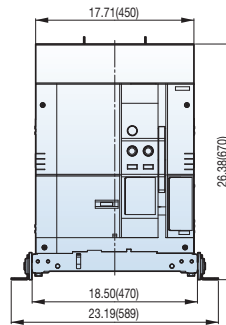
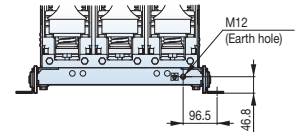
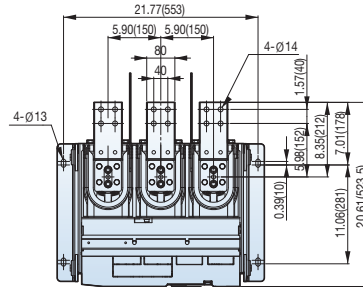

27kV, 25kA, 1200A

Type of circuit breaker

- UVL-27P25C12

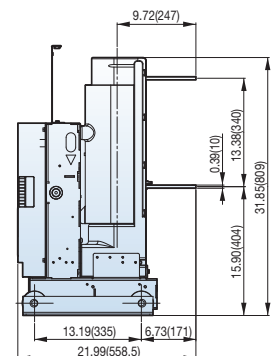
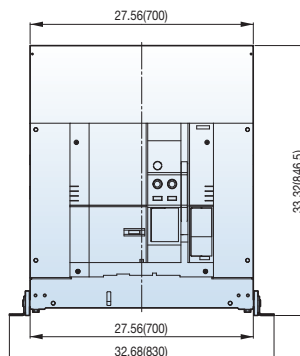
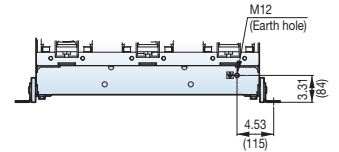
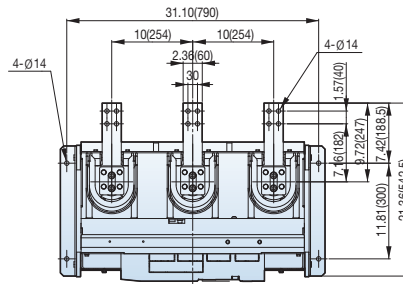

Memo

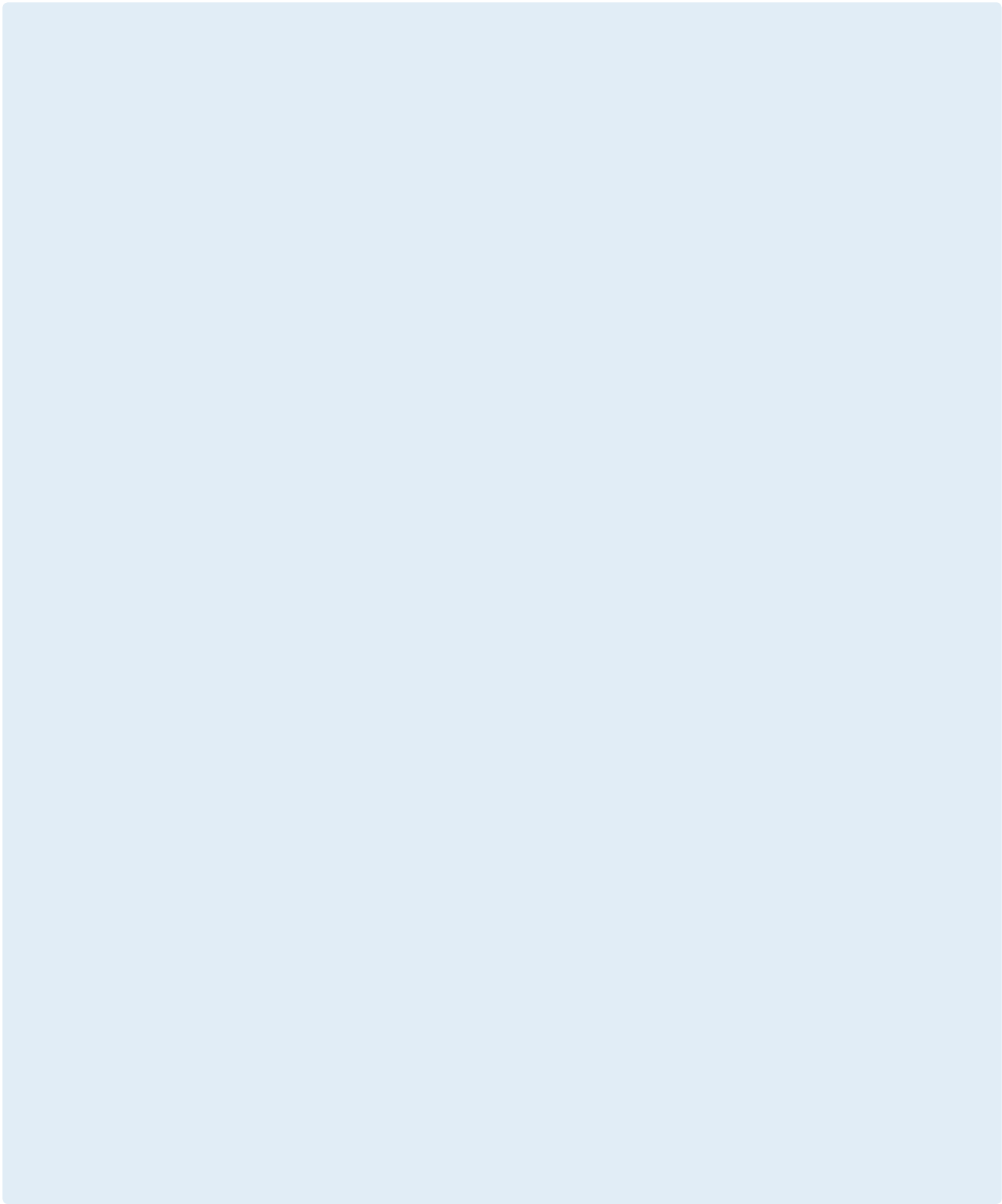

Susol UVM

Fixed type



Contents

▪ Ratings and description	20
▪ Selection guide of circuit breaker type	21
▪ Order form	22
▪ Dimensions	23

Ratings and description

UVM type, Fixed type

UVM-05P / UVM-15P  **US**

Circuit breaker type		UVM-05P				UVM-15P			
Rated voltage	Ur (kV)	4.76				15			
Rated withstand voltage	Power frequency (1min)	19				36			
	Lightening impulse (1.2×50µs)	60				95			
Rated short-circuit current	Isc (kA)	25	25	31.5	31.5	25	25	31.5	31.5
Rated normal current	Ir (A)	1200	2000	1200	2000	1200	2000	1200	2000
Rated frequency	fr (Hz)	60				60			
Rated short-circuit making current	Ip (kA) at 60 Hz	65	65	81.9	81.9	65	65	81.9	81.9
Rated short-time withstand current	Ik (kA)	25	25	31.5	31.5	25	25	31.5	31.5
	3sec	●	●	●	●	●	●	●	●
Operating sequence	O - 0.3s - CO - 15s - CO	●	●	●	●	●	●	●	●

Technical data

Opening time		Less than 0.04 sec
Rated breaking time		3 Cycle
No-load closing time		Less than 0.06 sec
Type test class	Mechanical endurance	M2 (10,000)
	Electrical endurance	Reference standard (page 201)
	Capacitance current switching	C2
Operate temperature	Low	-40 °C
	High	40 °C

Description for circuit breaker type

UVM type, Fixed type

UVM	15	P	32	A	12
Basic model name	Rated voltage (kV)	Version	Interrupting current (kA)	Phase distance/Compatibility	Rated current (A)
UVM Susol VCB	05 4.76 15 15	P Fixed	25 25 32 31.5	A 7"(178mm) C 10"(254mm)	12 1200A 20 2000A

Selection table of circuit breaker type

Ur [kV]	Isc [kA]	Ir [A]		Type of circuit breaker	Weight [kg]	Outline dimension H×W×D [mm]	Dimension page
		p = 178	p = 254				
4.76	25	1200	2000	UVM-05P25A12	85	670×589×509	23
				UVM-05P25A20	110	670×589×523.5	26
		1200	2000	UVM-05P25C12	100	670×819×509	24
	UVM-05P25C20			125	670×819×509	27	
	31.5	1200	2000	UVM-05P32A12	85	670×589×509	24
				UVM-05P32A20	110	670×589×523.5	26
1200		2000	UVM-05P32C12	100	670×819×509	25	
	UVM-05P32C20		125	670×819×509	27		
15	25	1200	2000	UVM-15P25A12	85	670×589×509	23
				UVM-15P25A20	110	670×589×523.5	26
		1200	2000	UVM-15P25C12	100	670×819×509	24
	UVM-15P25C20			125	670×819×509	27	
	31.5	1200	2000	UVM-15P32A12	85	670×589×509	25
				UVM-15P32A20	110	670×589×523.5	26
1200		2000	UVM-15P32C12	100	670×819×509	25	
	UVM-15P32C20		125	670×819×509	27		

Order form

Full description for circuit breaker

UVM type, Fixed type

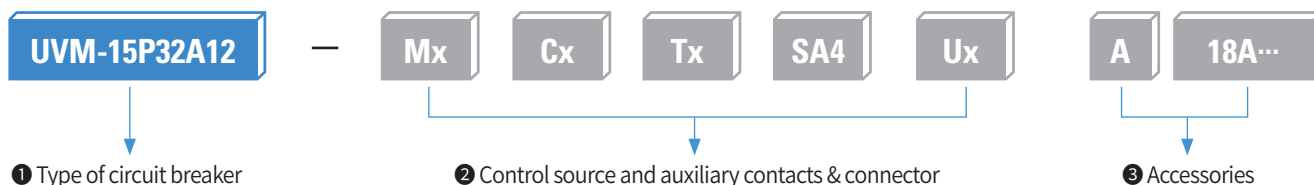

① Type of circuit breaker
(select from the previous page)

② Control source and auxiliary contacts & connector

③ Accessories

※ In case of selecting ③ Accessories, only type Symbol 'A' once. (ex. A18A)

Order form for circuit breaker

Please select only one of the items on the same horizontal line. (* Required selection)

UVM, VCB, Fixed type

(No extra charge extra charge)

① Type of VCB from selection table*		ea
② Control source		
Motor* (Mx)		page 154
<input type="radio"/> M0	<input type="radio"/> M1	<input type="radio"/> M2
<input type="radio"/> M3	<input type="radio"/> M4	<input type="radio"/> M5
<input type="radio"/> M6	<input type="radio"/> M7	<input type="radio"/> M8
Without motor	DC 110V	DC 200V ~ 250V
	DC 125V	DC 24V ~ 30V
	DC 48V ~ 60V	AC 48V
	AC 100V ~ 130V	AC 200V ~ 250V
Closing coil* (Cx)		page 155
<input type="radio"/> C0	<input type="radio"/> C1	<input type="radio"/> C2
<input type="radio"/> C3	<input type="radio"/> C4	<input type="radio"/> C5
<input type="radio"/> C6	<input type="radio"/> C7	<input type="radio"/> C8
Without CC	DC 110V	DC 200V ~ 250V
	DC 125V	DC 24V ~ 30V
	DC 48V ~ 60V	AC 48V
	AC 100V ~ 130V	AC 200V ~ 250V
Shunt trip coil* (Tx)		page 156
<input type="radio"/> T0	<input type="radio"/> T1	<input type="radio"/> T2
<input type="radio"/> T3	<input type="radio"/> T4	<input type="radio"/> T5
<input type="radio"/> T6	<input type="radio"/> T7	<input type="radio"/> T8
Without SHT	DC 110V	DC 200V ~ 250V
	DC 125V	DC 24V ~ 30V
	DC 48V ~ 60V	AC 48V
	AC 100V ~ 130V	AC 200V ~ 250V
Auxiliary contacts & Connector type*		page 159
<input type="checkbox"/> SA2 (4a4b Economic type, A-type)		<input type="checkbox"/> SQ2 (4a4b Standard, Q-type)
<input type="checkbox"/> SA4 (10a10b Economic type, A-type)		<input type="checkbox"/> SQ4 (10a10b Standard, Q-type)
Under voltage release (Ux)		page 160
<input type="radio"/> U0*	<input type="checkbox"/> U1	<input type="checkbox"/> U2
<input type="checkbox"/> U3	<input type="checkbox"/> U4	<input type="checkbox"/> U5
<input type="checkbox"/> U6	<input type="checkbox"/> U7	<input type="checkbox"/> U8
Without UVT	DC 110V	DC 200V ~ 250V
	DC 125V	DC 24V ~ 30V
	DC 48V ~ 60V	AC 48V
	AC 100V ~ 130V	AC 200V ~ 250V
※ Even without UVT, U0 must be selected to make VCB ordering code and description		
(Note) In case of DC24V control source(M4, C4, T4, U4), it is recommended to be used through Rated Control Voltage.		
③ Accessories		
Combination table		
U0	1	
U1~8		1
A1 & A2	1	
Available no. of Aux. contact		
Symbol	10a10b	
Standard	10 NO, 10 NC	
with A1	9 NO, 9 NC	
with A2	9 NO, 8 NC	
Secondary shunt trip coil		page 157
<input type="checkbox"/> A1 (Secondary shunt trip coil)		<input type="checkbox"/> A2 (Secondary shunt trip coil monitoring contact)
※ In case of selecting A1, maximum auxiliary contacts are 9a9b		※ In case of selecting A2, maximum auxiliary contacts are 9a8b
Keylock		page 162
<input type="checkbox"/> A7 (Keylock(Individual key))	<input type="checkbox"/> AG (Keylock(Same key))	
<input type="checkbox"/> AM (KirkKey, CAMLOCK type)	<input type="checkbox"/> AN (KirkKey, CN-22 type)	<input type="checkbox"/> AP (KirkKey, Double CAMLOCK type)
Button Padlock		page 163
<input type="radio"/> A8 (Button padlock)		<input type="radio"/> AX (Button padlock in open)
Lead wire*		page 164
<input type="radio"/> AA (Lead wire)		

Separately sold accessories

CTU (Coil test unit)	page 169
<input type="checkbox"/> 73873171221 CTU (Coil test unit)	
CTD (Condenser trip device)	page 170
<input type="checkbox"/> 76113143001 CTD (Condenser trip device) AC/DC 100V, 110V	
<input type="checkbox"/> 76113143002 CTD (Condenser trip device) AC/DC 200V, 220V	
UDC (UVT delay controller)	page 171
<input type="checkbox"/> 52773171282 UDC (UVT delay controller) AC/DC 100~130V	
<input type="checkbox"/> 52773171283 UDC (UVT delay controller) AC/DC 200~250V	
<input type="checkbox"/> 52773171281 UDC (UVT delay controller) DC 48~60V and AC 48V	

4.76kV, 25kA, 1200A

UVM type, Fixed type

Type of circuit breaker

UVM-05P25A12

[Unit: inch(mm)]

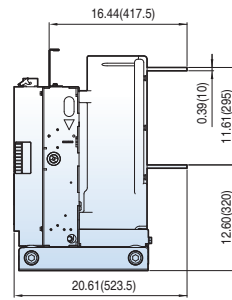
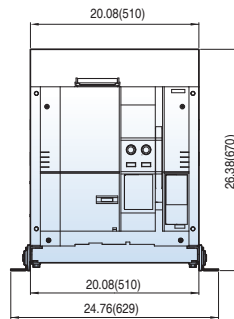
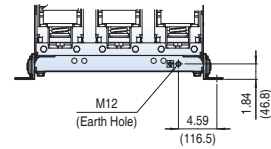
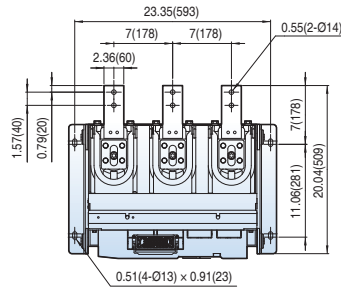

15kV, 25kA, 1200A

Type of circuit breaker

UVM-15P25A12

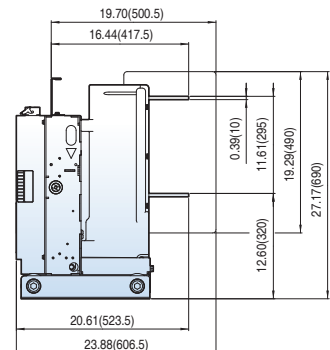
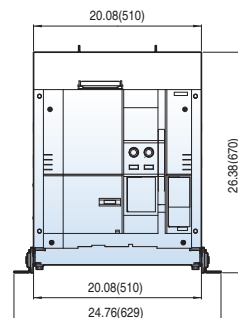
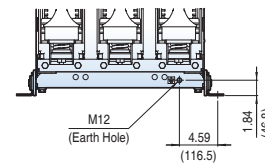
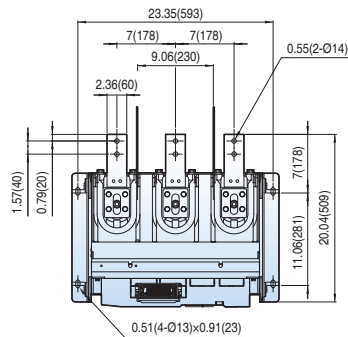

Dimensions

4.76/15kV, 25kA, 1200A

UVM type, Fixed type

Type of circuit breaker

UVM-05P25C12
UVM-15P25C12

[Unit: inch(mm)]

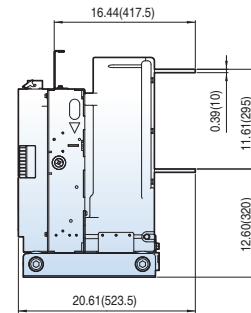
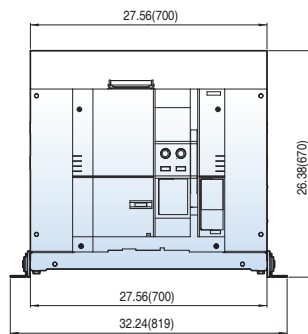
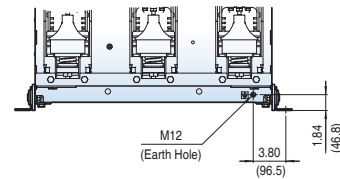
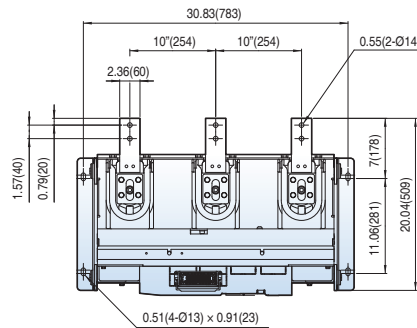

4.76, 31.5kA, 1200A

Type of circuit breaker

UVM-05P32A12

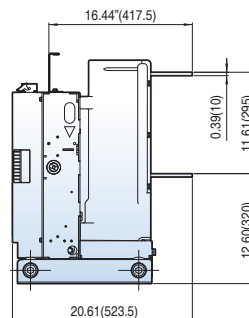
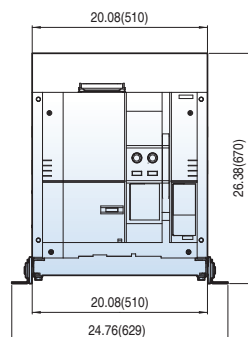
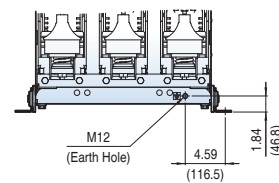
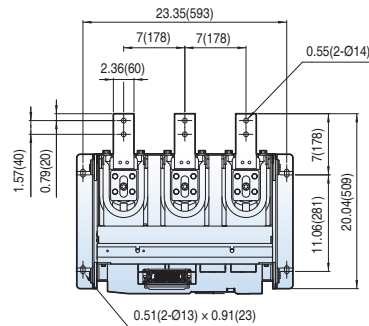

15kV, 31.5kA, 1200A

UVM type, Fixed type

Type of circuit breaker

UVM-15P32A12

[Unit: inch(mm)]

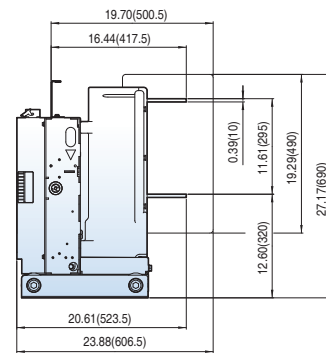
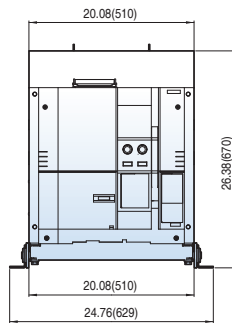
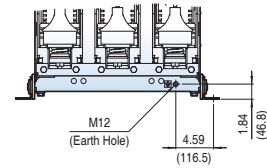
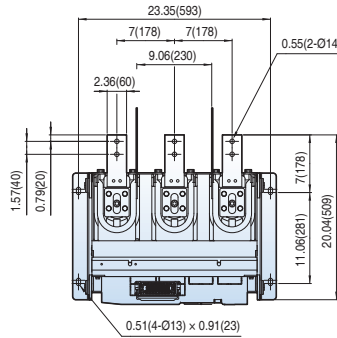

4.76/15kV, 31.5kA, 1200A

Type of circuit breaker

UVM-05P32C12
UVM-15P32C12

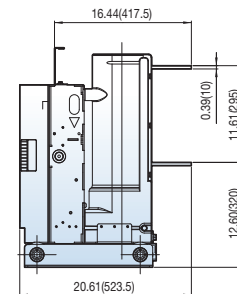
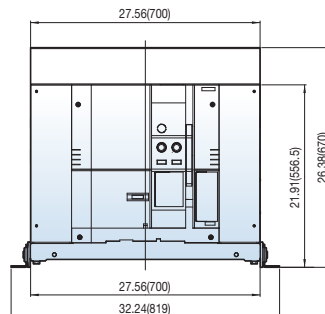
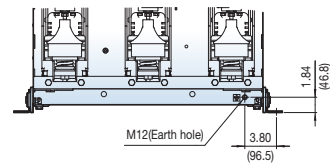
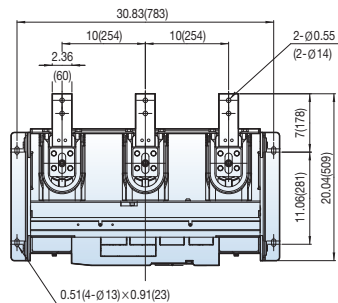

Dimensions

4.76kV, 25/31.5kA, 2000A

UVM type, Fixed type

Type of circuit breaker

- UVM-05P25A20
- UVM-05P32A20

[Unit: inch(mm)]

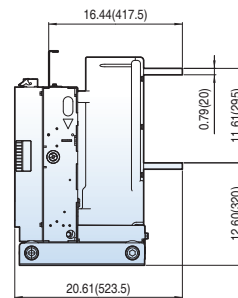
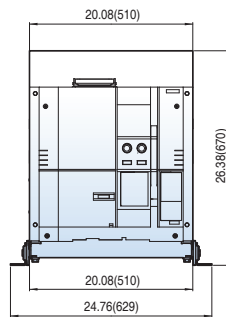
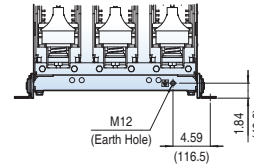
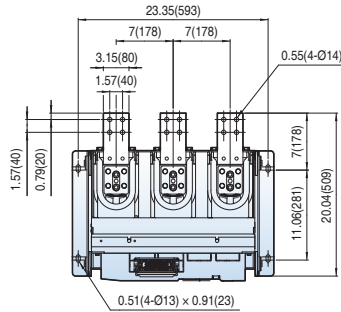

15kV, 25/31.5kA, 2000A

Type of circuit breaker

- UVM-15P25A20
- UVM-15P32A20

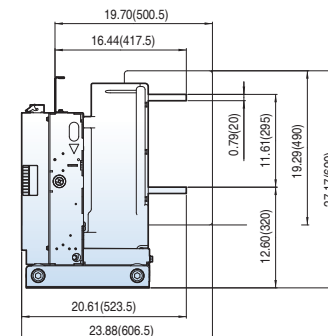
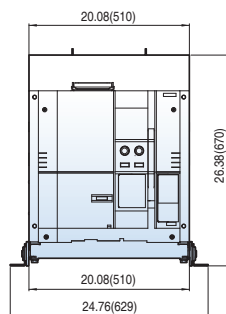
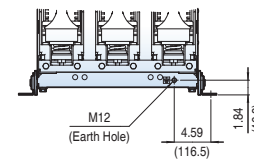
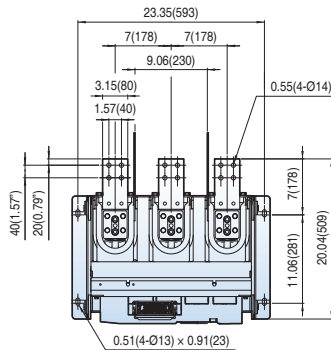

4.76/15kV, 25/31.5kA, 2000A

UVM type, Fixed type

Type of circuit breaker

- UVM-05P25C20
- UVM-05P32C20
- UVM-15P25C20
- UVM-15P32C20

[Unit: inch(mm)]

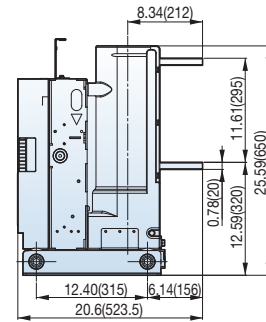
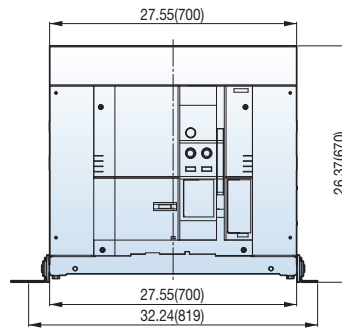
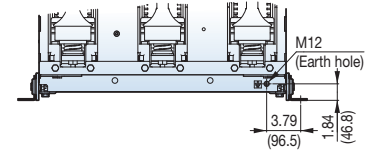
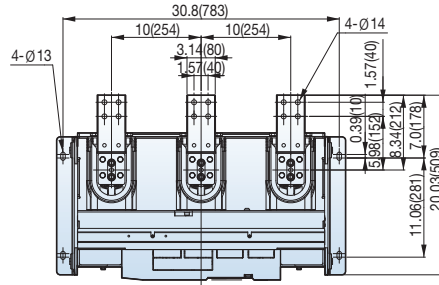

Memo

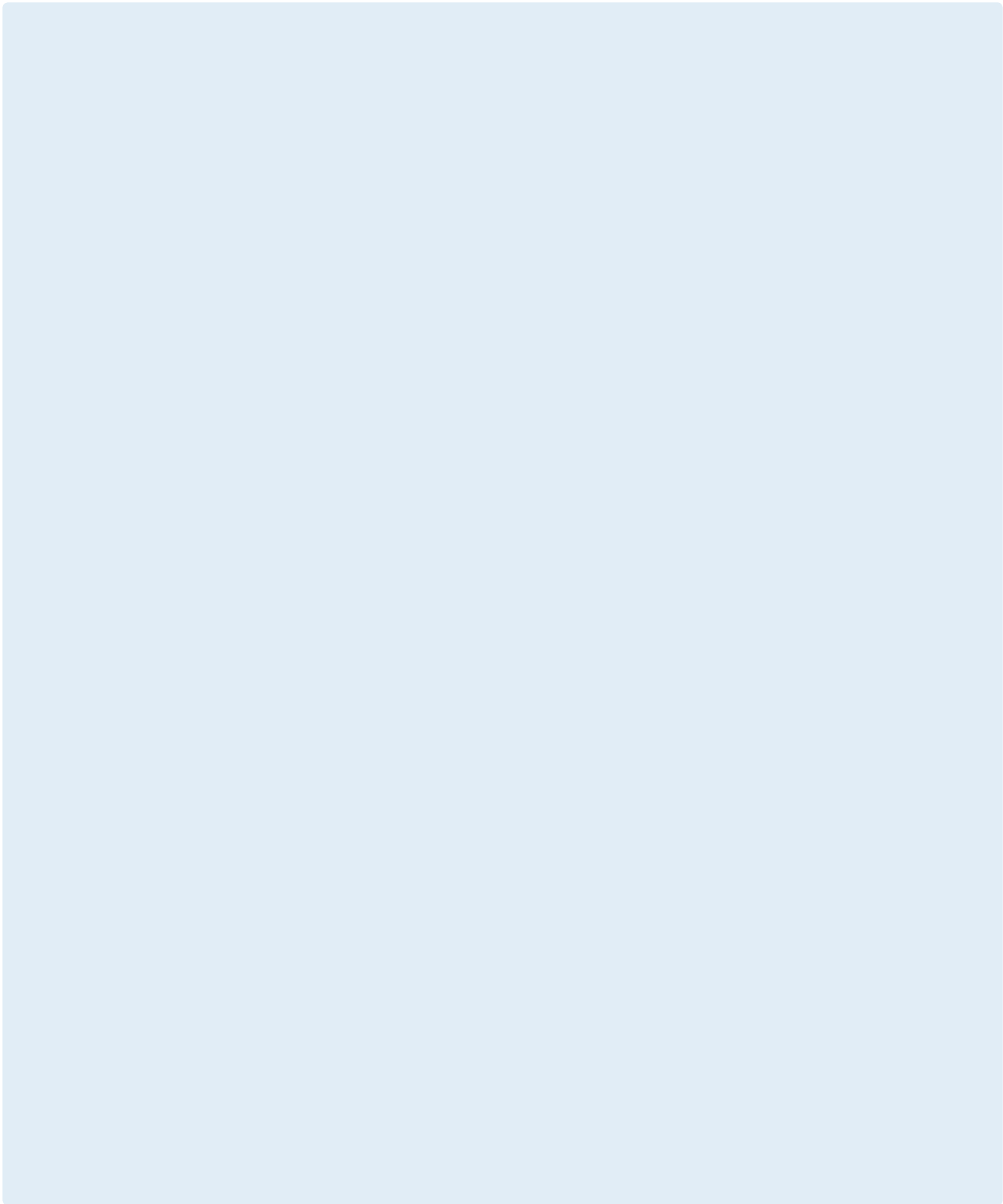

Susol UVH

Fixed type



Contents

▪ Ratings and description	30
▪ Selection guide of circuit breaker type	32
▪ Order form	34
▪ Dimensions	35

Ratings and description

UVH type, Fixed type

UVH-05P

Circuit breaker type			UVH-05P										
Rated voltage	Ur (kV)	4.76											
Rated withstand voltage	Power frequency (1min)	Ud (kV)	19										
	Lightening impulse (1.2×50μs)	Up (kV)	60										
Rated short-circuit current	Isc (kA)	25	25	31.5	31.5	40	40	40	40	50	50	50	50
Rated normal current	Ir (A)	3000	4000	3000	4000	1200	2000	3000	4000	1200	2000	3000	4000
Rated frequency	fr (Hz)	60	60	60	60	60	60	60	60	60	60	60	60
Rated short-circuit making current	Ip (kA) at 50 Hz	-	-	-	-	-	-	-	-	-	-	-	-
	Ip (kA) at 60 Hz	65	65	81.9	81.9	104	104	104	104	130	130	130	130
Rated short-time withstand current	Ik (kA)	25	25	31.5	31.5	40	40	40	40	50	50	50	50
	3sec	●	●	●	●	●	●	●	●	●	●	●	●
Operating sequence	O - 0.3s - CO - 15s - CO	●	●	●	●	●	●	●	●	●	●	●	●

UVH-15P

Circuit breaker type			UVH-15P										
Rated voltage	Ur (kV)	15											
Rated withstand voltage	Power frequency (1min)	Ud (kV)	36										
	Lightening impulse (1.2×50μs)	Up (kV)	95										
Rated short-circuit current	Isc (kA)	25	25	31.5	31.5	40	40	40	40	50	50	50	50
Rated normal current	Ir (A)	3000	4000	3000	4000	1200	2000	3000	4000	1200	2000	3000	4000
Rated frequency	fr (Hz)	60	60	60	60	60	60	60	60	60	60	60	60
Rated short-circuit making current	Ip (kA) at 50 Hz	-	-	-	-	-	-	-	-	-	-	-	-
	Ip (kA) at 60 Hz	65	65	81.9	81.9	104	104	104	104	130	130	130	130
Rated short-time withstand current	Ik (kA)	25	25	31.5	31.5	40	40	40	40	50	50	50	50
	3sec	●	●	●	●	●	●	●	●	●	●	●	●
Operating sequence	O - 0.3s - CO - 15s - CO	●	●	●	●	●	●	●	●	●	●	●	●

Technical data

Opening time		Less than 0.04 sec
Rated breaking time		3 Cycle
No-load closing time		Less than 0.06 sec
Type test class	Mechanical endurance	M2 (10,000)
	Electrical endurance	Reference standard (page 201)
	Apacitance current switching	C2
Operate temperature	Low	- 40 °C
	High	40 °C

UVH-27P  **US**

Circuit breaker type		UVH-27P									
Rated voltage	Ur (kV)	27									
Rated withstand voltage	Power frequency (1min)	Ud (kV)	60								
	Lightening impulse (1.2×50μs)	Up (kV)	125								
Rated short-circuit current	Isc (kA)	25	31.5				40				
Rated normal current	Ir (A)	2500	2750	1200	2000	2500	2750	1200	2000	2500	2750
Rated frequency	fr (Hz)	60	60	60	60	60	60	60	60	60	60
Rated short-circuit making current	I _p (kA) at 50 Hz	-	-	-	-	-	-	-	-	-	-
	I _p (kA) at 60 Hz	65	65	81.9	81.9	81.9	81.9	104	104	104	104
Rated short-time withstand current	I _k (kA)	25	25	31.5	31.5	31.5	31.5	40	40	40	40
	3sec	●	●	●	●	●	●	●	●	●	●
Operating sequence	O - 0.3s - CO - 15s - CO	●	●	●	●	●	●	●	●	●	●

UVH-38P (ANSI Type Test)

Circuit breaker type		UVH-38P			
Rated voltage	Ur (kV)	38			
Rated withstand voltage	Power frequency (1min)	Ud (kV)	80		
	Lightening impulse (1.2×50μs)	Up (kV)	170		
Rated short-circuit current	Isc (kA)	31.5	31.5	40	40
Rated normal current	Ir (A)	1200	2000	1200	2000
Rated frequency	fr (Hz)	60	60	60	60
Rated short-circuit making current	I _p (kA) at 60 Hz	81.9	81.9	104	104
Rated short-time withstand current	I _k (kA)	31.5	31.5	40	40
	3sec	●	●	●	●
Operating sequence	O - 0.3s - CO - 15s - CO	●	●	●	●

Technical data

Opening time		Less than 0.04 sec
Rated breaking time		3 Cycle
No-load closing time		Less than 0.06 sec
Type test class	Mechanical endurance	M2 (10,000)
	Electrical endurance	Reference standard (page 201)
	Apacitance current switching	C2
Operate temperature	Low	-40 °C
	High	40 °C

Selection guide of circuit breaker type

Description for circuit breaker type

UVH type, Fixed type

UVH	15	P	40	A	12
Basic model name	Rated voltage (kV)	Version	Interrupting current (kA)	Phase distance/Compatibility	Rated current (A)
UVH Susol VCB	05 4.76 15 15	P Fixed	25 25 32 31.5 40 40 50 50	A 7"(178mm) C 10"(254mm) L 12.59"(320mm)	12 1200A 20 2000A 30 3000A * 40 4000A *

* 3000/4000A have only 1 phase distance
3000A: 10"(254mm)
4000A: 12.59"(320mm)

Selection table of circuit breaker type

Ur [kV]	Isc [kA]	Ir [A]			Type of circuit breaker	Weight [kg]	Outline dimension H×W×D [mm]	Dimension page	
		p = 178	p = 254	p = 320					
4.76	25		3000	4000	UVH-05P25C30	245	753×878×630	36	
					UVH-05P25L40	385	949×1113×649.5	37	
	31.5		3000	4000	UVH-05P32C30	245	753×878×630	36	
					UVH-05P32L40	385	949×1113×649.5	37	
	40	1200 2000			UVH-05P40A12	170	753×624×619	35	
					UVH-05P40A20	185	753×624×619	35	
			1200 2000 3000		4000	UVH-05P40C12	185	753×878×619	36
						UVH-05P40C20	195	753×878×619	36
						UVH-05P40C30	245	753×878×630	36
						UVH-05P40L40	385	949×1113×649.5	37
	50	1200 2000			UVH-05P50A12	185	753×624×619	35	
					UVH-05P50A20	185	753×624×619	35	
		1200 2000 3000		4000	UVH-05P50C12	195	753×878×619	36	
					UVH-05P50C20	195	753×878×619	36	
					UVH-05P50C30	245	753×878×630	36	
					UVH-05P50L40	385	949×1113×649.5	37	
15	25		3000	4000	UVH-15P25C30	245	862.5×878×698.5	37	
					UVH-15P25L40	385	949×1113×649.5	37	
	31.5		3000	4000	UVH-15P32C30	245	862.5×878×698.5	37	
					UVH-15P32L40	385	949×1113×649.5	37	
	40	1200 2000			UVH-15P40A12	170	862.5×624×698.5	35	
					UVH-15P40A20	185	862.5×624×698.5	35	
			1200 2000 3000		4000	UVH-15P40C12	185	862.5×878×698.5	36
						UVH-15P40C20	195	862.5×878×698.5	36
						UVH-15P40C30	245	862.5×878×698.5	37
						UVH-15P40L40	385	949×1113×649.5	37
	50	1200 2000			UVH-15P50A12	185	862.5×624×698.5	35	
					UVH-15P50A20	185	862.5×624×698.5	35	
		1200 2000 3000		4000	UVH-15P50C12	195	862.5×878×698.5	36	
					UVH-15P50C20	195	862.5×878×698.5	36	
					UVH-15P50C30	245	862.5×878×698.5	37	
					UVH-15P50L40	385	949×1113×649.5	37	

Description for circuit breaker type

UVH type, Fixed type

UVH	38	P	32	E	12
Basic model name	Rated voltage (kV)	Version	Interrupting current (kA)	Phase distance/Compatibility	Rated current (A)
UVH SusoVCB	27 27 38 38	P Fixed	25 25 32 31.5 40 40	C 10"(254mm) E 11.8"(300mm)	12 1200A 20 2000A 25 2500A 28 2750A

Selection table of circuit breaker type

Ur [kV]	Isc [kA]	Ir [A]				Type of circuit breaker	Weight [kg]	Outline dimension H×W×D [mm]	Dimension page	
		p = 178	p = 254	p = 300	p = 320					
27	25		2500			UVH-27P25C25	300	932.5×878×795	39	
			2750			UVH-27P25C28	300	932.5×878×795	39	
	31.5			1200			UVH-27P32C12	260	932.5×878×795	38
				2000			UVH-27P32C20	260	932.5×878×795	38
				2500			UVH-27P32C25	300	932.5×878×795	39
				2750			UVH-27P32C28	300	932.5×878×795	39
	40			1200			UVH-27P40C12	260	932.5×878×795	38
				2000			UVH-27P40C20	260	932.5×878×795	38
			2500			UVH-27P40C25	300	932.5×878×795	39	
			2750			UVH-27P40C28	300	932.5×878×795	39	
38	31.5			1200		UVH-38H32E12	360	1100.5×963×1001.5	40	
				2000		UVH-38H32E20	360	1100.5×963×1001.5	40	
	40			1200		UVH-38H40E12	360	1100.5×963×1001.5	40	
				2000		UVH-38H40E20	360	1100.5×963×1001.5	40	

Order form

Full description for circuit breaker

UVH type, Fixed type

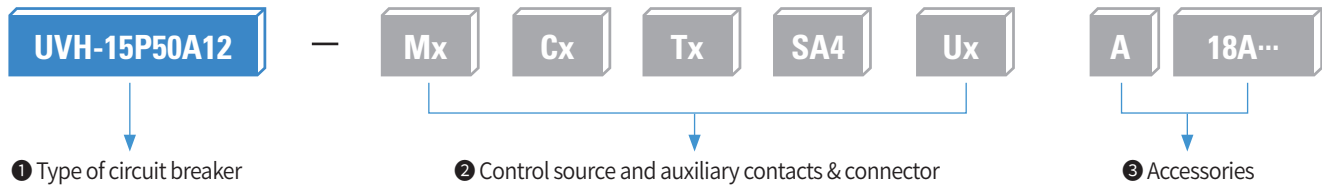

① Type of circuit breaker
(select from the previous page)

② Control source and auxiliary contacts & connector

③ Accessories

※ In case of selecting ③ Accessories, only type Symbol 'A' once. (ex. A18A)

Order form for circuit breaker

Please select only one of the items on the same horizontal line. (* Required selection)

UVH, VCB, Fixed type

(No extra charge extra charge)

① Type of VCB from selection table*		ea
② Control source		
Motor* (Mx)		page 154
<input type="radio"/> M0	<input type="radio"/> M1	<input type="radio"/> M2
Without motor	DC 110V	DC 200V ~ 250V
<input type="radio"/> M3	<input type="radio"/> M5	<input type="radio"/> M6
DC 125V	DC 48V ~ 60V	AC 48V
<input type="radio"/> M7	<input type="radio"/> M8	
AC 100V ~ 130V	AC 200V ~ 250V	
Closing coil* (Cx)		page 155
<input type="radio"/> C0	<input type="radio"/> C1	<input type="radio"/> C2
Without CC	DC 110V	DC 200V ~ 250V
<input type="radio"/> C3	<input type="radio"/> C5	<input type="radio"/> C6
DC 125V	DC 48V ~ 60V	AC 48V
<input type="radio"/> C7	<input type="radio"/> C8	
AC 100V ~ 130V	AC 200V ~ 250V	
Shunt trip coil* (Tx)		page 156
<input type="radio"/> T0	<input type="radio"/> T1	<input type="radio"/> T2
Without SHT	DC 110V	DC 200V ~ 250V
<input type="radio"/> T3	<input type="radio"/> T5	<input type="radio"/> T6
DC 125V	DC 48V ~ 60V	AC 48V
<input type="radio"/> T7	<input type="radio"/> T8	
AC 100V ~ 130V	AC 200V ~ 250V	
Auxiliary contacts & Connector type*		page 159
<input type="radio"/> SA2(4a4b Economic type, A-type)	<input type="checkbox"/> SQ2(4a4b Standard, Q-type)	
<input type="checkbox"/> SA4(10a10b Economic type, A-type)	<input type="checkbox"/> SQ4(10a10b Standard, Q-type)	
Under voltage release (Ux)		page 160
<input type="radio"/> U0	<input type="checkbox"/> U1	<input type="checkbox"/> U2
Without UVT	DC 110V	DC 200V ~ 250V
<input type="checkbox"/> U3	<input type="checkbox"/> U5	<input type="checkbox"/> U6
DC 125V	DC 48V ~ 60V	AC 48V
<input type="checkbox"/> U7	<input type="checkbox"/> U8	
AC 100V ~ 130V	AC 200V ~ 250V	
※ Even without UVT, U0 must be selected to make VCB ordering code and description		
Note) In case of DC24V control source(M4, C4, T4, U4), it is recommended to be used through Rated Control Voltage.		
③ Accessories		
Combination table	Secondary shunt trip coil	page 157
U0 1	<input type="checkbox"/> A1 (Secondary shunt trip coil)	<input type="checkbox"/> A2 (Secondary shunt trip coil monitoring contact)
U1-8 1	※ In case of selecting A2, maximum auxiliary contacts are 10a9b	
A1 & A2 1	Latch checking s/w	page 161
	<input type="checkbox"/> A6	
	※ In case of selecting UVT(U1~U8), Latch checking s/w should be selected.	
Available no. of Aux. contact	Keylock	page 162
Symbol 10a10b	<input type="checkbox"/> A7 (Keylock(Individual key))	<input type="checkbox"/> AG (Keylock(Same key))
Standard 10 NO, 10 NC	<input type="checkbox"/> AM (Kirk key, CAMLOCK type)	
with A1 10 NO, 10 NC	Button padlock	page 163
with A2 10 NO, 9 NC	<input type="radio"/> A8 (Button padlock)	<input type="radio"/> AX (Button padlock in option)
	Lead wire*	page 164
	<input type="radio"/> AA (Lead wire)	

Separately sold accessories

Charge handle	<input type="checkbox"/> 55213143046	page 178
CTU (Coil test unit)		page 169
	<input type="checkbox"/> 73873171221 CTU (Coil test unit)	
CTD (Condenser trip device)		page 170
	<input type="checkbox"/> 76113143001 CTD (Condenser trip device) AC/DC 100V, 110V	
	<input type="checkbox"/> 76113143002 CTD (Condenser trip device) AC/DC 200V, 220V	
UDC (UVT delay controller)		page 171
	<input type="checkbox"/> 52773171282 UDC (UVT delay controller) AC/DC 100~130V	
	<input type="checkbox"/> 52773171283 UDC (UVT delay controller) AC/DC 200~250V	
	<input type="checkbox"/> 52773171281 UDC (UVT delay controller) DC 48~60V and AC 48V	

4.76kV, 40/50kA, 1200/2000A

UVH type, Fixed type

Type of circuit breaker

- UVH-05P40A12
- UVH-05P40A20
- UVH-05P50A12
- UVH-05P50A20

[Unit: inch(mm)]

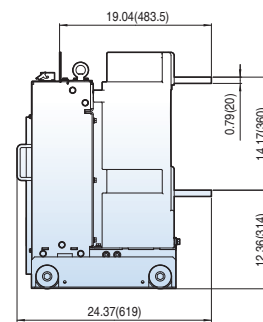
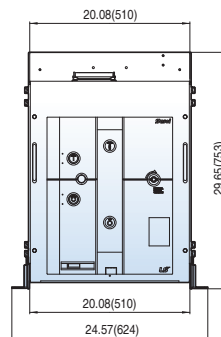
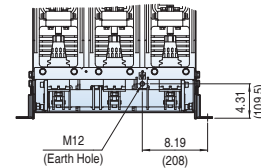
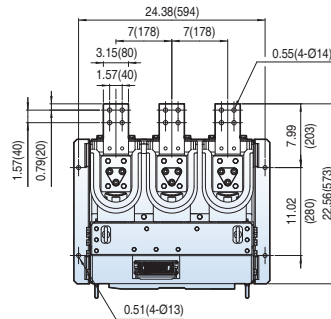

15kV, 40/50kA, 1200/2000A

Type of circuit breaker

- UVH-15P40A12
- UVH-15P40A20
- UVH-15P50A12
- UVH-15P50A20

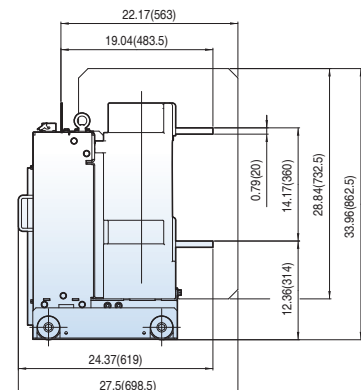
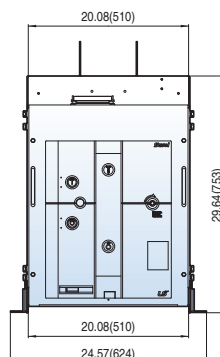
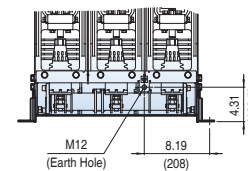
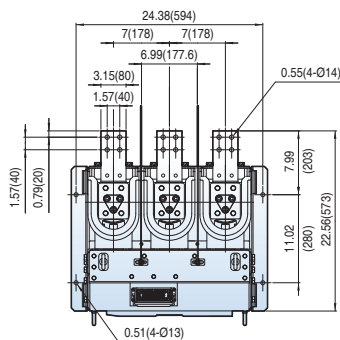

Dimensions

4.76/15kV, 40/50kA, 1200/2000A

UVH type, Fixed type

Type of circuit breaker

- UVH-05P40C12
- UVH-05P40C20
- UVH-05P50C12
- UVH-05P50C20
- UVH-15P40C12
- UVH-15P40C20
- UVH-15P50C12
- UVH-15P50C20

[Unit: inch(mm)]

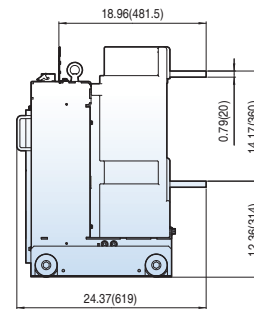
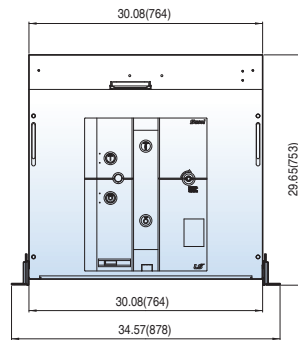
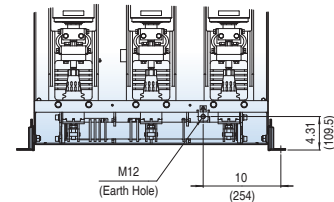
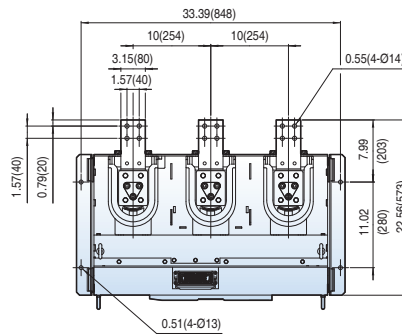

4.76kV, 25/31.5/40/50kA, 3000A

Type of circuit breaker

- UVH-05P25C30
- UVH-05P32C30
- UVH-05P40C30
- UVH-05P50C30

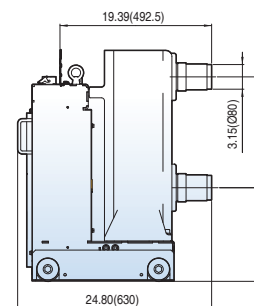
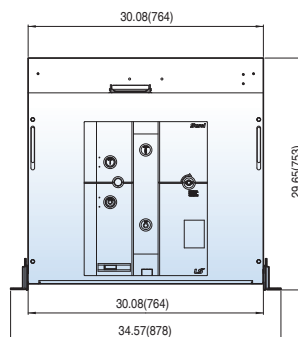
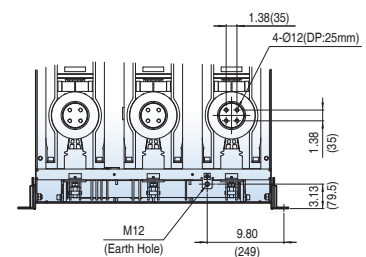
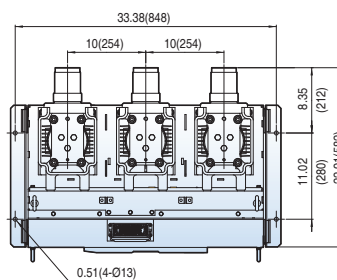

15kV, 25/31.5/40/50kA, 3000A

UVH type, Fixed type

Type of circuit breaker

- UVH-15P25C30
- UVH-15P32C30
- UVH-15P40C30
- UVH-15P50C30

[Unit: inch(mm)]

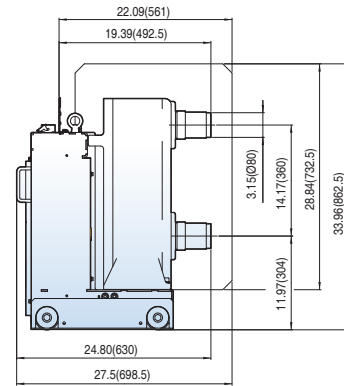
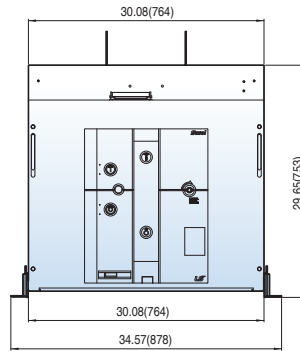
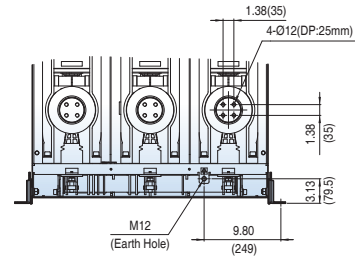
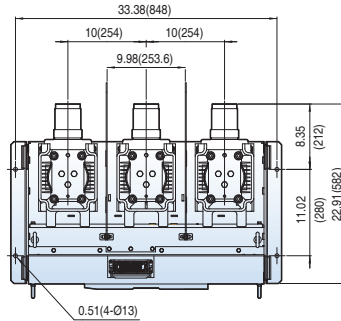

4.76/15kV, 25/31.5/40/50kA, 4000A

Type of circuit breaker

- UVH-05P25L40
- UVH-05P32L40
- UVH-05P40L40
- UVH-05P50L40
- UVH-15P25L40
- UVH-15P32L40
- UVH-15P40L40
- UVH-15P50L40

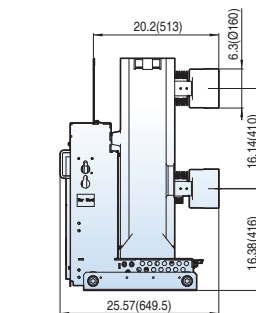
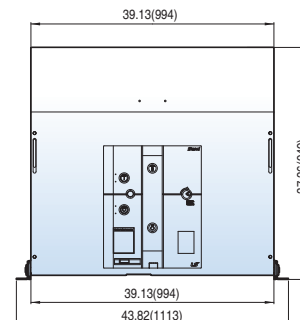
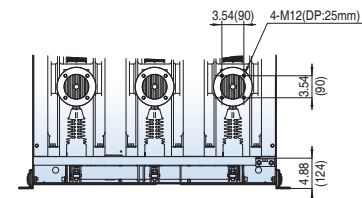
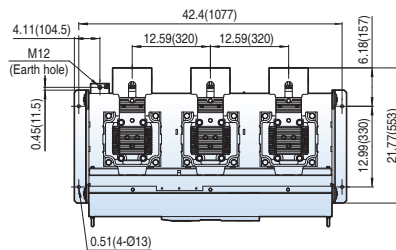

Dimensions

27kV, 31.5/40kA, 1200/2000A

UVH type, Fixed type

Type of circuit breaker

- UVH-27P32C12
- UVH-27P32C20
- UVH-27P40C12
- UVH-27P40C20

[Unit: inch(mm)]

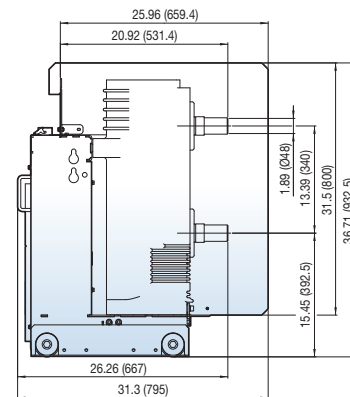
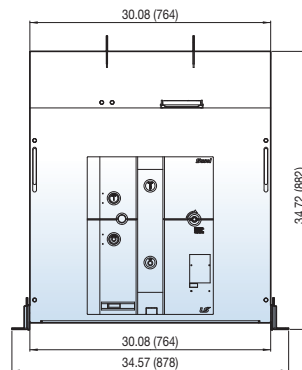
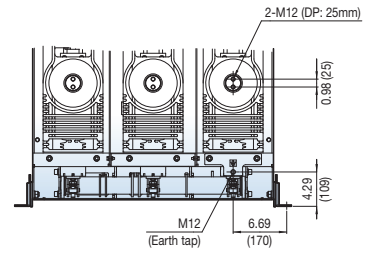
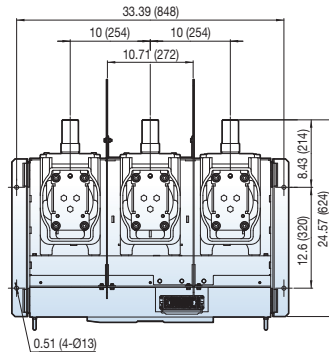

27kV, 25/31.5/40kA, 2500A

UVH type, Fixed type

Type of circuit breaker

- UVH-27P25C25
- UVH-27P32C25
- UVH-27P40C25

[Unit: inch(mm)]

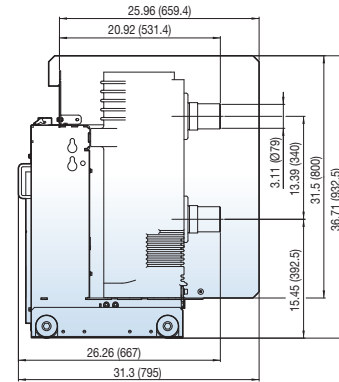
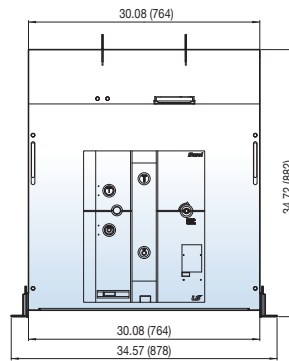
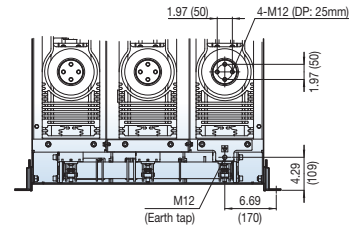
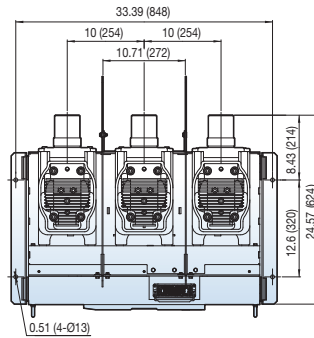

27kV, 25/31.5/40kA, 2750A

Type of circuit breaker

- UVH-27P25C28
- UVH-27P32C28
- UVH-27P40C28

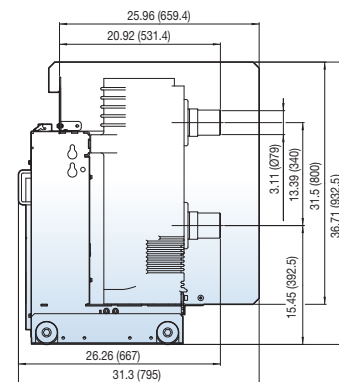
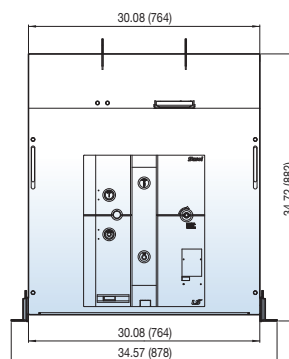
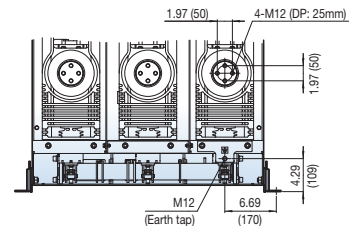
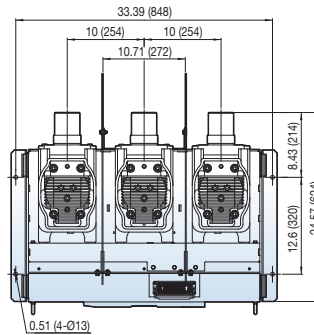

Dimensions

38kV, 31.5/40kA, 1200/2000A

UVH type, Fixed type

[Unit: inch(mm)]

Type of circuit breaker

- UVH-38P32E12
- UVH-38P32E20
- UVH-38P40E12
- UVH-38P40E20

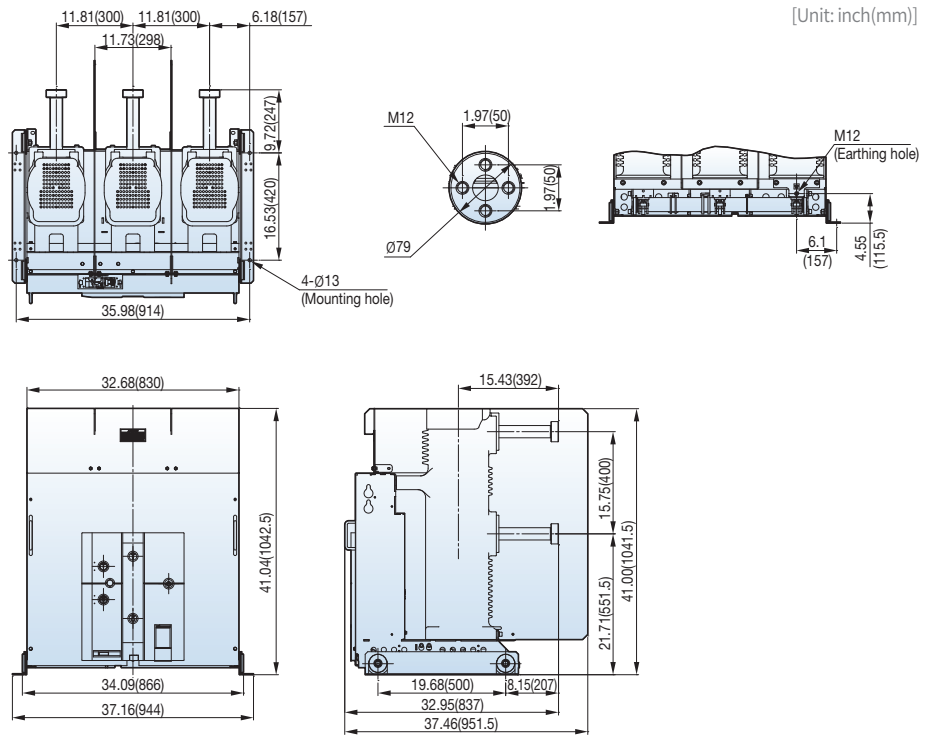

Susol UVL

Drawout type
(Draw in/out by using screw)



Contents

▪ Ratings and description	42
▪ Selection guide of circuit breaker type	43
▪ Order form	45
▪ Dimensions	47

Ratings and description

UVL type, Drawout type



Circuit breaker type		UVL-05H				UVL-15H			
Rated voltage	Ur (kV)	4.76				15			
Rated withstand voltage	Power frequency (1min)	19				36			
	Lightening impulse (1.2×50µs)	60				95			
Rated short-circuit current	Isc (kA)	25	25	31.5	31.5	25	25	31.5	31.5
Rated normal current	Ir (A)	1200	2000	1200	2000	1200	2000	1200	2000
Rated frequency	fr (Hz)	50/60	50/60	50/60	50/60	50/60	50/60	50/60	50/60
Rated short-circuit making current	Ip (kA) at 60 Hz	65	65	81.9	81.9	65	65	81.9	81.9
Rated short-time withstand current	Ik (kA)	25	25	31.5	31.5	25	25	31.5	31.5
	3sec	●	●	●	●	●	●	●	●
Operating sequence	O - 0.3s - CO - 15s - CO	●	●	●	●	●	●	●	●

Technical data

Opening time		Less than 0.04 sec
Rated breaking time		3 Cycle
No-load closing time		Less than 0.06 sec
Type test class	Mechanical endurance	M2 (10,000)
	Electrical endurance	Reference standard (page 201)
	Apacitance current switching	C2
Operate temperature	Low	-40 °C
	High	40 °C

Description for circuit breaker type

UVL type, Drawout type

Withdrawal VCB, Cradle for MCSG

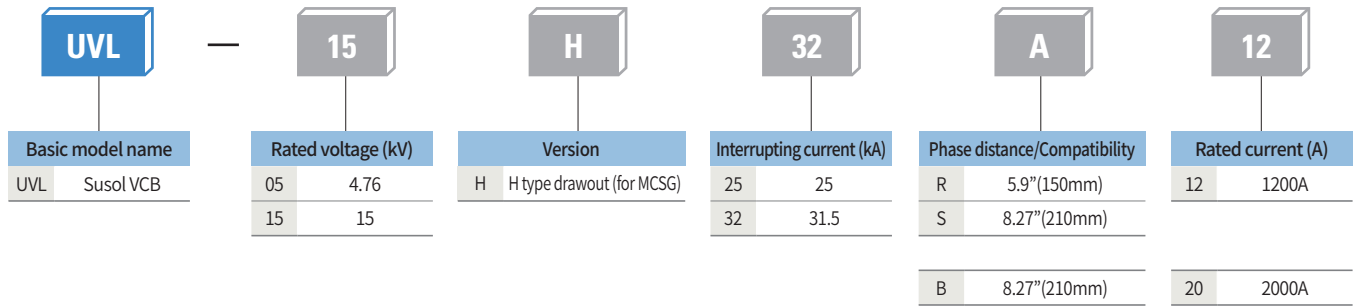

Selection table of circuit breaker type

Select withdrawal VCB/Cradle with same horizontal line.

Ur [kV]	Isc [kA]	Ir [A]		Type of circuit breaker	Weight [kg]	Outline dimension H×W×D [mm]	Dimension page
		p = 150	p = 210				
4.76	25	1200		UVL-05H25R12	130	691×503×642	47
			1200	UVL-05H25S12	140	691×653×642	47
			2000	UVL-05H25B20	160	691×653×642	48
	31.5	1200		UVL-05H32R12	130	691×503×642	47
			1200	UVL-05H32S12	140	691×653×642	47
			2000	UVL-05H32B20	160	691×653×642	48
15	25	1200		UVL-15H25R12	130	691×503×642	47
			1200	UVL-15H25S12	140	691×653×642	47
			2000	UVL-15H25B20	160	691×653×642	48
	31.5	1200		UVL-15H32R12	130	691×503×642	47
			1200	UVL-15H32S12	140	691×653×642	47
			2000	UVL-15H32B20	160	691×653×642	48

Selection guide of circuit breaker type

Description for Cradle

UVL type, Drawout type

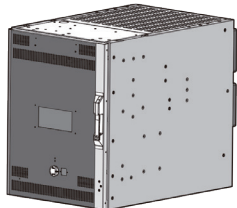

He type

UVCL		15		H		32		P		12	
Basic model name		Rated voltage (kV)		Version		Interrupting current (kA)		Phase distance/Compatibility		Rated current (A)	
UVCL	Susol VCB Cradle	05	4.76	He	Compact MCSG (ARC)	25	25	A	5.9"(150mm)	12	1200A
		15	15			32	31.5	B	8.27"(210mm)	20	2000A

Selection table of cradle

Arc resistance	Type of cradle	Outline dimension H×W×D [mm]	Dimension page
●	UVCL-05He25A12	950×600×1467	49
●	UVCL-05He25B12	950×750×1467	50
●	UVCL-05He25B20	950×750×1464.2	51
●	UVCL-05He32A12	950×600×1467	49
●	UVCL-05He32B12	950×750×1467	50
●	UVCL-05He32B20	950×750×1464.2	51
●	UVCL-15He25A12	950×600×1467	49
●	UVCL-15He25B12	950×750×1467	50
●	UVCL-15He25B20	950×750×1464.2	51
●	UVCL-15He32A12	950×600×1467	49
●	UVCL-15He32B12	950×750×1467	50
●	UVCL-15He32B20	950×750×1464.2	51

Full description for circuit breaker

UVL type, Drawout type

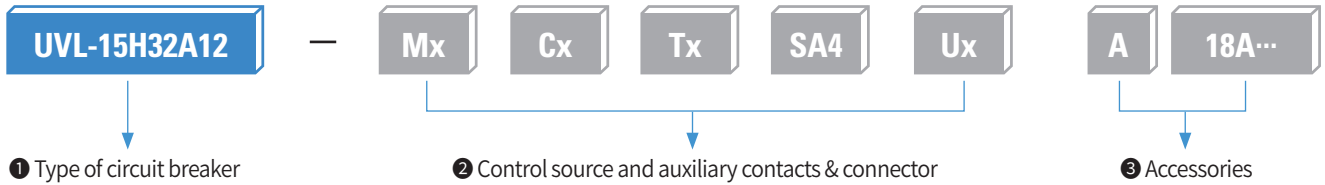

1 Type of circuit breaker
(select from the previous page)

2 Control source and auxiliary contacts & connector

3 Accessories

※ In case of selecting 3 Accessories, only type Symbol 'A' once. (ex. A18A)

Order form for circuit breaker

Please select only one of the items on the same horizontal line. (* Required selection)

ULV, VCB, Drawout type

(○ no extra charge □ extra charge)

1 Type of VCB from selection table*		ea
2 Control source		
Motor* (Mx)		page 154
<input type="radio"/> M0 Without motor	<input type="radio"/> M1 DC 110V	<input type="radio"/> M2 DC 200V ~ 250V
<input type="radio"/> M3 DC 125V	<input type="radio"/> M4 DC 24V ~ 30V	<input type="radio"/> M5 DC 48V ~ 60V
<input type="radio"/> M6 AC 48V	<input type="radio"/> M7 AC 100V ~ 130V	<input type="radio"/> M8 AC 200V ~ 250V
Closing coil* (Cx)		page 155
<input type="radio"/> C0 Without CC	<input type="radio"/> C1 DC 110V	<input type="radio"/> C2 DC 200V ~ 250V
<input type="radio"/> C3 DC 125V	<input type="radio"/> C4 DC 24V ~ 30V	<input type="radio"/> C5 DC 48V ~ 60V
<input type="radio"/> C6 AC 48V	<input type="radio"/> C7 AC 100V ~ 130V	<input type="radio"/> C8 AC 200V ~ 250V
Shunt trip coil* (Tx)		page 156
<input type="radio"/> T0 Without SHT	<input type="radio"/> T1 DC 110V	<input type="radio"/> T2 DC 200V ~ 250V
<input type="radio"/> T3 DC 125V	<input type="radio"/> T4 DC 24V ~ 30V	<input type="radio"/> T5 DC 48V ~ 60V
<input type="radio"/> T6 AC 48V	<input type="radio"/> T7 AC 100V ~ 130V	<input type="radio"/> T8 AC 200V ~ 250V
Auxiliary contacts & Connector type*		page 159
<input type="radio"/> SQ4 (10a10b Standard type, Q-type)		
Under voltage release (Ux)		page 160
<input type="radio"/> U0 Without UVT	<input type="checkbox"/> U1 DC 110V	<input type="checkbox"/> U2 DC 200V ~ 250V
<input type="checkbox"/> U3 DC 125V	<input type="checkbox"/> U4 DC 24V ~ 30V	<input type="checkbox"/> U5 DC 48V ~ 60V
<input type="checkbox"/> U6 AC 48V	<input type="checkbox"/> U7 AC 100V ~ 130V	<input type="checkbox"/> U8 AC 200V ~ 250V
※ Even without UVT, U0 must be selected to make VCB ordering code and description		
Note) In case of DC24V control source(M4, C4, T4, U4), it is recommended to be used through Rated Control Voltage.		
3 Accessories		
Combination table		
U0	1	
U1-8		1
A1 & A2	1	
Available no. of Aux. contact		
Symbol	10a10b	
Standard	10 NO, 10 NC	
with A1	9 NO, 9 NC	
with A2	9 NO, 8 NC	
Secondary shunt trip coil		page 157
<input type="checkbox"/> A1 (Secondary shunt trip coil)		<input type="checkbox"/> A2 (Secondary shunt trip coil monitoring contact)
※ In case of selecting A1, maximum auxiliary contacts are 9a9b		※ In case of selecting A2, maximum auxiliary contacts are 9a8b
Position switch		page 161
<input type="checkbox"/> A3 (Test:1a1s, Service: 2s)		<input type="checkbox"/> A4 (Test:2a, Service: 2a)
※ In case of selecting UVT(U1~U8), Latch checking s/w should be selected.		<input type="checkbox"/> A5 (Test:1a1s, Service: 1a1s)
Keylock		page 162
<input type="checkbox"/> A7 (Keylock(Individual key))		<input type="checkbox"/> AG (Keylock(Same key))
<input type="checkbox"/> AM (Kirk key, CAMLOCK type)		<input type="checkbox"/> AN (Kirk key, CN-22 type)
<input type="checkbox"/> AP (Kirk key, Double CAMLOCK type)		
Button padlock*		page 163
<input type="radio"/> A8 (Button padlock)		<input type="radio"/> AX (Button padlock in open)
Lead wire*		page 164
<input type="radio"/> AA (Lead wire)		
※ In case of selecting Lead Wire as a cradle option, no need to select it with the breaker.		
Plug Interlock*		page 165
<input type="radio"/> AC		
Padlock*		page 165
<input type="radio"/> AD		
MOC operator*		page 166
<input type="radio"/> AE		

Separately sold accessories

CTU (Coil test unit)	<input type="checkbox"/> 73873171221 CTU (Coil test unit)	page 169
CTD (Condenser trip device)	<input type="checkbox"/> 76113143001 CTD (Condenser trip device) AC/DC 100V, 110V	page 170
	<input type="checkbox"/> 76113143002 CTD (Condenser trip device) AC/DC 200V, 220V	
UDC (UVT delay controller)	<input type="checkbox"/> 52773171282 UDC (UVT delay controller) AC/DC 100~130V	page 171
	<input type="checkbox"/> 52773171283 UDC (UVT delay controller) AC/DC 200~250V	
	<input type="checkbox"/> 52773171281 UDC (UVT delay controller) DC 48-60V and AC 48V	

Order form

Full description for cradle

UVL type, Drawout type

UVCL-05He25A12

① Type of cradle
(select from the previous page)

A **236**

③ Accessories

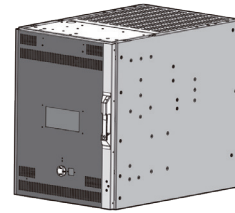

He type

Order form for cradle

Please select only one of the items on the same horizontal line. (* Required selection)

UVL, VCB, Drawout type

(○ no extra charge □ extra charge)

① Type of VCB from selection table*	Quantity	ea
② Control source		
Lead wire*		page 164
<input type="checkbox"/> A1 (4a4b) <input type="checkbox"/> A2 (10a10b)		
※ A1, A2 options are the same as the AA option that can be selected with the breaker. And when it is selected as a cradle option, it will be attached to the cradle and shipped.		
Standard set (Shutter padlock, TOC, MOC)*		page 172
<input type="checkbox"/> A3 (4a4b(MOC,TOC))		
Door		page 174
<input type="checkbox"/> A6		
Door interlock		page 175
<input type="checkbox"/> A7		
Door emergency push button		page 175
<input type="checkbox"/> A8		

Separately sold accessories

Racking In/Out handle		page 179
<input type="checkbox"/> 55223172407 (Normal type) <input type="checkbox"/> 55223172403 (Normal type (Extension)) <input type="checkbox"/> 55223172405 (Universal type) <input type="checkbox"/> 55223172406 (Universal type(Extension))		

4.76/15kV, 25/31.5kA, 1200A

UVL type, Drawout type

Type of circuit breaker

- UVL-05H25R12
- UVL-05H32R12
- UVL-15H25R12
- UVL-15H32R12

[Unit: inch(mm)]

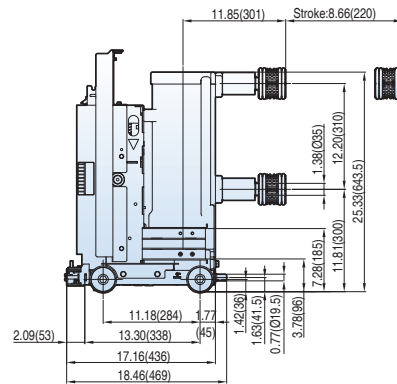
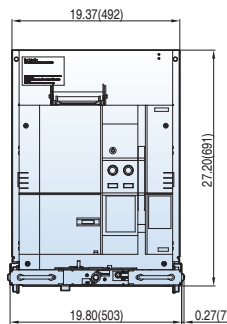
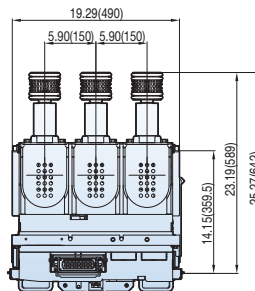

4.76/15kV, 25/31.5kA, 1200A

Type of circuit breaker

- UVL-05H25S12
- UVL-05H32S12
- UVL-15H25S12
- UVL-15H32S12

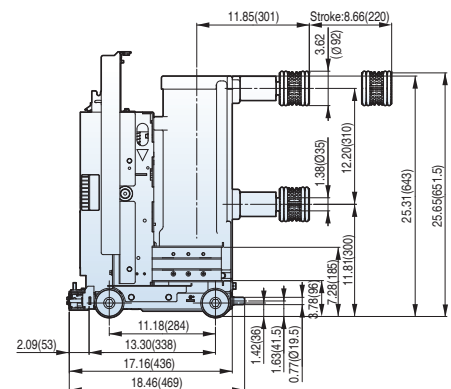
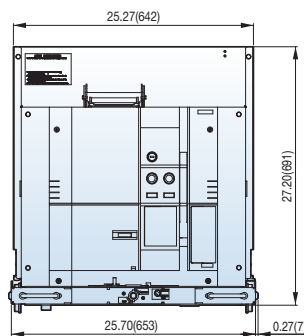
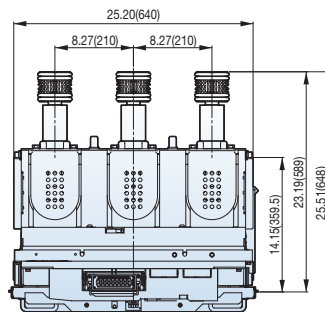

Dimensions

4.76/15kV, 25/31.5kA, 2000A

UVL type, Drawout type

Type of circuit breaker

- UVL-05H25B20
- UVL-05H32B20
- UVL-15H25B20
- UVL-15H32B20

[Unit: inch(mm)]

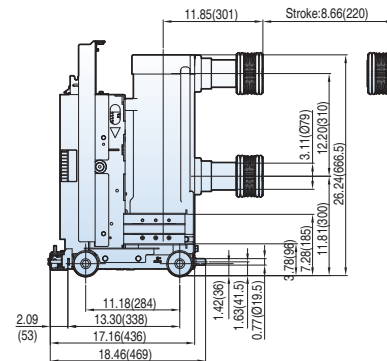
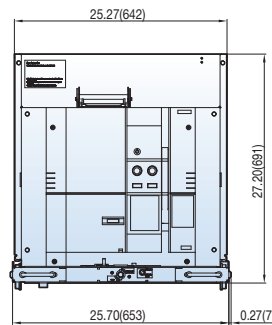
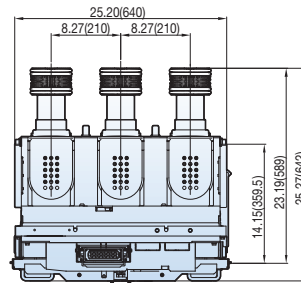

4.76/15kV, 25/31.5kA, 1200A

UVL type, Drawout type

Type of cradle

- UVCL-05He25A12
- UVCL-05He32A12
- UVCL-15He25A12
- UVCL-15He32A12

[Unit: inch(mm)]

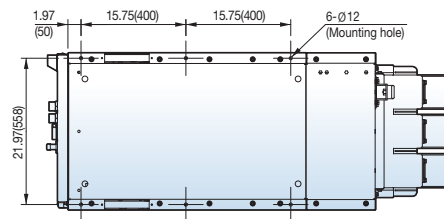
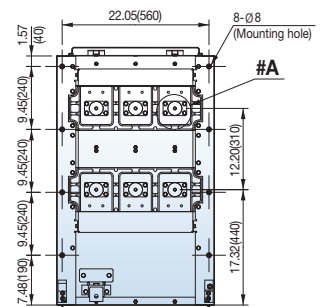
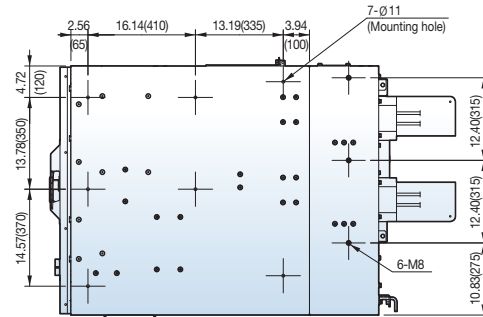
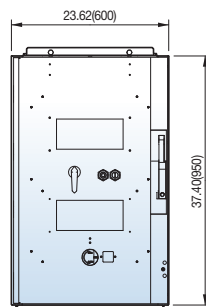
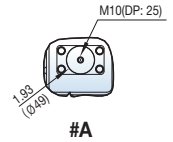
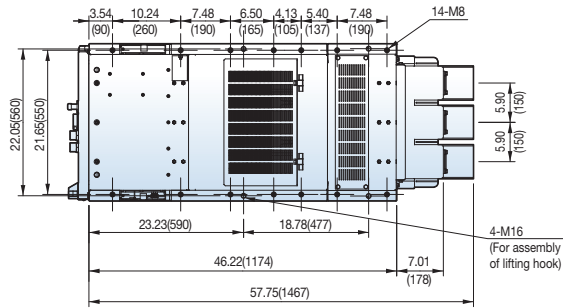

Dimensions

4.76/15kV, 25/31.5kA, 1200A

UVL type, Drawout type

Type of cradle

- UVCL-05He25B12
- UVCL-05He32B12
- UVCL-15He25B12
- UVCL-15He32B12

[Unit: inch(mm)]

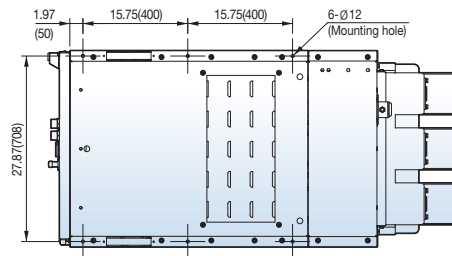
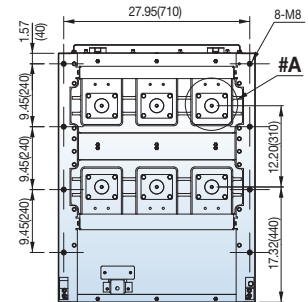
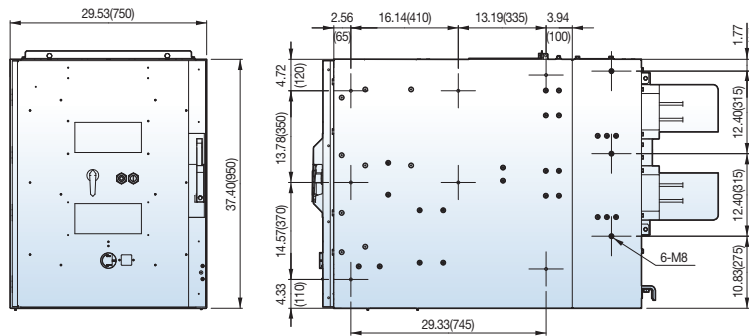
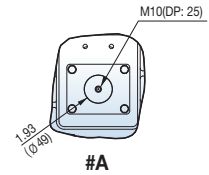
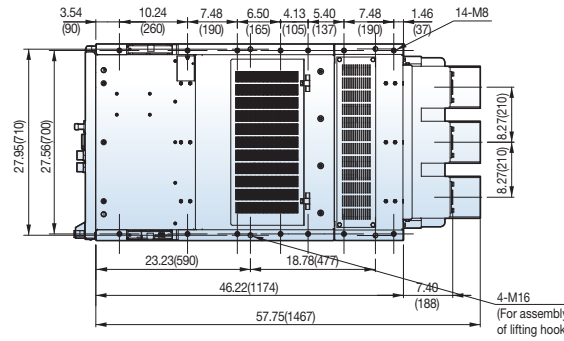

4.76/15kV, 25/31.5kA, 2000A

UVL type, Drawout type

Type of cradle

- UVCL-05He25B20
- UVCL-05He32B20
- UVCL-15He25B20
- UVCL-15He32B20

[Unit: inch(mm)]

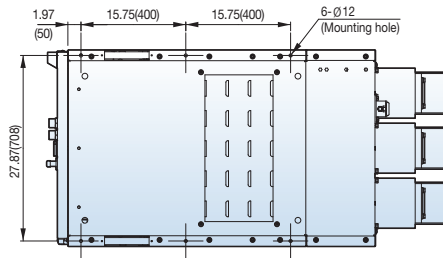
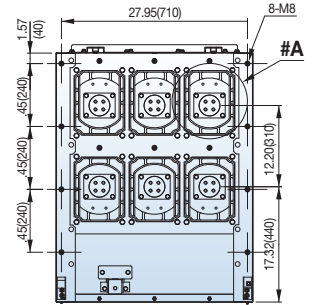
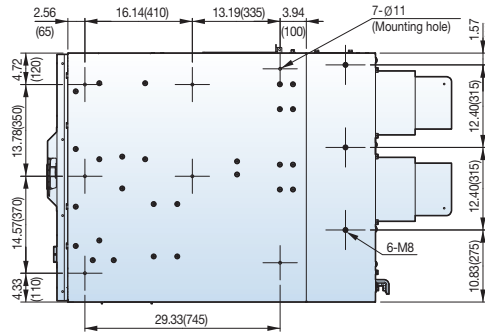
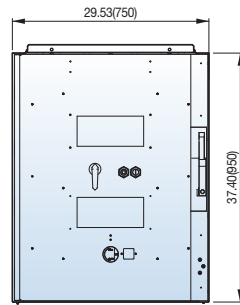
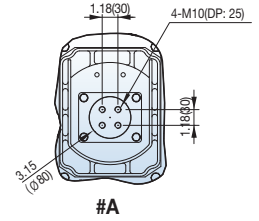
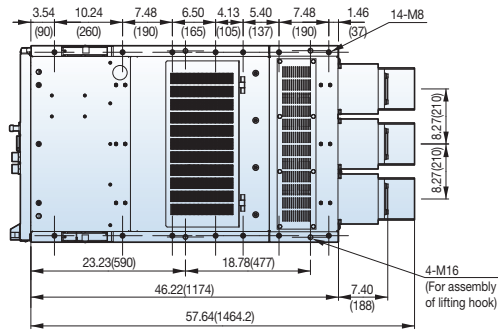

Memo

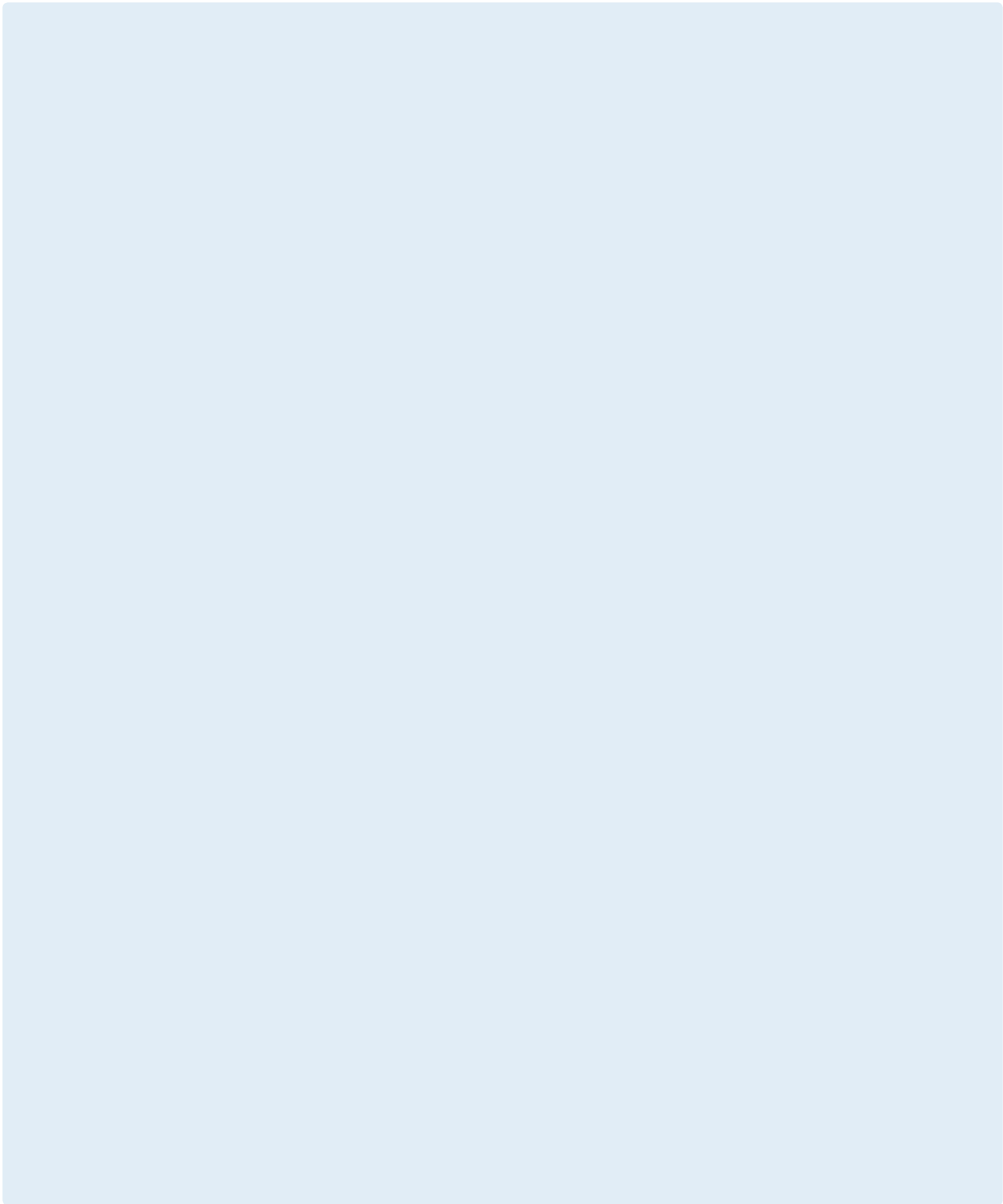

Susol UVM

Drawout type
(Draw in/out by using screw)



Contents

▪ Ratings and description	54
▪ Selection guide of circuit breaker type	55
▪ Order form	57
▪ Dimensions	59

Ratings and description

UVM type, Drawout type



UVM-05H / UVM-15H

Circuit breaker type		UVM-05H				UVM-15H			
Rated voltage	Ur (kV)	4.76				15			
Rated withstand voltage	Power frequency (1min)	19				36			
	Lightening impulse (1.2×50µs)	60				95			
Rated short-circuit current	Isc (kA)	25	25	31.5	31.5	25	25	31.5	31.5
Rated normal current	Ir (A)	1200	2000	1200	2000	1200	2000	1200	2000
Rated frequency	fr (Hz)	60				60			
Rated short-circuit making current	Ip (kA) at 60 Hz	65	65	81.9	81.9	65	65	81.9	81.9
Rated short-time withstand current	Ik (kA)	25				25			
	3sec	●	●	●	●	●	●	●	●
Operating sequence	O - 0.3s - CO - 15s - CO	●	●	●	●	●	●	●	●

Technical data

Opening time	Less than 0.04 sec	
Rated breaking time	3 Cycle	
No-load closing time	Less than 0.06 sec	
Type test class	Mechanical endurance	M2 (10,000)
	Electrical endurance	Reference standard (page 201)
	Apacitance current switching	C2
Operate temperature	Low	-40 °C
	High	40 °C

Description for circuit breaker type

UVM type, Drawout type

Withdrawal VCB, Cradle for MCSG

UVM	15	H	32	A	12
Basic model name	Rated voltage (kV)	Version	Interrupting current (kA)	Phase distance/Compatibility	Rated current (A)
UVM Susol VCB	05 4.76 15 15	H H type drawout (for MCSG)	25 25 32 31.5	A 7"(178mm) C 10"(254mm)	12 1200A 20 2000A

Selection table of circuit breaker type

Select withdrawal VCB/Cradle with same horizontal line.

Ur [kV]	Isc [kA]	Ir [A]		Type of circuit breaker	Weight [kg]	Outline dimension H×W×D [mm]	Dimension page
		p = 178	p = 254				
4.76	25	1200 2000		UVM-05H25A12	100	677×554×732.7	59
				UVM-05H25A20	130	677×554×732.7	61
		1200 2000		UVM-05H25C12 UVM-05H25C20	120 150	677×808×732.7 677×808×732.7	59 61
	31.5	1200 2000		UVM-05H32A12	100	677×554×732.7	60
				UVM-05H32A20	130	677×554×732.7	61
		1200 2000		UVM-05H32C12 UVM-05H32C20	120 150	677×808×732.7 677×808×732.7	60 61
15	25	1200 2000		UVM-15H25A12	100	677×554×732.7	59
				UVM-15H25A20	130	677×554×732.7	61
		1200 2000		UVM-15H25C12 UVM-15H25C20	120 150	677×808×732.7 677×808×732.7	59 61
	31.5	1200 2000		UVM-15H32A12	100	677×554×732.7	60
				UVM-15H32A20	130	677×554×732.7	61
		1200 2000		UVM-15H32C12 UVM-15H32C20	120 150	677×808×732.7 677×808×732.7	60 61

Selection guide of circuit breaker type

Description for Cradle

UVM type, Drawout type



H type

UVC	M	15	H	32	A	12					
Basic model name		Rated voltage (kV)		Version		Interrupting current (kA)		Phase distance/Compatibility		Rated current (A)	
UVC	M	05	4.76	L	MCSG Cradle type	25	25	A	7"(178mm)	12	1200A
		15	15	C	Compact type drawout (for MCSG)	32	31.5	C	10"(254mm)	20	2000A
				H	H type drawout (for MCSG)						

Selection table of cradle

Arc resistance	Type of cradle	Outline dimension H×W×D [mm]	Dimension page
-	UVC	920×660×1201	62
-	UVC	920×660×1201	70
-	UVC	920×914×1201	63
-	UVC	920×914×1201	71
-	UVC	920×660×1201	62
-	UVC	920×660×1201	70
-	UVC	920×914×1201	63
-	UVC	920×914×1201	71
-	UVC	920×660×1201	62
-	UVC	920×660×1201	70
-	UVC	920×914×1201	63
-	UVC	920×914×1201	71
-	UVC	920×660×1201	62
-	UVC	920×660×1201	70
-	UVC	920×914×1201	63
-	UVC	920×914×1201	71
-	UVC	1060×660×1201	64
-	UVC	1060×660×1201	66
-	UVC	1060×914×1201	65
-	UVC	1060×914×1201	67
-	UVC	1060×660×1201	64
-	UVC	1060×660×1201	66
-	UVC	1060×914×1201	65
-	UVC	1060×914×1201	67
-	UVC	1060×660×1201	64
-	UVC	1060×660×1201	66
-	UVC	1060×914×1201	65
-	UVC	1060×914×1201	67
-	UVC	1060×660×1455	68
-	UVC	1060×660×1455	72
-	UVC	1060×914×1455	69
-	UVC	1060×914×1455	73
-	UVC	1060×660×1455	68
-	UVC	1060×660×1455	72
-	UVC	1060×914×1455	69
-	UVC	1060×914×1455	73
-	UVC	1060×660×1455	68
-	UVC	1060×660×1455	72
-	UVC	1060×914×1455	69
-	UVC	1060×914×1455	73

Full description for circuit breaker

UVM type, Drawout type

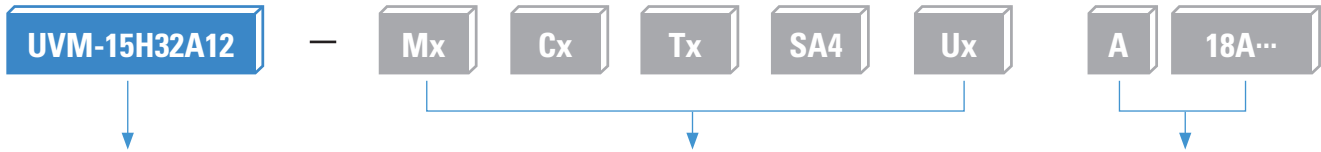

1 Type of circuit breaker
(select from the previous page)

2 Control source and auxiliary contacts & connector

3 Accessories

※ In case of selecting 3 Accessories, only type Symbol 'A' once. (ex. A18A)

Order form for circuit breaker

Please select only one of the items on the same horizontal line. (* Required selection)

UVM, VCB, Drawout type

(no extra charge extra charge)

1 Type of VCB from selection table*

ea

2 Control source

Motor* (Mx)								page 154	
<input type="radio"/> M0	<input type="radio"/> M1	<input type="radio"/> M2	<input type="radio"/> M3	<input type="radio"/> M4	<input type="radio"/> M5	<input type="radio"/> M6	<input type="radio"/> M7	<input type="radio"/> M8	
Without motor		DC 110V	DC 200V ~ 250V	DC 125V	DC 24V ~ 30V	DC 48V ~ 60V	AC 48V	AC 100V ~ 130V	AC 200V ~ 250V
Closing coil* (Cx)								page 155	
<input type="radio"/> C0	<input type="radio"/> C1	<input type="radio"/> C2	<input type="radio"/> C3	<input type="radio"/> C4	<input type="radio"/> C5	<input type="radio"/> C6	<input type="radio"/> C7	<input type="radio"/> C8	
Without CC		DC 110V	DC 200V ~ 250V	DC 125V	DC 24V ~ 30V	DC 48V ~ 60V	AC 48V	AC 100V ~ 130V	AC 200V ~ 250V
Shunt trip coil* (Tx)								page 156	
<input type="radio"/> T0	<input type="radio"/> T1	<input type="radio"/> T2	<input type="radio"/> T3	<input type="radio"/> T4	<input type="radio"/> T5	<input type="radio"/> T6	<input type="radio"/> T7	<input type="radio"/> T8	
Without SHT		DC 110V	DC 200V ~ 250V	DC 125V	DC 24V ~ 30V	DC 48V ~ 60V	AC 48V	AC 100V ~ 130V	AC 200V ~ 250V
Auxiliary contacts & Connector type*								page 159	
<input type="radio"/> SC2 (4a4b Standard type, Auto-con type)				<input type="radio"/> SC4 (10a10b Standard type, Auto-con type)					
Under Voltage Release (Ux)								page 160	
<input type="radio"/> U0*	<input type="checkbox"/> U1	<input type="checkbox"/> U2	<input type="checkbox"/> U3	<input type="checkbox"/> U4	<input type="checkbox"/> U5	<input type="checkbox"/> U6	<input type="checkbox"/> U7	<input type="checkbox"/> U8	
Without UVT		DC 110V	DC 200V ~ 250V	DC 125V	DC 24V ~ 30V	DC 48V ~ 60V	AC 48V	AC 100V ~ 130V	AC 200V ~ 250V
※ Even without UVT, U0 must be selected to make VCB ordering code and description									
Note) In case of DC24V control source(M4, C4, T4, U4), it is recommended to be used through Rated Control Voltage.									

3 Accessories

Combination table

U0	1	
U1-8		1
A1 & A2	1	

Available no. of Aux. contact

Symbol	10a10b
Standard	10 NO, 10 NC
with A1	9 NO, 9 NC
with A2	9 NO, 8 NC

Secondary shunt trip coil		page 157
<input type="checkbox"/> A1 (Secondary shunt trip coil)		
※ In case of selecting A1, maximum auxiliary contacts are 9a9b		
<input type="checkbox"/> A2 (Secondary shunt trip coil monitoring contact)		
※ In case of selecting A2, maximum auxiliary contacts are 9a8b		
Keylock		page 162
<input type="checkbox"/> A7 (Keylock(Individual key))		
<input type="checkbox"/> AM (Kirk key, CAMLOCK type)		
<input type="checkbox"/> AG (Keylock(Same key))		
<input type="checkbox"/> AN (Kirk key, CN-22 type)		
<input type="checkbox"/> AP (Kirk key, Double CAMLOCK type)		
Button padlock*		page 163
<input type="checkbox"/> A8 (Button padlock)		
<input type="checkbox"/> AX (Button padlock in open)		
MOC operator*		page 166
<input type="checkbox"/> AE		
Auxiliary wheels (Direct roll-in)		page 167
<input type="checkbox"/> AS		

Separately sold accessories

CTU (Coil test unit)	<input type="checkbox"/> 73873171221 CTU (Coil test unit)	page 169
CTD (Condenser trip device)	<input type="checkbox"/> 76113143001 CTD (Condenser trip device) AC/DC 100V, 110V <input type="checkbox"/> 76113143002 CTD (Condenser trip device) AC/DC 200V, 220V	page 170
UDC (UVT delay controller)	<input type="checkbox"/> 52773171282 UDC (UVT delay controller) AC/DC 100~130V <input type="checkbox"/> 52773171283 UDC (UVT delay controller) AC/DC 200~250V <input type="checkbox"/> 52773171281 UDC (UVT delay controller) DC 48~60V and AC 48V	page 171

Order form

Full description for cradle

UVM type, Drawout type

UVCM-05L25A12

A **13567A**

① Type of cradle
(select from the previous page)

③ Accessories

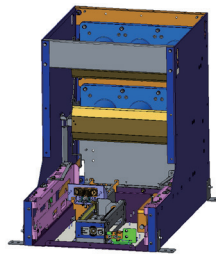

L type



C type



H type

Order form for cradle

Please select only one of the items on the same horizontal line. (* Required selection)

UVM, VCB, Drawout type

(○ no extra charge □ extra charge)

① Type of Cradle from selection table*		Quantity	ea
② Control source			
Lead wire*			page 164
<input type="checkbox"/> A1 (4a4b)	<input type="checkbox"/> A2 (10a10b)		
Standard set (Shutter padlock, TOC, MOC)*			page 172 ~ 173
<input type="checkbox"/> A3 (6a6b(MOC,TOC))	<input type="checkbox"/> A4 (12a12b(MOC,TOC))		
※ In case of selecting Remote Racking System, Maximum contacts of MOC are 4a4b.		※ In case of selecting Remote Racking System, Maximum contacts of MOC are 10a10b.	
Padlock (Only for H type cradle)			page 173
<input type="checkbox"/> A5			
Door (Only for H type cradle)			page 174
<input type="checkbox"/> A6			
Door interlock (Only for H type cradle)			page 175
<input type="checkbox"/> A7			
Kirk key interlock (Only for H type cradle)			page 174
<input type="checkbox"/> A9			
※ In case of selecting Remote Racking System, A9 must be selected to make cradle ordering code and description. The Kirk-key is not provided separately.			
Remote racking system (Only for H type cradle)			page 177
<input type="checkbox"/> AA (AC120V, Without OPEN, CLOSE Function)	<input type="checkbox"/> AB (AC240V, Without OPEN, CLOSE Function)		
<input type="checkbox"/> AC (DC125V, Without OPEN, CLOSE Function)	<input type="checkbox"/> AD (DC250V, Without OPEN, CLOSE Function)		
<input type="checkbox"/> AE (AC120V, With OPEN, CLOSE Function)	<input type="checkbox"/> AF (AC240V, With OPEN, CLOSE Function)		
<input type="checkbox"/> AG (DC125V, With OPEN, CLOSE Function)	<input type="checkbox"/> AH (DC250V, With OPEN, CLOSE Function)		

Separately sold accessories

Racking In/Out handle		page 179 ~ 180
<input type="checkbox"/> 55223172411 (Normal type for L-cradle)	<input type="checkbox"/> 55223181002 (Universal type for 1200/2000/3000A Remote Racking System)	
<input type="checkbox"/> 55223181001 (Universal type for 1200/2000/3000A H Cradle)		
Extension rail		page 183
<input type="checkbox"/> 59023181003		

4.76/15kV, 25kA, 1200A

UVM type, Drawout type

Type of circuit breaker

- UVM-05H25A12
- UVM-15H25A12

[Unit: inch(mm)]

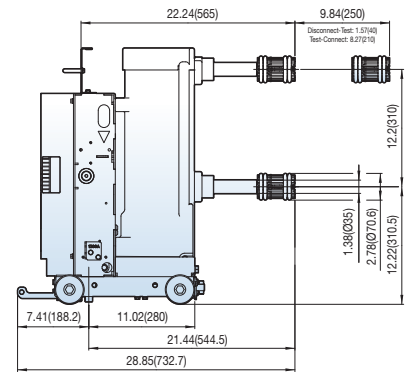
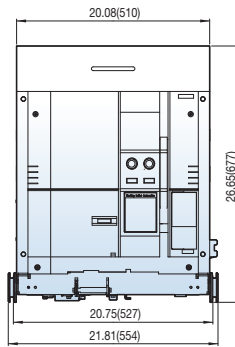
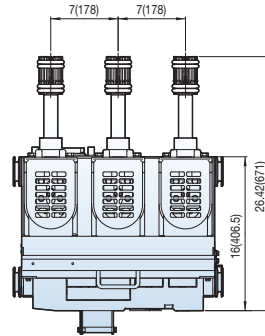

Type of circuit breaker

- UVM-05H25C12
- UVM-15H25C12

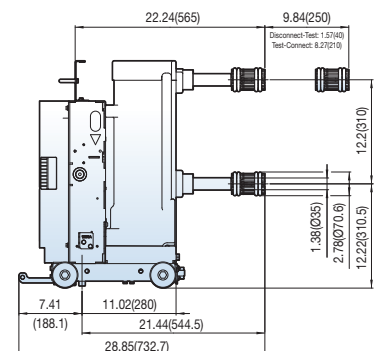
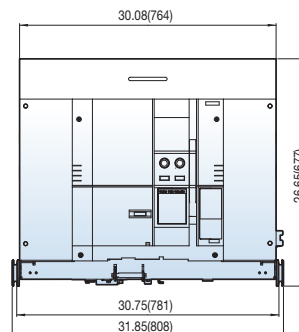
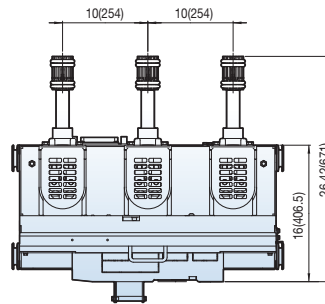

Dimensions

4.76/15kV, 31.5kA, 1200A

UVM type, Drawout type

Type of circuit breaker

UVM-05H32A12
UVM-15H32A12

[Unit: inch(mm)]

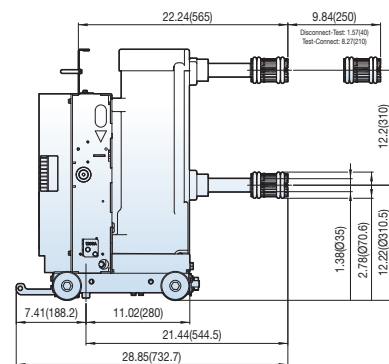
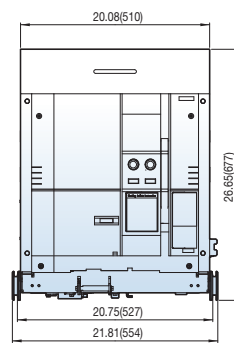
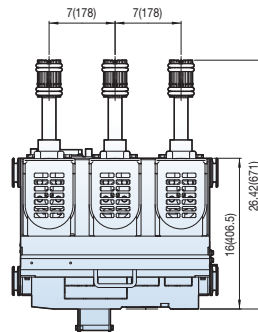

Type of circuit breaker

UVM-05H32C12
UVM-15H32C12

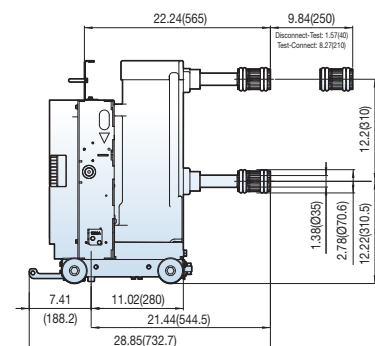
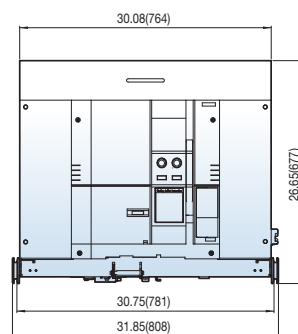
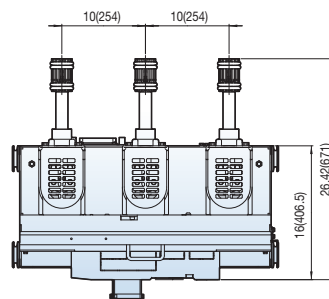

4.76/15kV, 25/31.5kA, 2000A

UVM type, Drawout type

[Unit: inch(mm)]

Type of circuit breaker

- UVM-05H25A20
- UVM-05H32A20
- UVM-15H25A20
- UVM-15H32A20

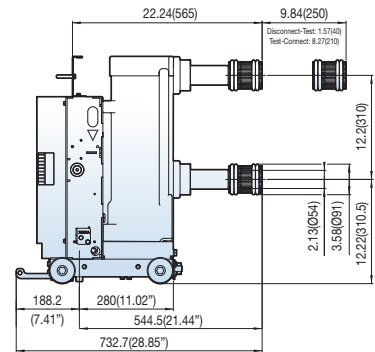
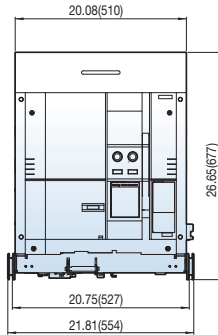
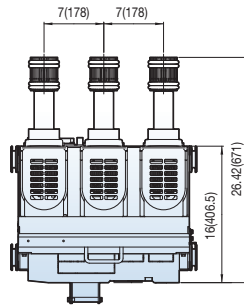

Type of circuit breaker

- UVM-05H25C20
- UVM-05H32C20
- UVM-15H25C20
- UVM-15H32C20

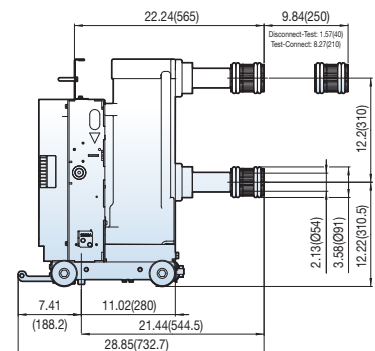
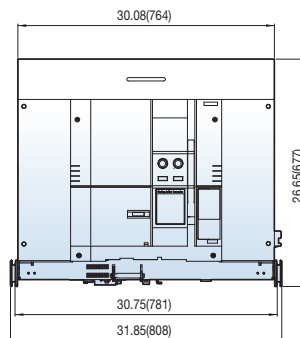
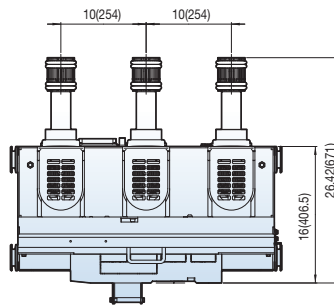

Dimensions

4.76/15kV, 25/31.5kA, 1200A

UVM type, Drawout type

Type of cradle

- UVCM-05L25A12
- UVCM-05L32A12
- UVCM-15L25A12
- UVCM-15L32A12

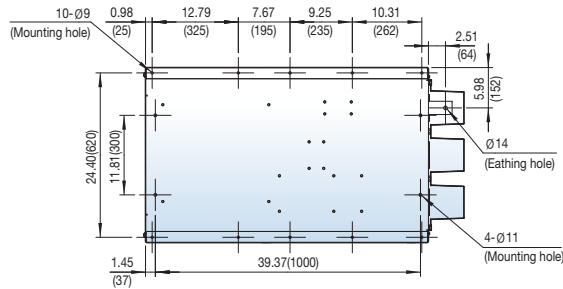
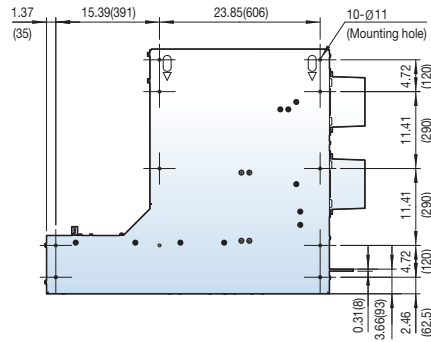
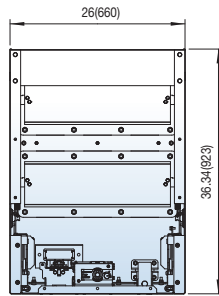
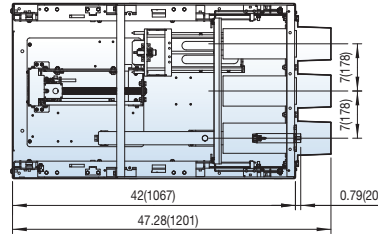
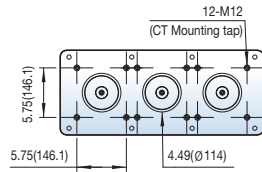

[Unit: inch(mm)]

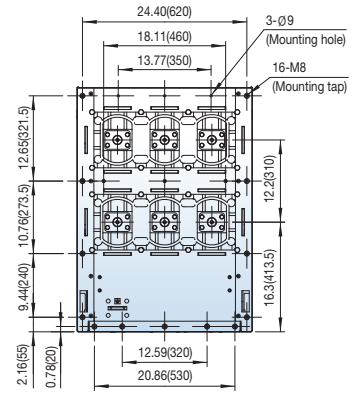
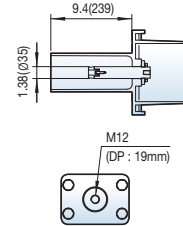

4.76/15kV, 25/31.5kA, 1200A

UVM type, Drawout type

Type of cradle

- UVM-05L25C12
- UVM-05L32C12
- UVM-15L25C12
- UVM-15L32C12

[Unit: inch(mm)]

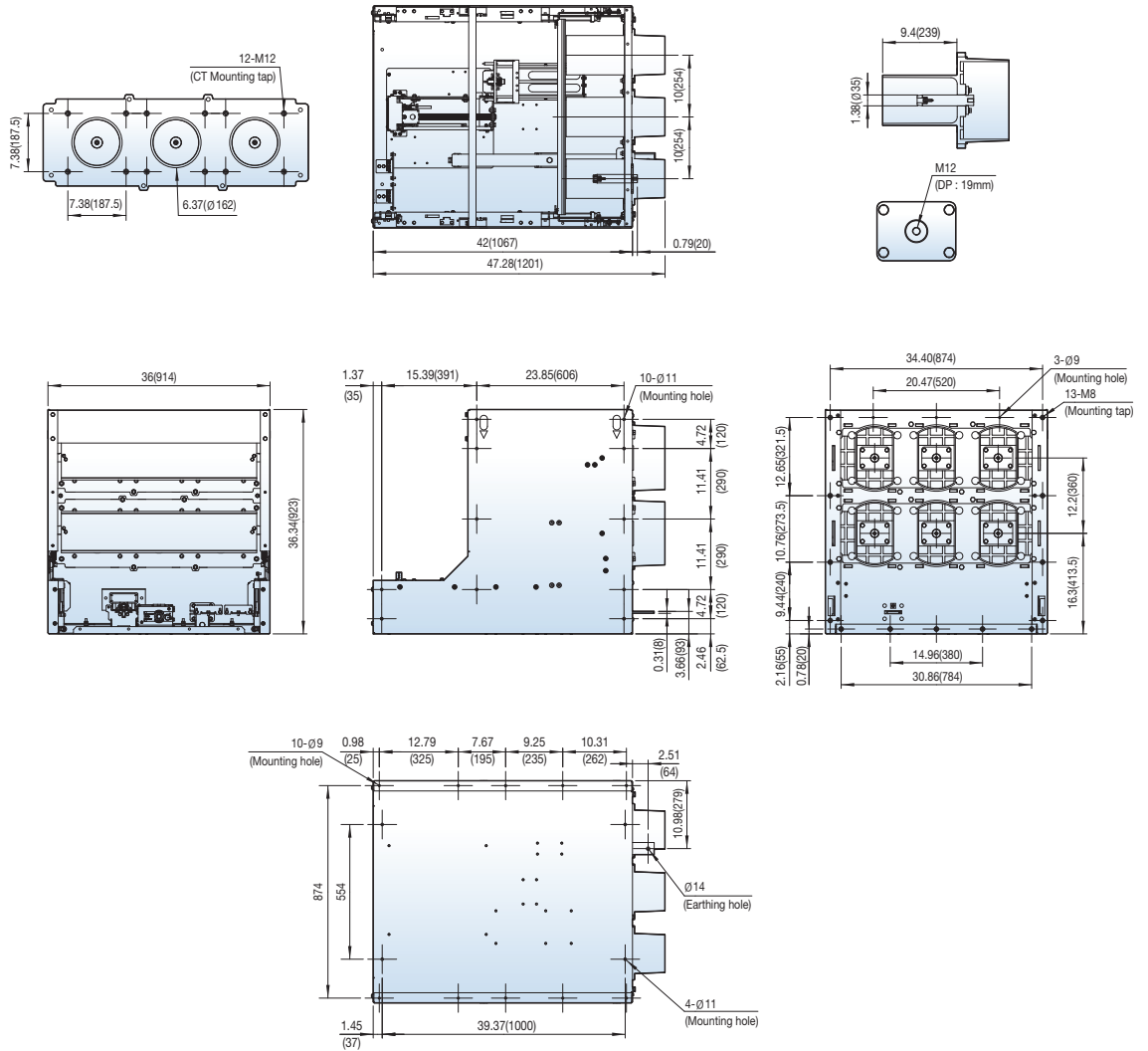

Dimensions

4.76/15kV, 25/31.5kA, 1200A

UVM type, Drawout type

Type of cradle

- UVCM-05C25A12
- UVCM-05C32A12
- UVCM-15C25A12
- UVCM-15C32A12

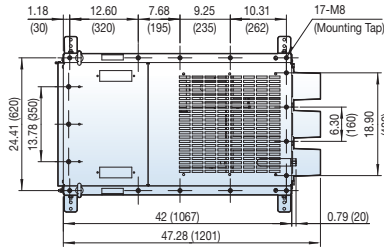
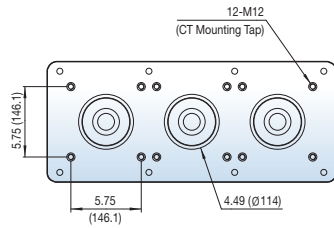

[Unit: inch(mm)]

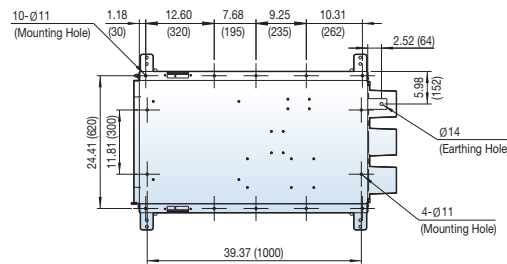
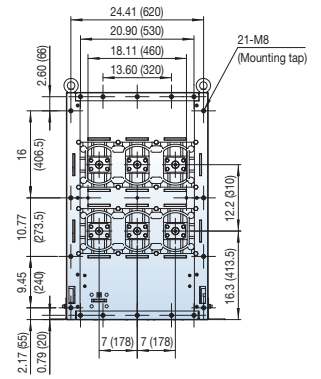
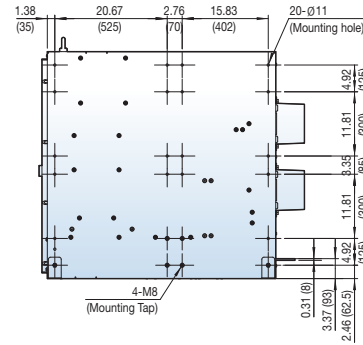
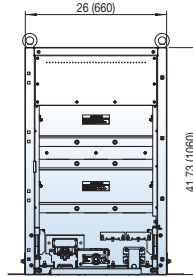
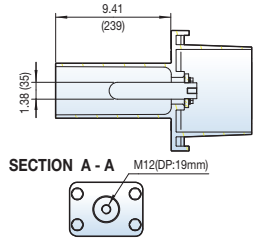

4.76/15kV, 25/31.5kA, 1200A

UVM type, Drawout type

Type of cradle

- UVCN-05C25C12
- UVCN-05C32C12
- UVCN-15C25C12
- UVCN-15C32C12

[Unit: inch(mm)]

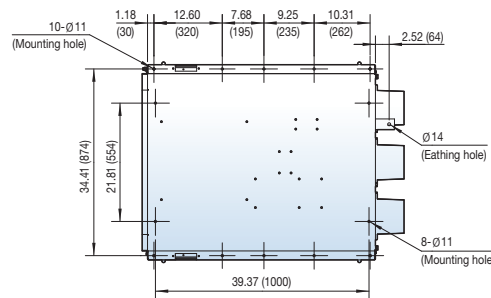
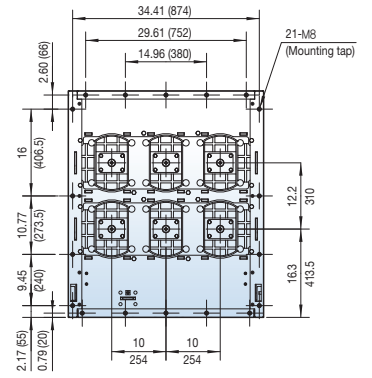
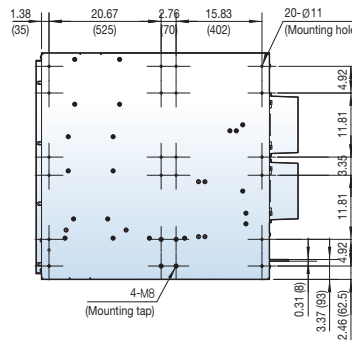
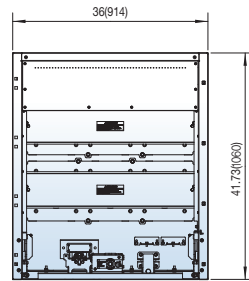
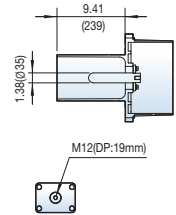
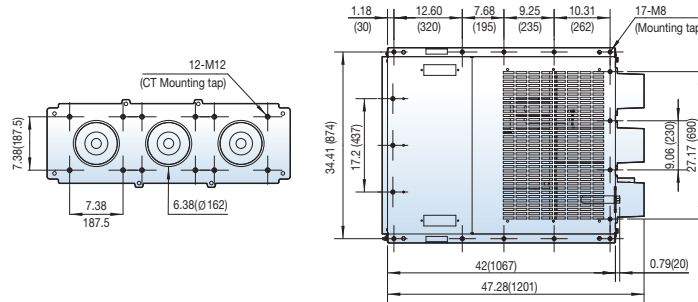

Dimensions

4.76/15kV, 25/31.5kA, 2000A

UVM type, Drawout type

Type of cradle

- UVCM-05C25A20
- UVCM-05C32A20
- UVCM-15C25A20
- UVCM-15C32A20

[Unit: inch(mm)]

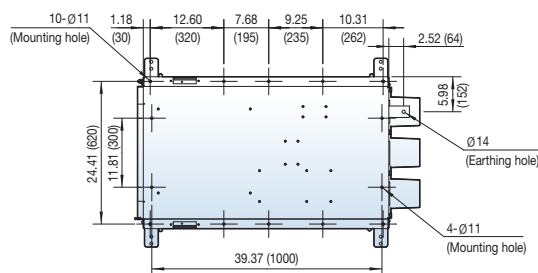
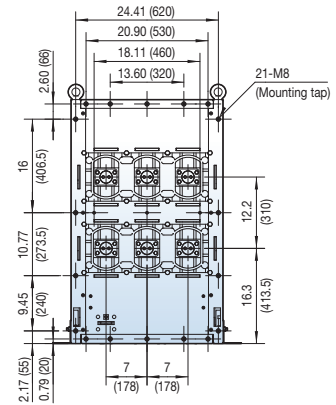
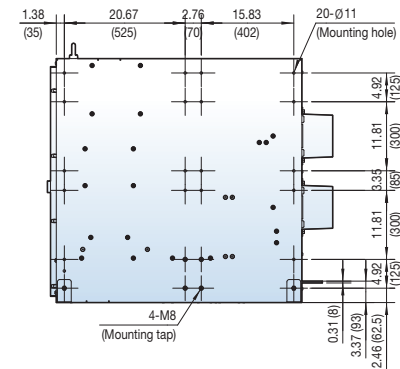
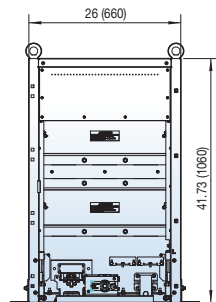
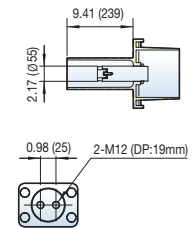
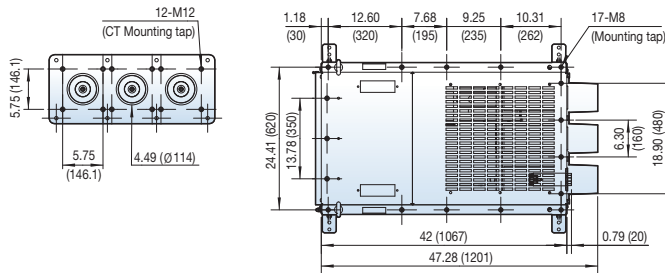

4.76/15kV, 25/31.5kA, 2000A

UVM type, Drawout type

Type of cradle

- UVCM-05C25C20
- UVCM-05C32C20
- UVCM-15C25C20
- UVCM-15C32C20

[Unit: inch(mm)]

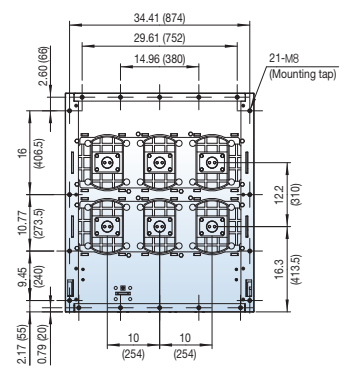
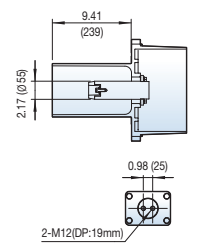
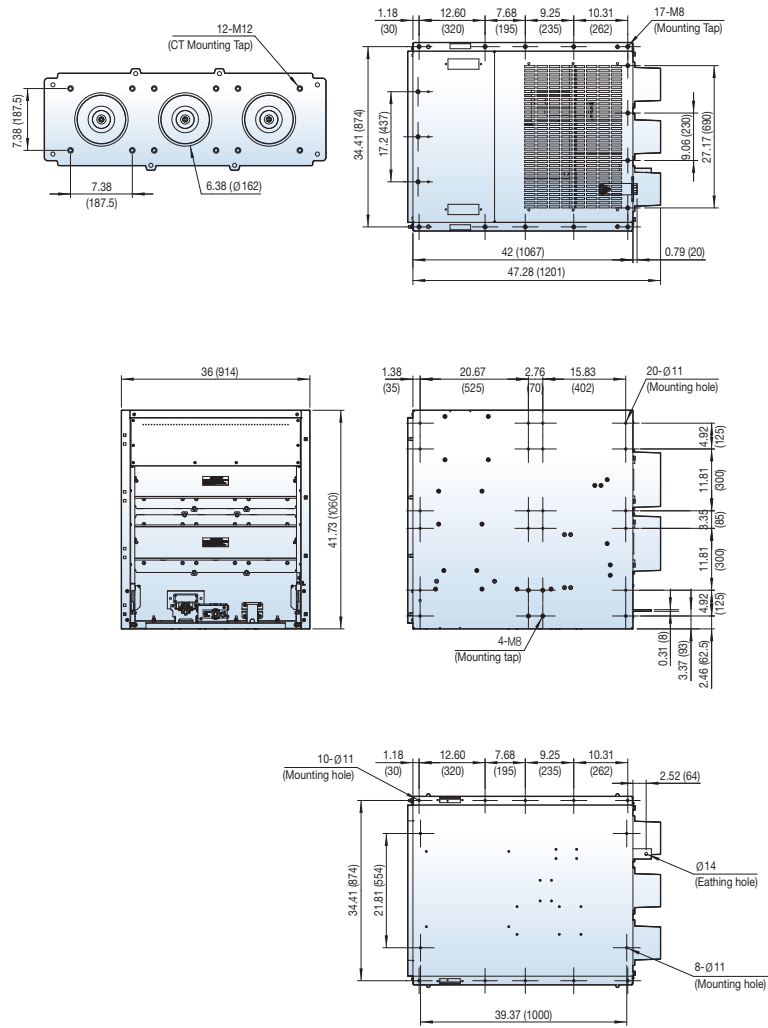

Dimensions

4.76/15kV, 25/31.5kA, 1200A

UVM type, Drawout type

Type of cradle

- UVCM-05H25A12
- UVCM-05H32A12
- UVCM-15H25A12
- UVCM-15H32A12

[Unit: inch(mm)]

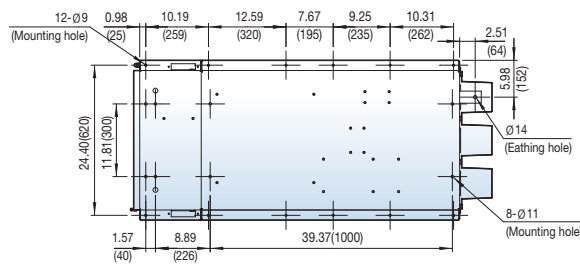
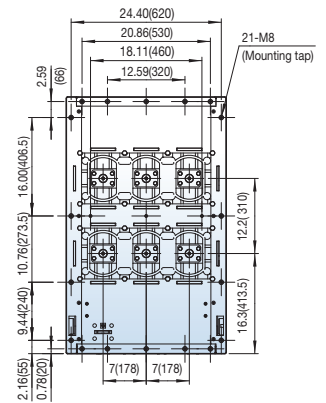
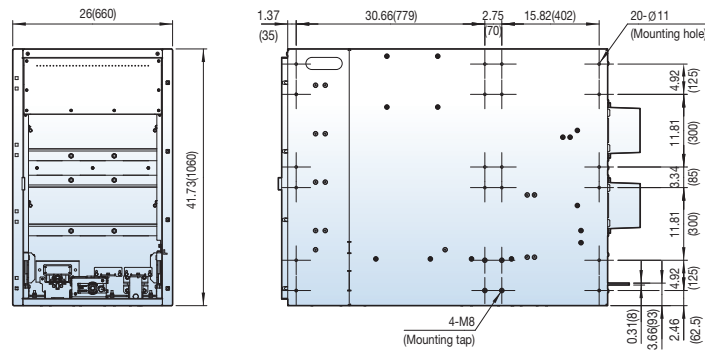
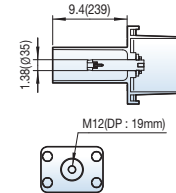
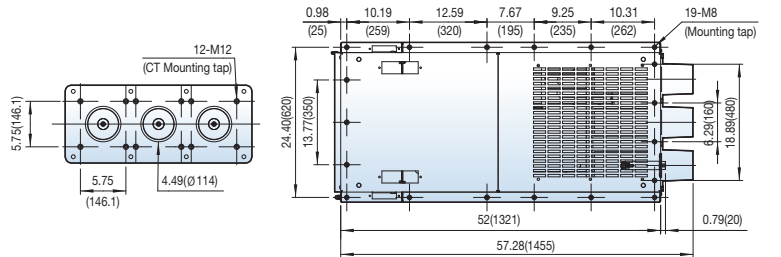

4.76/15kV, 25/31.5kA, 1200A

UVM type, Drawout type

Type of cradle

- UVCM-05H25C12
- UVCM-05H32C12
- UVCM-15H25C12
- UVCM-15H32C12

[Unit: inch(mm)]

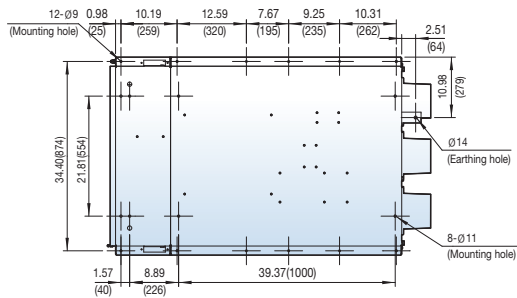
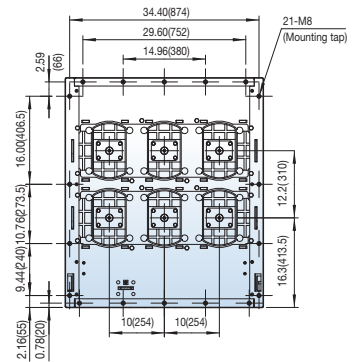
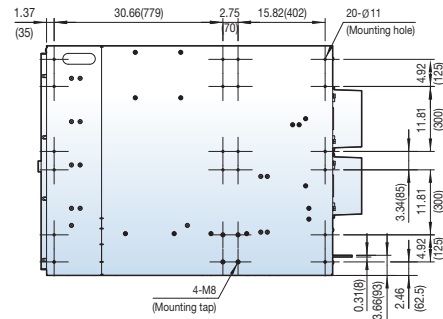
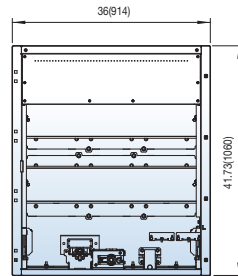
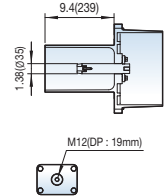
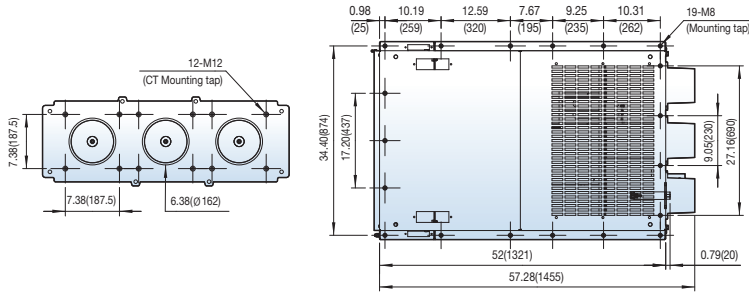

Dimensions

4.76/15kV, 25/31.5kA, 2000A

UVM type, Drawout type

Type of cradle

- UVCM-05L25A20
- UVCM-05L32A20
- UVCM-15L25A20
- UVCM-15L32A20

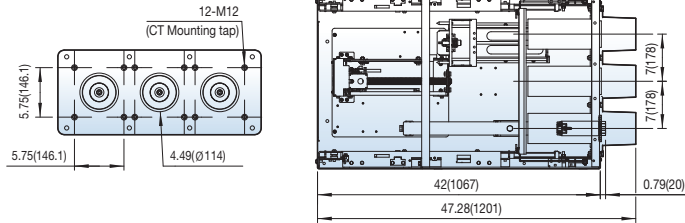

[Unit: inch(mm)]

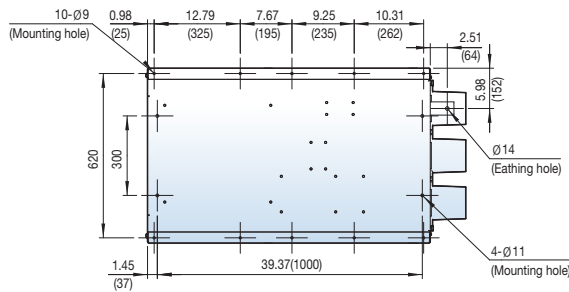
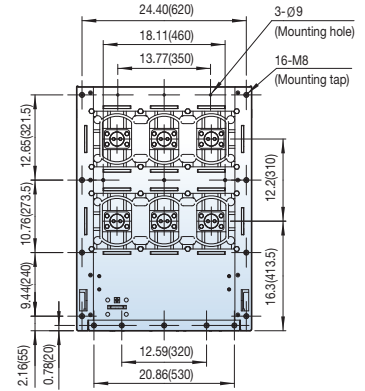
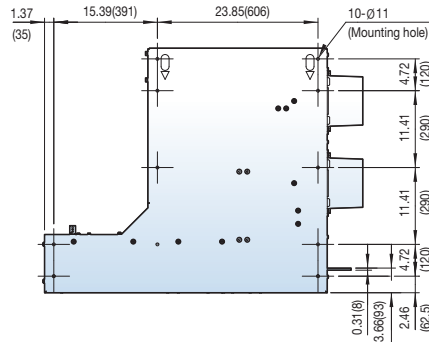
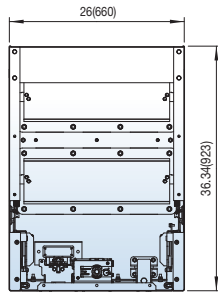
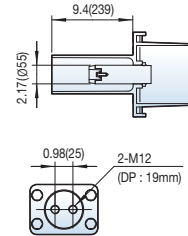

4.76/15kV, 25/31.5kA, 2000A

UVM type, Drawout type

Type of cradle

- UVCM-05L25C20
- UVCM-05L32C20
- UVCM-15L25C20
- UVCM-15L32C20

[Unit: inch(mm)]

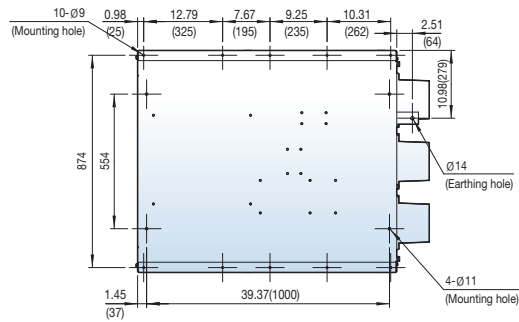
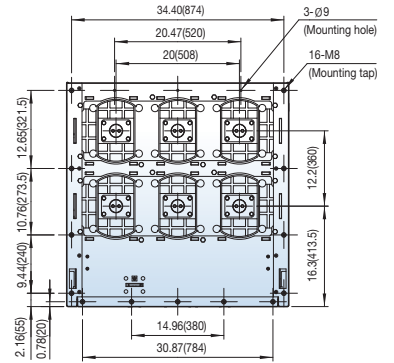
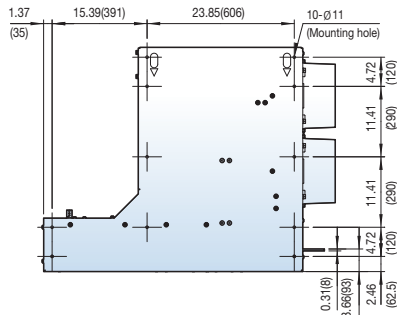
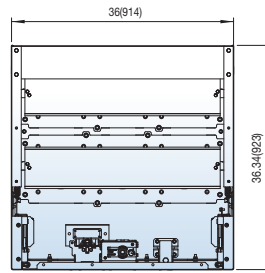
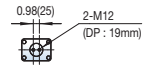
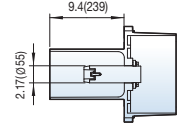
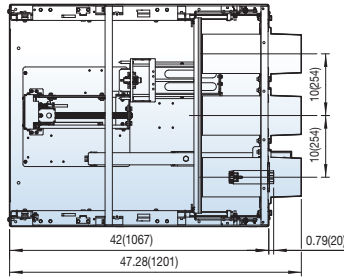
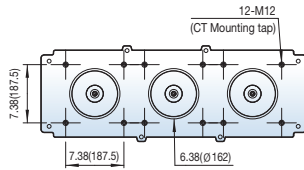

Dimensions

4.76/15kV, 25/31.5kA, 2000A

UVM type, Drawout type

Type of cradle

- UVCM-05H25A20
- UVCM-05H32A20
- UVCM-15H25A20
- UVCM-15H32A20

[Unit: inch(mm)]

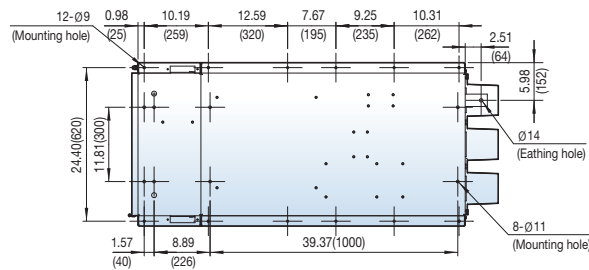
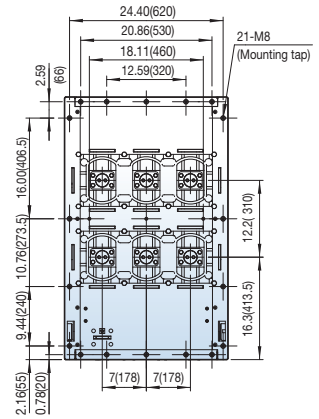
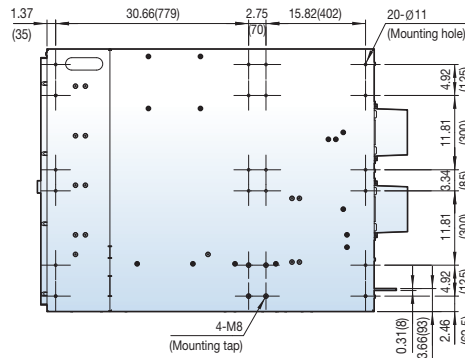
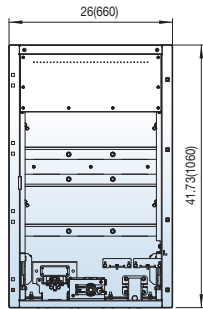
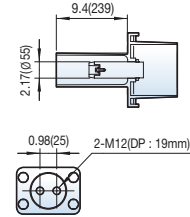
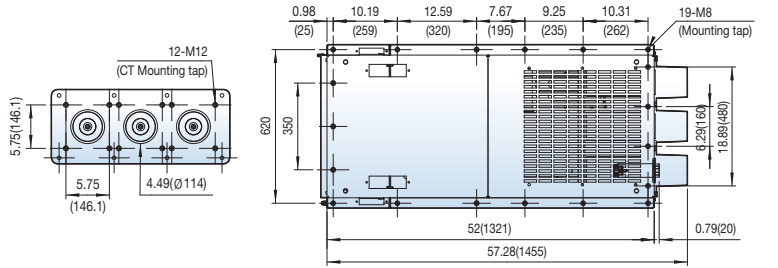

4.76/15kV, 25/31.5kA, 2000A

UVM type, Drawout type

Type of cradle

- UVCM-05H25C20
- UVCM-05H32C20
- UVCM-15H25C20
- UVCM-15H32C20

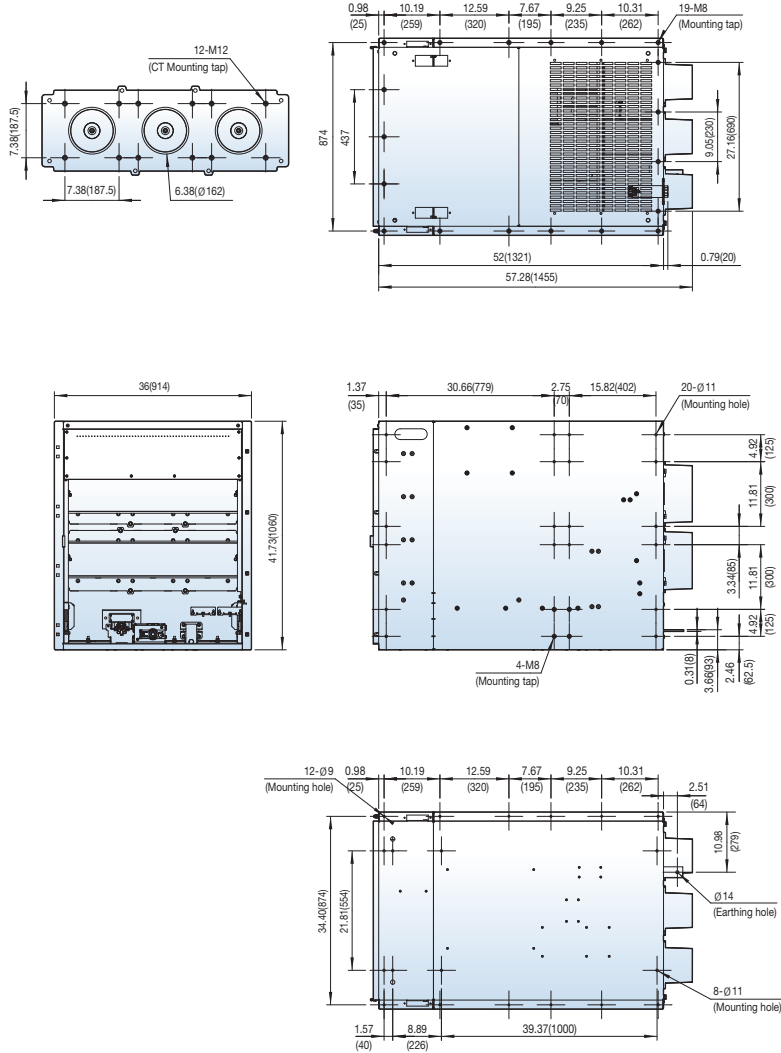

[Unit: inch(mm)]

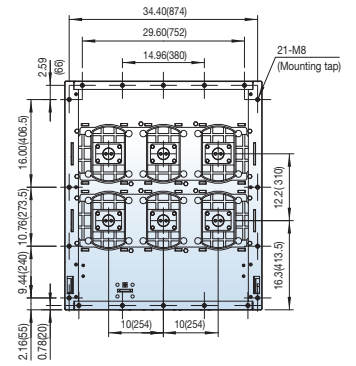
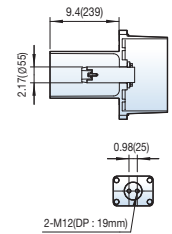

Memo

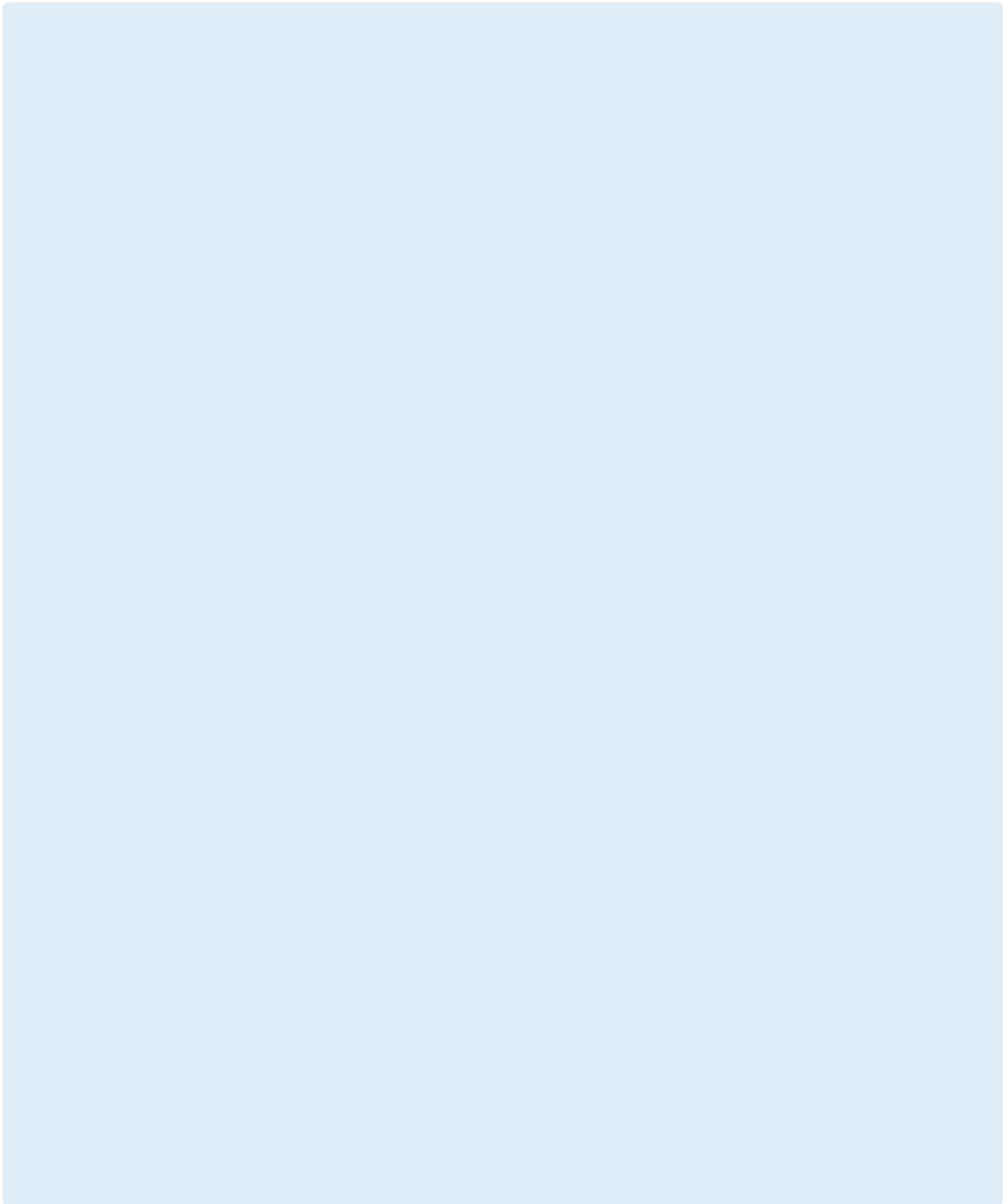

Susol UVH

Drawout Type
(Draw in/out by using screw)



Contents

▪ Ratings and description	76
▪ Selection guide of circuit breaker type	78
▪ Order form	83
▪ Dimensions	75

Ratings and description

UVH type, Drawout type



Circuit breaker type		UVH-05H											
Rated voltage	Ur (kV)	4.76											
Rated withstand voltage	Power frequency (1min)	Ud (kV) 19											
	Lightening impulse (1.2×50µs)	Up (kV) 60											
Rated short-circuit current	Isc (kA)	25	25	31.5	31.5	40	40	40	40	50	50	50	50
Rated normal current	Ir (A)	3000	4000	3000	4000	1200	2000	3000	4000	1200	2000	3000	4000
Rated frequency	fr (Hz)	60											
Rated short-circuit making current	Ip (kA) at 50 Hz	-											
	Ip (kA) at 60 Hz	65	65	81.9	81.9	104	104	104	104	130	130	130	130
Rated short-time withstand current	Ik (kA)	25	25	31.5	31.5	40	40	40	40	50	50	50	50
	3sec	●	●	●	●	●	●	●	●	●	●	●	●
Operating sequence	O - 0.3s - CO - 15s - CO	●	●	●	●	●	●	●	●	●	●	●	●



Circuit breaker type		UVH-15H											
Rated voltage	Ur (kV)	15											
Rated withstand voltage	Power frequency (1min)	Ud (kV) 36											
	Lightening impulse (1.2×50µs)	Up (kV) 95											
Rated short-circuit current	Isc (kA)	25	25	31.5	31.5	40	40	40	40	50	50	50	50
Rated normal current	Ir (A)	3000	4000	3000	4000	1200	2000	3000	4000	1200	2000	3000	4000
Rated frequency	fr (Hz)	60											
Rated short-circuit making current	Ip (kA) at 50 Hz	-											
	Ip (kA) at 60 Hz	65	65	81.9	81.9	104	104	104	104	130	130	130	130
Rated short-time withstand current	Ik (kA)	25	25	31.5	31.5	40	40	40	40	50	50	50	50
	3sec	●	●	●	●	●	●	●	●	●	●	●	●
Operating sequence	O - 0.3s - CO - 15s - CO	●	●	●	●	●	●	●	●	●	●	●	●

Technical data

Opening time	Less than 0.04 sec	
Rated breaking time	3 Cycle	
No-load closing time	Less than 0.06 sec	
Type test class	Mechanical endurance	M2 (10,000)
	Electrical endurance	Reference standard (page 201)
	Apacitance current switching	C2
Operate temperature	Low	-40 °C
	High	40 °C

UVH type, Drawout type



Circuit breaker type		UVH-05H									
Rated voltage	Ur (kV)	27									
Rated withstand voltage	Power frequency (1min)	Ud (kV)	60								
	Lightening impulse (1.2×50μs)	Up (kV)	125								
Rated short-circuit current	Isc (kA)	25	31.5				40				
Rated normal current	Ir (A)	2500	2750	1200	2000	2500	2750	1200	2000	2500	2750
Rated frequency	fr (Hz)	60	60	60	60	60	60	60	60	60	60
Rated short-circuit making current	I _p (kA) at 50 Hz	-	-	-	-	-	-	-	-	-	-
	I _p (kA) at 60 Hz	65	65	81.9	81.9	81.9	81.9	104	104	104	104
Rated short-time withstand current	I _k (kA)	25	25	31.5	31.5	31.5	31.5	40	40	40	40
	3sec	●	●	●	●	●	●	●	●	●	●
Operating sequence	O - 0.3s - CO - 15s - CO	●	●	●	●	●	●	●	●	●	●

UVH-38H (ANSI Type Test)

Circuit breaker type		UVH-38H				
Rated voltage	Ur (kV)	38				
Rated withstand voltage	Power frequency (1min)	Ud (kV)	80			
	Lightening impulse (1.2×50μs)	Up (kV)	170			
Rated short-circuit current	Isc (kA)	31.5	31.5		40	40
Rated normal current	Ir (A)	1200	2000		1200	2000
Rated frequency	fr (Hz)	60	60		60	60
Rated short-circuit making current	I _p (kA) at 50 Hz	-	-		-	-
	I _p (kA) at 60 Hz	81.9	81.9		104	104
Rated short-time withstand current	I _k (kA)	31.5	31.5		40	40
	3sec	●	●		●	●
Operating sequence	O - 0.3s - CO - 15s - CO	●	●		●	●

Technical data

Opening time	Less than 0.04 sec	
Rated breaking time	3 Cycle	
No-load closing time	Less than 0.06 sec	
Type test class	Mechanical endurance	M2 (10,000)
	Electrical endurance	Reference standard (page 201)
	Apacitance current switching	C2
Operate temperature	Low	- 40 °C
	High	40 °C

Selection guide of circuit breaker type

Description for circuit breaker type

UVH type, Drawout type

UVH	15	H	40	A	12
Basic model name	Rated voltage (kV)	Version	Interrupting current (kA)	Phase distance/Compatibility	Rated current (A)
UVH Susol VCB	05 4.76 15 15	H H type drawout (for MCSG)	25 25 32 31.5 40 40 50 50	A 7"(178mm) C 10"(254mm) L 12.59"(320mm)	12 1200A 20 2000A 30 3000A* 40 4000A*
* 3000/4000A have only 1 phase distance 3000A: 10"(254mm) 4000A: 12.59"(320mm)					
UVH	27	H	40	C	12
Basic model name	Rated voltage (kV)	Version	Interrupting current (kA)	Phase distance/Compatibility	Rated current (A)
UVH Susol VCB	27 27	H H type drawout (for MCSG)	25 25 32 31.5 40 40	C 10"(254mm)	12 1200A 20 2000A 25 2500A 28 2750A
UVH	38	H	40	E	12
Basic model name	Rated voltage (kV)	Version	Interrupting current (kA)	Phase distance/Compatibility	Rated current (A)
UVH Susol VCB	38 38	H H type drawout (for MCSG)	32 31.5 40 40	E 11.8"(300mm)	12 1200A 20 2000A

Selection table of circuit breaker type

Select withdrawal VCB/Cradle with same horizontal line.

Ur [kV]	Isc [kA]	Ir [A]				Type of circuit breaker	Weight [kg]	Outline dimension H×W×D [mm]	Dimension page
		p = 178	p = 254	p = 300	p = 320				
4.76	25		3000		4000	UVH-05H25C30	260	806×809×732.7	88
						UVH-05H25L40	440	1002×1039×726.7	88
	31.5		3000		4000	UVH-05H32C30	260	806×809×732.7	88
						UVH-05H32L40	440	1002×1039×726.7	88
	40	1200 2000	1200 2000 3000		4000	UVH-05H40A12	195	806×555×732.7	85
						UVH-05H40A20	210	806×555×732.7	87
						UVH-05H40C12	210	806×809×732.7	85
						UVH-05H40C20	225	806×809×732.7	87
						UVH-05H40C30	260	806×809×732.7	88
						UVH-05H40L40	440	1002×1039×726.7	88
	50	1200 2000	1200 2000 3000		4000	UVH-05H50A12	210	806×555×732.7	86
						UVH-05H50A20	210	806×555×732.7	87
UVH-05H50C12						225	806×809×732.7	86	
UVH-05H50C20						225	806×809×732.7	87	
UVH-05H50C30						260	806×809×732.7	88	
UVH-05H50L40						440	1002×1039×726.7	88	
15	25		3000		4000	UVH-15H25C30	260	806×809×732.7	88
						UVH-15H25L40	440	1002×1039×726.7	88
	31.5		3000		4000	UVH-15H32C30	260	806×809×732.7	88
						UVH-15H32L40	440	1002×1039×726.7	88
	40	1200 2000	1200 2000 3000		4000	UVH-15H40A12	195	806×555×732.7	85
						UVH-15H40A20	210	806×555×732.7	87
						UVH-15H40C12	210	806×809×732.7	85
						UVH-15H40C20	225	806×809×732.7	87
						UVH-15H40C30	260	806×809×732.7	88
						UVH-15H40L40	440	1002×1039×726.7	88
	50	1200 2000	1200 2000 3000		4000	UVH-15H50A12	210	806×555×732.7	86
						UVH-15H50A20	210	806×555×732.7	87
UVH-15H50C12						225	806×809×732.7	86	
UVH-15H50C20						225	806×809×732.7	87	
UVH-15H50C30						260	806×809×732.7	88	
UVH-15H50L40						440	1002×1039×726.7	88	
27	25		2500 2750			UVH-27H25C25	320	930×809×882.7	90
						UVH-27H25C28	320	930×809×882.7	90
	31.5		1200 2000 2500 2750			UVH-27H32C12	275	930×809×882.7	89
						UVH-27H32C20	275	930×809×882.7	89
						UVH-27H32C25	320	930×809×882.7	90
						UVH-27H32C28	320	930×809×882.7	90
	40		1200 2000 2500 2750			UVH-27H40C12	275	930×809×882.7	89
						UVH-27H40C20	275	930×809×882.7	89
						UVH-27H40C25	320	930×809×882.7	90
						UVH-27H40C28	320	930×809×882.7	90
38	31.5		1200 2000			UVH-38H32E12	360	1100.5×963×1001.5	91
						UVH-38H32E20	360	1100.5×963×1001.5	91
	40		1200 2000			UVH-38H40E12	360	1100.5×963×1001.5	91
						UVH-38H40E20	360	1100.5×963×1001.5	91

Selection guide of circuit breaker type

Description for Cradle

UVH type, Drawout type



H type

Basic model name		Rated voltage (kV)		Version		Interrupting current (kA)		Phase distance/Compatibility		Rated current (A)	
UVCH	Susol VCB	05	4.76	L	MCSG Cradle type	25	25	A	7"(178mm)	12	1200A
	Cradle	15	15	C	Compact type drawout (for MCSG)	32	31.5	C	10"(254mm)	20	2000A
				H	H type drawout (for MCSG)	40	40	L	12.59"(320mm)	30	3000A*
						50	50			40	4000A*
		27	27	C	Compact type drawout (for MCSG)	25	25	C	10"(254mm)	12	1200A
				H	H type drawout (for MCSG)	32	31.5			20	2000A
						40	40			25	2500A
										40	2750A
		38	38	H	H type drawout (for MCSG)	32	31.5	E	11.8"(300mm)	12	1200A
						40	40			20	2000A

* 3000/4000A have only 1 phase distance
3000A: 10"(254mm)
4000A: 12.59"(320mm)

Selection table of cradle

UVH type, L type

Arc resistance	Type of cradle	Outline dimension H×W×D [mm]	Dimension page
-	UVCH-05L25C30	1015×914×1201	110
	UVCH-05L25L40	1265×1200×1209	113
-	UVCH-05L32C30	1015×914×1201	110
	UVCH-05L32L40	1265×1200×1209	113
-	UVCH-05L40A12	1015×660×1201	92
	UVCH-05L40A20	1015×660×1201	104
-	UVCH-05L40C12	1015×914×1201	93
-	UVCH-05L40C20	1015×914×1201	105
-	UVCH-05L40C30	1015×914×1201	110
-	UVCH-05L40L40	1265×1200×1209	113
-	UVCH-05L50A12	1015×660×1201	98
	UVCH-05L50A20	1015×660×1201	104
-	UVCH-05L50C12	1015×914×1201	99
-	UVCH-05L50C20	1015×914×1201	105
-	UVCH-05L50C30	1015×914×1201	110
-	UVCH-05L50L40	1265×1200×1209	113
-	UVCH-15L25C30	1015×914×1201	110
	UVCH-15L25L40	1265×1200×1209	113
-	UVCH-15L32C30	1015×914×1201	110
	UVCH-15L32L40	1265×1200×1209	113
-	UVCH-15L40A12	1015×660×1201	92
	UVCH-15L40A20	1015×660×1201	104
-	UVCH-15L40C12	1015×914×1201	93
-	UVCH-15L40C20	1015×914×1201	105
-	UVCH-15L40C30	1015×914×1201	110
-	UVCH-15L40L40	1265×1200×1209	113
-	UVCH-15L50A12	1015×660×1201	98
	UVCH-15L50A20	1015×660×1201	104
-	UVCH-15L50C12	1015×914×1201	99
-	UVCH-15L50C20	1015×914×1201	105
-	UVCH-15L50C30	1015×914×1201	110
-	UVCH-15L50L40	1265×1200×1209	113

Selection table of cradle

UVH type, H type

Arc resistance	Type of cradle	Outline dimension H×W×D [mm]	Dimension page
-	UVCH-05C25C30	1060×914×1201	111
-	UVCH-05C32C30	1060×914×1201	111
-	UVCH-05C40A12	1060×660×1201	94
-	UVCH-05C40A20	1060×660×1201	106
-	UVCH-05C40C12	1060×914×1201	95
-	UVCH-05C40C20	1060×914×1201	107
-	UVCH-05C40C30	1060×914×1201	111
-	UVCH-05C50A12	1060×660×1201	94
-	UVCH-05C50A20	1060×660×1201	106
-	UVCH-05C50C12	1060×914×1201	95
-	UVCH-05C50C20	1060×914×1201	106
-	UVCH-05C50C30	1060×914×1201	111
-	UVCH-15C25C30	1060×914×1201	111
-	UVCH-15C32C30	1060×914×1201	111
-	UVCH-15C40A12	1060×660×1201	94
-	UVCH-15C40A20	1060×660×1201	106
-	UVCH-15C40C12	1060×914×1201	95
-	UVCH-15C40C20	1060×914×1201	106
-	UVCH-15C40C30	1060×914×1201	111
-	UVCH-15C50A12	1060×660×1201	100
-	UVCH-15C50A20	1060×660×1201	106
-	UVCH-15C50C12	1060×914×1201	101
-	UVCH-15C50C20	1060×914×1201	107
-	UVCH-15C50C30	1060×914×1201	111
-	UVCH-05H25C30	1015×914×1067	112
-	UVCH-05H25L40	1265×1200×1209	114
-	UVCH-05H32C30	1015×914×1067	112
-	UVCH-05H32L40	1265×1200×1209	114
-	UVCH-05H40A12	1015×660×1067	96
-	UVCH-05H40A20	1015×660×1067	108
-	UVCH-05H40C12	1015×914×1067	97
-	UVCH-05H40C20	1015×914×1067	109
-	UVCH-05H40C30	1015×914×1067	112
-	UVCH-05H40L40	1265×1200×1209	114
-	UVCH-05H50A12	1015×660×1067	102
-	UVCH-05H50A20	1015×660×1067	108
-	UVCH-05H50C12	1015×914×1067	103
-	UVCH-05H50C20	1015×914×1067	109
-	UVCH-05H50C30	1015×914×1067	112
-	UVCH-05H50L40	1265×1200×1209	114
-	UVCH-15H25C30	1015×914×1067	112
-	UVCH-15H25L40	1265×1200×1209	114
-	UVCH-15H32C30	1015×914×1067	112
-	UVCH-15H32L40	1265×1200×1209	114
-	UVCH-15H40A12	1015×660×1067	96
-	UVCH-15H40A20	1015×660×1067	108
-	UVCH-15H40C12	1015×914×1067	97
-	UVCH-15H40C20	1015×914×1067	109
-	UVCH-15H40C30	1015×914×1067	112
-	UVCH-15H40L40	1265×1200×1209	114
-	UVCH-15H50A12	1015×660×1067	102
-	UVCH-15H50A20	1015×660×1067	108
-	UVCH-15H50C12	1015×914×1067	103
-	UVCH-15H50C20	1015×914×1067	109
-	UVCH-15H50C30	1015×914×1067	112
-	UVCH-15H50L40	1265×1200×1209	114

Selection guide of circuit breaker type

Selection table of cradle

UVH type, H type

Arc resistance	Type of cradle	Outline dimension H×W×D [mm]	Dimension page
-	UVCH-27L25C25	1121×914×1441	117
-	UVCH-27L25C28	1121×914×1441	118
-	UVCH-27L32C12	1121×914×1441	115
-	UVCH-27L32C20	1121×914×1441	116
-	UVCH-27L32C25	1121×914×1441	117
-	UVCH-27L32C28	1121×914×1441	118
-	UVCH-27L40C12	1121×914×1441	115
-	UVCH-27L40C20	1121×914×1441	116
-	UVCH-27L40C25	1121×914×1441	117
-	UVCH-27L40C28	1121×914×1441	118
-	UVCH-27H25C25	1177×914×1695	125
-	UVCH-27H25C28	1177×914×1695	126
-	UVCH-27H32C12	1177×914×1695	123
-	UVCH-27H32C20	1177×914×1695	124
-	UVCH-27H32C25	1177×914×1695	125
-	UVCH-27H32C28	1177×914×1695	126
-	UVCH-27H40C12	1177×914×1695	123
-	UVCH-27H40C20	1177×914×1695	124
-	UVCH-27H40C25	1177×914×1695	125
-	UVCH-27H40C28	1177×914×1695	126
-	UVCH-27C25C25	1177×914×1441	121
-	UVCH-27C25C28	1177×914×1441	122
-	UVCH-27C32C12	1177×914×1441	119
-	UVCH-27C32C20	1177×914×1441	120
-	UVCH-27C32C25	1177×914×1441	121
-	UVCH-27C32C28	1177×914×1441	122
-	UVCH-27C40C12	1177×914×1441	119
-	UVCH-27C40C20	1177×914×1441	120
-	UVCH-27C40C25	1177×914×1441	121
-	UVCH-27C40C28	1177×914×1441	122
-	UVCH-38H32E12	1827×1066×1851	127
-	UVCH-38H32E20	1827×1066×1851	127
-	UVCH-38H40E12	1827×1066×1851	127
-	UVCH-38H40E20	1827×1066×1851	127

Full description for circuit breaker

UVH type, Drawout type

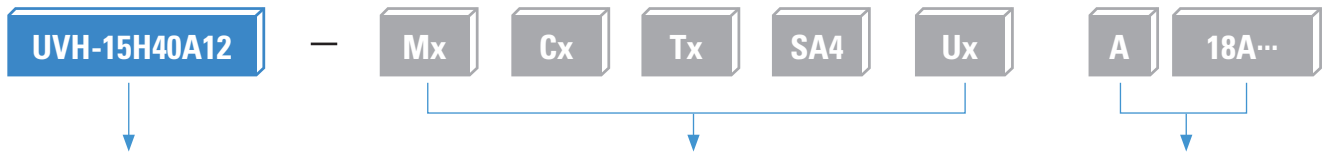

1 Type of circuit breaker
(select from the previous page)

2 Control source and auxiliary contacts & connector

3 Accessories

※ In case of selecting 3 Accessories, only type Symbol 'A' once. (ex. A18A)

Order form for circuit breaker

Please select only one of the items on the same horizontal line. (* Required selection)

UVH, VCB, Drawout type

no extra charge extra charge

1 Type of VCB from selection table*

ea

2 Control source

Motor* (Mx)								page 154
<input type="radio"/> M0	<input type="radio"/> M1	<input type="radio"/> M2	<input type="radio"/> M3	<input type="radio"/> M5	<input type="radio"/> M6	<input type="radio"/> M7	<input type="radio"/> M8	
Without motor	DC 110V	DC 200V ~ 250V	DC 125V	DC 48V ~ 60V	AC 48V	AC 100V ~ 130V	AC 200V ~ 250V	
Closing coil* (Cx)								page 155
<input type="radio"/> C0	<input type="radio"/> C1	<input type="radio"/> C2	<input type="radio"/> C3	<input type="radio"/> C5	<input type="radio"/> C6	<input type="radio"/> C7	<input type="radio"/> C8	
Without CC	DC 110V	DC 200V ~ 250V	DC 125V	DC 48V ~ 60V	AC 48V	AC 100V ~ 130V	AC 200V ~ 250V	
Shunt trip coil* (Tx)								page 156
<input type="radio"/> T0	<input type="radio"/> T1	<input type="radio"/> T2	<input type="radio"/> T3	<input type="radio"/> T5	<input type="radio"/> T6	<input type="radio"/> T7	<input type="radio"/> T8	
Without SHT	DC 110V	DC 200V ~ 250V	DC 125V	DC 48V ~ 60V	AC 48V	AC 100V ~ 130V	AC 200V ~ 250V	
Auxiliary contacts & Connector type*								page 159
<input type="radio"/> SC2 (4a4b Standard type, Auto-con type)				<input type="radio"/> SC4 (10a10b Standard type, Auto-con type)				
Under voltage release (Ux)								page 160
<input type="radio"/> U0	<input type="checkbox"/> U1	<input type="checkbox"/> U2	<input type="checkbox"/> U3	<input type="checkbox"/> U5	<input type="checkbox"/> U6	<input type="checkbox"/> U7	<input type="checkbox"/> U8	
Without UVT	DC 110V	DC 200V ~ 250V	DC 125V	DC 48V ~ 60V	AC 48V	AC 100V ~ 130V	AC 200V ~ 250V	
※ Even without UVT, U0 must be selected to make VCB ordering code and description								

3 Accessories

Combination table

U0	1	
U1~8		1
A1 & A2	1	
A6		1

Available no. of Aux. contact

Symbol	10a10b
Standard	10 NO, 10 NC
with A1	10 NO, 10 NC
with A2	10 NO, 9 NC

Secondary shunt trip coil		page 157
<input type="checkbox"/> A1 (Secondary shunt trip coil)	<input type="checkbox"/> A2 (Secondary shunt trip coil monitoring contact)	
※ In case of selecting A2, maximum auxiliary contacts are 10a9b		
Latch checking s/w		page 161
<input type="checkbox"/> A6		
※ In case of selecting UVT(U1~U8), Latch checking S/W should be selected.		
Keylock		page 162
<input type="checkbox"/> A7 (Keylock(Individual key))	<input type="checkbox"/> AG (Keylock(Same key))	<input type="checkbox"/> AM (KirkKey, CAMLOCK type)
Button padlock		page 163
<input type="checkbox"/> A8 (Button padlock)		
MOC operator*		page 166
<input type="checkbox"/> AE		
Auxiliary wheels (Direct Roll-in, UVH-05/15/27H ONLY)		page 167
<input type="checkbox"/> AS		

Separately sold accessories

CTU (Coil test unit)	<input type="checkbox"/> 73873171221 CTU (Coil test unit)	page 169
CTD (Condenser trip device)	<input type="checkbox"/> 76113143001 CTD (Condenser trip device) AC/DC 100V, 110V <input type="checkbox"/> 76113143002 CTD (Condenser trip device) AC/DC 200V, 220V	page 170
UDC (UVT delay controller)	<input type="checkbox"/> 52773171282 UDC (UVT delay controller) AC/DC 100~130V <input type="checkbox"/> 52773171283 UDC (UVT delay controller) AC/DC 200~250V <input type="checkbox"/> 52773171281 UDC (UVT delay controller) DC 48~60V and AC 48V	page 171

Order form

Full description for cradle

UVH type, Drawout type

UVCH-05L25A12

A **13567A**

① Type of cradle
(select from the previous page)

③ Accessories

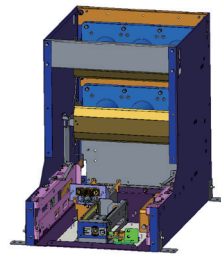

L type

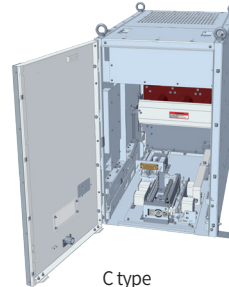

C type



H type

Order form for cradle

Please select only one of the items on the same horizontal line. (* Required selection)

UVH, VCB, Drawout type

(No extra charge extra charge)

① Type of VCB from selection table*	Quantity	ea
② Control source		
Lead wire*		page 164
<input type="checkbox"/> A1 (4a4b)	<input type="checkbox"/> A2 (10a10b)	
Standard set (Shutter padlock, TOC, MOC)*		page 172 ~ 173
<input type="checkbox"/> A3 (6a6b(MOC,TOC)) (UVCH-05/15H ONLY)	<input type="checkbox"/> A4 (12a12b(MOC,TOC)) (UVCH-05/15H ONLY)	
<input type="checkbox"/> A3 (4a4b(MOC,TOC)) (UVCH-38H ONLY)		
※ In case of selecting Remote Racking System, Maximum contacts of MOC are 4a4b. ※ In case of selecting Remote Racking System, Maximum contacts of MOC are 10a10b.		
Padlock (UVCH-05/15H ONLY)		page 173
<input type="checkbox"/> A5		
Door (Only for H type cradle)		page 174
<input type="checkbox"/> A6		
Door interlock (Only for H type cradle)		page 175
<input type="checkbox"/> A7		
Door emergency push button (UVCH-38H ONLY)		page 163
<input type="checkbox"/> A8 (Button padlock)		
Kirk key interlock (UVCH-05/15H ONLY)		page 174
<input type="checkbox"/> A9		
※ In case of selecting Remote Racking System, A9 must be selected to make cradle ordering code and description. The Kirk-key is not provided separately.		
Remote racking system (Only for H type cradle) (UVCH-05/15H ONLY)		page 177
<input type="checkbox"/> AA (AC120V, Without OPEN, CLOSE Function)	<input type="checkbox"/> AB (AC240V, Without OPEN, CLOSE Function)	
<input type="checkbox"/> AC (DC125V, Without OPEN, CLOSE Function)	<input type="checkbox"/> AD (DC250V, Without OPEN, CLOSE Function)	
<input type="checkbox"/> AE (AC120V, With OPEN, CLOSE Function)	<input type="checkbox"/> AF (AC240V, With OPEN, CLOSE Function)	
<input type="checkbox"/> AG (DC125V, With OPEN, CLOSE Function)	<input type="checkbox"/> AH (DC250V, With OPEN, CLOSE Function)	

Separately sold accessories

Racking In/Out handle	page 179 ~ 180
<input type="checkbox"/> 55223172411 (UVCH L-Cradle)	
<input type="checkbox"/> 55213163003 (UVCH-38H-Cradle)	
<input type="checkbox"/> 55223181001 (Universal / UVCH-05/15/27H-Cradle up to 3000A)	
<input type="checkbox"/> 55223181002 (Universal / UVCH-05/15/27H-Cradle up to 3000A Remote Racking System)	
<input type="checkbox"/> 55223181003 (Universal / UVCH-05/15H-Cradle 4000A)	
<input type="checkbox"/> 55223181004 (Universal Universal / UVCH-05/15H-Cradle 4000A Remote Racking System)	
Charge handle	page 179
<input type="checkbox"/> 55213143046	
Extension rail	page 181 ~ 182
<input type="checkbox"/> 59023181003 (L-Cradle / C-Cradle / H-Cradle for UVCH-05/15H)	
<input type="checkbox"/> 59023181009 (H-Cradle for UVCH-27H)	

4.76/15kV, 40kA, 1200A

UVH type, Drawout type

Type of circuit breaker

UVH-05H40A12
UVH-15H40A12

[Unit: inch(mm)]

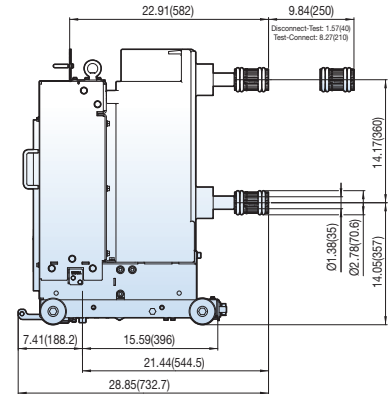
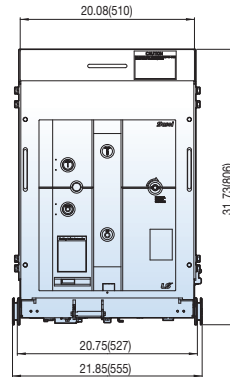
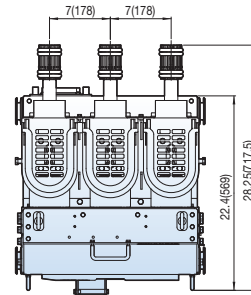

Type of circuit breaker

UVH-05H40C12
UVH-15H40C12

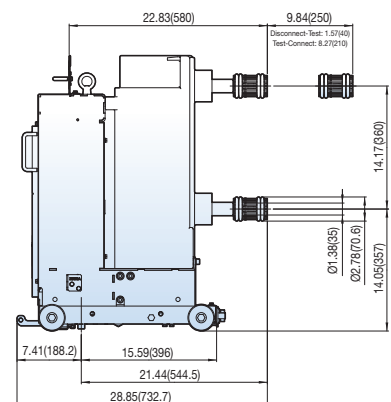
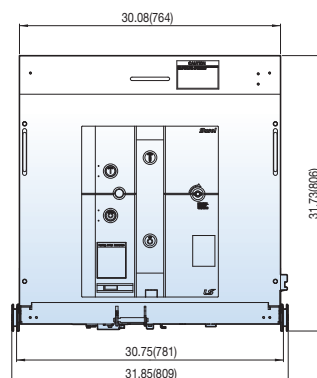
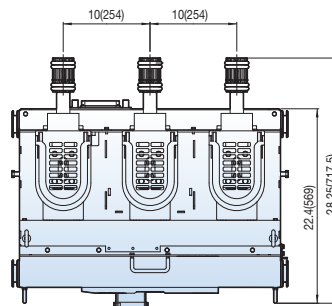

Dimensions

4.76/15kV, 50kA, 1200A

UVH type, Drawout type

Type of circuit breaker

- UVH-05H50A12
- UVH-15H50A12

[Unit: inch(mm)]

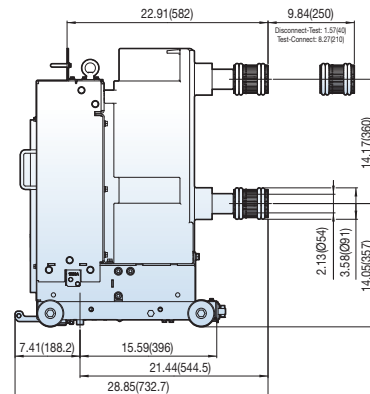
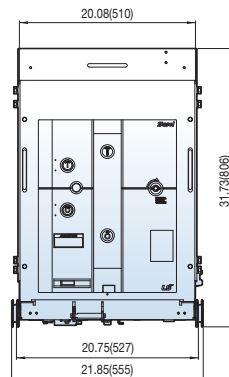
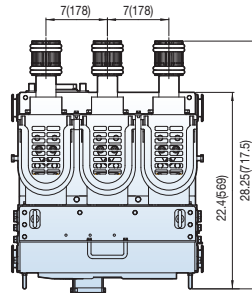

Type of circuit breaker

- UVH-05H50C12
- UVH-15H50C12

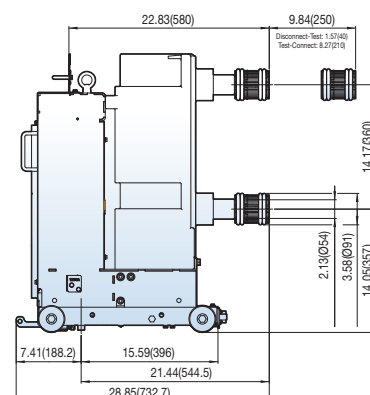
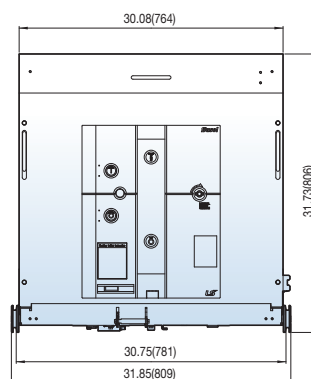
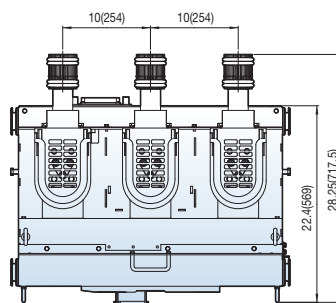

4.76/15kV, 40/50kA, 2000A

UVH type, Drawout type

Type of circuit breaker

- UVH-05H40A20
- UVH-05H50A20
- UVH-15H40A20
- UVH-15H50A20

[Unit: inch(mm)]

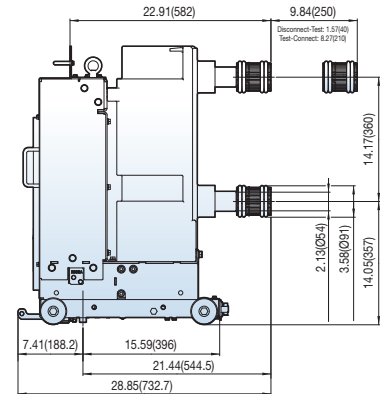
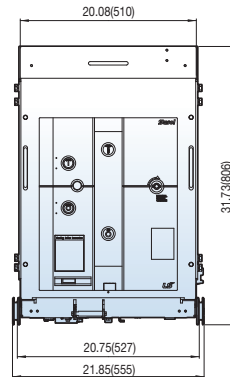
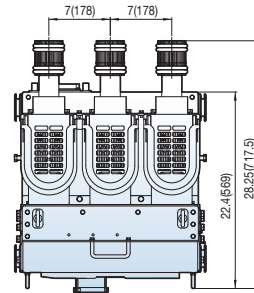

Type of circuit breaker

- UVH-05H40C20
- UVH-05H50C20
- UVH-15H40C20
- UVH-15H50C20

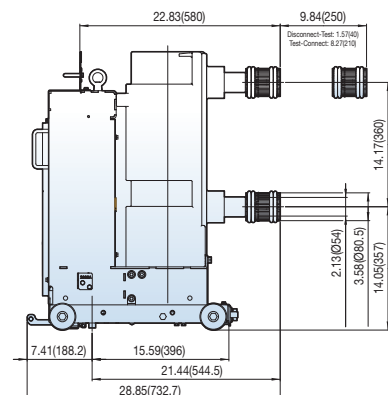
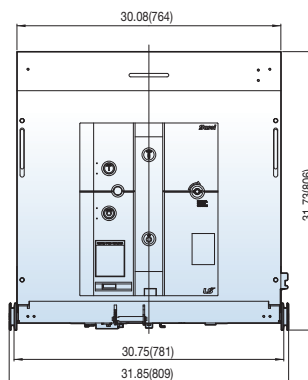
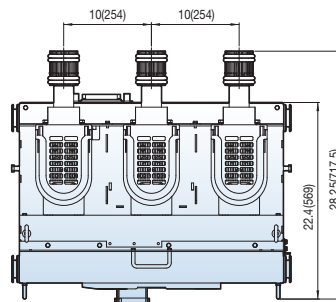

Dimensions

4.76/15kV, 25/31.5/40/50kA, 3000A

UVH type, Drawout type

Type of circuit breaker

- UVH-05H25C30
- UVH-05H32C30
- UVH-05H40C30
- UVH-05H50C30
- UVH-15H25C30
- UVH-15H32C30
- UVH-15H40C30
- UVH-15H50C30

[Unit: inch(mm)]

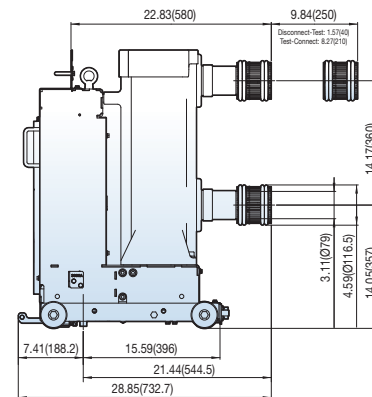
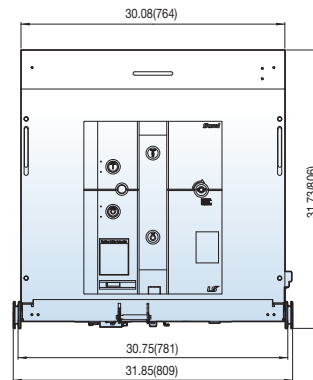
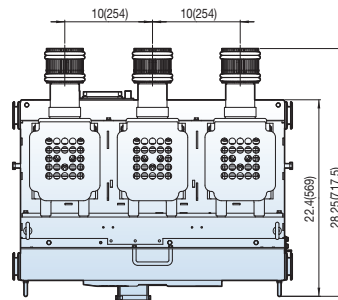

4.76/15kV, 25/31.5/40/50kA, 4000A

Type of circuit breaker

- UVH-05H25L40
- UVH-05H32L40
- UVH-05H40L40
- UVH-05H50L40
- UVH-15H25L40
- UVH-15H32L40
- UVH-15H40L40
- UVH-15H50L40

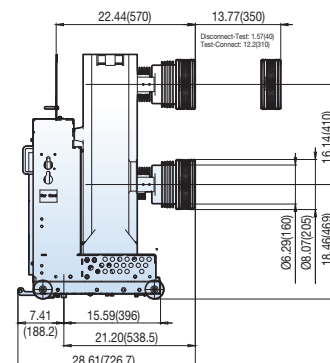
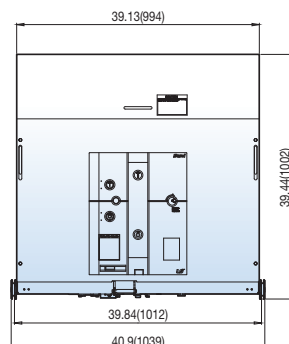
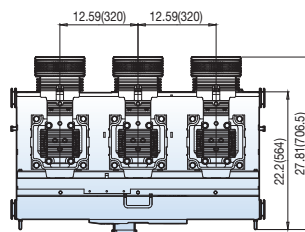

27kV, 31.5/40kA, 1200A

UVH type, Drawout type

Type of circuit breaker

- UVH-27H32C12
- UVH-27H40C12

[Unit: inch(mm)]

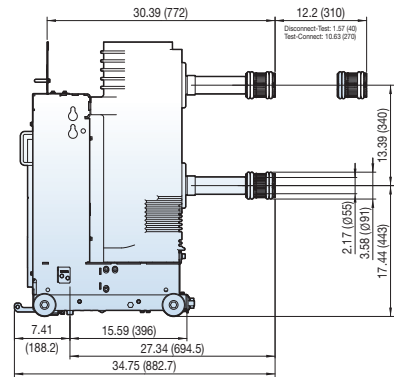
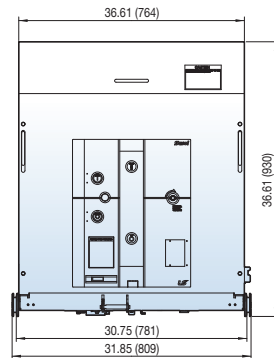
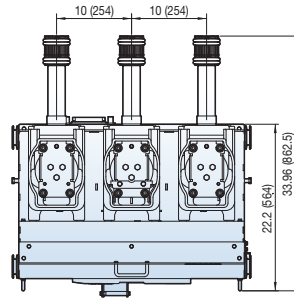

27kV, 31.5/40kA, 2000A

Type of circuit breaker

- UVH-27H32C20
- UVH-27H40C20

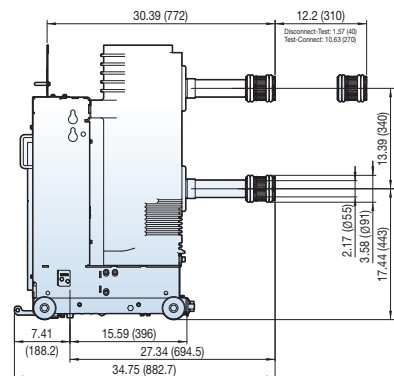
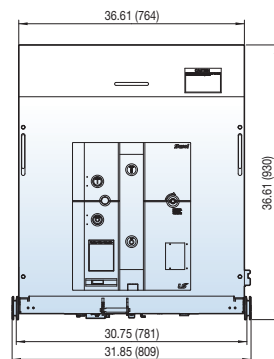
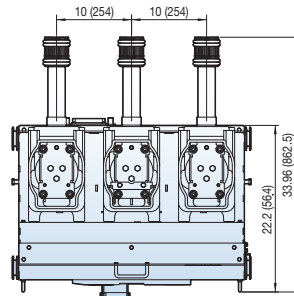

Dimensions

27kV, 25/31.5/40kA, 2500A

UVH type, Drawout type

Type of circuit breaker

- UVH-27H25C25
- UVH-27H32C25
- UVH-27H40C25

[Unit: inch(mm)]

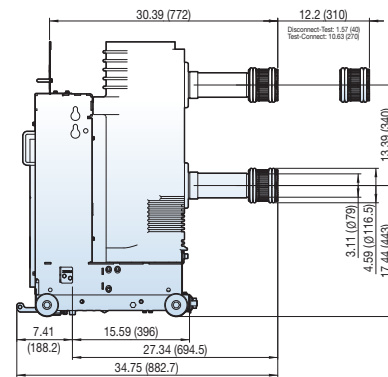
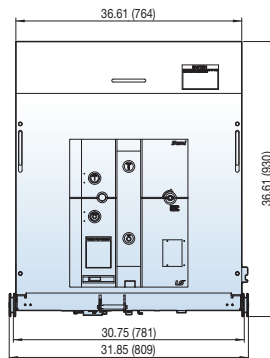
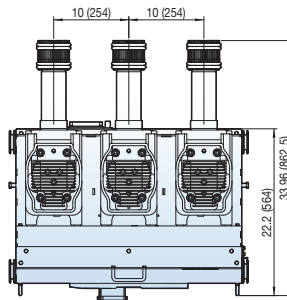

27kV, 25/31.5/40kA, 2750A

Type of circuit breaker

- UVH-27H25C28
- UVH-27H32C28
- UVH-27H40C28

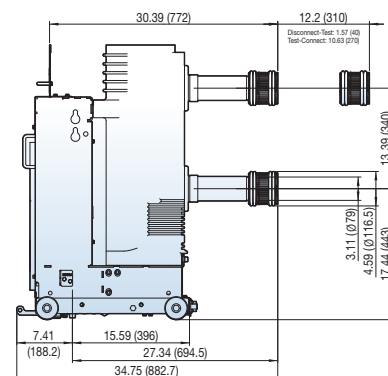
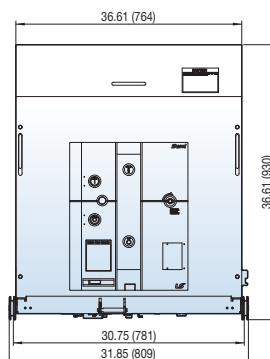
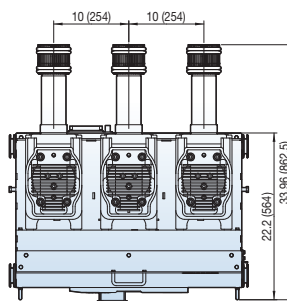

38kV, 31.5/40kA, 1200/2000A

UVH type, Drawout type

Type of circuit breaker

- UVH-38H32E12
- UVH-38H32E20
- UVH-38H40E12
- UVH-38H40E20

[Unit: inch(mm)]

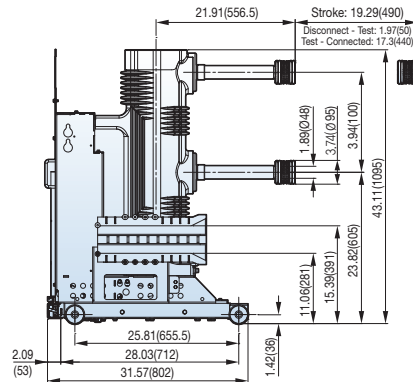
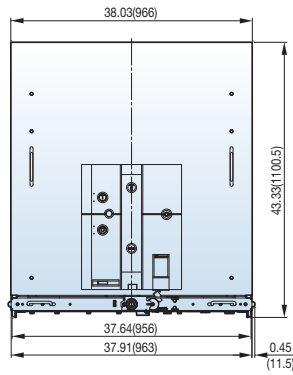
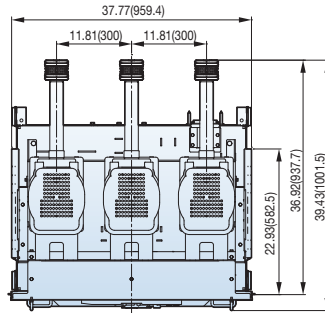

Dimensions

4.76/15kV, 40kA, 1200A

UVH type, Drawout type

Type of cradle

UVCH-05L40A12
UVCH-15L40A12

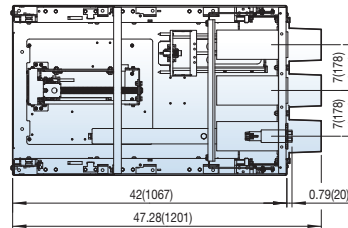
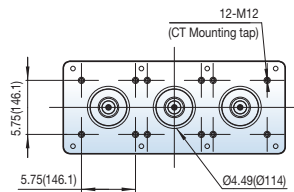

[Unit: inch(mm)]

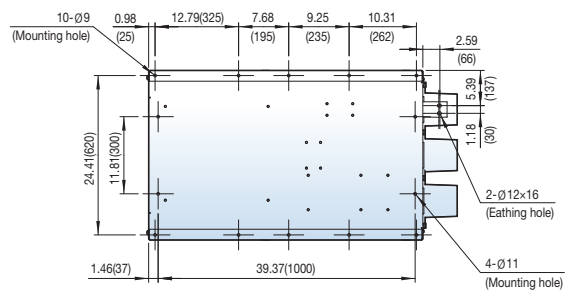
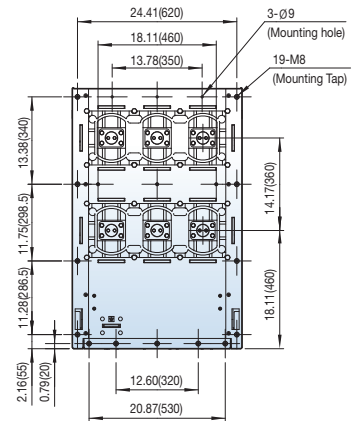
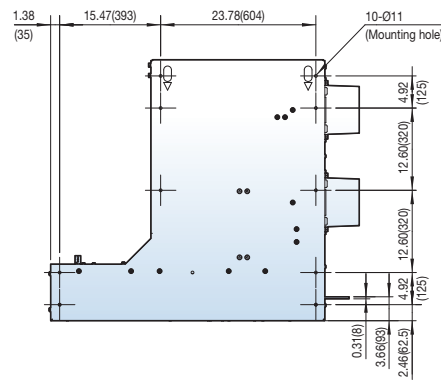
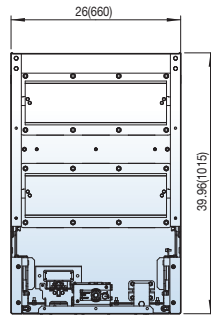
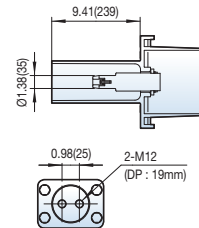

4.76/15kV, 40kA, 1200A

UVH type, Drawout type

Type of cradle

UVCH-05L40C12
UVCH-15L40C12

[Unit: inch(mm)]

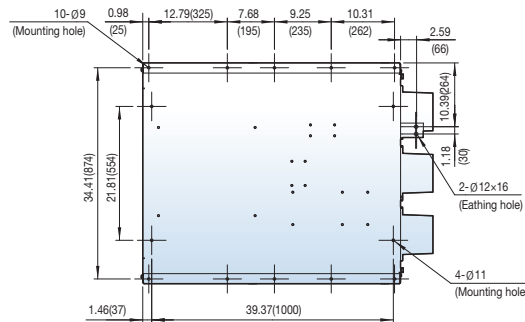
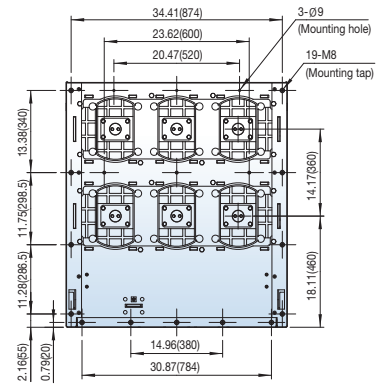
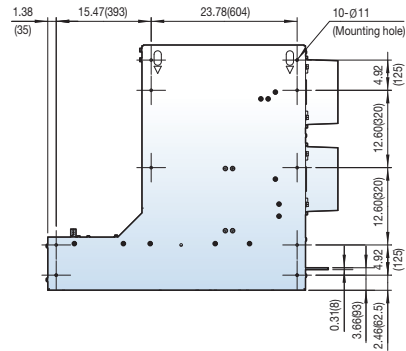
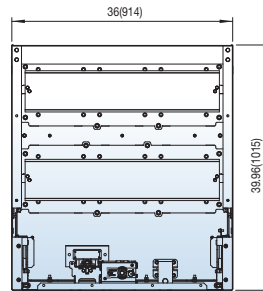
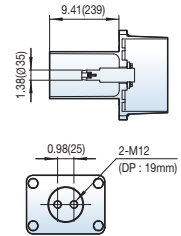
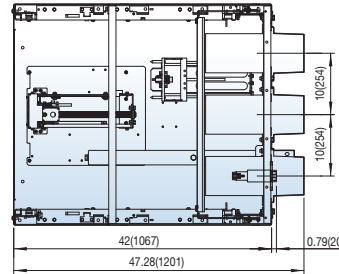
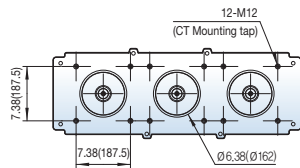

Dimensions

4.76/15kV, 40kA, 1200A

UVH type, Drawout type

Type of cradle

UVCH-05C40A12
UVCH-15C40A12

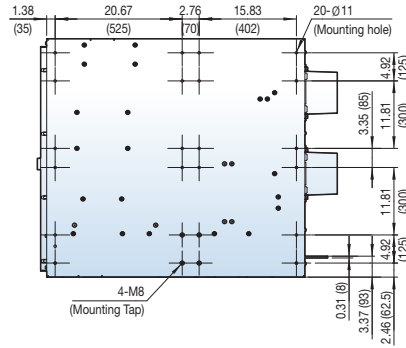
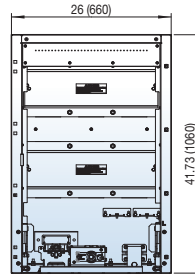
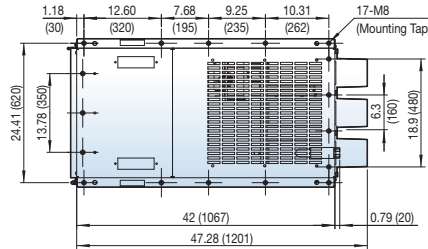
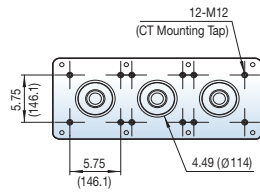

[Unit: inch(mm)]

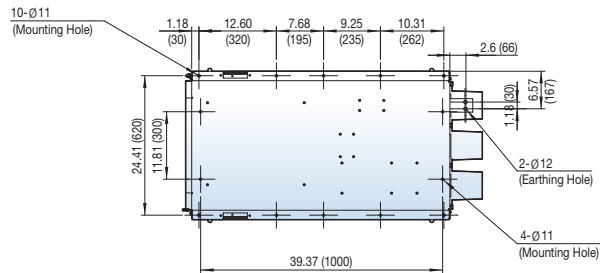
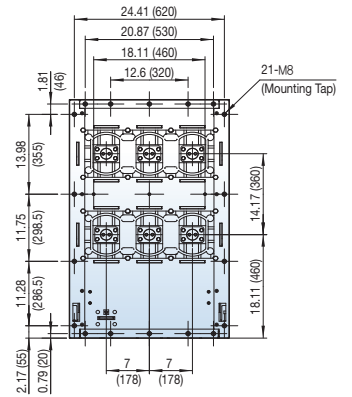
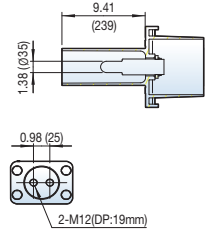

4.76/15kV, 40kA, 1200A

UVH type, Drawout type

Type of cradle

- UVCH-05C40C12
- UVCH-15C40C12

[Unit: inch(mm)]

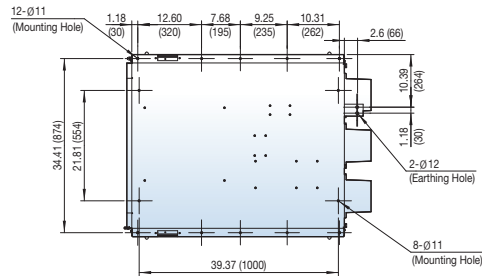
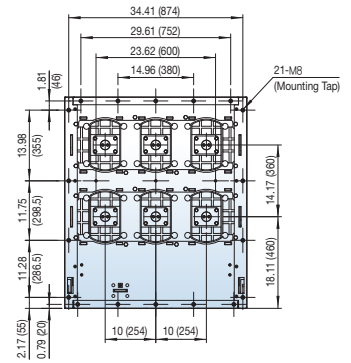
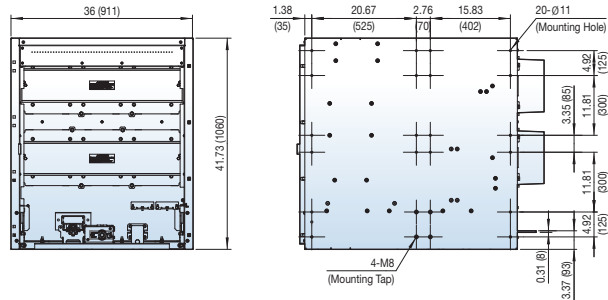
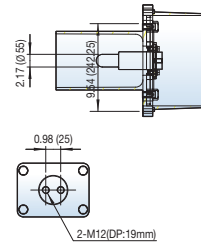
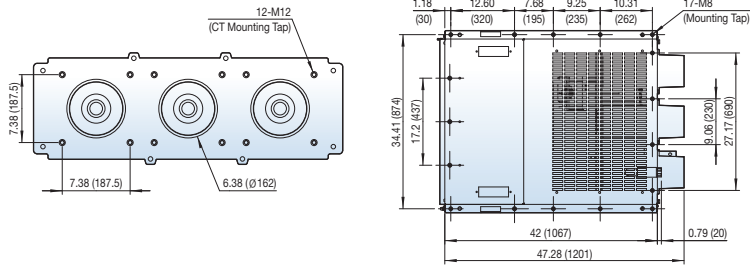

Dimensions

4.76/15kV, 40kA, 1200A

UVH type, Drawout type

Type of cradle

UVCH-05H40A12
UVCH-15H40A12

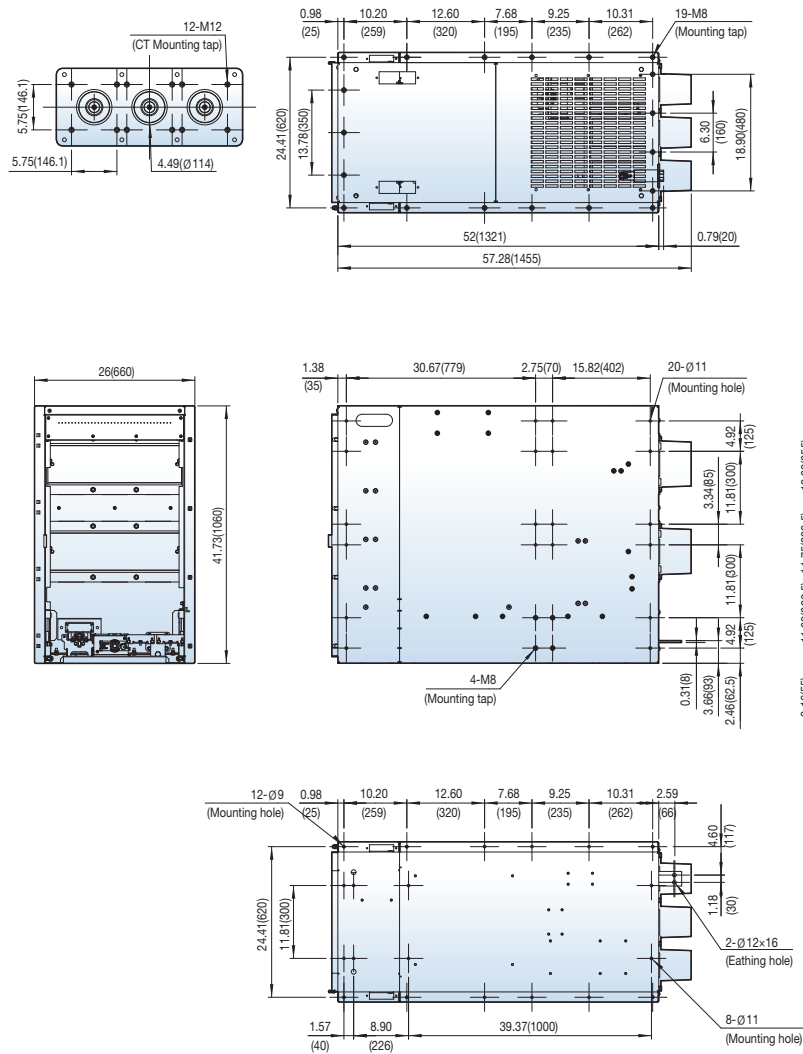

[Unit: inch(mm)]

4.76/15kV, 40kA, 1200A

UVH type, Drawout type

Type of cradle

- UVCH-05H40C12
- UVCH-15H40C12

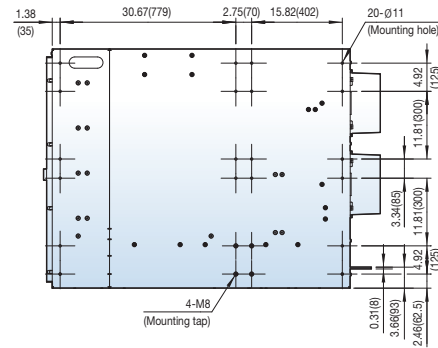
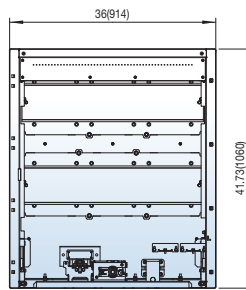
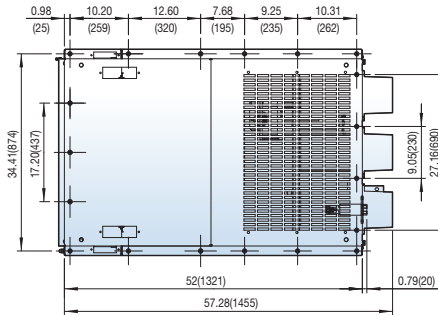
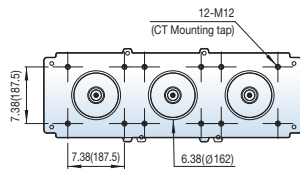

[Unit: inch(mm)]

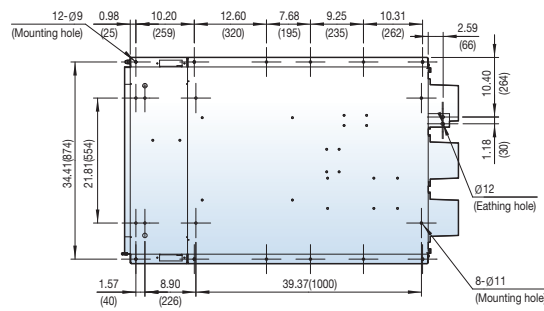
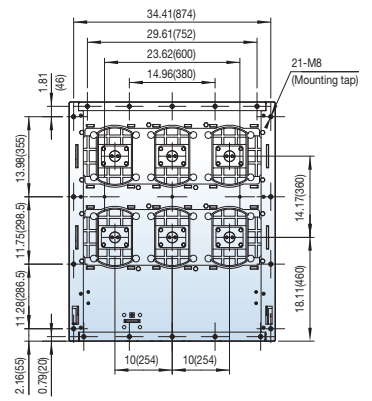
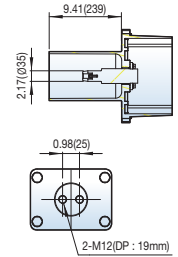

Dimensions

4.76/15kV, 50kA, 1200A

UVH type, Drawout type

Type of cradle

UVCH-05L50A12
UVCH-15L50A12

[Unit: inch(mm)]

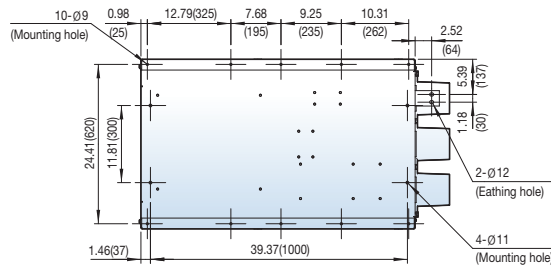
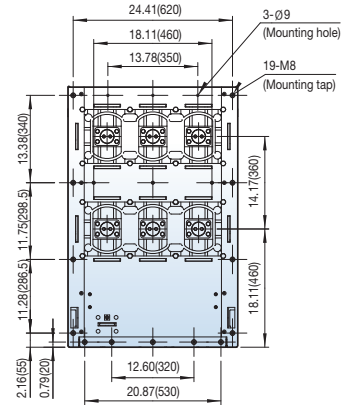
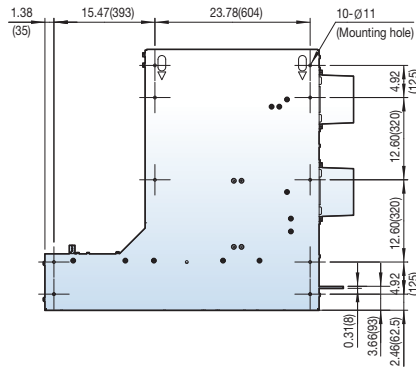
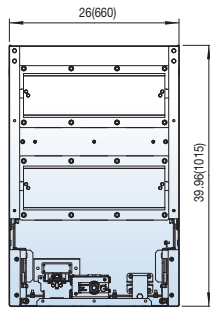
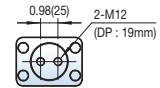
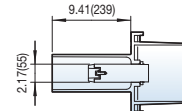
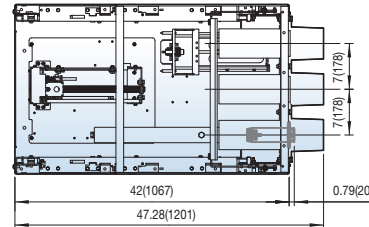
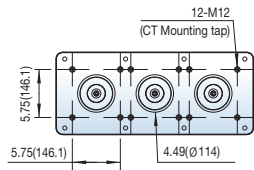

4.76/15kV, 50kA, 1200A

UVH type, Drawout type

Type of cradle

- UVCH-05L50C12
- UVCH-15L50C12

[Unit: inch(mm)]

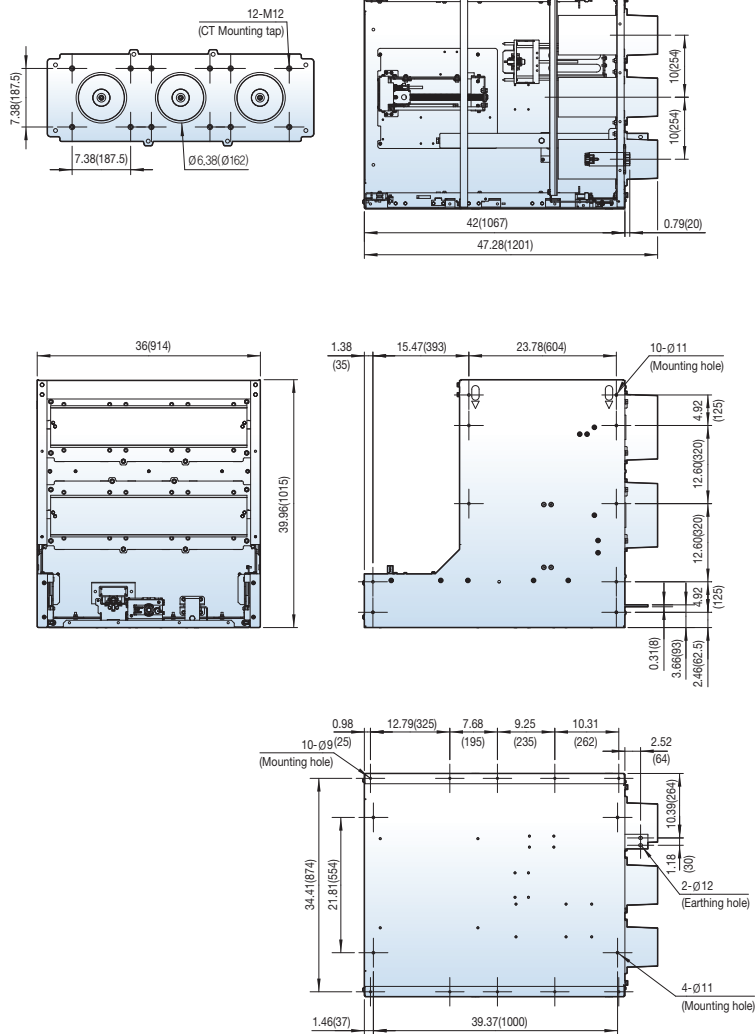

Dimensions

4.76/15kV, 50kA, 1200A

UVH type, Drawout type

Type of cradle

UVCH-05C50A12
UVCH-15C50A12

[Unit: inch(mm)]

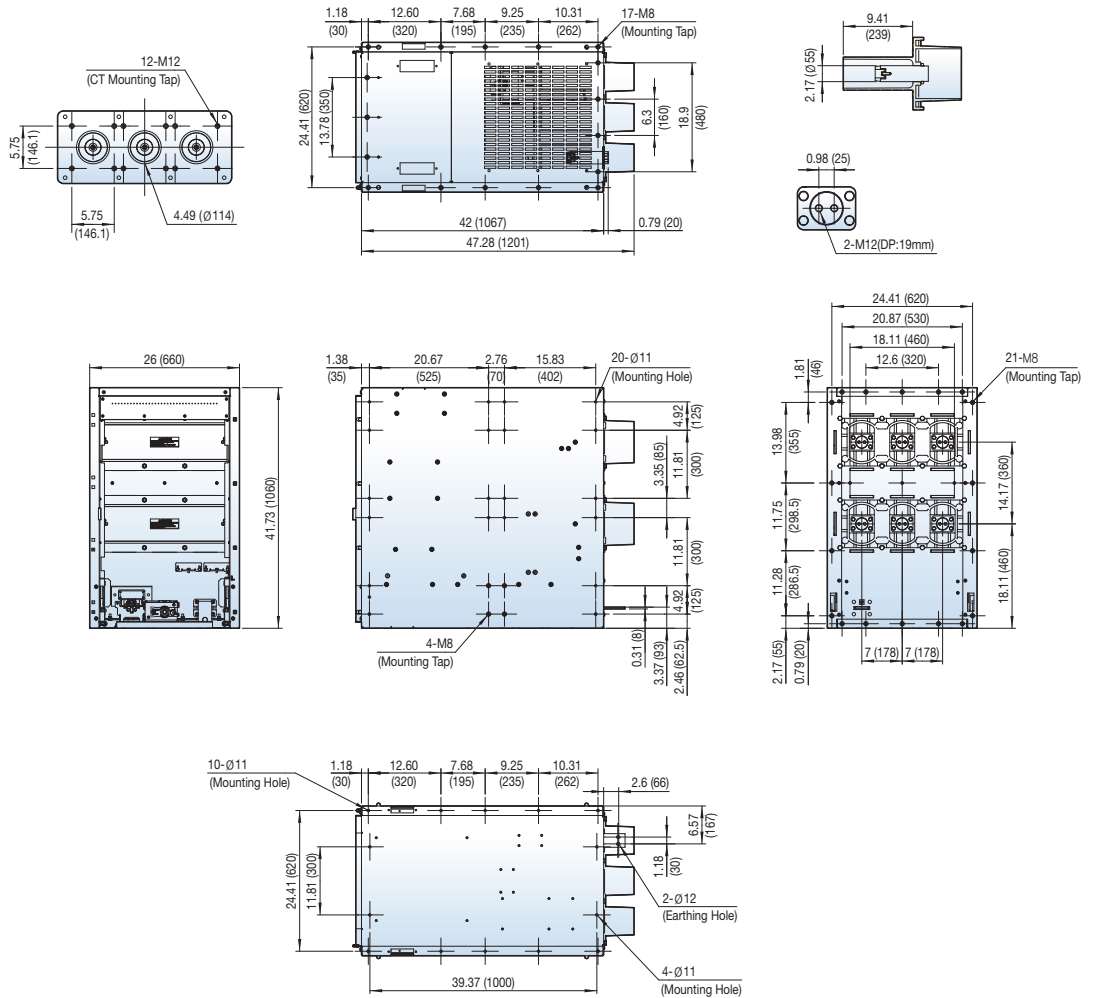

4.76/15kV, 50kA, 1200A

UVH type, Drawout type

Type of cradle

UVCH-05C50C12
UVCH-15C50C12

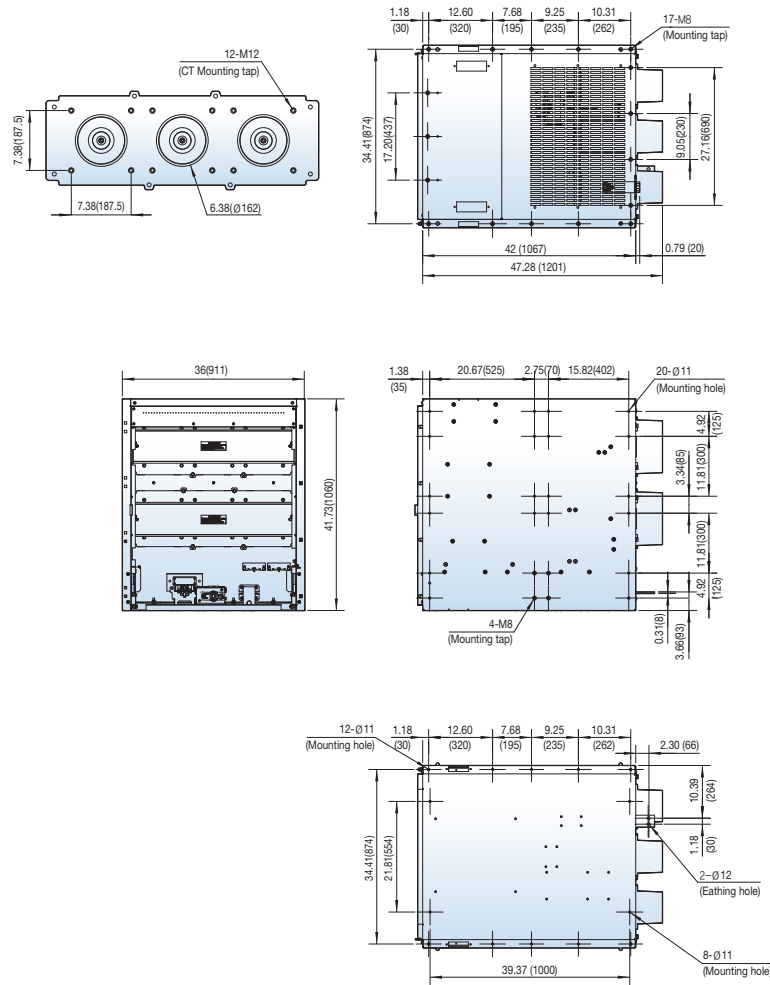

[Unit: inch(mm)]

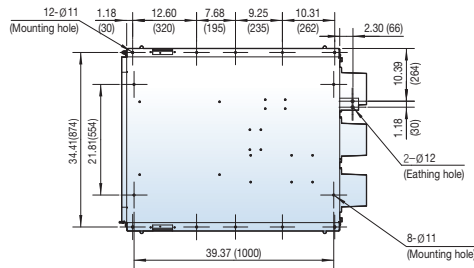
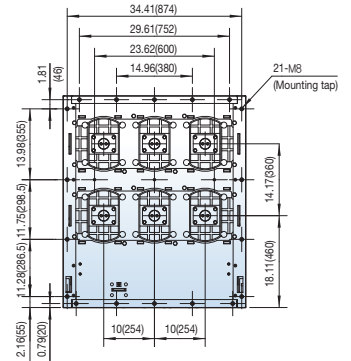
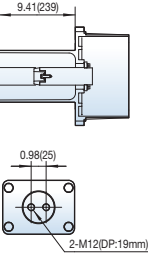

Dimensions

4.76/15kV, 50kA, 1200A

UVH type, Drawout type

Type of cradle

UVCH-05H50A12
UVCH-15H50A12

[Unit: inch(mm)]

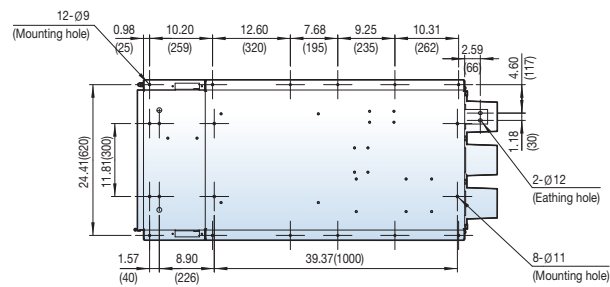
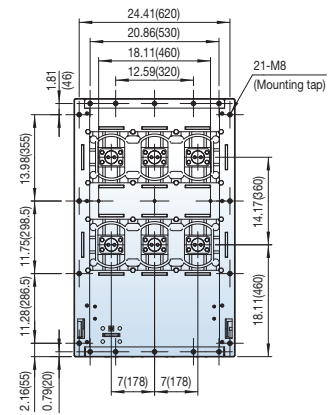
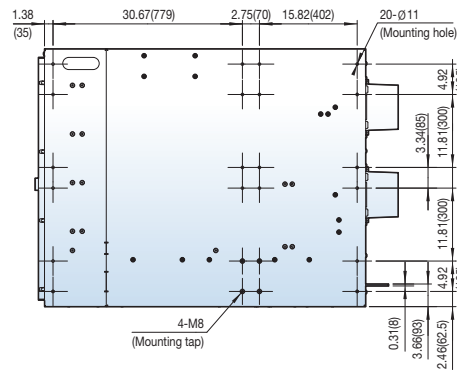
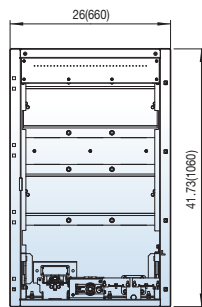
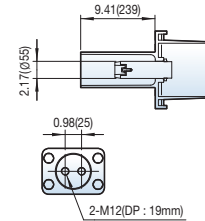
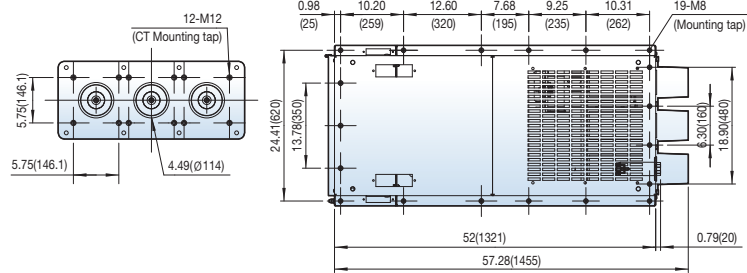

4.76/15kV, 50kA, 1200A

UVH type, Drawout type

Type of cradle

- UVCH-05H50C12
- UVCH-15H50C12

[Unit: inch(mm)]

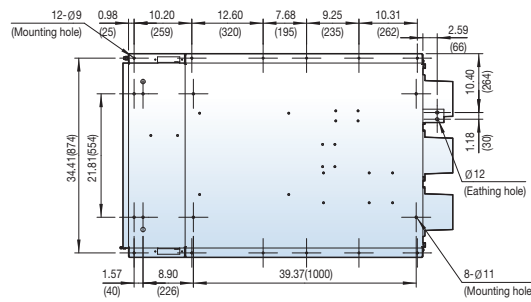
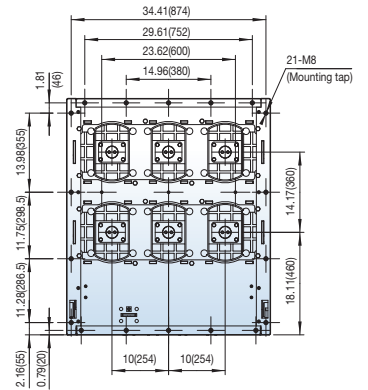
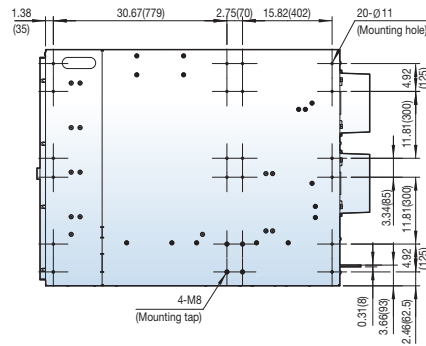
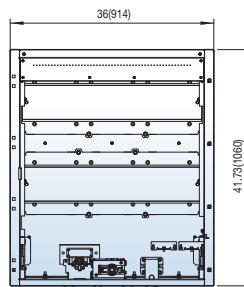
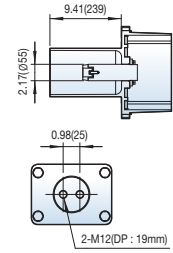
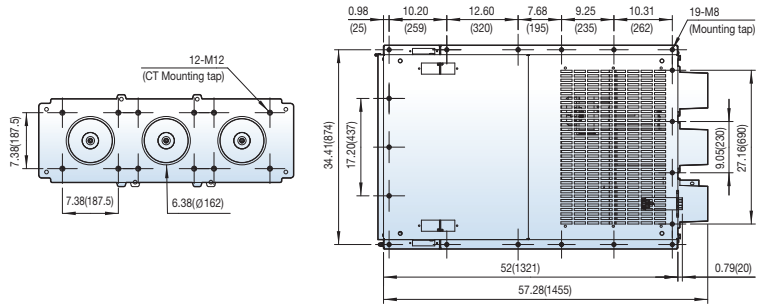

Dimensions

4.76/15kV, 40/50kA, 2000A

UVH type, Drawout type

Type of cradle

- UVCH-05L40A20
- UVCH-05L50A20
- UVCH-15L40A20
- UVCH-15L50A20

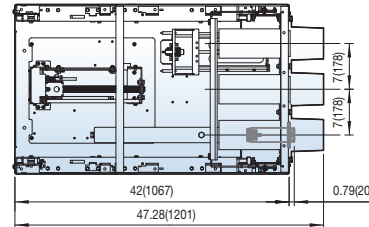
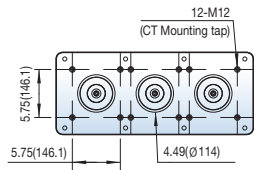

[Unit: inch(mm)]

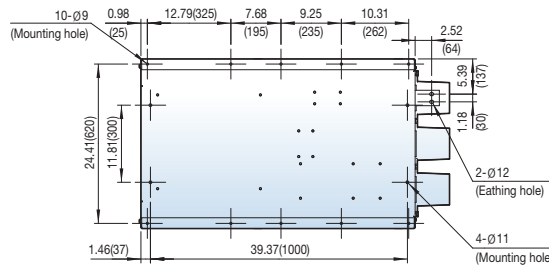
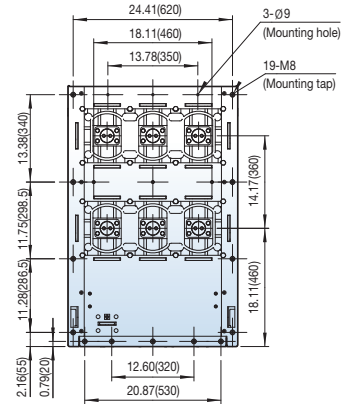
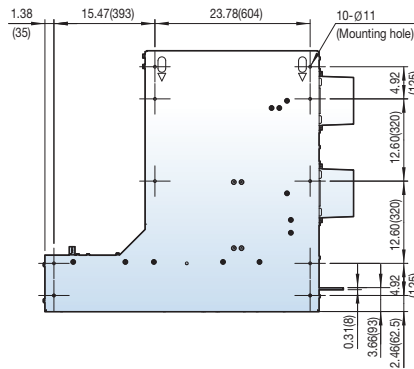
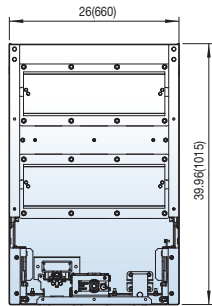
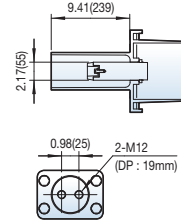

4.76/15kV, 40/50kA, 2000A

UVH type, Drawout type

Type of cradle

- UVCH-05L40C20
- UVCH-05L50C20
- UVCH-15L40C20
- UVCH-15L50C20

[Unit: inch(mm)]

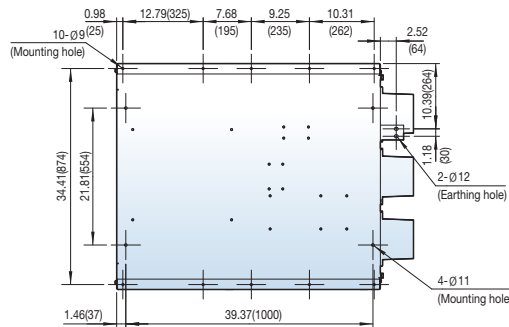
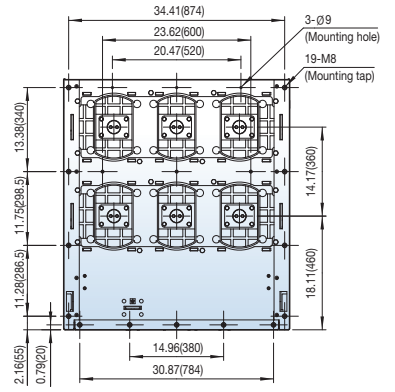
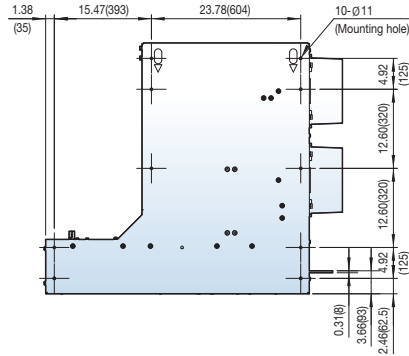
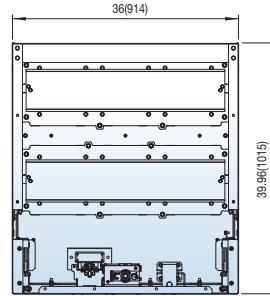
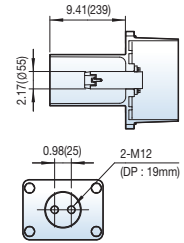
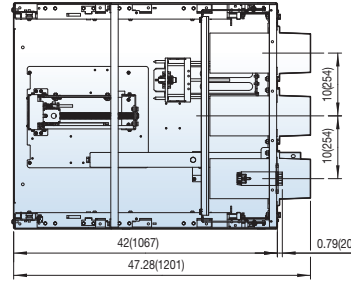
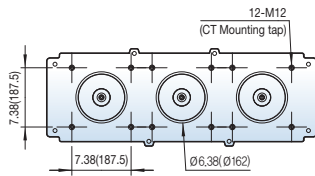

Dimensions

4.76/15kV, 40/50kA, 2000A

UVH type, Drawout type

Type of cradle

- UVCH-05C40A20
- UVCH-05C50A20
- UVCH-15C40A20
- UVCH-15C50A20

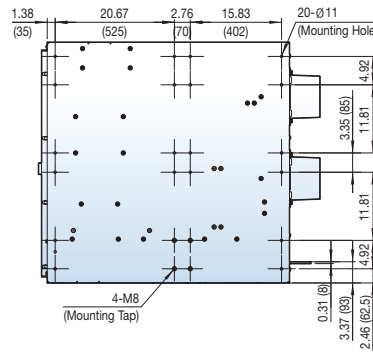
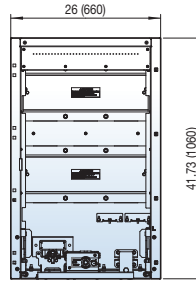
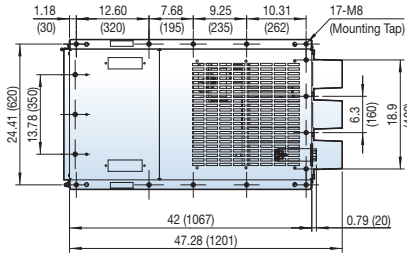
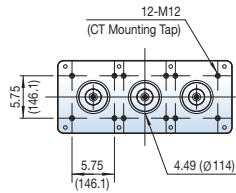

[Unit: inch(mm)]

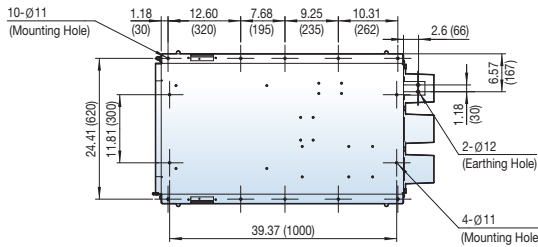
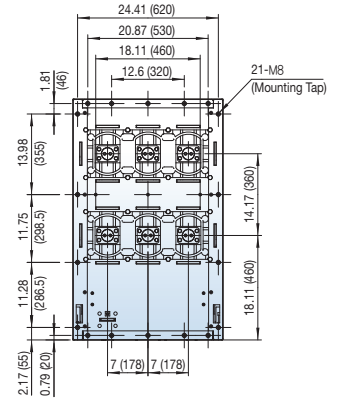
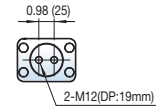
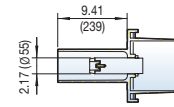

4.76/15kV, 40/50kA, 2000A

UVH type, Drawout type

Type of cradle

- UVCH-05C40C20
- UVCH-05C50C20
- UVCH-15C40C20
- UVCH-15C50C20

[Unit: inch(mm)]

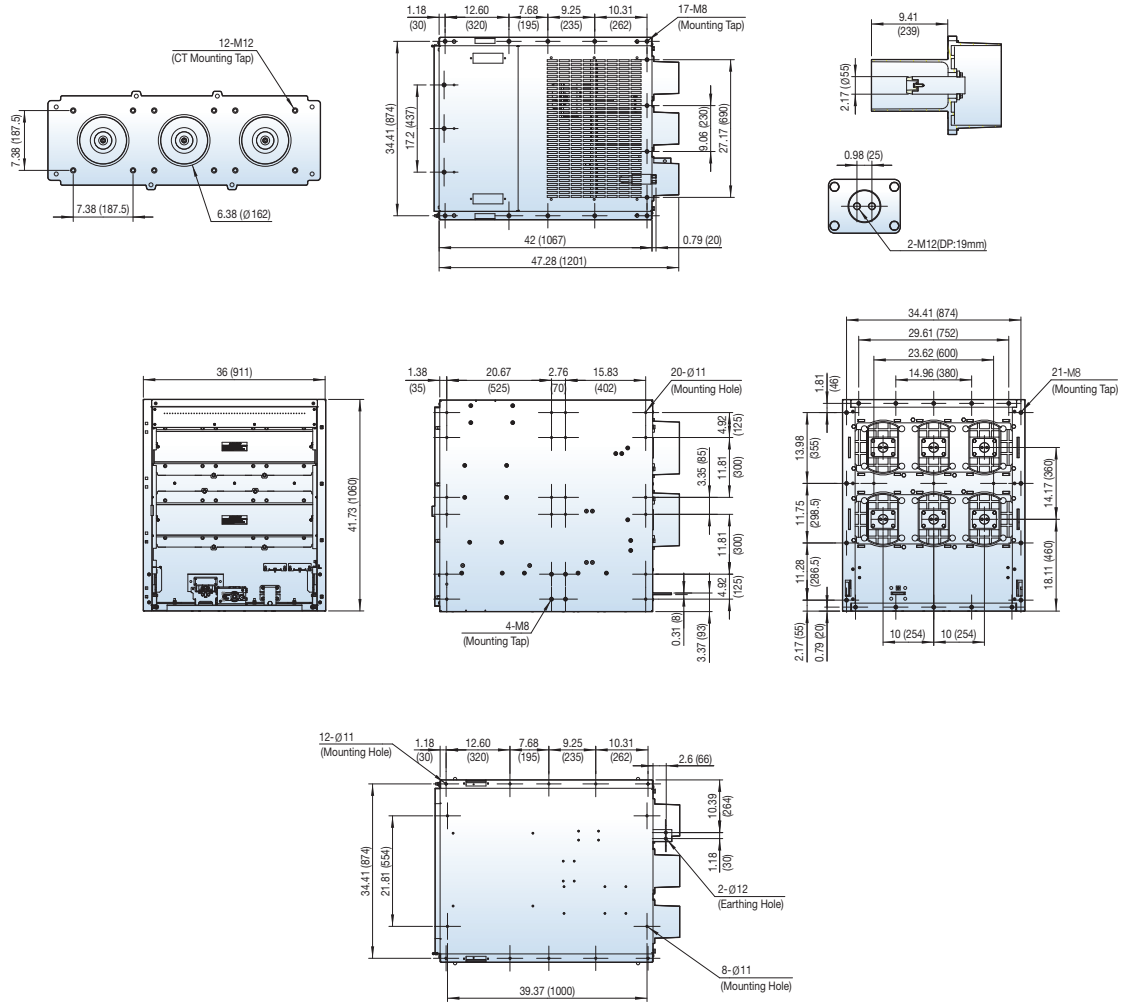

Dimensions

4.76/15kV, 40/50kA, 2000A

Type of cradle

- UVCH-05H40A20
- UVCH-05H50A20
- UVCH-15H40A20
- UVCH-15H50A20

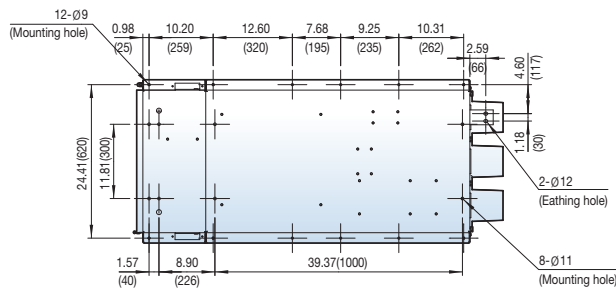
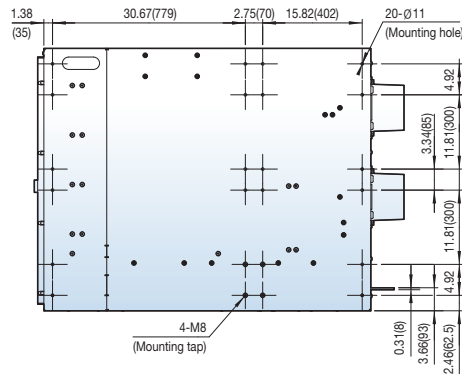
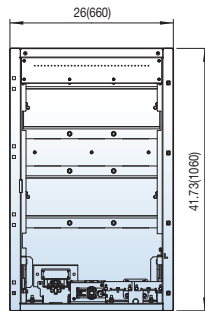
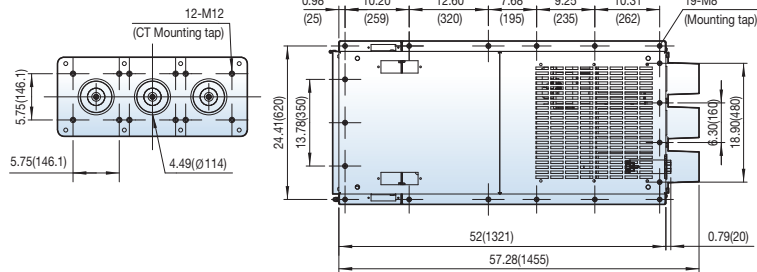

UVH type, Drawout type

[Unit: inch(mm)]

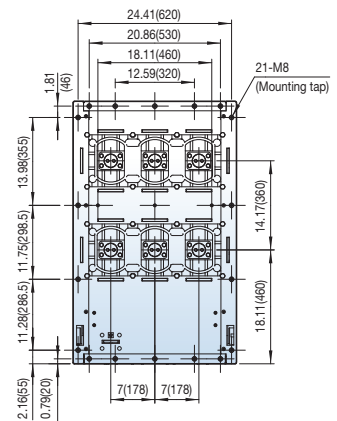
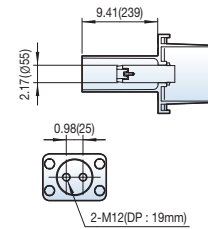

4.76/15kV, 40/50kA, 2000A

UVH type, Drawout type

Type of cradle

- UVCH-05H40C20
- UVCH-05H50C20
- UVCH-15H40C20
- UVCH-15H50C20

[Unit: inch(mm)]

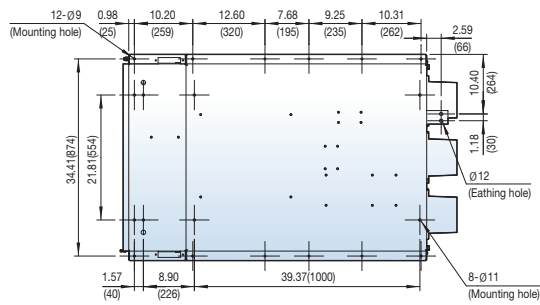
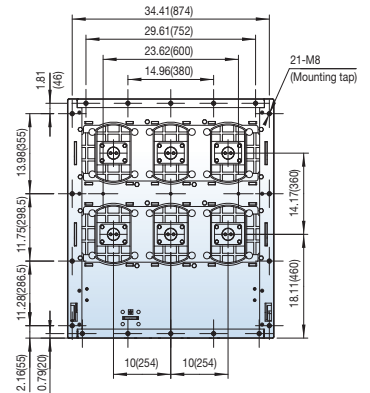
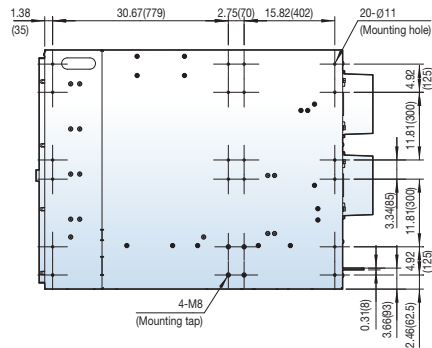
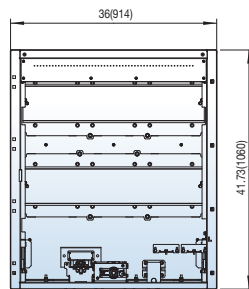
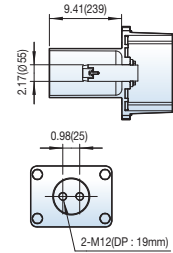
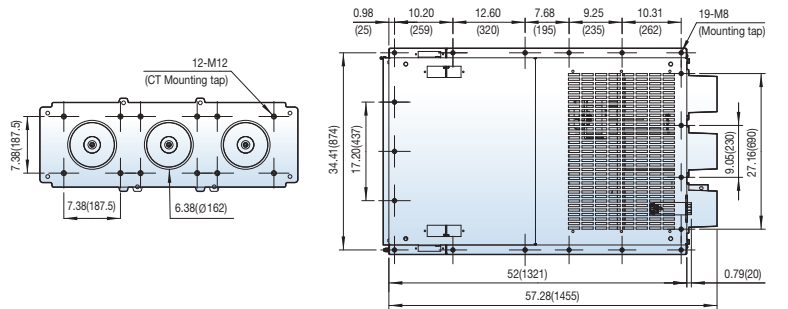

Dimensions

4.76/15kV, 25/31.5/40/50kA, 3000A

UVH type, Drawout type

Type of cradle

- UVCH-05L25C30
- UVCH-05L32C30
- UVCH-05L40C30
- UVCH-05L50C30
- UVCH-15L25C30
- UVCH-15L32C30
- UVCH-15L40C30
- UVCH-15L50C30

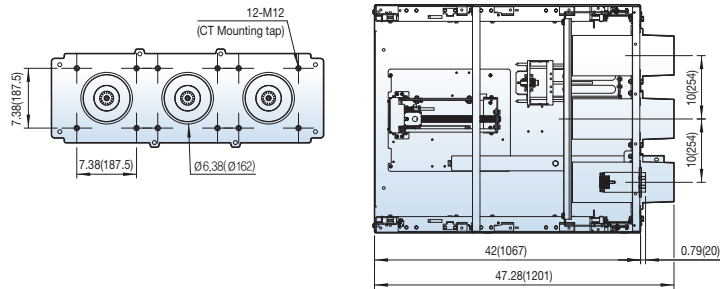

[Unit: inch(mm)]

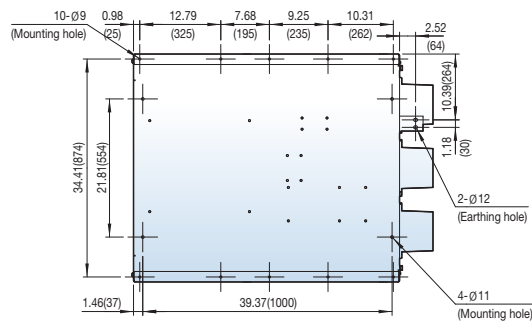
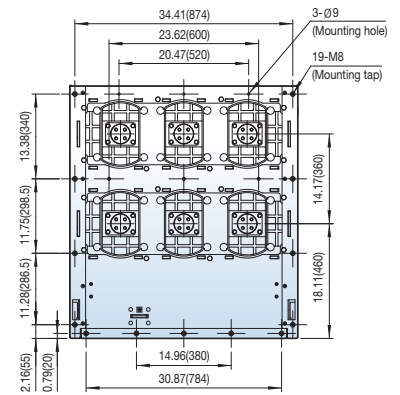
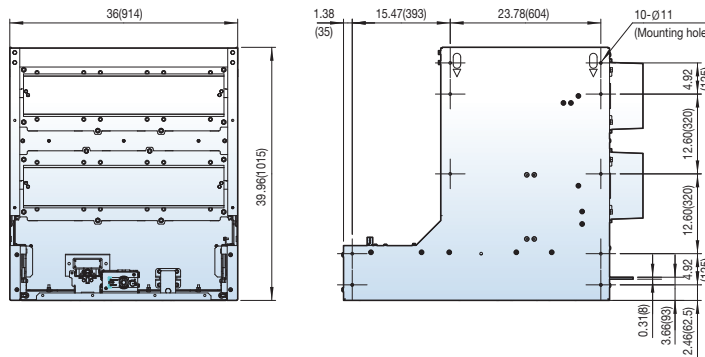
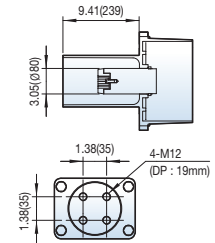

4.76/15kV, 25/31.5/40/50kA, 3000A

UVH type, Drawout type

Type of cradle

- UVCH-05C25C30
- UVCH-05C32C30
- UVCH-05C40C30
- UVCH-05C50C30
- UVCH-15C25C30
- UVCH-15C32C30
- UVCH-15C40C30
- UVCH-15C50C30

[Unit: inch(mm)]

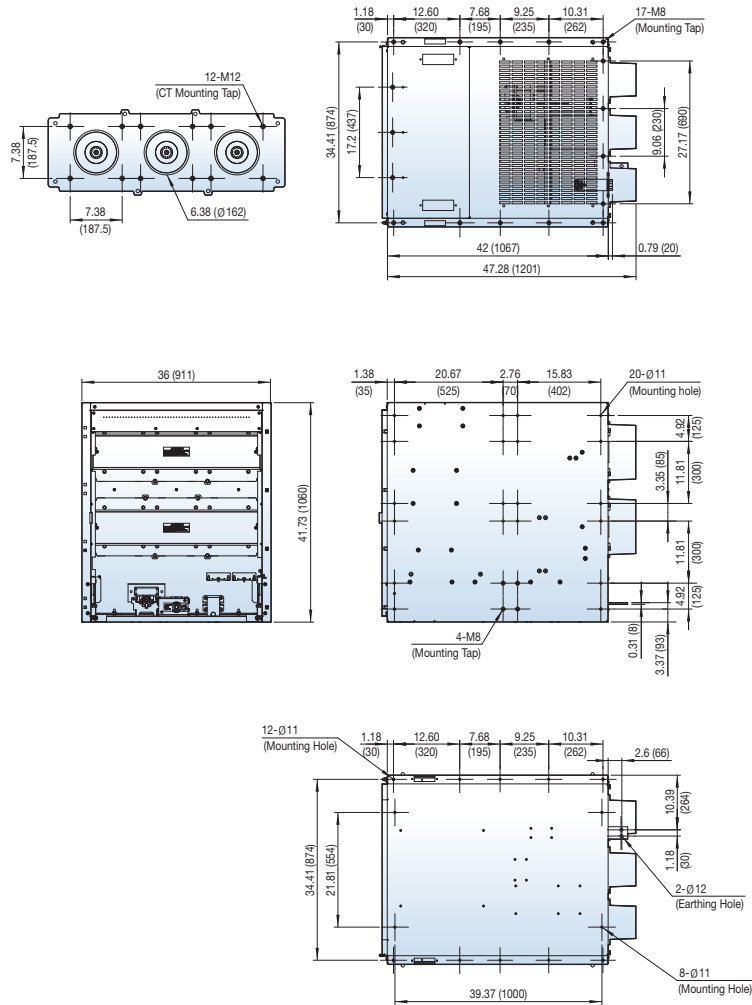

Dimensions

4.76/15kV, 25/31.5/40/50kA, 3000A

UVH type, Drawout type

Type of cradle

- UVCH-05H25C30
- UVCH-05H32C30
- UVCH-05H40C30
- UVCH-05H50C30
- UVCH-15H25C30
- UVCH-15H32C30
- UVCH-15H40C30
- UVCH-15H50C30

[Unit: inch(mm)]

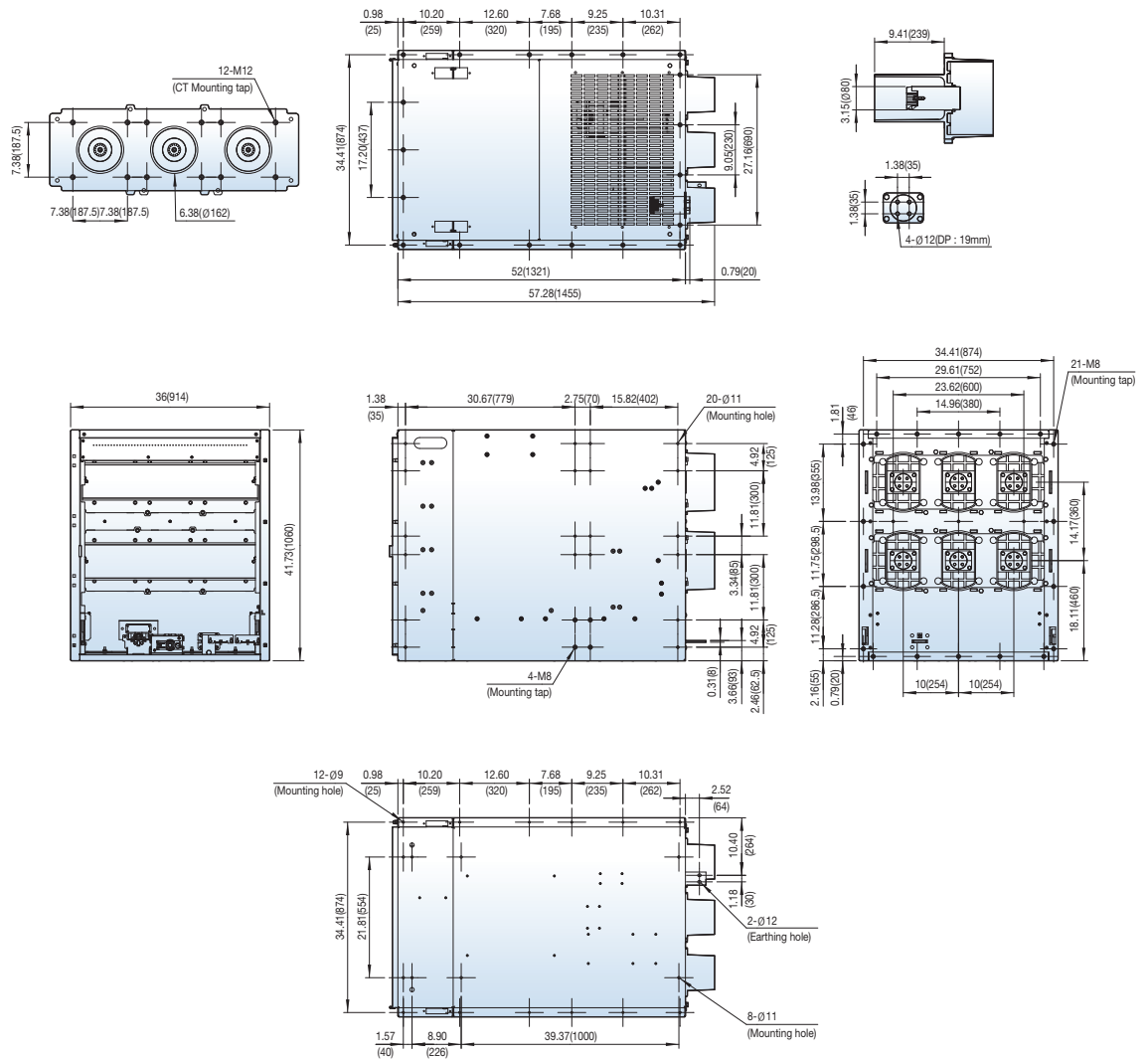

4.76/15kV, 25/31.5/40/50kA, 4000A

UVH type, Drawout type

Type of cradle

- UVCH-05L25L40
- UVCH-05L32L40
- UVCH-05L40L40
- UVCH-05L50L40
- UVCH-15L25L40
- UVCH-15L32L40
- UVCH-15L40L40
- UVCH-15L50L40

[Unit: inch(mm)]

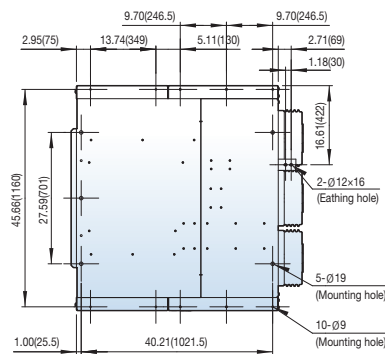
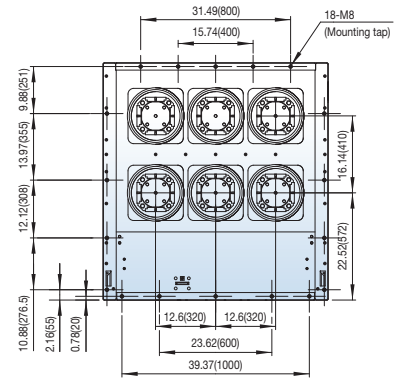
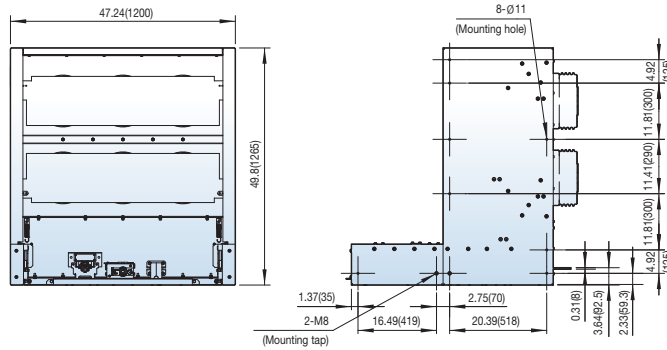
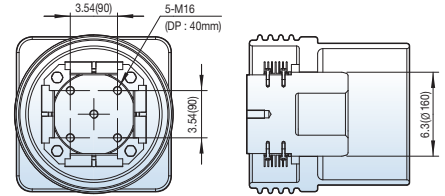
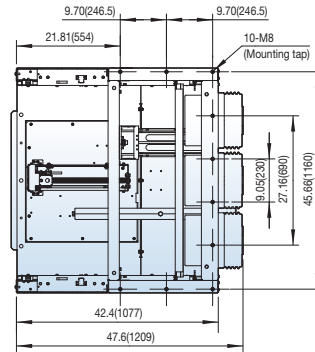

Dimensions

4.76/15kV, 25/31.5/40/50kA, 4000A

UVH type, Drawout type

Type of cradle

- UVCH-05H25L40
- UVCH-05H32L40
- UVCH-05H40L40
- UVCH-05H50L40
- UVCH-15H25L40
- UVCH-15H32L40
- UVCH-15H40L40
- UVCH-15H50L40

[Unit: inch(mm)]

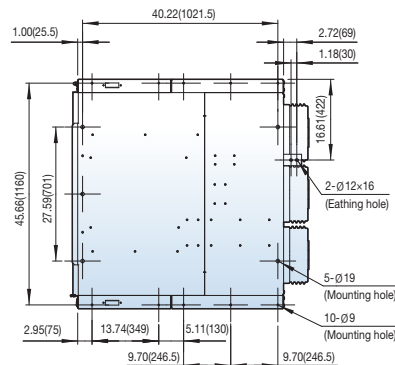
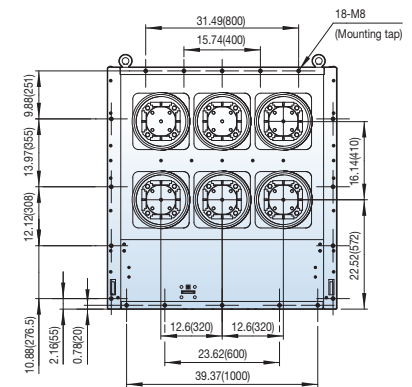
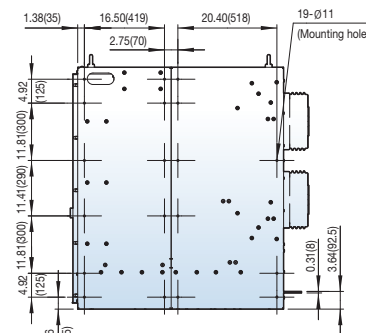
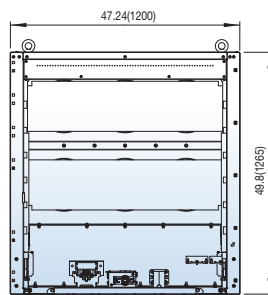
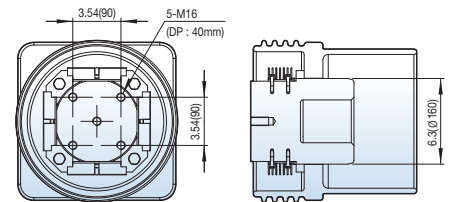
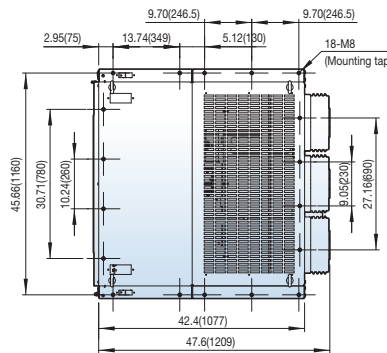

27kV, 31.5/40kA, 1200A

UVH type, Drawout type

Type of cradle

UVCH-27L32C12
UVCH-27L40C12

[Unit: inch(mm)]

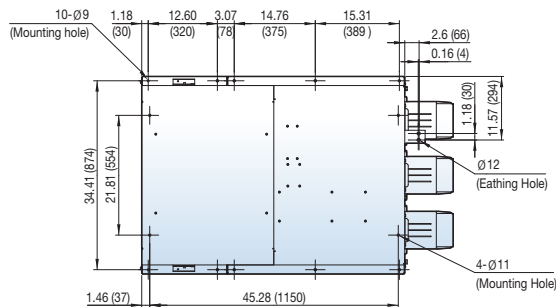
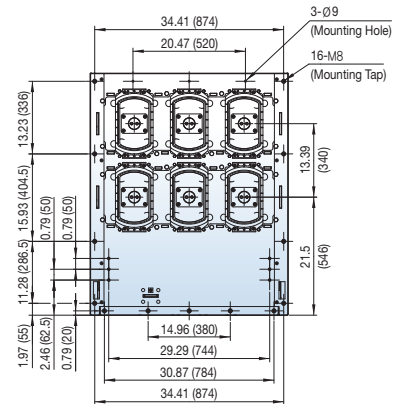
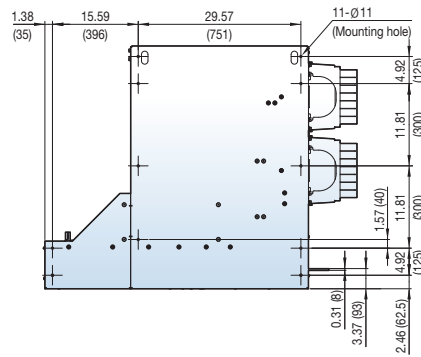
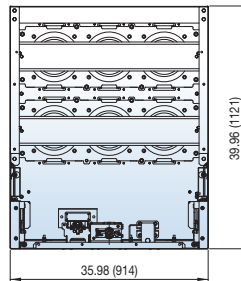
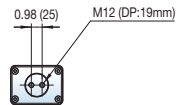
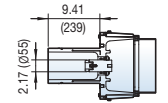
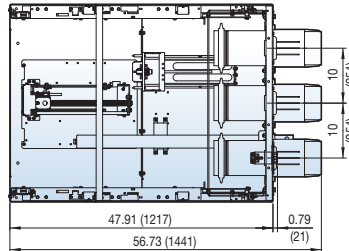
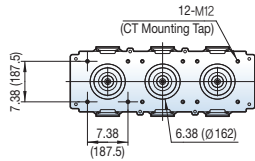

Dimensions

27kV, 31.5/40kA, 2000A

UVH type, Drawout type

Type of cradle

UVCH-27L32C20
UVCH-27L40C20

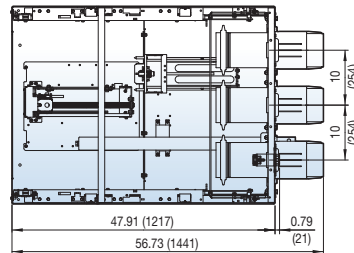
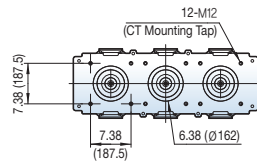

[Unit: inch(mm)]

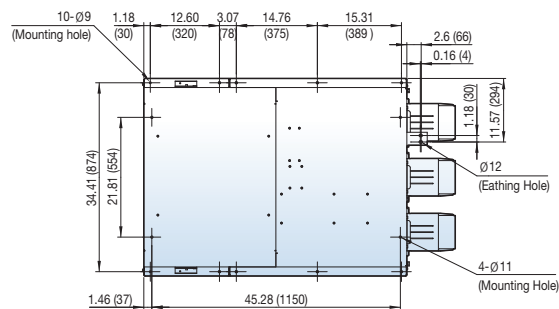
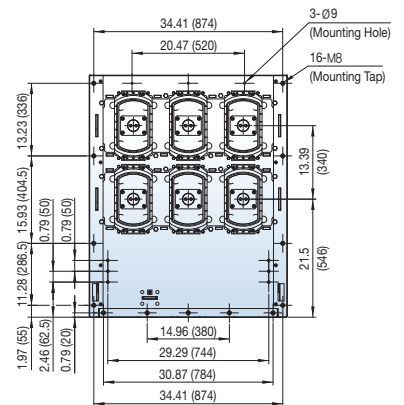
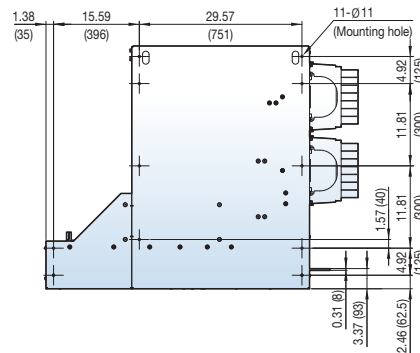
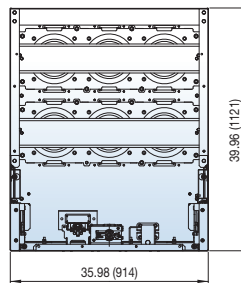
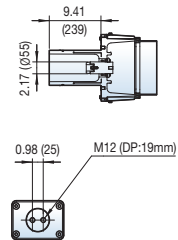

27kV, 25/31.5/40kA, 2500A

UVH type, Drawout type

Type of cradle
 UVCH-27L25C25
 UVCH-27L32C25
 UVCH-27L40C25

[Unit: inch(mm)]

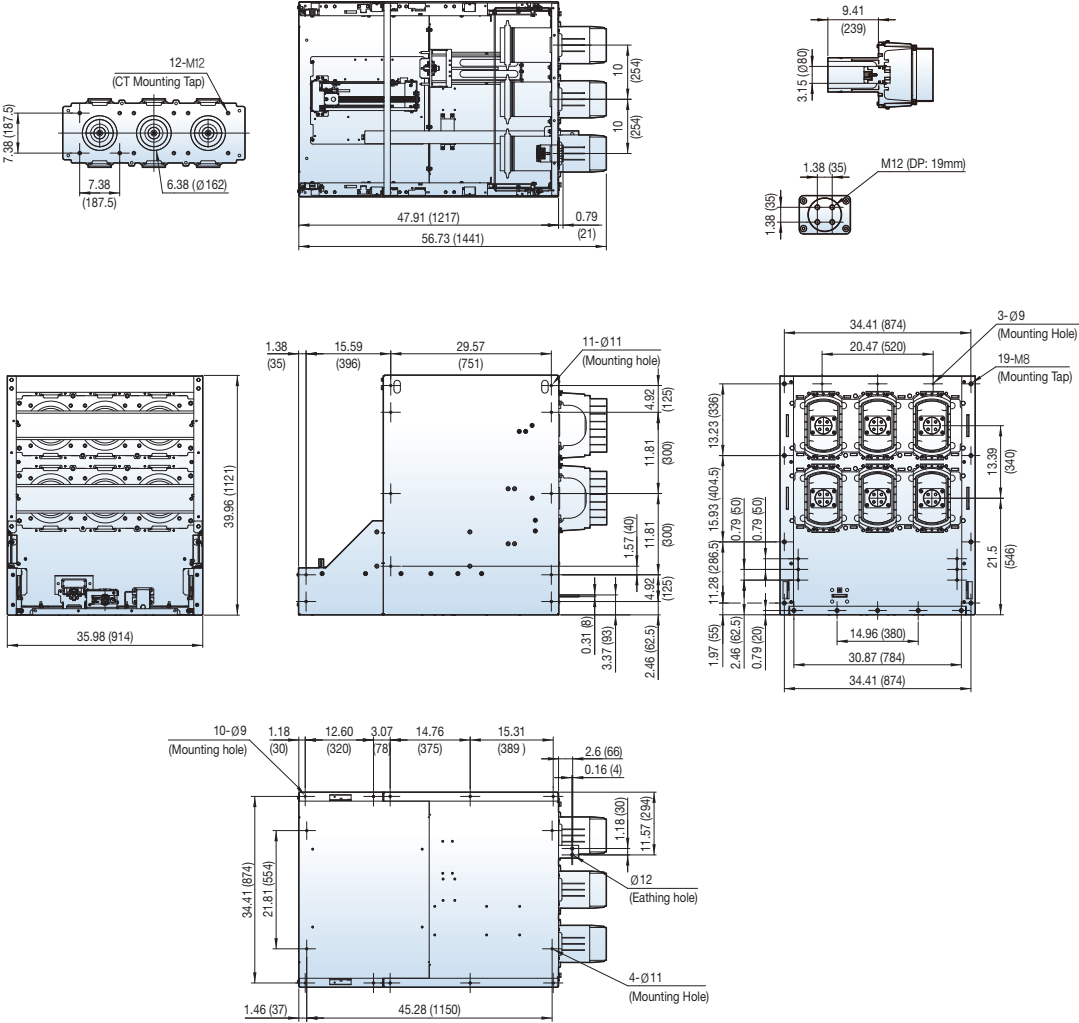

Dimensions

27kV, 25/31.5/40kA, 2750A

UVH type, Drawout type

Type of cradle

- UVCH-27L25C28
- UVCH-27L32C28
- UVCH-27L40C28

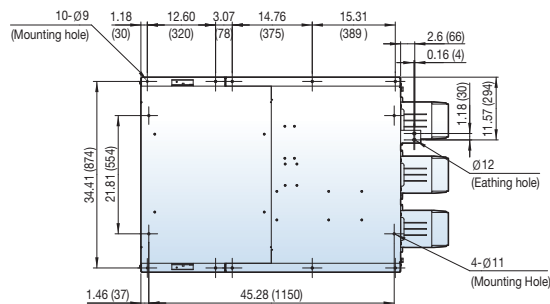
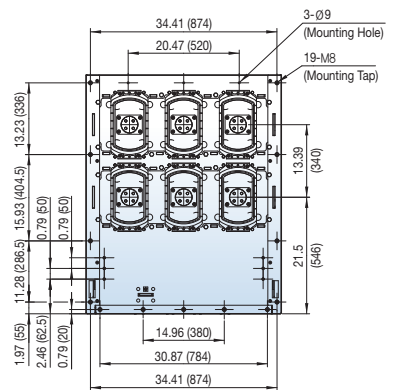
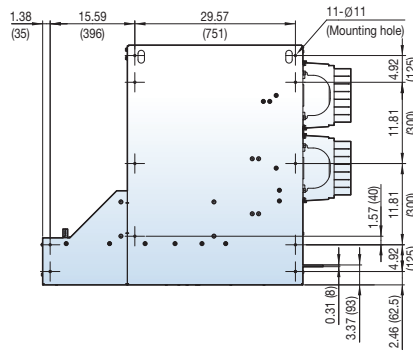
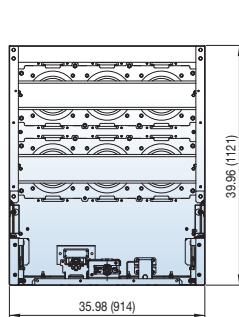
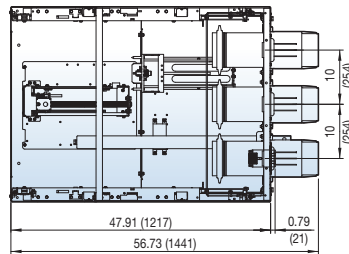
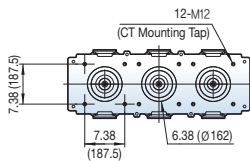

[Unit: inch(mm)]

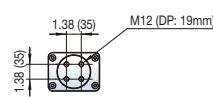
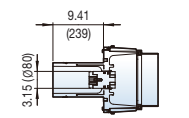

27kV, 31.5/40kA, 1200A

UVH type, Drawout type

Type of cradle

UVCH-27C32C12
UVCH-27C40C12

[Unit: inch(mm)]

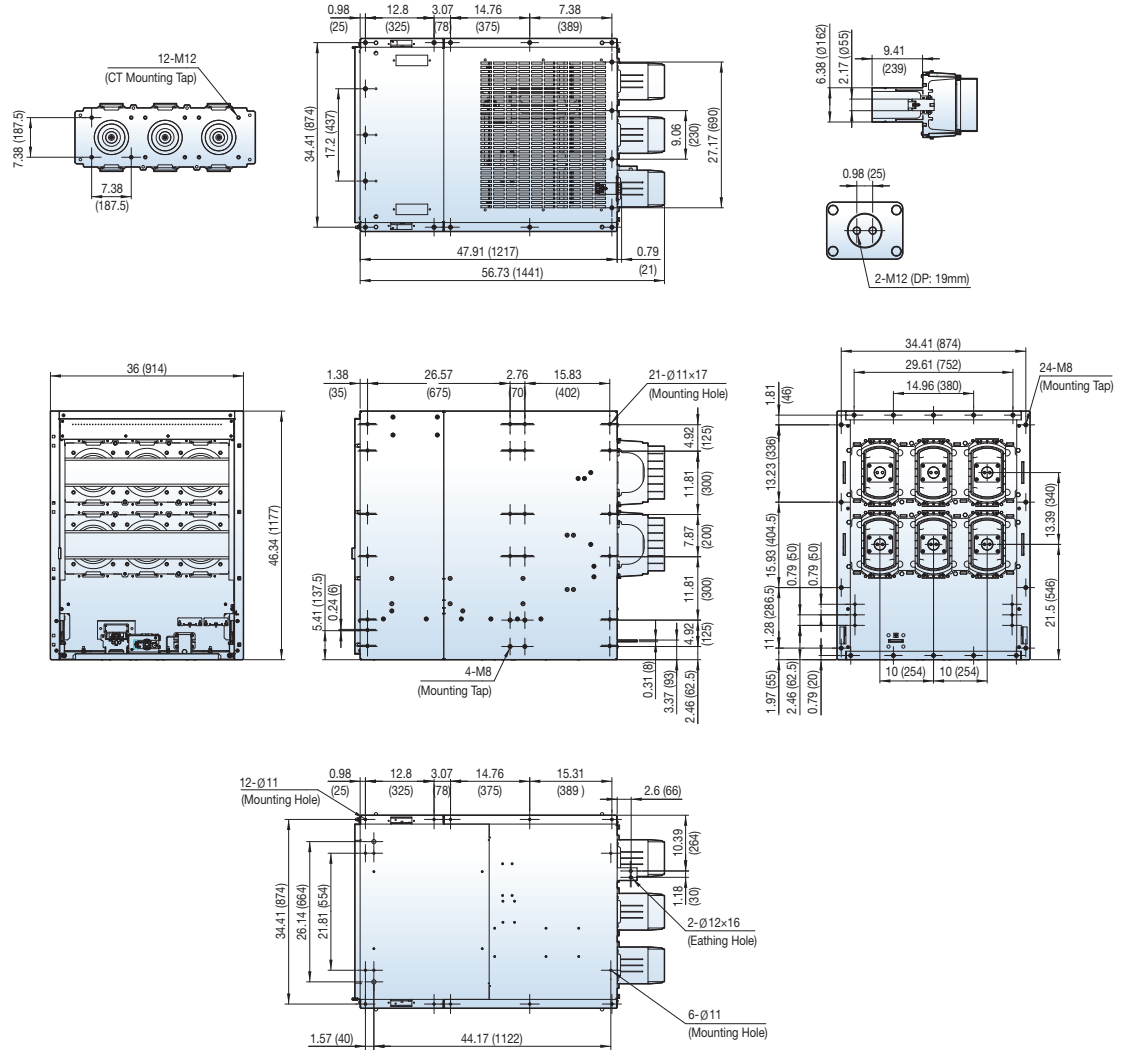

Dimensions

27kV, 31.5/40kA, 2000A

UVH type, Drawout type

Type of cradle

UVCH-27C32C20
UVCH-27C40C20

[Unit: inch(mm)]

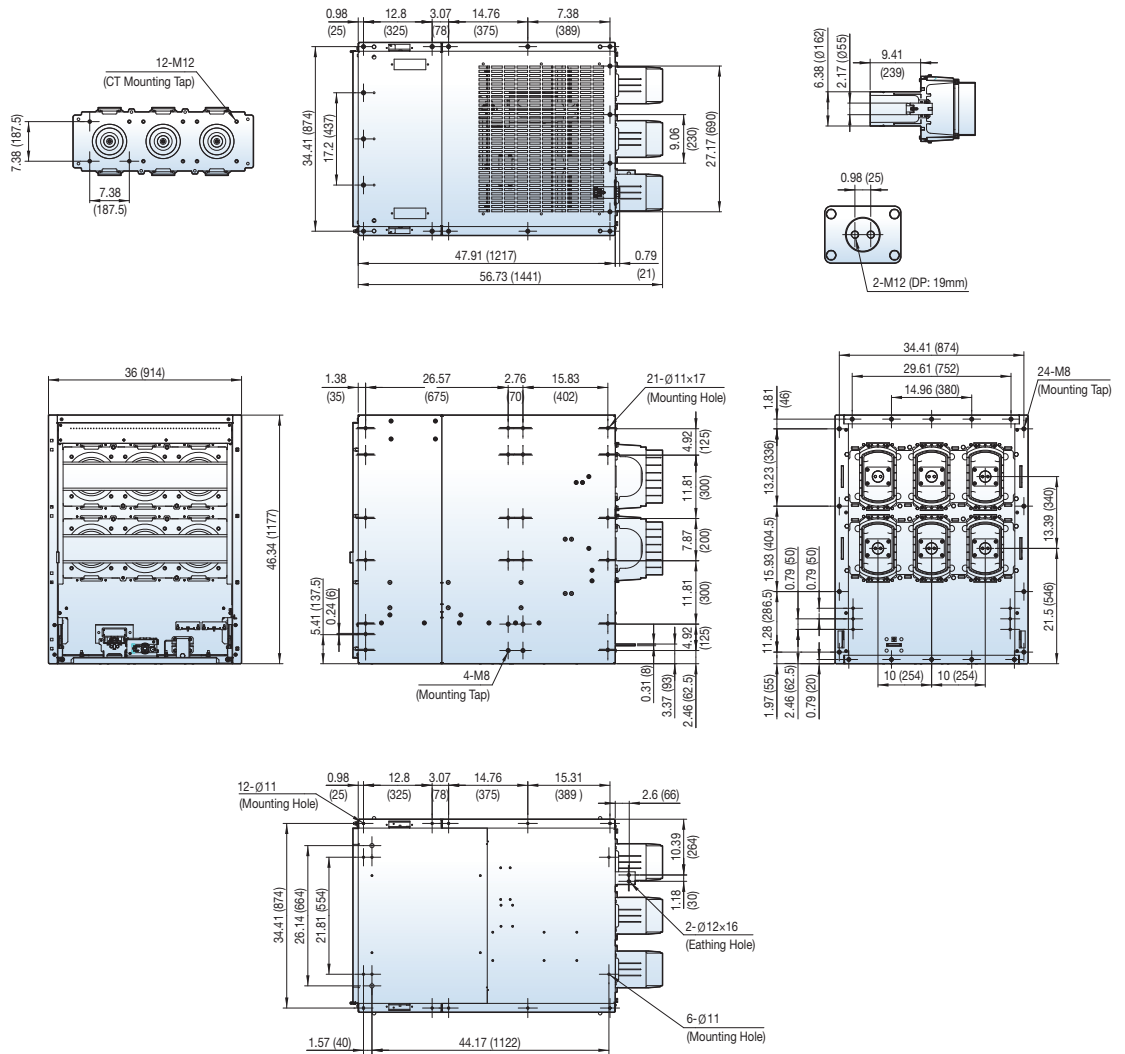

27kV, 25/31.5/40kA, 2500A

UVH type, Drawout type

Type of cradle

- UVCH-27C25C25
- UVCH-27C32C25
- UVCH-27C40C25

[Unit: inch(mm)]

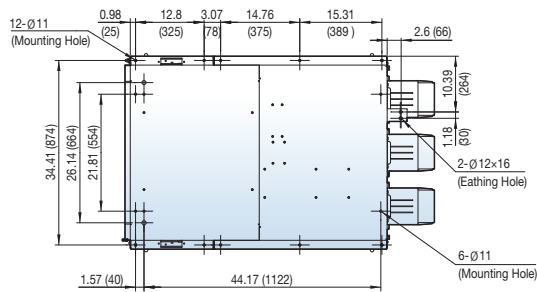
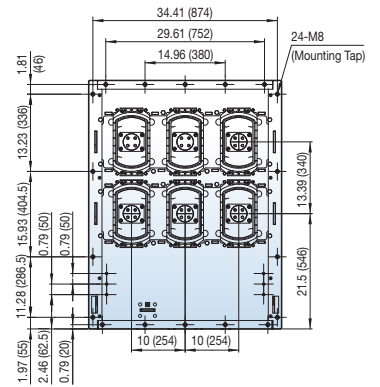
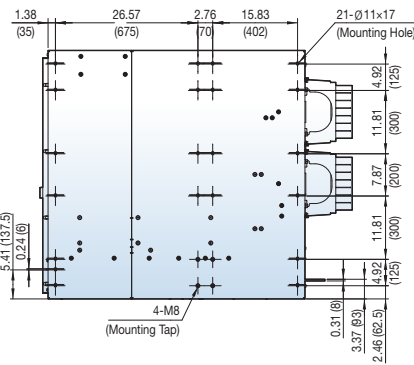
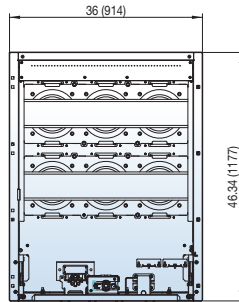
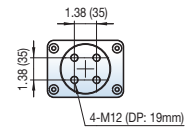
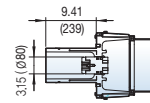
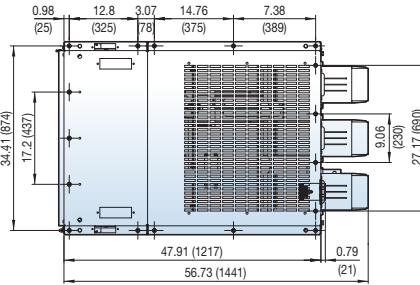
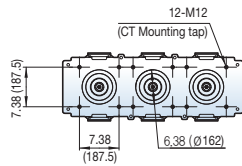

Dimensions

27kV, 25/31.5/40kA, 2750A

UVH type, Drawout type

Type of cradle

- UVCH-27C25C28
- UVCH-27C32C28
- UVCH-27C40C28

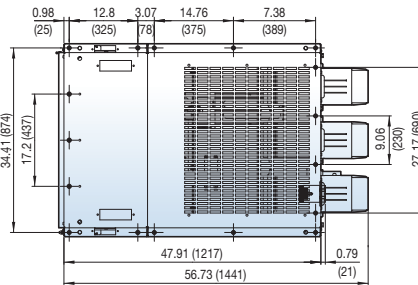
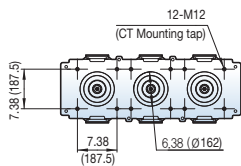

[Unit: inch(mm)]

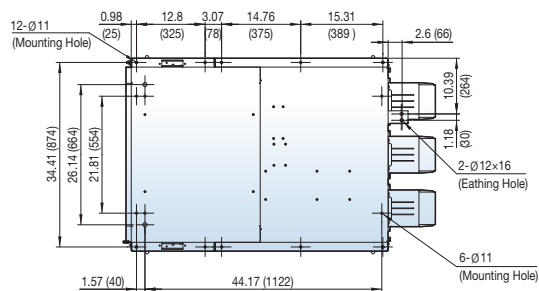
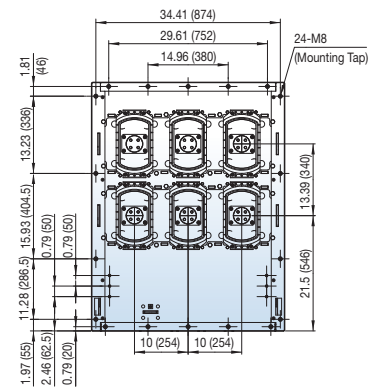
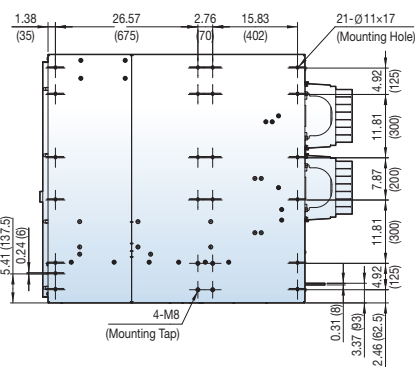
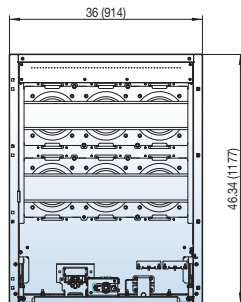
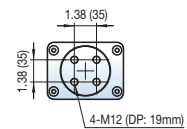
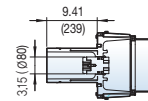

27kV, 31.5/40kA, 1200A

UVH type, Drawout type

Type of cradle

UVCH-27H32C12
UVCH-27H40C12

[Unit: inch(mm)]

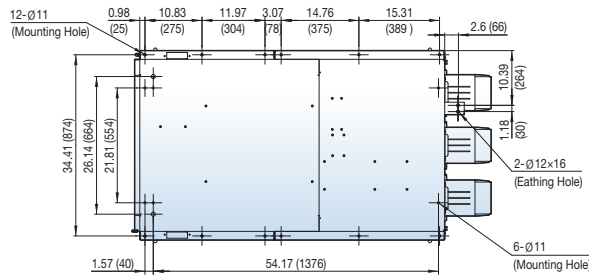
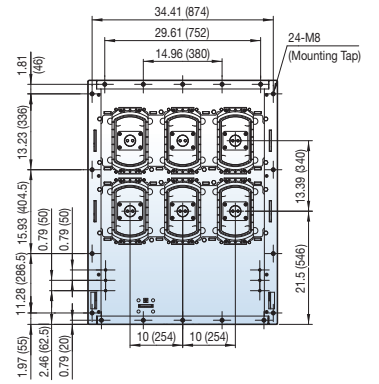
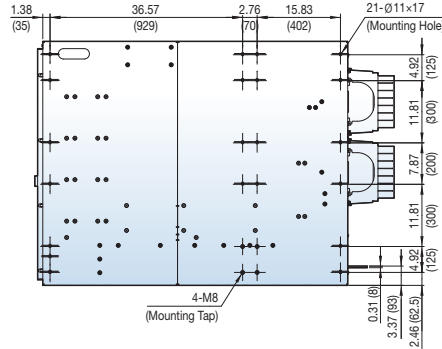
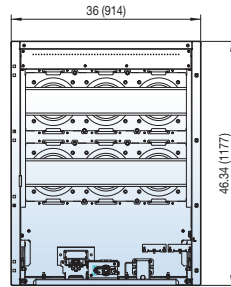
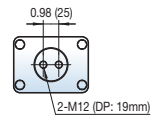
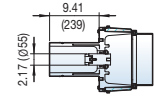
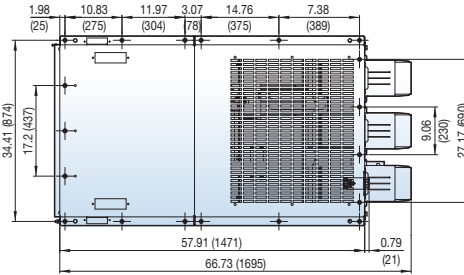
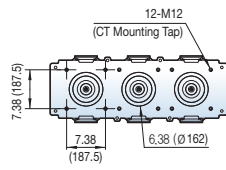

Dimensions

27kV, 31.5/40kA, 2000A

UVH type, Drawout type

Type of cradle

UVCH-27H32C20
UVCH-27H40C20

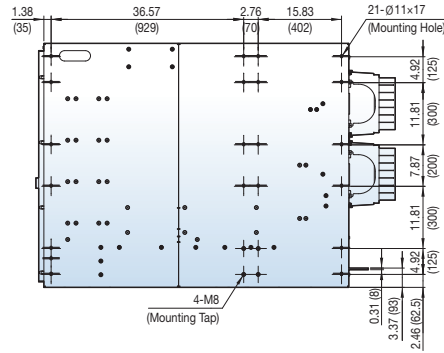
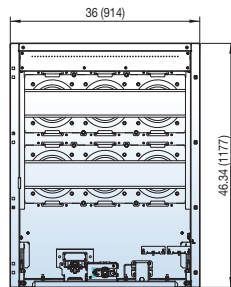
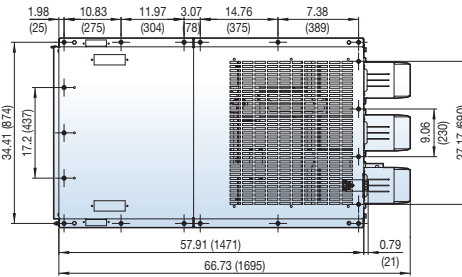
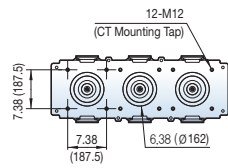

[Unit: inch(mm)]

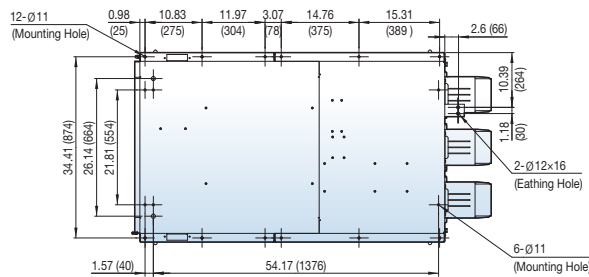
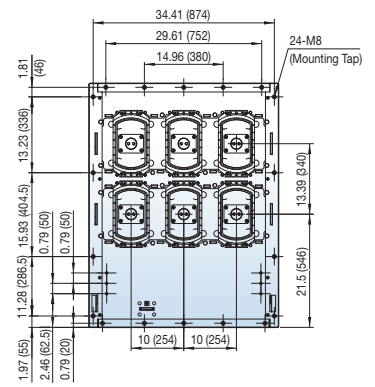
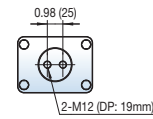
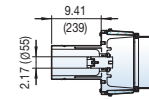

27kV, 25/31.5/40kA, 2500A

UVH type, Drawout type

Type of cradle

- UVCH-27H25C25
- UVCH-27H32C25
- UVCH-27H40C25

[Unit: inch(mm)]

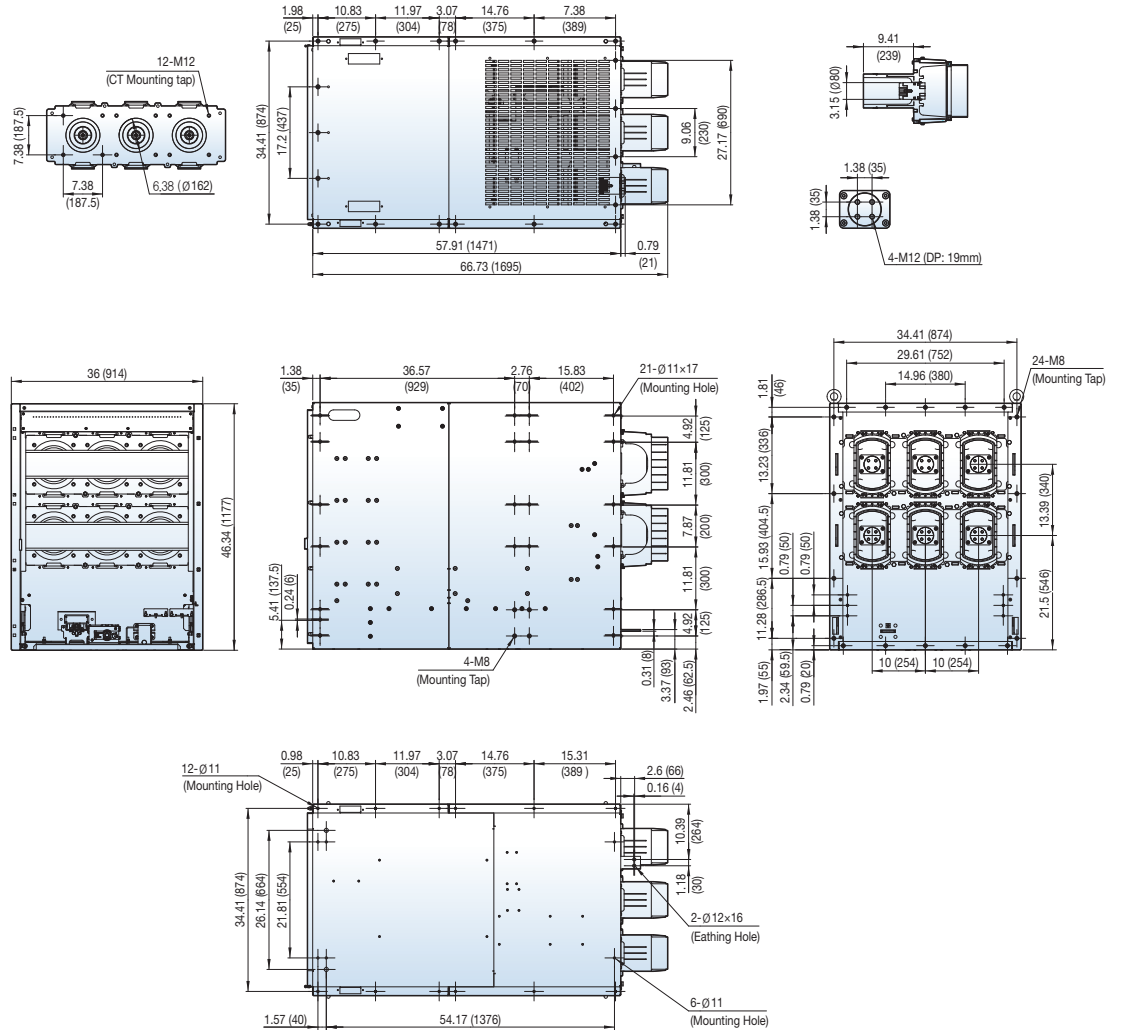

Dimensions

27kV, 25/31.5/40kA, 2750A

UVH type, Drawout type

Type of cradle

- UVCH-27H25C28
- UVCH-27H32C28
- UVCH-27H40C28

[Unit: inch(mm)]

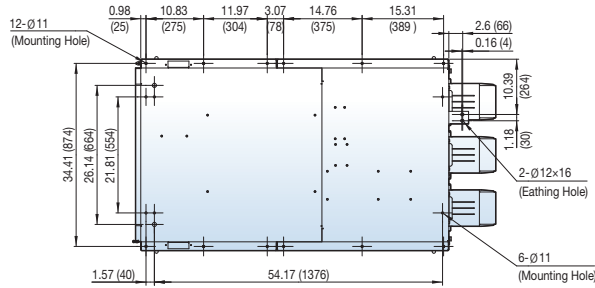
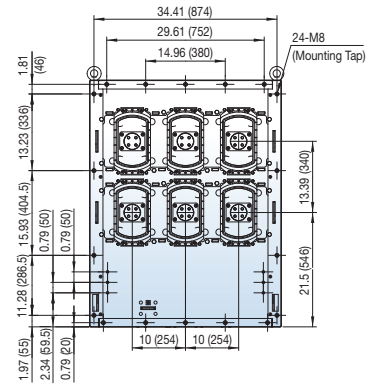
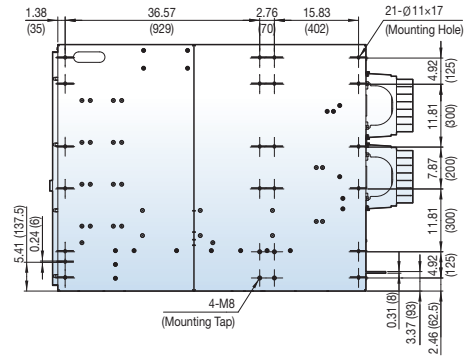
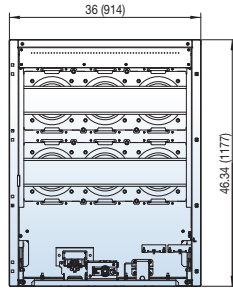
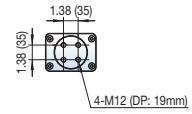
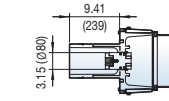
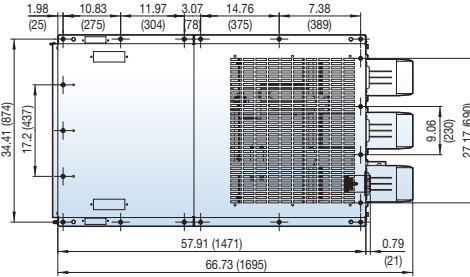
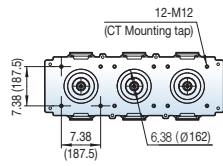

38kV, 31.5/40kA, 1200/2000A

UVH type, Drawout type

Type of circuit breaker

- UVCH-38H32E12
- UVCH-38H32E20
- UVCH-38H40E12
- UVCH-38H40E20

[Unit: inch(mm)]

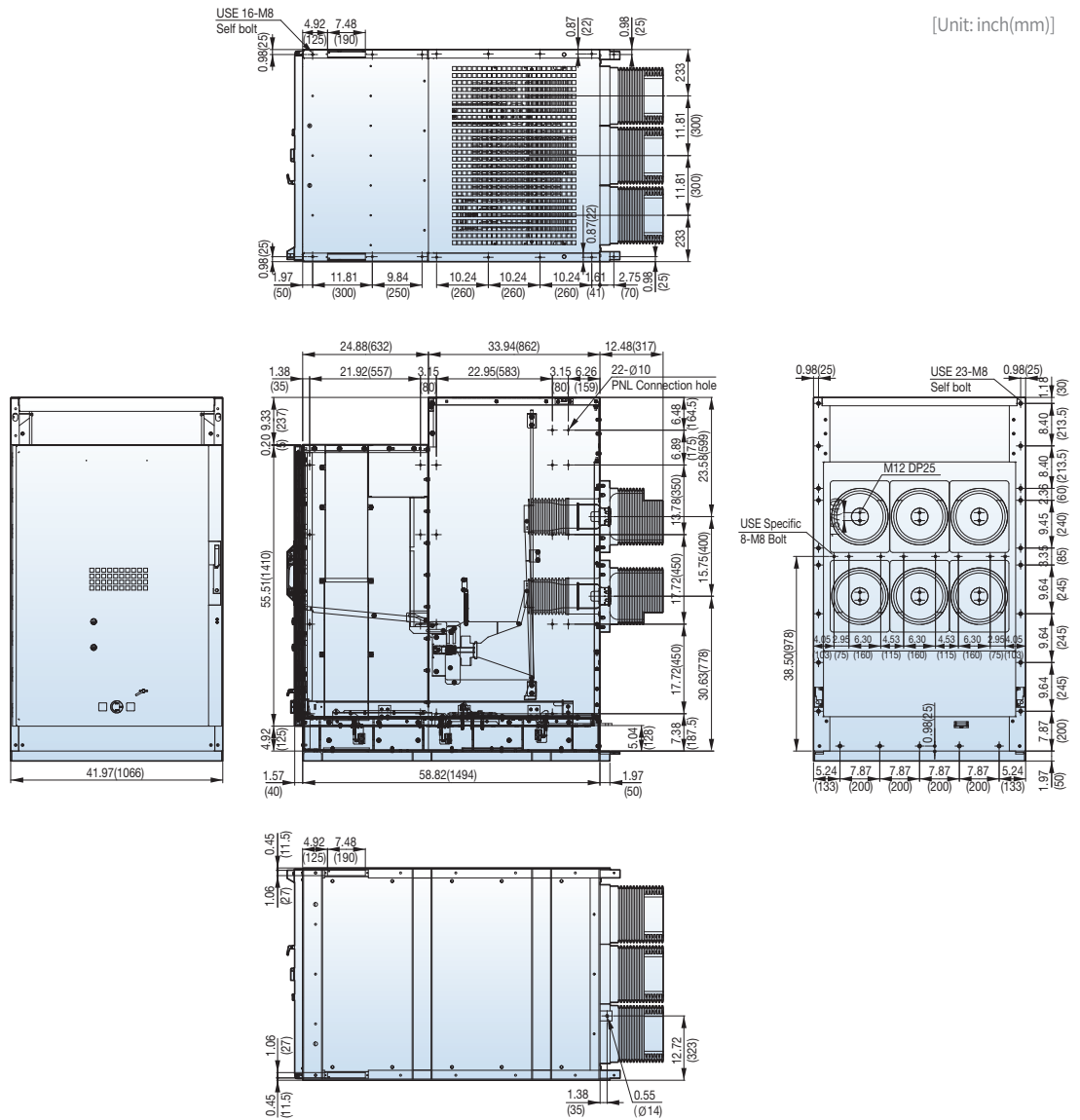

Memo

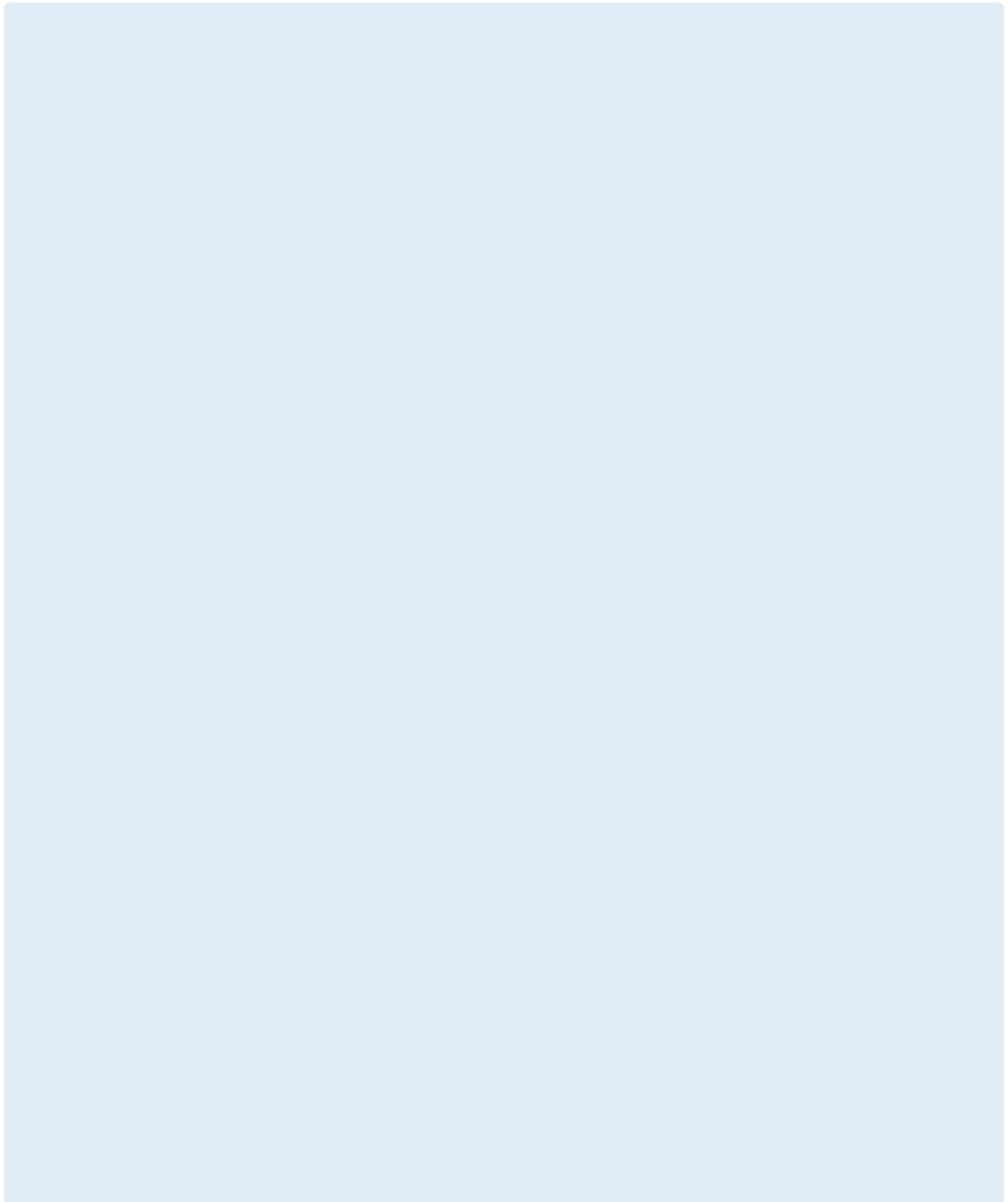

Susol UVGT

Simple Manual Device type



Contents

▪ Ratings and description	130
▪ Selection guide of ground and test devices	131
▪ Dimensions	132

Ratings and description

UVGT, Simple manual device type



UVGT-15Ms

GT type		UVGT-15Ms			
Rated voltage	Ur (kV)	4.76/15			
Rated withstand voltage	Power frequency (1min)	Ud (kV)	19/36		
	Lightening impulse (1.2×50µs)	Up (kV)	60/95		
Rated short-time withstand current	Isc (kA)	25	25	31.5	31.5
Rated normal current	Ir (A)	1200	2000	1200	2000
Rated frequency	fr (Hz)	60	60	60	60
Rated momentary withstand current	Ip (kA) at 60 Hz	65	65	81.9	81.9

Description for ground and test device type

UVGT type

UVGT		15	Ms	32	A	12					
Basic model name		Rated voltage (kV)		Version		Interrupting current (kA)		Phase distance/Compatibility		Rated current (A)	
UVGT	Ground Truck	05	4.76	Ms	Simple manual device	25	25	R	5.9"(150mm)	12	1200A
		15	15			32	31.5	S	8.27"(210mm)	20	2000A
		38	38	Ms	Simple manual device	32	31.5	E	11.8"(300mm)	12	1200A
						40	40			20	2000A

Selection table of ground and test devices

Upper terminal only

Type of GT	Related VCB	Outline dimension H×W×D [mm]	Ordering sales code	Dimension page
UVGT-15Ms25R12-AB	UVL-05H25R12 UVL-15H25R12	687.8×503×642	Contact LS ELECTRIC sales person	132
UVGT-15Ms25S12-AB	UVL-05H25S12 UVL-15H25S12	687.8×653×642		132
UVGT-15Ms25S20-AB	UVL-05H25B20 UVL-15H25B20	687.8×653×642		133
UVGT-15Ms32R12-AB	UVL-05H32R12 UVL-15H32R12	687.8×503×642		132
UVGT-15Ms32S12-AB	UVL-05H32S12 UVL-15H32S12	687.8×653×642		132
UVGT-15Ms32S20-AB	UVL-05H32B20 UVL-15H32B20	687.8×653×642		103
UVGT-38Ms32E12-AB	UVH-38H32E12	1096×986×990.7		134
UVGT-38Ms32E20-AB	UVH-38H32E20	1096×986×990.7		134
UVGT-38Ms40E12-AB	UVH-38H40E12	1096×986×990.7		134
UVGT-38Ms40E20-AB	UVH-38H40E20	1096×986×990.7		134

Lower terminal only

Type of GT	Related VCB	Outline dimension H×W×D [mm]	Ordering sales code	Dimension page
UVGT-15Ms25R12-AC	UVL-05H25R12 UVL-15H25R12	687.8×503×642	Contact LS ELECTRIC sales person	132
UVGT-15Ms25S12-AC	UVL-05H25S12 UVL-15H25S12	687.8×653×642		132
UVGT-15Ms25S20-AC	UVL-05H25B20 UVL-15H25B20	687.8×653×642		133
UVGT-15Ms32R12-AC	UVL-05H32R12 UVL-15H32R12	687.8×503×642		132
UVGT-15Ms32S12-AC	UVL-05H32S12 UVL-15H32S12	687.8×653×642		132
UVGT-15Ms32S20-AC	UVL-05H32B20 UVL-15H32B20	687.8×653×642		133
UVGT-38Ms32E12-AC	UVH-38H32E12	1096×986×990.7		134
UVGT-38Ms32E20-AC	UVH-38H32E20	1096×986×990.7		134
UVGT-38Ms40E12-AC	UVH-38H40E12	1096×986×990.7		134
UVGT-38Ms40E20-AC	UVH-38H40E20	1096×986×990.7		134

Ground connection system

Type of GT	Related VCB	Outline dimension H×W×D [mm]	Ordering sales code	Dimension page
UVGT-15Ms25R12-AD	UVL-05H25R12 UVL-15H25R12	687.8×503×642	Contact LS ELECTRIC sales person	132
UVGT-15Ms25S12-AD	UVL-05H25S12 UVL-15H25S12	687.8×653×642		132
UVGT-15Ms25S20-AD	UVL-05H25B20 UVL-15H25B20	687.8×653×642		133
UVGT-15Ms32R12-AD	UVL-05H32R12 UVL-15H32R12	687.8×503×642		132
UVGT-15Ms32S12-AD	UVL-05H32S12 UVL-15H32S12	687.8×653×642		132
UVGT-15Ms32S20-AD	UVL-05H32B20 UVL-15H32B20	687.8×653×642		133
UVGT-38Ms32E12-AD	UVH-38H32E12	1096×986×990.7		134
UVGT-38Ms32E20-AD	UVH-38H32E20	1096×986×990.7		134
UVGT-38Ms40E12-AD	UVH-38H40E12	1096×986×990.7		134
UVGT-38Ms40E20-AD	UVH-38H40E20	1096×986×990.7		134

Dimensions

4.76/15kV 25/31.5kA 1200A

UVGT type, Drawout type

Type of ground truck device

UVGT-15Ms25R12
UVGT-15Ms32R12

[Unit: inch(mm)]

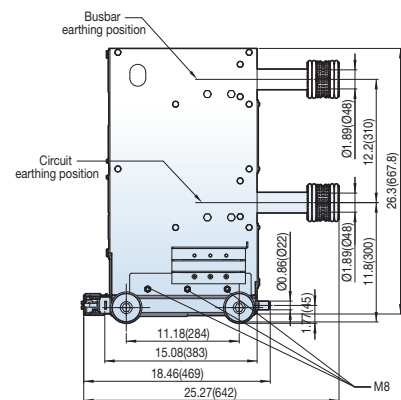
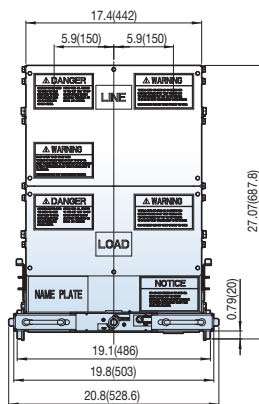
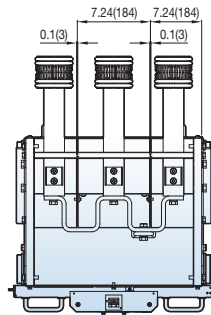

Type of ground truck device

UVGT-15Ms25S12
UVGT-15Ms32S12

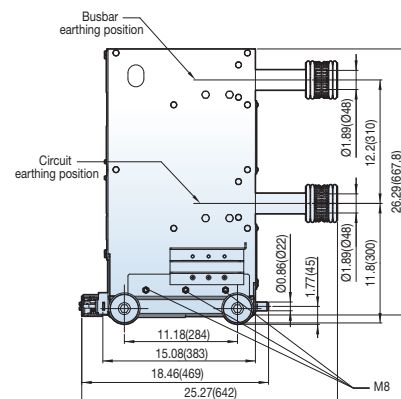
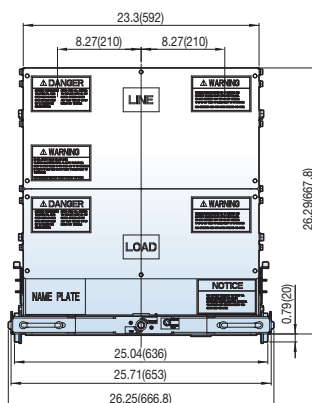
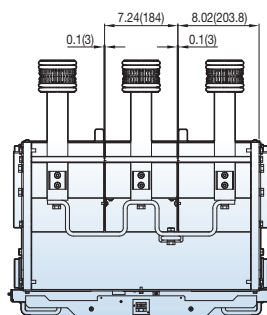

4.76/15kV 25/31.5kA 2000A

UVGT type, Drawout type

Type of ground truck device

- UVGT-15Ms25S20
- UVGT-15Ms32S20

[Unit: inch(mm)]

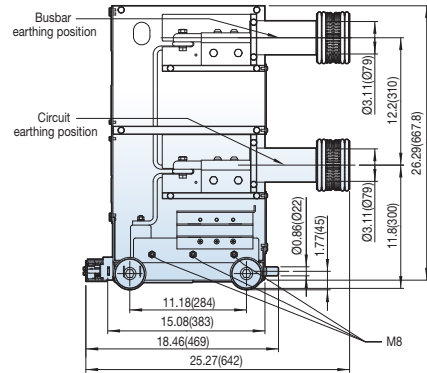
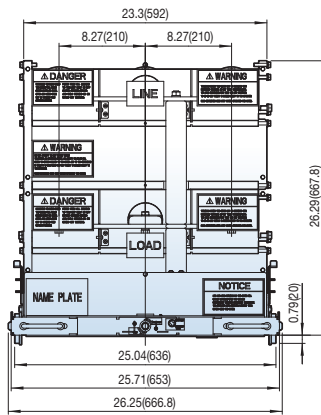
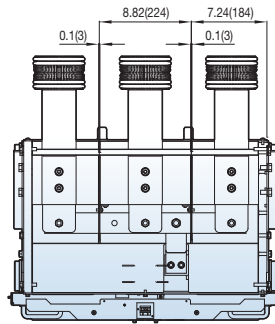

Dimensions

38kV 31.5/40kA 1200/2000A

UVGT type, Drawout type

Type of ground truck device

- UVGT-38Ms32E12
- UVGT-38Ms32E20
- UVGT-38Ms40E12
- UVGT-38Ms40E20

[Unit: inch(mm)]

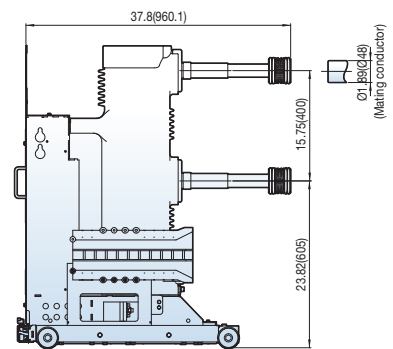
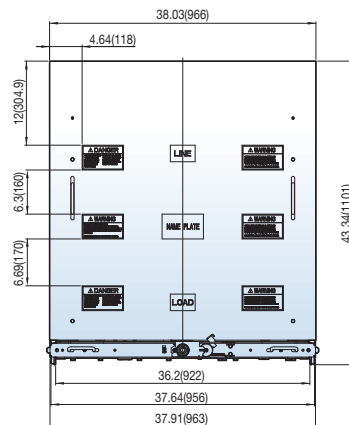
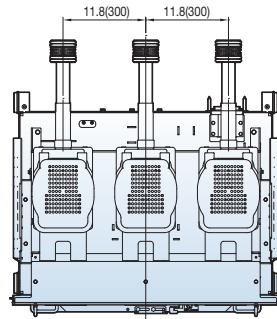

Susol UCGT

Simple Manual Device type



Contents

▪ Ratings and description	136
▪ Selection guide of ground and test devices	139
▪ Dimensions	145

Ratings and description

UCGT, Simple manual device type

UCGT-15Ms

GT type		UCGT-15Ms							
Rated voltage	Ur (kV)	4.76/15							
Rated withstand voltage	Power frequency (1min)	Ud (kV)	19/36						
	Lightening impulse (1.2×50µs)	Up (kV)	60/95						
Rated short-time withstand current	Isc (kA)	25/31.5	25/31.5	40	50	40/50	25/31.5/40/50	25/31.5/40/50	
Rated normal current	Ir (A)	1200	2000	1200	1200	2000	3000	4000	
Rated frequency	fr (Hz)	60	60	60	60	60	60	60	
Rated momentary withstand current	Ip (kA) at 60 Hz	65/81.9	65/81.9	104	130	104/130	65/81.9/104/130	65/81.9/104/130	

UCGT-27Ms

GT type		UCGT-27Ms									
Rated voltage	Ur (kV)	27									
Rated withstand voltage	Power frequency (1min)	Ud (kV)	60								
	Lightening impulse (1.2×50µs)	Up (kV)	125								
Rated short-time withstand current	Isc (kA)	25	31.5				40				
Rated normal current	Ir (A)	2500	2750	1200	2000	2500	2750	1200	2000	2500	2750
Rated frequency	fr (Hz)	60	60	60	60	60	60	60	60	60	60
Rated short-circuit making current	Ip (kA) at 60 Hz	65	65	81.9	81.9	81.9	81.9	104	104	104	104
Rated short-time withstand current	Ik (kA)	25	25	31.5	31.5	31.5	31.5	40	40	40	40

Description for ground and test device type

UCGT type

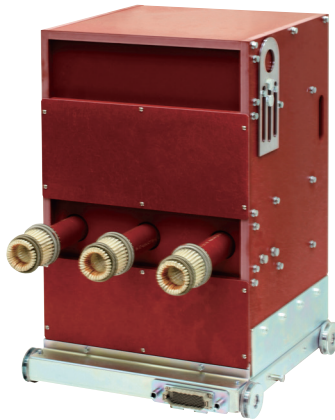
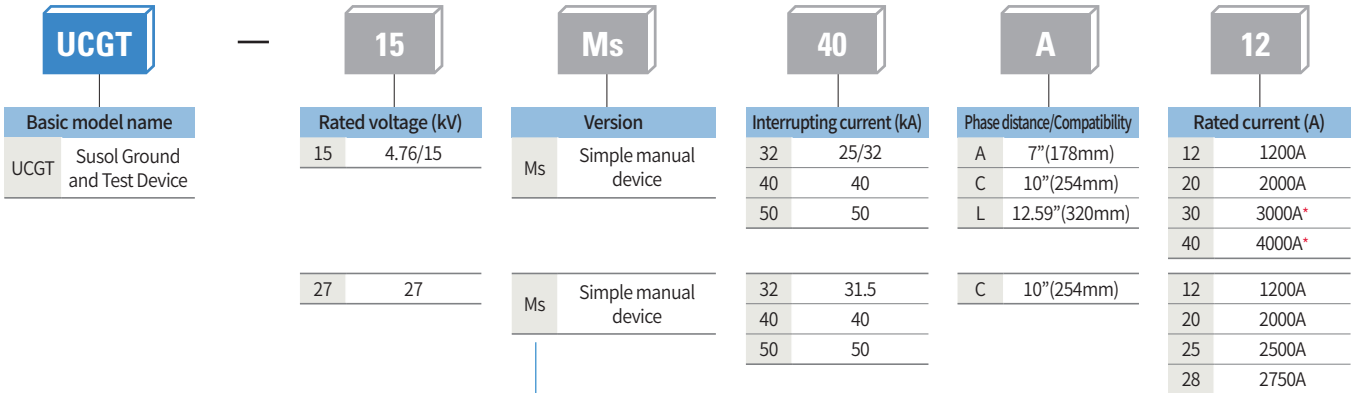

* 3000/4000A have only 1 phase distance
3000A: 10"(254mm)
4000A: 12.59"(320mm)

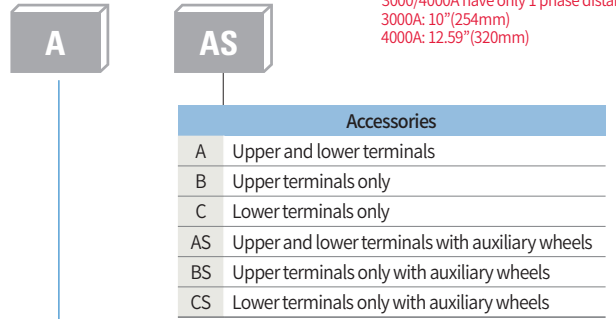

1 Type of cradle
(select from the next pages)

3 Accessories

Ratings and description

Order form for ground & test device (UCGT)

Please select only one of the items on the same horizontal line.

UCGT, Ground & Test Device, Drawout type

Select specification (4.76/15kV)			
Rated voltage			
<input type="radio"/> 4.76kV	<input type="radio"/> 15kV		
Version			
<input type="radio"/> Ms			
Interrupting current			
<input type="radio"/> 25kA	<input type="radio"/> 31.5kA	<input type="radio"/> 40kA	<input type="radio"/> 50kA
Phase distance/Compatibility			
<input type="radio"/> 7"(178mm)	<input type="radio"/> 10"(254mm)	<input type="radio"/> 12.59"(320mm)	
<i>* 3000/4000A have only 1 phase distance. 3000A: 10"(254mm), 4000A: 12.59"(320mm)</i>			
Rated current			
<input type="radio"/> 1200A	<input type="radio"/> 2000A	<input type="radio"/> 3000A	<input type="radio"/> 4000A
Terminal set			
<input type="radio"/> Upper and lower terminals	<input type="radio"/> Upper terminals only	<input type="radio"/> Lower terminals only	
Auxiliary wheels			
<input type="radio"/> With auxiliary wheels	<input type="radio"/> Without auxiliary wheels		

Please select only one of the items on the same horizontal line.

UCGT, Ground & Test Device, Drawout type

Select specification (27kV)			
Rated voltage			
<input type="radio"/> 27kV			
Version			
<input type="radio"/> Ms			
Interrupting current			
<input type="radio"/> 25kA	<input type="radio"/> 31.5kA	<input type="radio"/> 40kA	
<i>* 1200/2000A does not have 25kA.</i>			
Phase distance/Compatibility			
<input type="radio"/> 10"(254mm)			
Rated current			
<input type="radio"/> 1200A	<input type="radio"/> 2000A	<input type="radio"/> 2500A	<input type="radio"/> 2750A
<i>* 1200/2000A does not have 25kA.</i>			
Terminal set			
<input type="radio"/> Upper and lower terminals	<input type="radio"/> Upper terminals only	<input type="radio"/> Lower terminals only	
Auxiliary wheels			
<input type="radio"/> With auxiliary wheels	<input type="radio"/> Without auxiliary wheels		

Selection table of ground and test devices

Upper and lower terminals

Type of GT	Related VCB	Outline dimension H×W×D [inch/(mm)]	Dimension page
UCGT-05Ms25A12-AA UCGT-05Ms32A12-AA UCGT-15Ms25A12-AA UCGT-15Ms32A12-AA	UVM-05H25A12 UVM-05H32A12 UVM-15H25A12 UVM-15H32A12	26.26×22×28.85 (677×559×732.7)	145
UCGT-05Ms25A20-AA UCGT-05Ms32A20-AA UCGT-15Ms25A20-AA UCGT-15Ms32A20-AA	UVM-05H25A20 UVM-05H32A20 UVM-15H25A20 UVM-15H32A20	26.26×22×28.85 (677×559×732.7)	146
UCGT-05Ms25C12-AA UCGT-05Ms32C12-AA UCGT-15Ms25C12-AA UCGT-15Ms32C12-AA	UVM-05H25C12 UVM-05H32C12 UVM-15H25C12 UVM-15H32C12	31.65×32×28.85 (677×813×732.7)	145
UCGT-05Ms25C20-AA UCGT-05Ms32C20-AA UCGT-15Ms25C20-AA UCGT-15Ms32C20-AA	UVM-05H25C20 UVM-05H32C20 UVM-15H25C20 UVM-15H32C20	31.62×32×28.85 (677×813×732.7)	146
UCGT-05Ms40A12-AA UCGT-15Ms40A12-AA	UVH-05H40A12 UVH-15H40A12	31.65×22×28.85 (804×559×732.7)	147
UCGT-15Ms40C12-AA UCGT-05Ms40C12-AA	UVH-05H40C12 UVH-15H40C12	31.62×32×28.85 (804×813×732.7)	147
UCGT-05Ms50A12-AA UCGT-15Ms50A12-AA	UVH-05H50A12 UVH-15H50A12	31.65×22×28.85 (804×559×732.7)	148
UCGT-05Ms40A20-AA UCGT-05Ms50A20-AA UCGT-15Ms40A20-AA UCGT-15Ms50A20-AA	UVH-05H40A20 UVH-05H50A20 UVH-15H40A20 UVH-15H50A20	31.65×22×28.85 (804×559×732.7)	149
UCGT-05Ms50C12-AA UCGT-15Ms50C12-AA	UVH-05H50C12 UVH-15H50C12	31.62×32×28.85 (804×813×732.7)	148
UCGT-05Ms40C20-AA UCGT-05Ms50C20-AA UCGT-15Ms40C20-AA UCGT-15Ms50C20-AA	UVH-05H40C20 UVH-05H50C20 UVH-15H40C20 UVH-15H50C20	31.62×32×28.85 (804×813×732.7)	149
UCGT-05Ms25C30-AA UCGT-05Ms32C30-AA UCGT-05Ms40C30-AA UCGT-05Ms50C30-AA UCGT-15Ms25C30-AA UCGT-15Ms32C30-AA UCGT-15Ms40C30-AA UCGT-15Ms50C30-AA	UVH-05H25C30 UVH-05H32C30 UVH-05H40C30 UVH-05H50C30 UVH-15H25C30 UVH-15H32C30 UVH-15H40C30 UVH-15H50C30	31.62×32×28.85 (804×813×732.7)	150
UCGT-05Ms25L40-AA UCGT-05Ms32L40-AA UCGT-05Ms40L40-AA UCGT-05Ms50L40-AA UCGT-15Ms25L40-AA UCGT-15Ms32L40-AA UCGT-15Ms40L40-AA UCGT-15Ms50L40-AA	UVH-05H25L40 UVH-05H32L40 UVH-05H40L40 UVH-05H50L40 UVH-15H25L40 UVH-15H32L40 UVH-15H40L40 UVH-15H50L40	39.45×41.06×28.61 (1002×1043×726.7)	150
UCGT-27Ms32C12-AA UCGT-27Ms40C12-AA	UVH-27H32C12 UVH-27H40C12	36.61×31.81×34.75 (930×808×882.6)	151
UCGT-27Ms32C20-AA UCGT-27Ms40C20-AA	UVH-27H32C20 UVH-27H40C20	36.61×31.81×34.75 (930×808×882.6)	151
UCGT-27Ms25C25-AA UCGT-27Ms32C25-AA UCGT-27Ms40C25-AA	UVH-27H25C25 UVH-27H32C25 UVH-27H40C25	36.61×31.81×34.75 (930×808×882.6)	152
UCGT-27Ms25C28-AA UCGT-27Ms32C28-AA UCGT-27Ms40C28-AA	UVH-27H25C28 UVH-27H32C28 UVH-27H40C28	36.61×31.81×34.75 (930×808×882.6)	152

Selection guide of ground and test devices

Selection table of ground and test devices

Upper terminals only

Type of GT	Related VCB	Outline dimension H×W×D [inch/(mm)]	Dimension page
UCGT-05Ms25A12-AB UCGT-05Ms32A12-AB UCGT-15Ms25A12-AB UCGT-15Ms32A12-AB	UVM-05H25A12 UVM-05H32A12 UVM-15H25A12 UVM-15H32A12	26.26×22×28.85 (677×559×732.7)	145
UCGT-05Ms25A20-AB UCGT-05Ms32A20-AB UCGT-15Ms25A20-AB UCGT-15Ms32A20-AB	UVM-05H25A20 UVM-05H32A20 UVM-15H25A20 UVM-15H32A20	26.26×22×28.85 (677×559×732.7)	146
UCGT-05Ms25C12-AB UCGT-05Ms32C12-AB UCGT-15Ms25C12-AB UCGT-15Ms32C12-AB	UVM-05H25C12 UVM-05H32C12 UVM-15H25C12 UVM-15H32C12	31.65×32×28.85 (677×813×732.7)	145
UCGT-05Ms25C20-AB UCGT-05Ms32C20-AB UCGT-15Ms25C20-AB UCGT-15Ms32C20-AB	UVM-05H25C20 UVM-05H32C20 UVM-15H25C20 UVM-15H32C20	31.62×32×28.85 (677×813×732.7)	146
UCGT-05Ms40A12-AB UCGT-15Ms40A12-AB	UVH-05H40A12 UVH-15H40A12	31.65×22×28.85 (804×559×732.7)	147
UCGT-15Ms40C12-AB UCGT-05Ms40C12-AB	UVH-05H40C12 UVH-15H40C12	31.62×32×28.85 (804×813×732.7)	147
UCGT-05Ms50A12-AB UCGT-15Ms50A12-AB	UVH-05H50A12 UVH-15H50A12	31.65×22×28.85 (804×559×732.7)	148
UCGT-05Ms40A20-AB UCGT-05Ms50A20-AB UCGT-15Ms40A20-AB UCGT-15Ms50A20-AB	UVH-05H40A20 UVH-05H50A20 UVH-15H40A20 UVH-15H50A20	31.65×22×28.85 (804×559×732.7)	149
UCGT-05Ms50C12-AB UCGT-15Ms50C12-AB	UVH-05H50C12 UVH-15H50C12	31.62×32×28.85 (804×813×732.7)	148
UCGT-05Ms40C20-AB UCGT-05Ms50C20-AB UCGT-15Ms40C20-AB UCGT-15Ms50C20-AB	UVH-05H40C20 UVH-05H50C20 UVH-15H40C20 UVH-15H50C20	31.62×32×28.85 (804×813×732.7)	149
UCGT-05Ms25C30-AB UCGT-05Ms32C30-AB UCGT-05Ms40C30-AB UCGT-05Ms50C30-AB UCGT-15Ms25C30-AB UCGT-15Ms32C30-AB UCGT-15Ms40C30-AB UCGT-15Ms50C30-AB	UVH-05H25C30 UVH-05H32C30 UVH-05H40C30 UVH-05H50C30 UVH-15H25C30 UVH-15H32C30 UVH-15H40C30 UVH-15H50C30	31.62×32×28.85 (804×813×732.7)	150
UCGT-05Ms25L40-AB UCGT-05Ms32L40-AB UCGT-05Ms40L40-AB UCGT-05Ms50L40-AB UCGT-15Ms25L40-AB UCGT-15Ms32L40-AB UCGT-15Ms40L40-AB UCGT-15Ms50L40-AB	UVH-05H25L40 UVH-05H32L40 UVH-05H40L40 UVH-05H50L40 UVH-15H25L40 UVH-15H32L40 UVH-15H40L40 UVH-15H50L40	39.45×41.06×28.61 (1002×1043×726.7)	150
UCGT-27Ms32C12-AB UCGT-27Ms40C12-AB	UVH-27H32C12 UVH-27H40C12	36.61×31.81×34.75 (930×808×882.6)	151
UCGT-27Ms32C20-AB UCGT-27Ms40C20-AB	UVH-27H32C20 UVH-27H40C20	36.61×31.81×34.75 (930×808×882.6)	151
UCGT-27Ms25C25-AB UCGT-27Ms32C25-AB UCGT-27Ms40C25-AB	UVH-27H25C25 UVH-27H32C25 UVH-27H40C25	36.61×31.81×34.75 (930×808×882.6)	152
UCGT-27Ms25C28-AB UCGT-27Ms32C28-AB UCGT-27Ms40C28-AB	UVH-27H25C28 UVH-27H32C28 UVH-27H40C28	36.61×31.81×34.75 (930×808×882.6)	152

Selection table of ground and test devices

Lower terminals only

Type of GT	Related VCB	Outline dimension H×W×D [inch/(mm)]	Dimension page
UCGT-05Ms25A12-AC UCGT-05Ms32A12-AC UCGT-15Ms25A12-AC UCGT-15Ms32A12-AC	UVM-05H25A12 UVM-05H32A12 UVM-15H25A12 UVM-15H32A12	26.26×22×28.85 (677×559×732.7)	145
UCGT-05Ms25A20-AC UCGT-05Ms32A20-AC UCGT-15Ms25A20-AC UCGT-15Ms32A20-AC	UVM-05H25A20 UVM-05H32A20 UVM-15H25A20 UVM-15H32A20	26.26×22×28.85 (677×559×732.7)	146
UCGT-05Ms25C12-AC UCGT-05Ms32C12-AC UCGT-15Ms25C12-AC UCGT-15Ms32C12-AC	UVM-05H25C12 UVM-05H32C12 UVM-15H25C12 UVM-15H32C12	31.65×32×28.85 (677×813×732.7)	145
UCGT-05Ms25C20-AC UCGT-05Ms32C20-AC UCGT-15Ms25C20-AC UCGT-15Ms32C20-AC	UVM-05H25C20 UVM-05H32C20 UVM-15H25C20 UVM-15H32C20	31.62×32×28.85 (677×813×732.7)	146
UCGT-05Ms40A12-AC UCGT-15Ms40A12-AC	UVH-05H40A12 UVH-15H40A12	31.65×22×28.85 (804×559×732.7)	147
UCGT-15Ms40C12-AC UCGT-05Ms40C12-AC	UVH-05H40C12 UVH-15H40C12	31.62×32×28.85 (804×813×732.7)	147
UCGT-05Ms50A12-AC UCGT-15Ms50A12-AC	UVH-05H50A12 UVH-15H50A12	31.65×22×28.85 (804×559×732.7)	148
UCGT-05Ms40A20-AC UCGT-05Ms50A20-AC UCGT-15Ms40A20-AC UCGT-15Ms50A20-AC	UVH-05H40A20 UVH-05H50A20 UVH-15H40A20 UVH-15H50A20	31.65×22×28.85 (804×559×732.7)	149
UCGT-05Ms50C12-AC UCGT-15Ms50C12-AC	UVH-05H50C12 UVH-15H50C12	31.62×32×28.85 (804×813×732.7)	148
UCGT-05Ms40C20-AC UCGT-05Ms50C20-AC UCGT-15Ms40C20-AC UCGT-15Ms50C20-AC	UVH-05H40C20 UVH-05H50C20 UVH-15H40C20 UVH-15H50C20	31.62×32×28.85 (804×813×732.7)	149
UCGT-05Ms25C30-AC UCGT-05Ms32C30-AC UCGT-05Ms40C30-AC UCGT-05Ms50C30-AC UCGT-15Ms25C30-AC UCGT-15Ms32C30-AC UCGT-15Ms40C30-AC UCGT-15Ms50C30-AC	UVH-05H25C30 UVH-05H32C30 UVH-05H40C30 UVH-05H50C30 UVH-15H25C30 UVH-15H32C30 UVH-15H40C30 UVH-15H50C30	31.62×32×28.85 (804×813×732.7)	150
UCGT-05Ms25L40-AC UCGT-05Ms32L40-AC UCGT-05Ms40L40-AC UCGT-05Ms50L40-AC UCGT-15Ms25L40-AC UCGT-15Ms32L40-AC UCGT-15Ms40L40-AC UCGT-15Ms50L40-AC	UVH-05H25L40 UVH-05H32L40 UVH-05H40L40 UVH-05H50L40 UVH-15H25L40 UVH-15H32L40 UVH-15H40L40 UVH-15H50L40	39.45×41.06×28.61 (1002×1043×726.7)	150
UCGT-27Ms32C12-AC UCGT-27Ms40C12-AC	UVH-27H32C12 UVH-27H40C12	36.61×31.81×34.75 (930×808×882.6)	151
UCGT-27Ms32C20-AC UCGT-27Ms40C20-AC	UVH-27H32C20 UVH-27H40C20	36.61×31.81×34.75 (930×808×882.6)	151
UCGT-27Ms25C25-AC UCGT-27Ms32C25-AC UCGT-27Ms40C25-AC	UVH-27H25C25 UVH-27H32C25 UVH-27H40C25	36.61×31.81×34.75 (930×808×882.6)	152
UCGT-27Ms25C28-AC UCGT-27Ms32C28-AC UCGT-27Ms40C28-AC	UVH-27H25C28 UVH-27H32C28 UVH-27H40C28	36.61×31.81×34.75 (930×808×882.6)	152

Selection guide of ground and test devices

Selection table of ground and test devices

Upper and lower terminals with auxiliary wheels

Type of GT	Related VCB	Outline dimension H×W×D [inch/(mm)]	Dimension page
UCGT-05Ms25A12-ABS UCGT-05Ms32A12-ABS UCGT-15Ms25A12-ABS UCGT-15Ms32A12-ABS	UVM-05H25A12 UVM-05H32A12 UVM-15H25A12 UVM-15H32A12	30.41×22×28.85 (772.5×559×732.7)	145
UCGT-05Ms25A20-ABS UCGT-05Ms32A20-ABS UCGT-15Ms25A20-ABS UCGT-15Ms32A20-ABS	UVM-05H25A20 UVM-05H32A20 UVM-15H25A20 UVM-15H32A20	30.41×22×28.85 (772.5×559×732.7)	146
UCGT-05Ms25C12-ABS UCGT-05Ms32C12-ABS UCGT-15Ms25C12-ABS UCGT-15Ms32C12-ABS	UVM-05H25C12 UVM-05H32C12 UVM-15H25C12 UVM-15H32C12	30.41×32×28.85 (772.5×813×732.7)	145
UCGT-05Ms25C20-ABS UCGT-05Ms32C20-ABS UCGT-15Ms25C20-ABS UCGT-15Ms32C20-ABS	UVM-05H25C20 UVM-05H32C20 UVM-15H25C20 UVM-15H32C20	30.41×32×28.85 (772.5×813×732.7)	146
UCGT-05Ms40A12-ABS UCGT-15Ms40A12-ABS	UVH-05H40A12 UVH-15H40A12	30.41×22×28.85 (772.5×559×732.7)	147
UCGT-15Ms40C12-ABS UCGT-05Ms40C12-ABS	UVH-05H40C12 UVH-15H40C12	35.41×32×28.85 (899.5×813×732.7)	147
UCGT-05Ms50A12-ABS UCGT-15Ms50A12-ABS	UVH-05H50A12 UVH-15H50A12	35.41×32×28.85 (899.5×813×732.7)	148
UCGT-05Ms40A20-ABS UCGT-05Ms50A20-ABS UCGT-15Ms40A20-ABS UCGT-15Ms50A20-ABS	UVH-05H40A20 UVH-05H50A20 UVH-15H40A20 UVH-15H50A20	30.41×22×28.85 (772.5×559×732.7)	149
UCGT-05Ms50C12-ABS UCGT-15Ms50C12-ABS	UVH-05H50C12 UVH-15H50C12	35.41×32×28.85 (899.5×813×732.7)	148
UCGT-05Ms40C20-ABS UCGT-05Ms50C20-ABS UCGT-15Ms40C20-ABS UCGT-15Ms50C20-ABS	UVH-05H40C20 UVH-05H50C20 UVH-15H40C20 UVH-15H50C20	35.41×32×28.85 (899.5×813×732.7)	149
UCGT-05Ms25C30-ABS UCGT-05Ms32C30-ABS UCGT-05Ms40C30-ABS UCGT-05Ms50C30-ABS UCGT-15Ms25C30-ABS UCGT-15Ms32C30-ABS UCGT-15Ms40C30-ABS UCGT-15Ms50C30-ABS	UVH-05H25C30 UVH-05H32C30 UVH-05H40C30 UVH-05H50C30 UVH-15H25C30 UVH-15H32C30 UVH-15H40C30 UVH-15H50C30	35.41×32×28.85 (899.5×813×732.7)	150
UCGT-05Ms25L40-ABS UCGT-05Ms32L40-ABS UCGT-05Ms40L40-ABS UCGT-05Ms50L40-ABS UCGT-15Ms25L40-ABS UCGT-15Ms32L40-ABS UCGT-15Ms40L40-ABS UCGT-15Ms50L40-ABS	UVH-05H25L40 UVH-05H32L40 UVH-05H40L40 UVH-05H50L40 UVH-15H25L40 UVH-15H32L40 UVH-15H40L40 UVH-15H50L40	43.38×41.06×28.61 (1101.8×1043×726.7)	150
UCGT-27Ms32C12-ABS UCGT-27Ms40C12-ABS	UVH-27H32C12 UVH-27H40C12	40.37×31.81×34.75 (1025.5×808×882.6)	151
UCGT-27Ms32C20-ABS UCGT-27Ms40C20-ABS	UVH-27H32C20 UVH-27H40C20	40.37×31.81×34.75 (1025.5×808×882.6)	151
UCGT-27Ms25C25-ABS UCGT-27Ms32C25-ABS UCGT-27Ms40C25-ABS	UVH-27H25C25 UVH-27H32C25 UVH-27H40C25	40.37×31.81×34.75 (1025.5×808×882.6)	152
UCGT-27Ms25C28-ABS UCGT-27Ms32C28-ABS UCGT-27Ms40C28-ABS	UVH-27H25C28 UVH-27H32C28 UVH-27H40C28	40.37×31.81×34.75 (1025.5×808×882.6)	152

Selection table of ground and test devices

Upper terminals only with auxiliary wheels

Type of GT	Related VCB	Outline dimension H×W×D [inch/(mm)]	Dimension page
UCGT-05Ms25A12-AAS UCGT-05Ms32A12-AAS UCGT-15Ms25A12-AAS UCGT-15Ms32A12-AAS	UVM-05H25A12 UVM-05H32A12 UVM-15H25A12 UVM-15H32A12	30.41×22×28.85 (772.5×559×732.7)	145
UCGT-05Ms25A20-AAS UCGT-05Ms32A20-AAS UCGT-15Ms25A20-AAS UCGT-15Ms32A20-AAS	UVM-05H25A20 UVM-05H32A20 UVM-15H25A20 UVM-15H32A20	30.41×22×28.85 (772.5×559×732.7)	146
UCGT-05Ms25C12-AAS UCGT-05Ms32C12-AAS UCGT-15Ms25C12-AAS UCGT-15Ms32C12-AAS	UVM-05H25C12 UVM-05H32C12 UVM-15H25C12 UVM-15H32C12	30.41×32×28.85 (772.5×813×732.7)	145
UCGT-05Ms25C20-AAS UCGT-05Ms32C20-AAS UCGT-15Ms25C20-AAS UCGT-15Ms32C20-AAS	UVM-05H25C20 UVM-05H32C20 UVM-15H25C20 UVM-15H32C20	30.41×32×28.85 (772.5×813×732.7)	146
UCGT-05Ms40A12-AAS UCGT-15Ms40A12-AAS	UVH-05H40A12 UVH-15H40A12	30.41×22×28.85 (772.5×559×732.7)	147
UCGT-15Ms40C12-AAS UCGT-05Ms40C12-AAS	UVH-05H40C12 UVH-15H40C12	35.41×32×28.85 (899.5×813×732.7)	147
UCGT-05Ms50A12-AAS UCGT-15Ms50A12-AAS	UVH-05H50A12 UVH-15H50A12	35.41×32×28.85 (899.5×813×732.7)	148
UCGT-05Ms40A20-AAS UCGT-05Ms50A20-AAS UCGT-15Ms40A20-AAS UCGT-15Ms50A20-AAS	UVH-05H40A20 UVH-05H50A20 UVH-15H40A20 UVH-15H50A20	30.41×22×28.85 (772.5×559×732.7)	149
UCGT-05Ms50C12-AAS UCGT-15Ms50C12-AAS	UVH-05H50C12 UVH-15H50C12	35.41×32×28.85 (899.5×813×732.7)	148
UCGT-05Ms40C20-AAS UCGT-05Ms50C20-AAS UCGT-15Ms40C20-AAS UCGT-15Ms50C20-AAS	UVH-05H40C20 UVH-05H50C20 UVH-15H40C20 UVH-15H50C20	35.41×32×28.85 (899.5×813×732.7)	149
UCGT-05Ms25C30-AAS UCGT-05Ms32C30-AAS UCGT-05Ms40C30-AAS UCGT-05Ms50C30-AAS UCGT-15Ms25C30-AAS UCGT-15Ms32C30-AAS UCGT-15Ms40C30-AAS UCGT-15Ms50C30-AAS	UVH-05H25C30 UVH-05H32C30 UVH-05H40C30 UVH-05H50C30 UVH-15H25C30 UVH-15H32C30 UVH-15H40C30 UVH-15H50C30	35.41×32×28.85 (899.5×813×732.7)	150
UCGT-05Ms25L40-AAS UCGT-05Ms32L40-AAS UCGT-05Ms40L40-AAS UCGT-05Ms50L40-AAS UCGT-15Ms25L40-AAS UCGT-15Ms32L40-AAS UCGT-15Ms40L40-AAS UCGT-15Ms50L40-AAS	UVH-05H25L40 UVH-05H32L40 UVH-05H40L40 UVH-05H50L40 UVH-15H25L40 UVH-15H32L40 UVH-15H40L40 UVH-15H50L40	43.38×41.06×28.61 (1101.8×1043×726.7)	150
UCGT-27Ms32C12-AAS UCGT-27Ms40C12-AAS	UVH-27H32C12 UVH-27H40C12	40.37×31.81×34.75 (1025.5×808×882.6)	151
UCGT-27Ms32C20-AAS UCGT-27Ms40C20-AAS	UVH-27H32C20 UVH-27H40C20	40.37×31.81×34.75 (1025.5×808×882.6)	151
UCGT-27Ms25C25-AAS UCGT-27Ms32C25-AAS UCGT-27Ms40C25-AAS	UVH-27H25C25 UVH-27H32C25 UVH-27H40C25	40.37×31.81×34.75 (1025.5×808×882.6)	152
UCGT-27Ms25C28-AAS UCGT-27Ms32C28-AAS UCGT-27Ms40C28-AAS	UVH-27H25C28 UVH-27H32C28 UVH-27H40C28	40.37×31.81×34.75 (1025.5×808×882.6)	152

Selection guide of ground and test devices

Selection table of ground and test devices

Lower terminals only with auxiliary wheels

Type of GT	Related VCB	Outline dimension H×W×D [inch/(mm)]	Dimension page
UCGT-05Ms25A12-ACS UCGT-05Ms32A12-ACS UCGT-15Ms25A12-ACS UCGT-15Ms32A12-ACS	UVM-05H25A12 UVM-05H32A12 UVM-15H25A12 UVM-15H32A12	30.41×22×28.85 (772.5×559×732.7)	145
UCGT-05Ms25A20-ACS UCGT-05Ms32A20-ACS UCGT-15Ms25A20-ACS UCGT-15Ms32A20-ACS	UVM-05H25A20 UVM-05H32A20 UVM-15H25A20 UVM-15H32A20	30.41×22×28.85 (772.5×559×732.7)	146
UCGT-05Ms25C12-ACS UCGT-05Ms32C12-ACS UCGT-15Ms25C12-ACS UCGT-15Ms32C12-ACS	UVM-05H25C12 UVM-05H32C12 UVM-15H25C12 UVM-15H32C12	30.41×32×28.85 (772.5×813×732.7)	145
UCGT-05Ms25C20-ACS UCGT-05Ms32C20-ACS UCGT-15Ms25C20-ACS UCGT-15Ms32C20-ACS	UVM-05H25C20 UVM-05H32C20 UVM-15H25C20 UVM-15H32C20	30.41×32×28.85 (772.5×813×732.7)	146
UCGT-05Ms40A12-ACS UCGT-15Ms40A12-ACS	UVH-05H40A12 UVH-15H40A12	30.41×22×28.85 (772.5×559×732.7)	147
UCGT-15Ms40C12-ACS UCGT-05Ms40C12-ACS	UVH-05H40C12 UVH-15H40C12	35.41×32×28.85 (899.5×813×732.7)	147
UCGT-05Ms50A12-ACS UCGT-15Ms50A12-ACS	UVH-05H50A12 UVH-15H50A12	35.41×32×28.85 (899.5×813×732.7)	148
UCGT-05Ms40A20-ACS UCGT-05Ms50A20-ACS UCGT-15Ms40A20-ACS UCGT-15Ms50A20-ACS	UVH-05H40A20 UVH-05H50A20 UVH-15H40A20 UVH-15H50A20	30.41×22×28.85 (772.5×559×732.7)	149
UCGT-05Ms50C12-ACS UCGT-15Ms50C12-ACS	UVH-05H50C12 UVH-15H50C12	35.41×32×28.85 (899.5×813×732.7)	148
UCGT-05Ms40C20-ACS UCGT-05Ms50C20-ACS UCGT-15Ms40C20-ACS UCGT-15Ms50C20-ACS	UVH-05H40C20 UVH-05H50C20 UVH-15H40C20 UVH-15H50C20	35.41×32×28.85 (899.5×813×732.7)	149
UCGT-05Ms25C30-ACS UCGT-05Ms32C30-ACS UCGT-05Ms40C30-ACS UCGT-05Ms50C30-ACS UCGT-15Ms25C30-ACS UCGT-15Ms32C30-ACS UCGT-15Ms40C30-ACS UCGT-15Ms50C30-ACS	UVH-05H25C30 UVH-05H32C30 UVH-05H40C30 UVH-05H50C30 UVH-15H25C30 UVH-15H32C30 UVH-15H40C30 UVH-15H50C30	35.41×32×28.85 (899.5×813×732.7)	150
UCGT-05Ms25L40-ACS UCGT-05Ms32L40-ACS UCGT-05Ms40L40-ACS UCGT-05Ms50L40-ACS UCGT-15Ms25L40-ACS UCGT-15Ms32L40-ACS UCGT-15Ms40L40-ACS UCGT-15Ms50L40-ACS	UVH-05H25L40 UVH-05H32L40 UVH-05H40L40 UVH-05H50L40 UVH-15H25L40 UVH-15H32L40 UVH-15H40L40 UVH-15H50L40	43.38×41.06×28.61 (1101.8×1043×726.7)	150
UCGT-27Ms32C12-ACS UCGT-27Ms40C12-ACS	UVH-27H32C12 UVH-27H40C12	40.37×31.81×34.75 (1025.5×808×882.6)	151
UCGT-27Ms32C20-ACS UCGT-27Ms40C20-ACS	UVH-27H32C20 UVH-27H40C20	40.37×31.81×34.75 (1025.5×808×882.6)	151
UCGT-27Ms25C25-ACS UCGT-27Ms32C25-ACS UCGT-27Ms40C25-ACS	UVH-27H25C25 UVH-27H32C25 UVH-27H40C25	40.37×31.81×34.75 (1025.5×808×882.6)	152
UCGT-27Ms25C28-ACS UCGT-27Ms32C28-ACS UCGT-27Ms40C28-ACS	UVH-27H25C28 UVH-27H32C28 UVH-27H40C28	40.37×31.81×34.75 (1025.5×808×882.6)	152

4.76/15kV, 25/31.5kA, 1200A

UCGT type, Drawout type

Type of ground and test device

- UCGT-05Ms25A12
- UCGT-05Ms32A12
- UCGT-15Ms25A12
- UCGT-15Ms32A12

Related VCB

- VVM-05H25A12
- VVM-05H32A12
- VVM-15H25A12
- VVM-15H32A12

[Unit: inch(mm)]

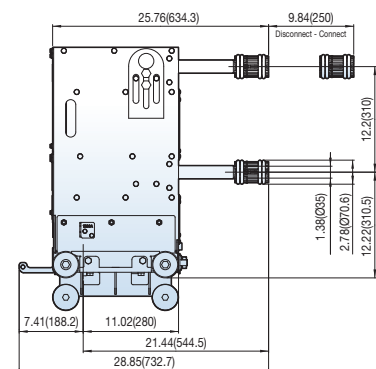
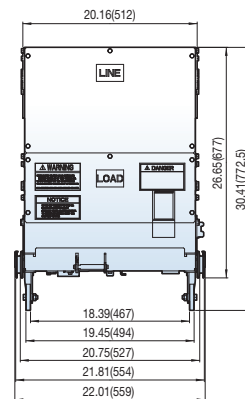
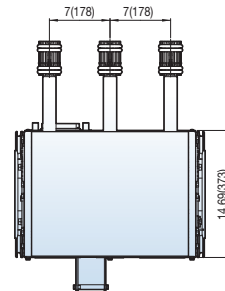

Type of ground and test device

- UCGT-05Ms25C12
- UCGT-05Ms32C12
- UCGT-15Ms25C12
- UCGT-15Ms32C12

Related VCB

- VVM-05H25C12
- VVM-05H32C12
- VVM-15H25C12
- VVM-15H32C12

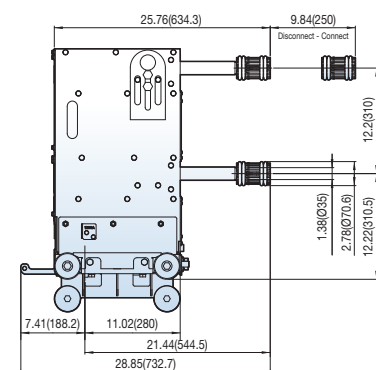
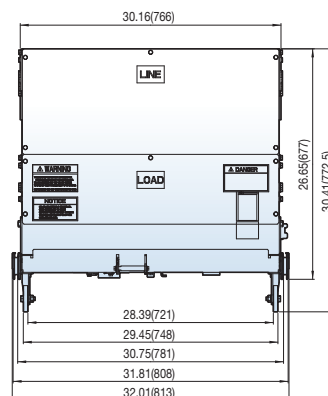
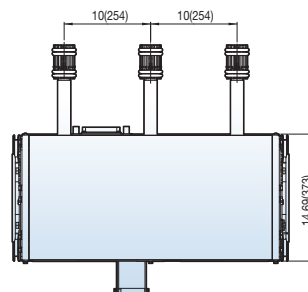

Dimensions

4.76/15kV, 25/31.5kA, 2000A

UCGT type, Drawout type

Type of ground and test device

- UCGT-05Ms25A20
- UCGT-05Ms32A20
- UCGT-15Ms25A20
- UCGT-15Ms32A20

Related VCB

- UVM-05H25A20
- UVM-05H32A20
- UVM-15H25A20
- UVM-15H32A20

[Unit: inch(mm)]

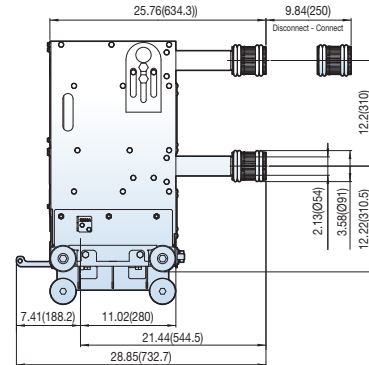
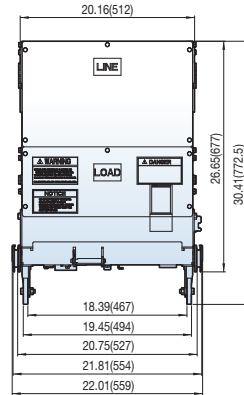
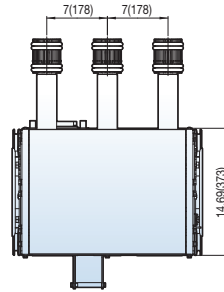

Type of ground and test device

- UCGT-05Ms25C20
- UCGT-05Ms32C20
- UCGT-15Ms25C20
- UCGT-15Ms32C20

Related VCB

- UVM-05H25C20
- UVM-05H32C20
- UVM-15H25C20
- UVM-15H32C20

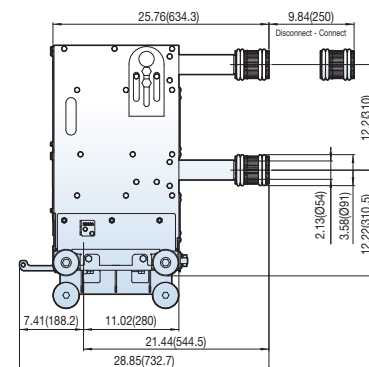
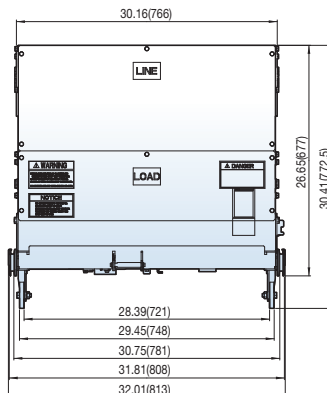
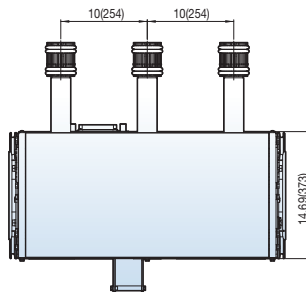

4.76/15kV, 40kA, 1200A

UCGT type, Drawout type

Type of ground and test device

UCGT-05Ms40A12
UCGT-15Ms40A12

Related VCB

UVH-05H40A12
UVH-15H40A12

[Unit: inch(mm)]

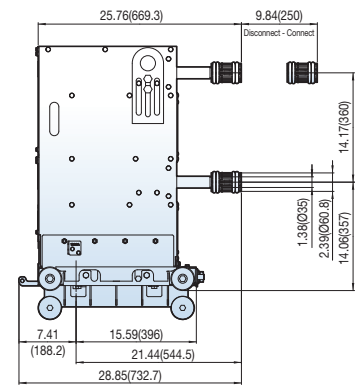
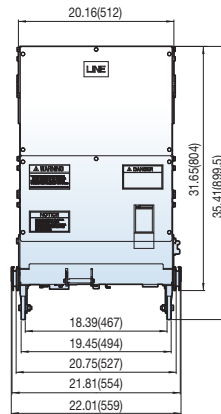
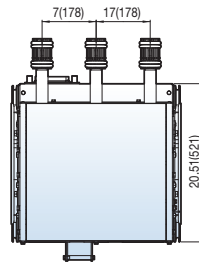

Type of ground and test device

UCGT-05Ms40C12
UCGT-15Ms40C12

Related VCB

UVH-05H40C12
UVH-15H40C12

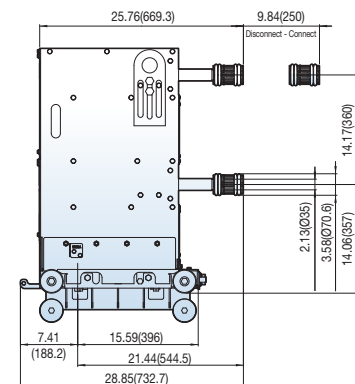
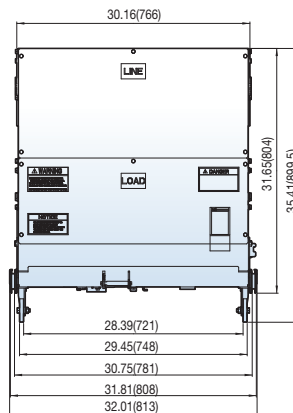
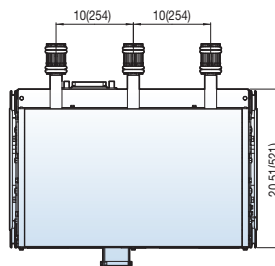

Dimensions

4.76/15kV, 50kA, 1200A

UCGT type, Drawout type

Type of ground and test device

UCGT-05Ms50A12
UCGT-15Ms50A12

Related VCB

UVH-05H50A12
UVH-15H50A12

[Unit: inch(mm)]

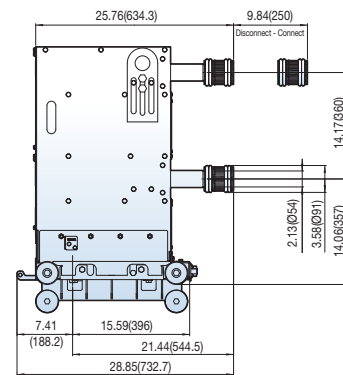
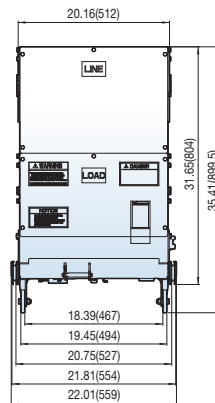
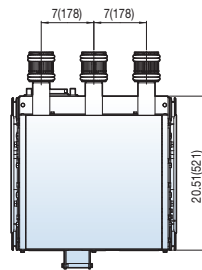

Type of ground and test device

UCGT-05Ms50C12
UCGT-15Ms50C12

Related VCB

UVH-05H50C12
UVH-15H50C12

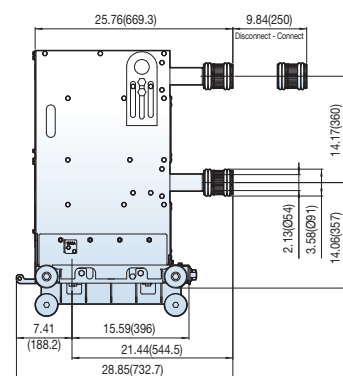
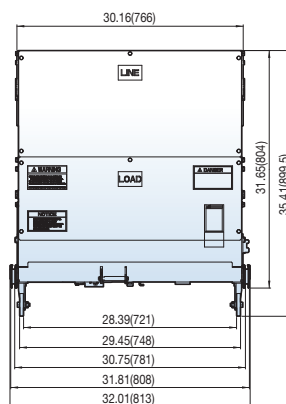
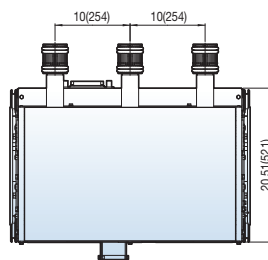

4.76/15kV, 40/50kA, 2000A

UCGT type, Drawout type

Type of ground and test device

- UCGT-05Ms40A20
- UCGT-05Ms50A20
- UCGT-15Ms40A20
- UCGT-15Ms50A20

Related VCB

- UVH-05H40A20
- UVH-05H50A20
- UVH-15H40A20
- UVH-15H50A20

[Unit: inch(mm)]

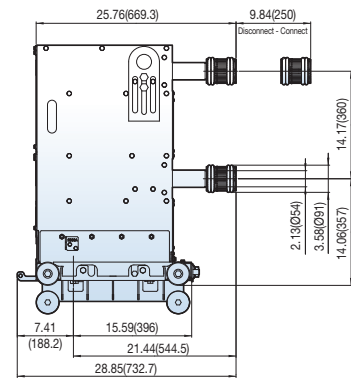
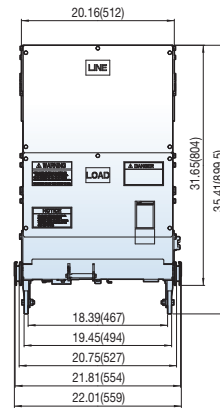
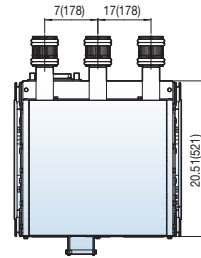

Type of ground and test device

- UCGT-05Ms40C20
- UCGT-05Ms50C20
- UCGT-15Ms40C20
- UCGT-15Ms50C20

Related VCB

- UVH-05H40C20
- UVH-05H50C20
- UVH-15H40C20
- UVH-15H50C20

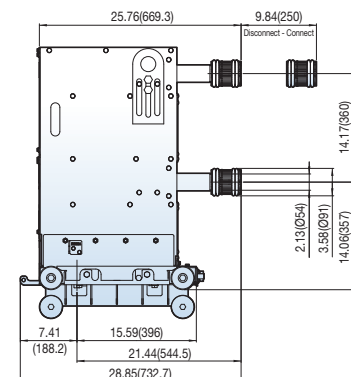
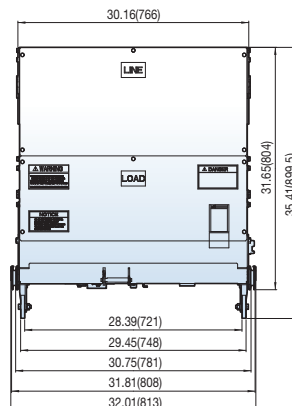
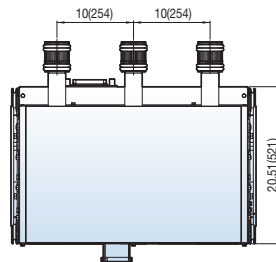

Dimensions

4.76/15kV, 25/31.5/40/50kA, 3000A

UCGT type, Drawout type

Type of ground and test device

UCGT-05Ms25C30
 UCGT-05Ms32C30
 UCGT-05Ms40C30
 UCGT-05Ms50C30
 UCGT-15Ms25C30
 UCGT-15Ms32C30
 UCGT-15Ms40C30
 UCGT-15Ms50C30

Related VCB

UVH-05H25C30
 UVH-05H32C30
 UVH-05H40C30
 UVH-05H50C30
 UVH-15H25C30
 UVH-15H32C30
 UVH-15H40C30
 UVH-15H50C30

[Unit: inch(mm)]

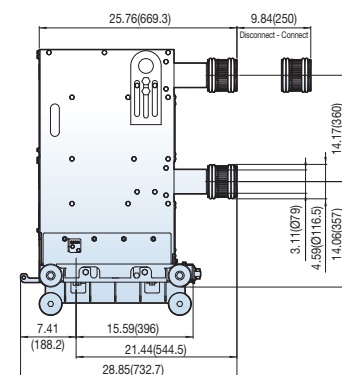
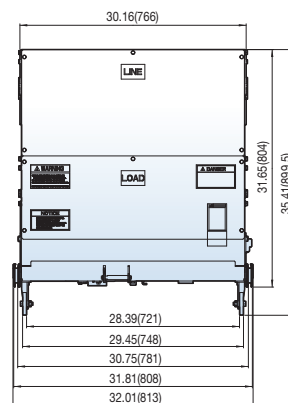
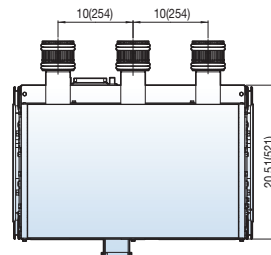

4.76/15kV, 25/31.5/40/50kA, 4000A

Type of ground and test device

UCGT-05Ms25L40
 UCGT-05Ms32L40
 UCGT-05Ms40L40
 UCGT-05Ms50L40
 UCGT-15Ms25L40
 UCGT-15Ms32L40
 UCGT-15Ms40L40
 UCGT-15Ms50L40

Related VCB

UVH-05H25C40
 UVH-05H32C40
 UVH-05H40C40
 UVH-05H50C40
 UVH-15H25C40
 UVH-15H32C40
 UVH-15H40C40
 UVH-15H50C40

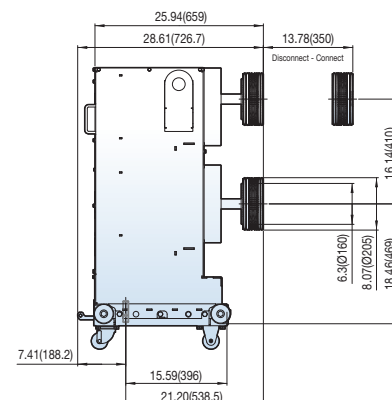
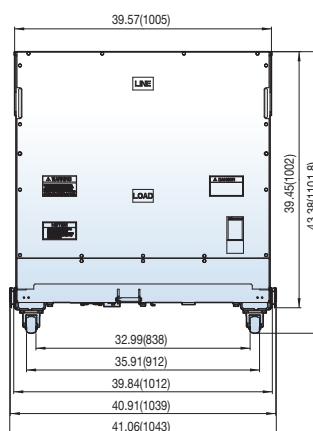
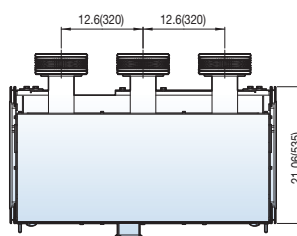

27kV, 31.5/40kA, 1200A

UCGT type, Drawout type

Type of ground and test device

UCGT-27Ms32C12
UCGT-27Ms40C12

Related VCB

UVH-27H32C12
UVH-27H40C12

[Unit: inch(mm)]

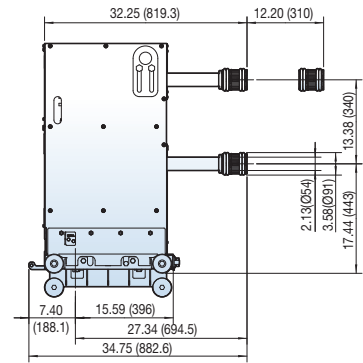
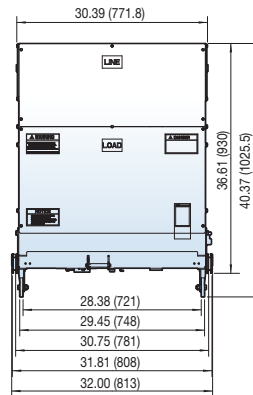
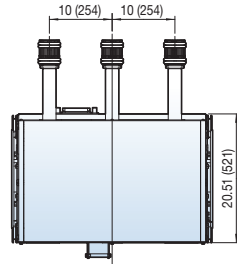

27kV, 31.5/40kA, 2000A

Type of ground and test device

UCGT-27Ms32C20
UCGT-27Ms40C20

Related VCB

UVH-27H32C20
UVH-27H40C20

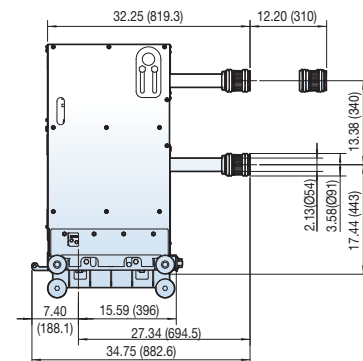
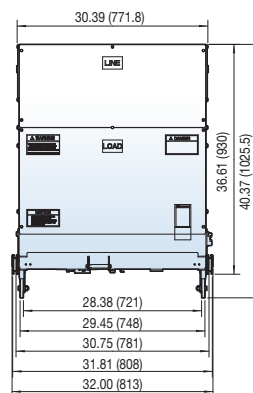
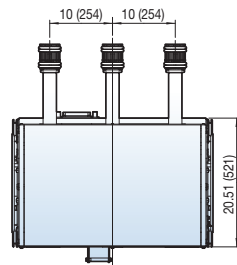

Dimensions

27kV, 25/31.5/40kA, 2500A

UCGT type, Drawout type

Type of ground and test device

UCGT-27Ms25C25
UCGT-27Ms32C25
UCGT-27Ms40C25

Related VCB

UVH-27H25C25
UVH-27H32C25
UVH-27H40C25

[Unit: inch(mm)]

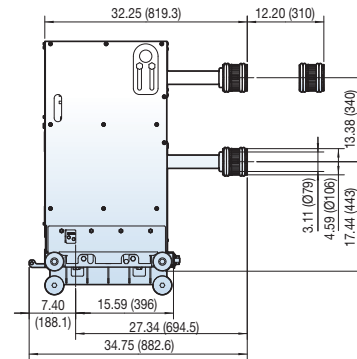
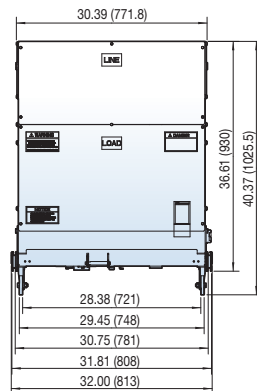
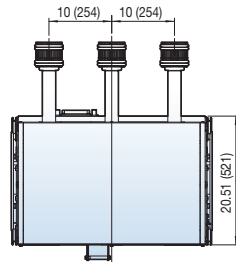

27kV, 25/31.5/40kA, 2750A

Type of ground and test device

UCGT-27Ms25C28
UCGT-27Ms32C28
UCGT-27Ms40C28

Related VCB

UVH-27H25C28
UVH-27H32C28
UVH-27H40C28

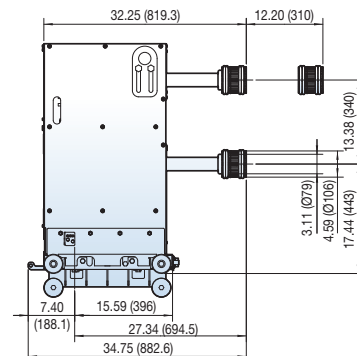
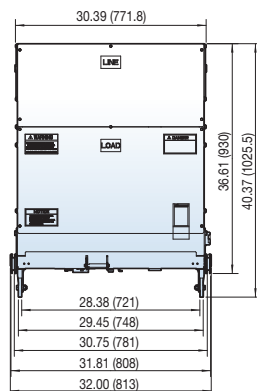
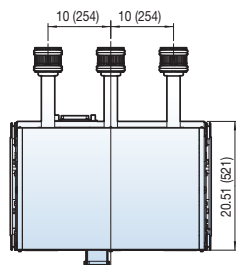

Susol VCB



Contents

▪ Accessory	154
▪ Control circuit diagram	186
▪ Technical data	192

Accessories

Motor: M1~M8

UVL/UVM type

- Charges the closing spring of a circuit breaker by the external power source. When the charging is complete, the control power of the motor will be turned "OFF" by the built-in Limit S/W. Without the external power source, charge manually.

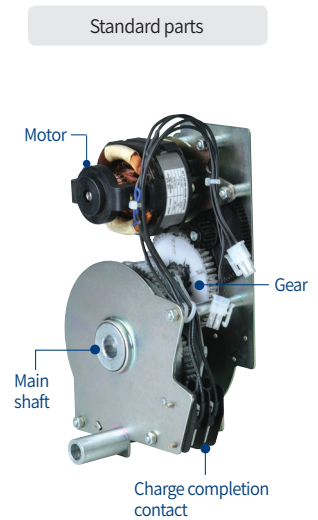
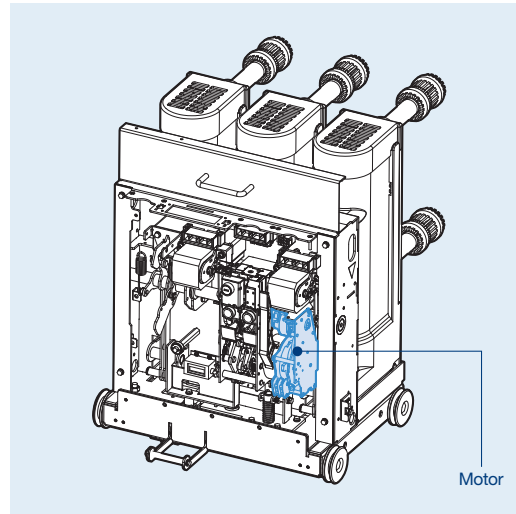

Input voltage (Vn)	UVL/UVM type							
	DC 110V	DC 200V~250V	DC 125V	DC 24V~30V	DC 48V~60V	AC 48V	AC 100V~130V	AC 200V~250V
Load current (A)	≤ 1	≤ 0.5	≤ 1	≤ 5	≤ 3	≤ 3	≤ 1	≤ 0.5
Starting current (A)	5 times of load current							
Charge time	Within 5 seconds at the rated control voltage							

Note) Rated operation and control voltage range, see page 158.

UVH type

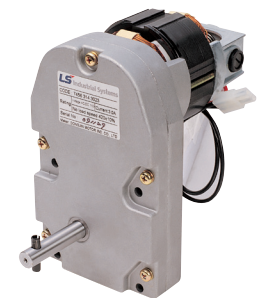
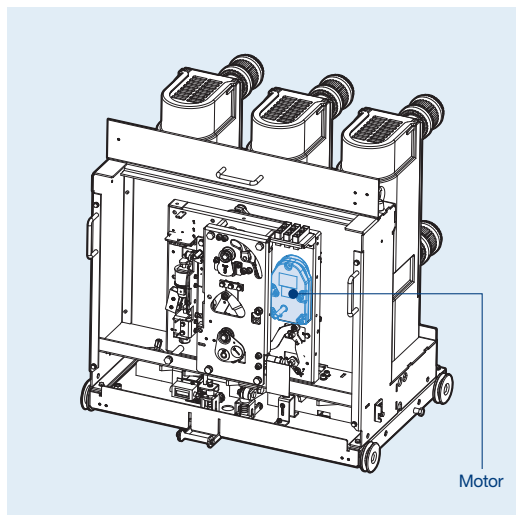

Input voltage (Vn)	UVH type						
	DC 110V	DC 200~250V	DC 125V	DC 48~60V	AC 48V	AC 100~130V	AC 200~250V
Load current (A)	≤ 3	≤ 2.6	≤ 3	≤ 6	≤ 6	≤ 3	≤ 2.6
Starting current (A)	≤ 20	≤ 17	≤ 20	≤ 30	≤ 30	≤ 20	≤ 17
Charge time	Within 12 seconds at the rated control voltage						

Note) Rated operation and control voltage range, see page 158.

Closing Coil: C1~C8

Standard parts

UVL/UVM type

- A control device that closes a circuit breaker when a voltage is applied to the coil control terminals continuously or instantaneously for over 200ms.

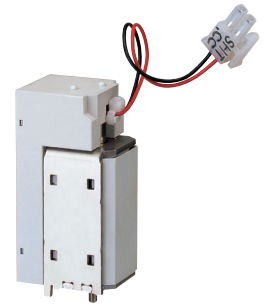
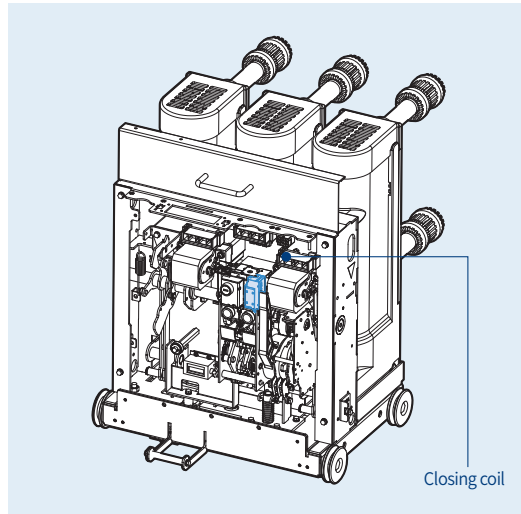

Input voltage (Vn)	UVL/UVM type							
	DC 110V	DC 200V~250V	DC 125V	DC 24V~30V	DC 48V~60V	AC 48V	AC 100V~130V	AC 200V~250V
Power consumption (inrush, VA)	-	-	-	-	-	-	200	
Power consumption (steady, VA)	-	-	-	-	-	-	≤ 5	
Rated current (A)	≤ 4	≤ 2	≤ 4	≤ 10	≤ 5	-	-	

Note) Rated operation and control voltage range, see page 158.

UVH type

- A control device that closes a circuit breaker when a voltage is applied to the coil control terminals continuously for over 45ms.

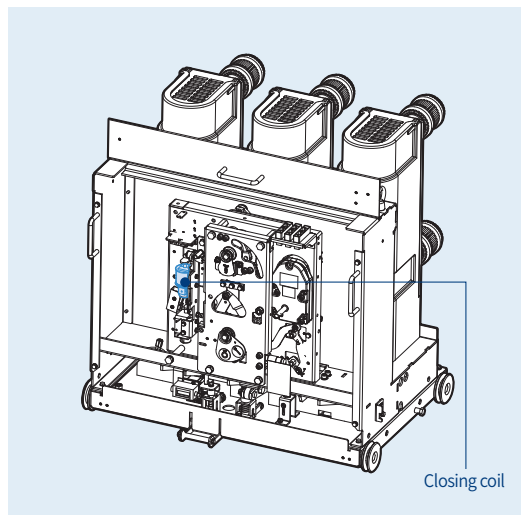

Input voltage (Vn)	UVH type						
	DC 110V	DC 200~250V	DC 125V	DC 48~60V	AC 48V	AC 100~130V	AC 200~250V
Rated current (A)	≤ 3.5	≤ 2.5	≤ 3.5	≤ 8	≤ 8	≤ 3.5	≤ 2.5

Note) Rated operation and control voltage range, see page 158.

Accessories

Trip Coil: T1~T8

UVL/UVM type

- A control device that remotely trips a circuit breaker when a voltage is applied to the coil control terminals continuously or instantaneously for over 35ms.
- When UVT coil is installed, its location is changed.

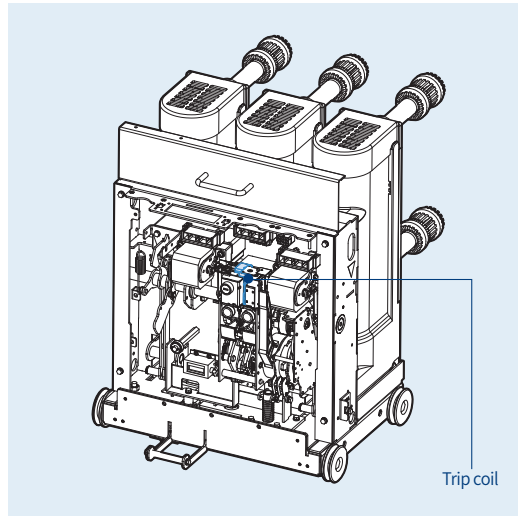

Standard parts

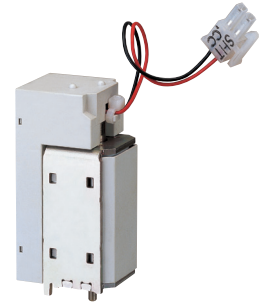

Input voltage (Vn)	UVL/UVM type							
	DC 110V	DC 200V~250V	DC 125V	DC 24V~30V	DC 48V~60V	AC 48V	AC 100V~130V	AC 200V~250V
Power consumption (inrush, VA)							200	
Power consumption (steady, VA)			-				≤ 5	
Rated current (A)	≤ 4	≤ 2	≤ 4	≤ 10	≤ 5		-	

Note) Rated operation and control voltage range, see page 158.

UVH type

- A control device that remotely trips a circuit breaker when a voltage is applied to the coil control terminals continuously or instantaneously for over 35ms.

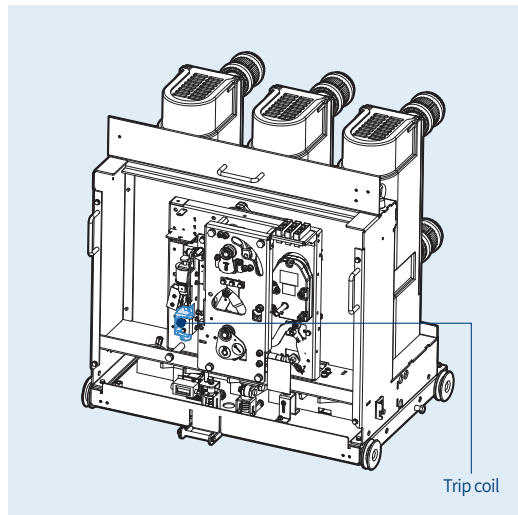

Input voltage (Vn)	UVH type						
	DC 110V	DC 200~250V	DC 125V	DC 48~60V	AC 48V	AC 100~130V	AC 200~250V
Rated current (A)	≤ 3.5	≤ 2.5	≤ 3.5	≤ 8	≤ 8	≤ 3.5	≤ 2.5

Note) Rated operation and control voltage range, see page 158.

Secondary Trip Coil: A1

UVL/UVM type

- A control device that trips a circuit breaker in case the first trip coil (T) fails to operate (backup trip coil)
- Secondary trip coil: Install on the right side of the trip coil.
- Secondary trip coil is not available when UVT coil is installed.

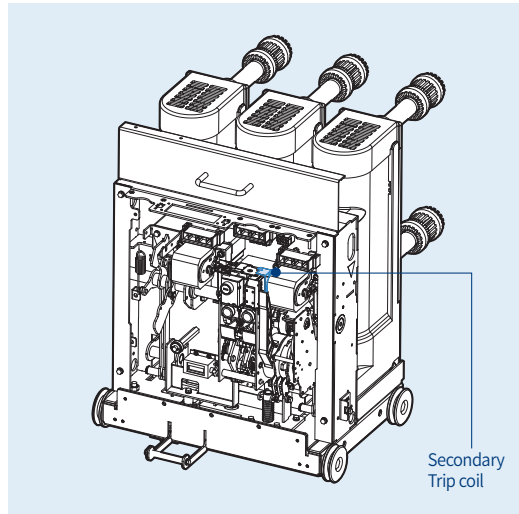

Breaker Options

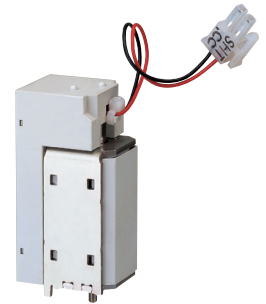

Input voltage (Vn)	UVL/UVM type							
	DC 110V	DC 200V~250V	DC 125V	DC 24V~30V	DC 48V~60V	AC 48V	AC 100V~130V	AC 200V~250V
Power consumption (inrush, VA)							200	
Power consumption (steady, VA)							≤ 5	
Rated current (A)	≤ 4	≤ 2	≤ 4	≤ 10	≤ 5			

UVH type

- A control device that trips a circuit breaker in case the first trip coil (T) fails to operate (backup trip coil)
- Secondary trip coil is not available when UVT coil is installed.

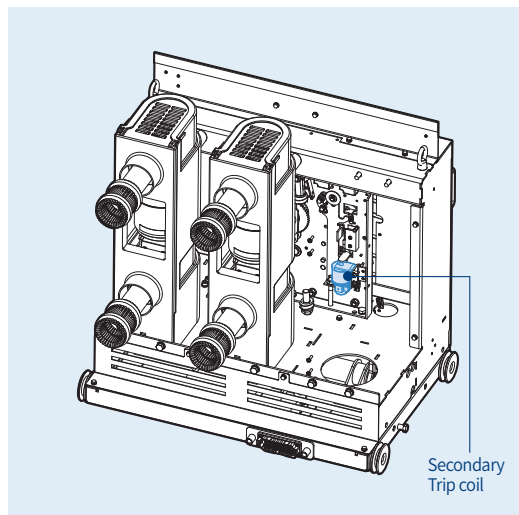

Input voltage (Vn)	UVH type							
	DC 110V	DC 200~250V	DC 125V	DC 48~60V	AC 48V	AC 100~130V	AC 200~250V	
Rated current (A)	≤ 3.5	≤ 2.5	≤ 3.5	≤ 8	≤ 8	≤ 3.5	≤ 2.5	

Accessories

Rated operation and control voltage range

Rated control voltage range	DC Voltage range		Remarks
	Motor, Closing	Trip	
24	-	24-28	
48	38-56	28-56	
125	100-140	70-140	
250	200-280	140-280	
Applied standard	IEEE Std C37.04		

Note) In case of DC24V control source(M4, C4, T4, U4), it is recommended to be used through Rated Control Voltage.

Rated control voltage range	AC Voltage range	Remarks
	Motor, Closing, Trip	
24	-	
48	-	
120	104-127	
240	208-254	
Applied standard	IEEE Std C37.04	

Auxiliary Contact: SA2/4, SQ2/4, SC2/4

Standard parts

UVL/UVM type

- A contact used to monitor OPEN/CLOSE status of a breaker remotely.
- The auxiliary contacts supplied as standard configuration is 4a4b. 10a10b is also available on request.

Item	Fixed type			
	UVL		UVM	
	4a4b	10a10b	4a4b	10a10b
Economic	-	SA4	SA2	SA4
Standard	-	SQ4	SQ2	SQ4

Item	Drawout type			
	UVL		UVM	
	4a4b	10a10b	4a4b	10a10b
Standard	-	SQ4	-	-
Auto-con	-	-	SC2	SC4

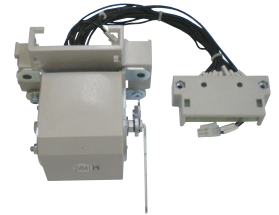
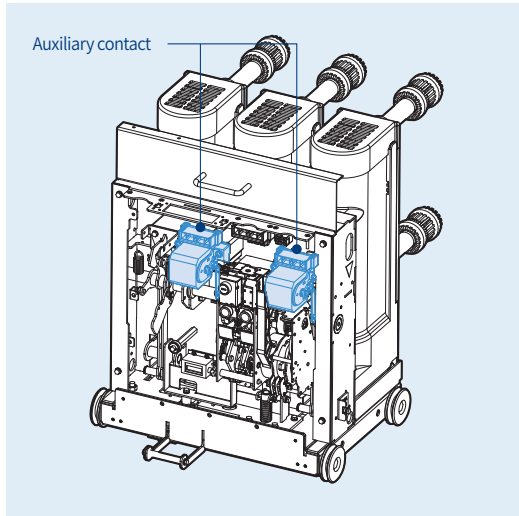

UVH type

Item	Fixed type		Drawout type	
	UVH		UVH	
	4a4b	10a10b	4a4b	10a10b
Economic	SA2	SA4	-	-
Standard	SQ2	SQ4	-	-
Auto-con	-	-	SC2	SC4

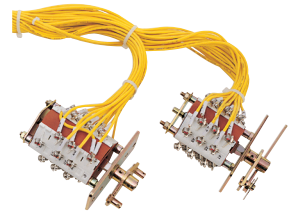
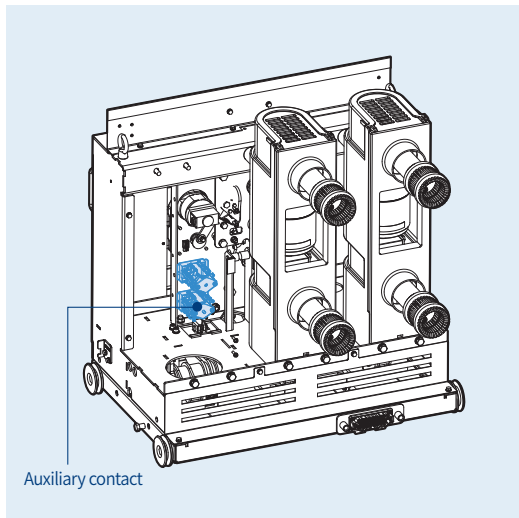

			UVL/UVM/UVH type		Remarks
Item			Resistive load (A)	Inductive load (A)	
Contact configuration	AC	250V	10	5	For all models
		125V	10	5	
	DC	250V	10	5	
		125V	10	5	
		30V	10	5	

Accessories

Under Voltage Trip Coil: U1~U8

Breaker Options

UVL/UVM type

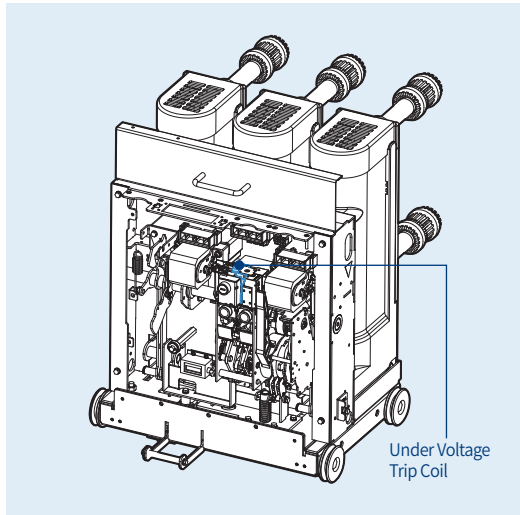

UVH type

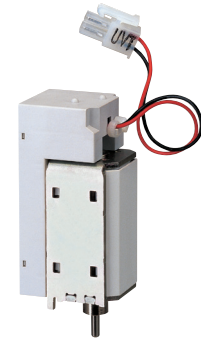
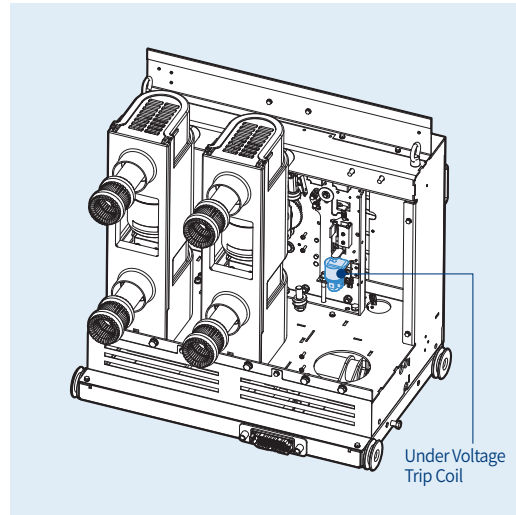

UVM type

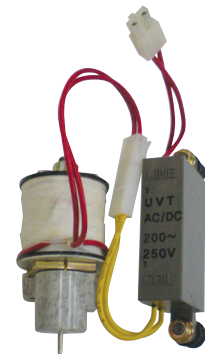

UVH type

- It is installed inside of a breaker to trip when the main power or control power voltage drops below certain value. Instantaneous type is only available with UVT coil and Time delay type is available by connecting UVT coil and UVT time delay controller.
- The closing of a circuit breaker is impossible mechanically or electrically if control power is not supplied to UVT. To close the circuit breaker, 65~85% of rated voltage should be applied.
- UVT and secondary trip coil will not be selected together.

* UVT is only applicable for Fixed type (P type)

1. UVT rated voltage and characteristic

- Operating voltage range: Pick up 0.65~0.85Vn, Drop out 0.4~0.6Vn
- Operating voltage ranges based on the minimum value of each rated voltage (Vn)

Input voltage (Vn)	UVL/UVM type							
	DC 110V	DC 200~250V	DC 125V	DC 24~30V	DC 48~60V	AC 48V	AC 100~130V	AC 200~250V
Power consumption (inrush, VA)	200							
Power consumption (steady, VA)	≤ 5							

Input voltage (Vn)	UVH type						
	DC 110V	DC 200~250V	DC 125V	DC 48~60V	AC 48V	AC 100~130V	AC 200~250V
Power consumption (inrush, VA)	350						
Power consumption (steady, VA)	≤ 10						

Position Switch: A3, A4, A5

Breaker Options

UVL type

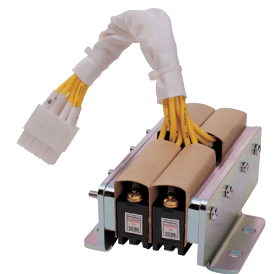
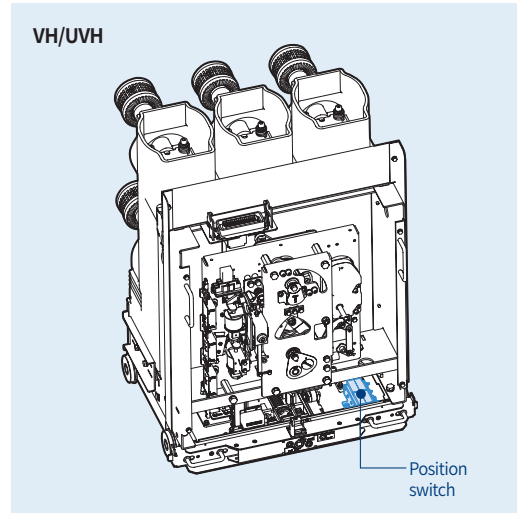
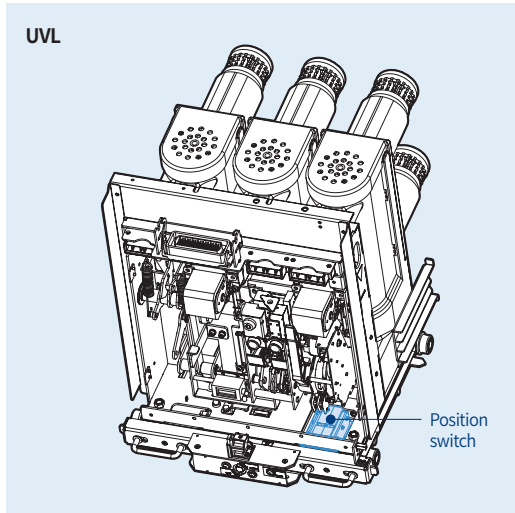

Large model (VH/UVH)

- This switch is used to indicate the breaker position (CONNECT, TEST), and contact configuration is 2a2a or 2a2b, 1a3b.

Contact configuration

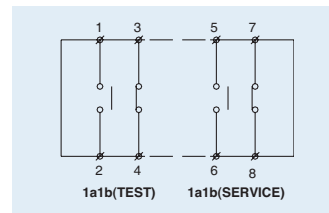
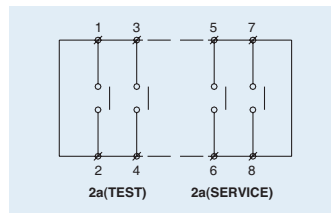
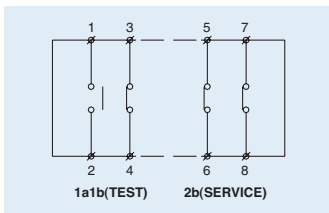

Latch checking switch: A6

Breaker Options

UVH type

- This switch works in conjunction with the mechanism of the breaker. It checks if the breaker is ready to be closed.
- When the mechanism is OFF and the closing spring is at charged status the switch becomes "ON", which means the mechanism is ready to be closed.
- If the latch is not in a proper position the switch prevents the breaker from closing. In case of VH type it is connected internally in series with the closing coil.

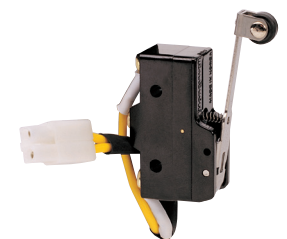
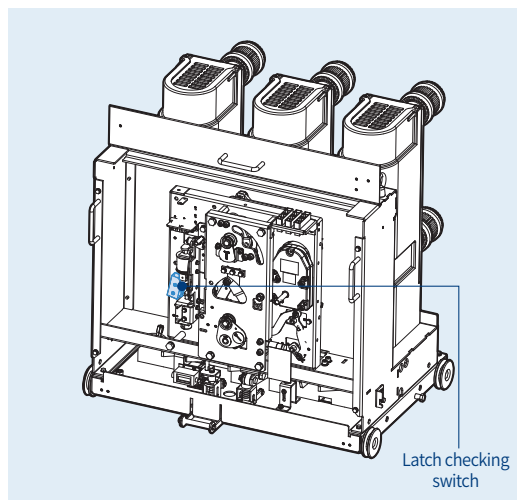

Accessories

Keylock: A7, AG, AM, AN, AP

Breaker Options

UVL/UVM type – A7, AG, AM, AN, AP

- The key is used to unlock the locking device before attempting to close the breaker electrically or mechanically.

*How to operate

- It is only possible to pull out the key in the locked position.
- Push the "OPEN" switch of a breaker, turn the key counter-clockwise to the locked position and pull it out.
- Cannot close the breaker electrically or mechanically in the locked position.
- Insert the key and turn it clockwise to unlocked position. Then the breaker can be closed.

1. A7: KEYLOCK(NORMAL Type)
2. AG: KEYLOCK (SAME KEY)
3. AM: KIRKKEY LOCK(CAMLOCK Type)
4. AN: KIRKKEY LOCK(CN22 Type)
5. AP: KIRKKEY LOCK(DOUBLE CAMLOCK Type)

* The KIRKKEY is not provided separately when ordering AM, AN or AP option. The assembling bracket and instruction manual are provided.

* Refer to the kirk key order information below.

- 1) AM, AP: Type "C" CAMLOCK(Part number: KCAM00010)
- 2) AN: Type KC40(Part number: KC40 -10)

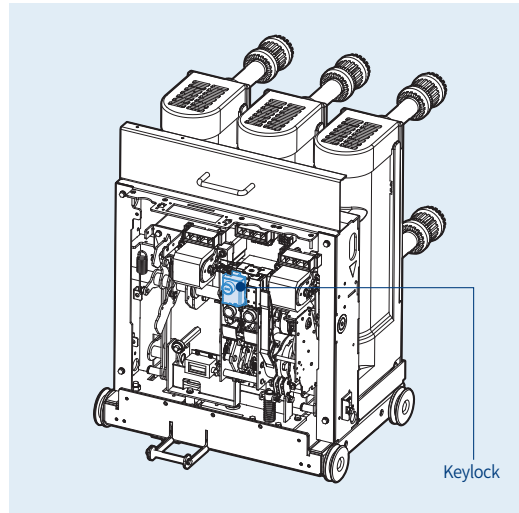

A7, AG

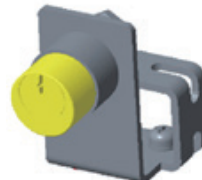

AM



AN

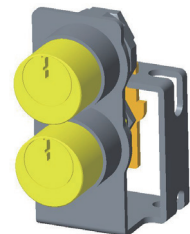

AP

UVH type - A7, AG, AM

*How to operate

- The key is used to unlock the locking device before attempting to close the breaker electrically or mechanically.
- Cannot close the breaker electrically or mechanically in the locked position.
- Make sure the breaker is open before using the key. Turn the key counter-clockwise to the locked position and pull it out.

1. A7: KEYLOCK(NORMAL Type)
2. AG: KEYLOCK (SAME KEY)
3. AM: KIRKKEY LOCK(CAMLOCK Type)

* The KIRKKEY is not provided separately when ordering AM option. The assembling bracket and instruction manual are provided.

* Refer to the kirk key order information below.

- 1) AM: Type "C" CAMLOCK(Part number: KCAM00010)

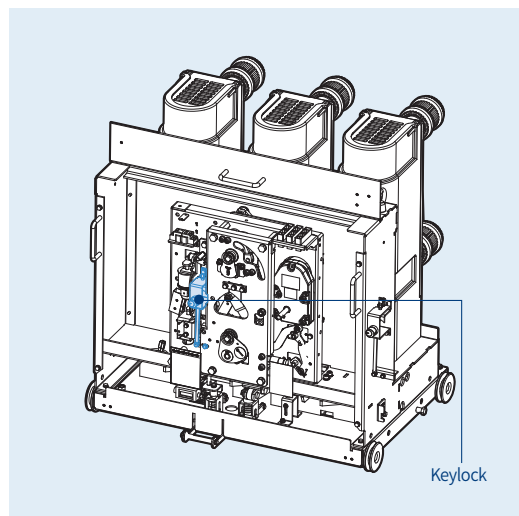

Button Padlock: A8, AX

UVL/UVM type

- It prevents manual operation of the OPEN/CLOSE button.
- A8 option: Cannot manually operate when the padlock is locked.
- AX option: Cannot manually or electrically operate when the padlock is locked.

* Key lock is not supplied.

1. A8: Normal type Button Padlock
2. AX: Button Padlock In open (UVM type only)

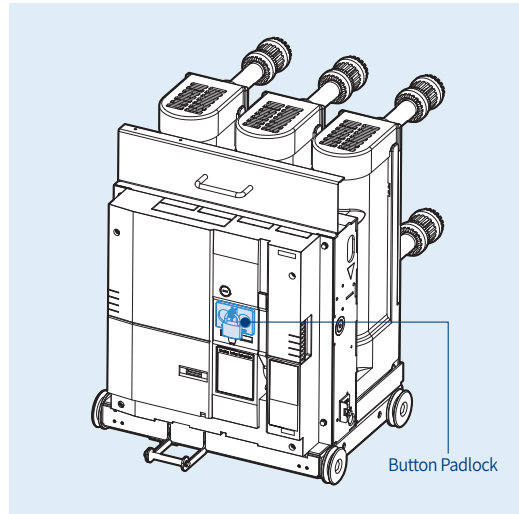

Breaker Options



UVL/UVM type

UVH type

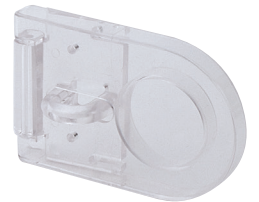
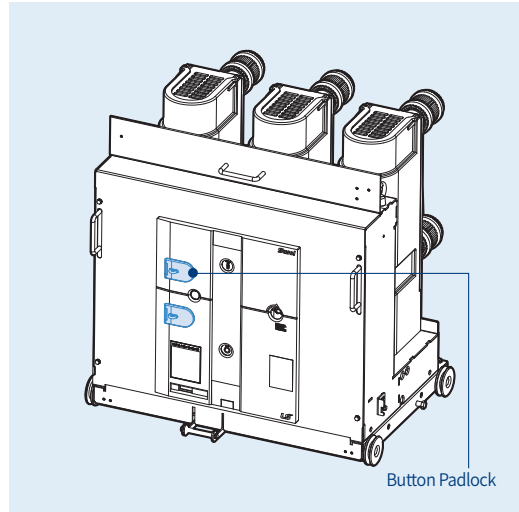

UVH type

Accessories

Lead wire: AA(breaker option) or A1,A2(Cradle option)

UVL/UVM/UVH type

- Connects to the controls of the circuit breaker (wire length: 2m)
- A/Q type connector is supplied for P type of UVM/UVH VCB.

Note) Standard Lead wire length is 2m. If you need extra length, please contact LS sales.

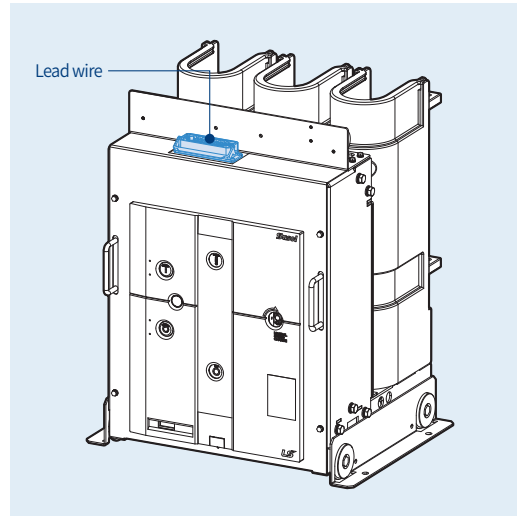

Breaker Options



A type connector

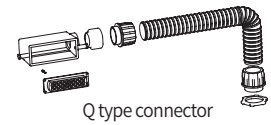

Q type connector

Supply ways of Lead wires by VCB model

VCB model	Cradle type	P	H
UVL/UVM		Enclosed in the breaker	Enclosed in the breaker Installed in the cradle (option)
UVH		Enclosed in the breaker	Enclosed in the breaker Installed in the cradle (option)

Plug/Terminal for lead wire: AB

Breaker Options

UVM/UVH type



A type connector



Q type connector

- It is connector to connect with the connector installed in the breaker. (supply connectors and terminal only for lead wire)
- Type of connector is depends on the type of connector installed in the breaker- A or Q.
- Distance of flexible tube: 600mm(23.6 inch)

Plug interlock: AC

Breaker Options

UVL type

- Verifies if the control power on the cradle (H-type) is connected to the terminal of the breaker before drawing in or out.
- Does not allow the separation of the control power connector from the breaker in draw-in/out or CONNECT position. It is possible in test position.

Padlock/Door racking interlock: AD

Breaker Options

UVL type

- Allows draw-in/out with the door closed.
- When draw-in/out is necessary while the door is open, use the operation lever.
- Optional padlock prevents draw-in/out of the breaker in the TEST AND CONNECT position.

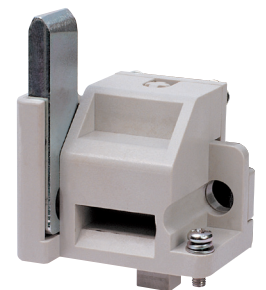
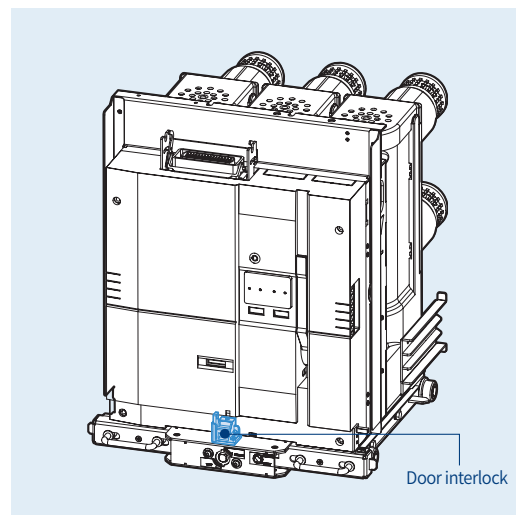

Accessories

MOC operator: AE

UVL/UVM type

- It must be installed in the breaker to operate the MOC installed in the cradle.
- MOC, Mechanically operated cell switch is the device to indicate the CLOSE/OPEN status of VCB in 'TEST' and 'CONNECT' position.
- This MOC operator in the breaker should be installed when MOC in the cradle is used.

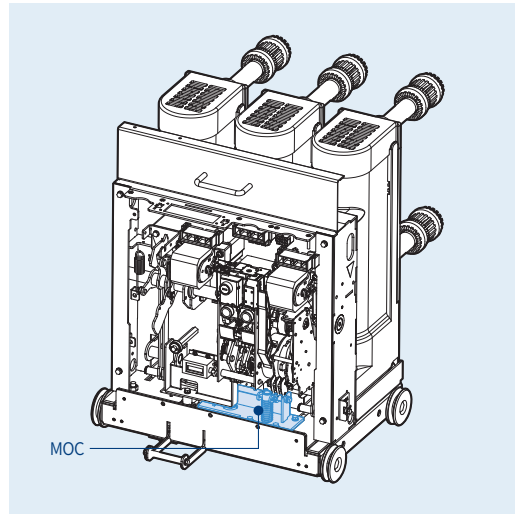

Breaker Options

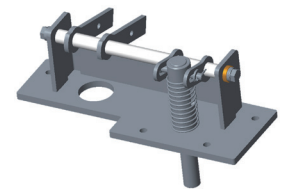

<UVM>

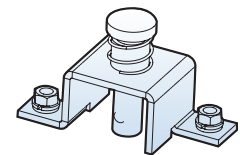

<UVL>

UVH type

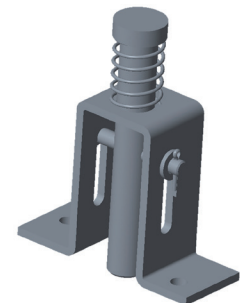
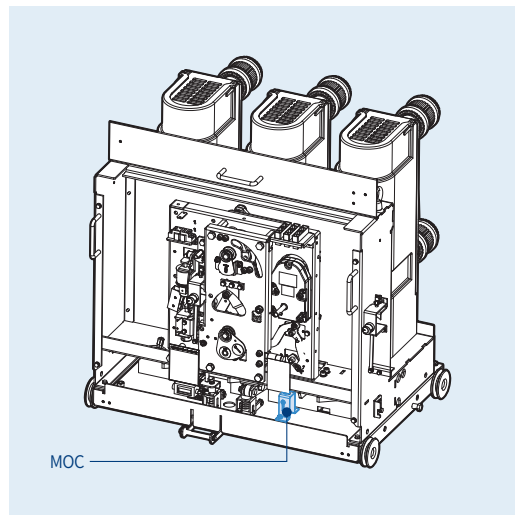

<UVH-05/15>

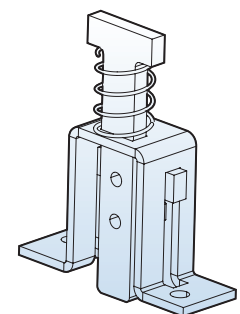

<UVH-38>

Auxiliary Wheels(Direct Roll-in): AS

Breaker Options

UVM/UVH-05/15/27H

- The direct roll in option is designed for inserting in and out the circuit breaker without any special device.
- Wheel kits assembled on both sides.
- Without any modification of CB compartment, it is possible to roll the circuit breaker in and out.

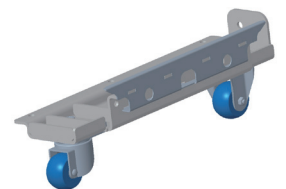
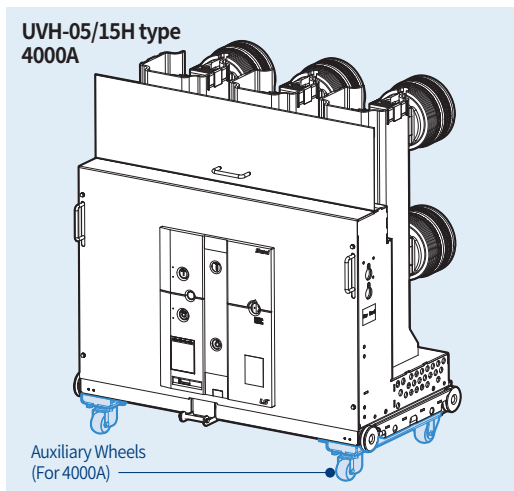
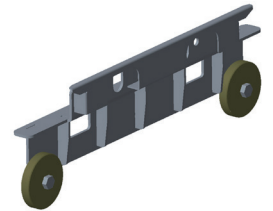
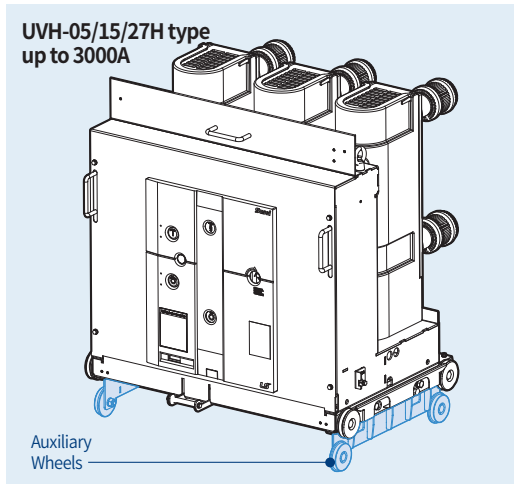
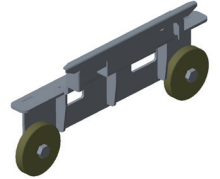
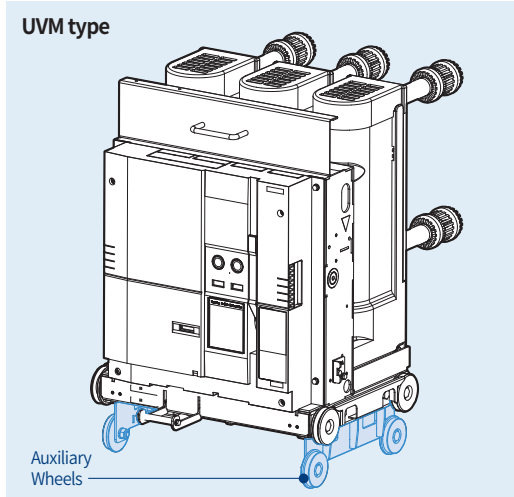

Trip coil monitoring contact: A2

Breaker Options

UVL/UVM type

- Device for monitoring the functions of the trip coils.
- Supplied as standard for UVM model and optional for UVH model.
- To monitor the trip coils, connect its terminals with the trip coil monitoring relay as shown in the circuit diagram.
 - if the trip coil is normal - circuit is closed
 - if the trip coil is damaged - circuit is open
- 1) Terminals A5 and A6 monitor the trip coils in closed position of the breaker.
- 2) Terminal A6 and aux. contact terminal 34 monitor the trip coils in trip position of the breaker.
- Coil Test Unit is optional, which enable monitoring the coils by connecting in parallel with the trip coil operation switch.
- In case of UVM type this contact works with the trip coils such as T1, T2, T3, T4 and T5.
For UVH type it works with all trip coils.

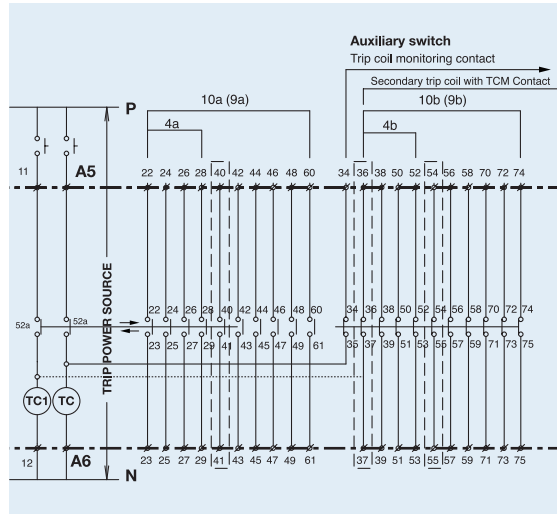

UVH type

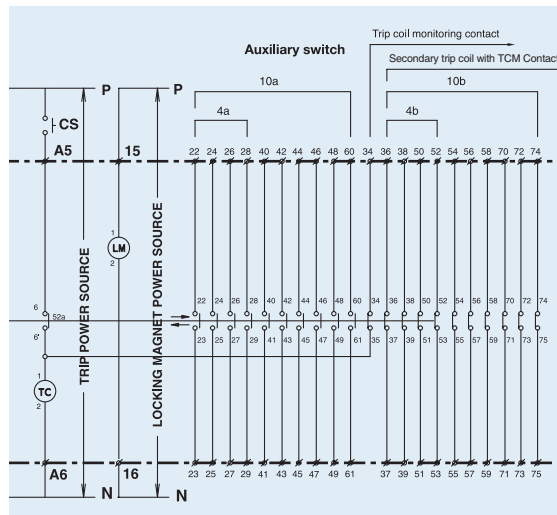

Coil Test Unit: CTU

Breaker Options

UVL/UVM/UVH type

- When no current flows through the coil it gives the test current which does not cause the coil to operate to check whether the coil is disconnected or not.
 - If the test current flows normally: coil normal
 - If the test current does not flow through: coil disconnected

- ※ As it is connected in parallel with the control part of the coil the normal operation of the coil is not affected.
- ※ Monitoring of the running coils is not possible.
- ※ One test unit can monitor up to two coils.

1. Input voltage: AC/DC 75V~264V
2. Contact output
 - 1) 2×a contacts for Fail indication and 2×a contacts for Alarm
 - 2) 250Vac/10A Resistive, 30Vdc/10A Resistive
3. Disconnection test cycle is 12 seconds (Test LED blinks)
4. The default operation
 - If failure occurs (coil disconnected), Fail LED turns on and the Fail contacts become short state.
 - If failure occurs three times in series, Alarm LED turns on and the Alarm contacts become short state.
 - In order to clear the Alarm status push up DIP switch on the front and then push down it (Off → On → Off)

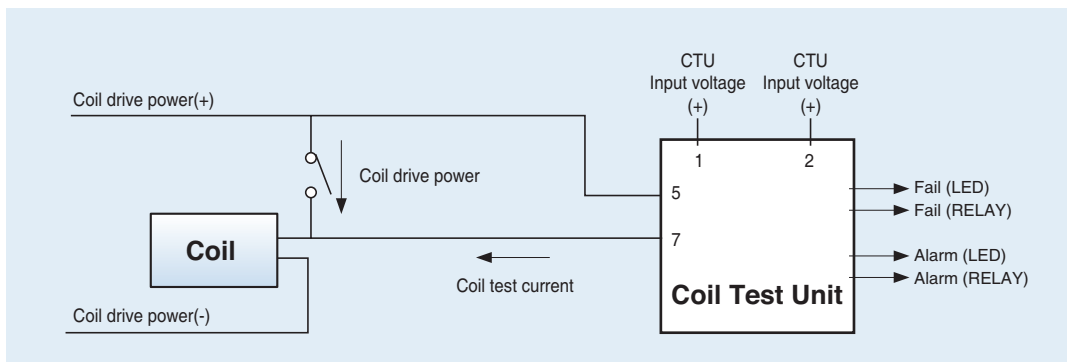
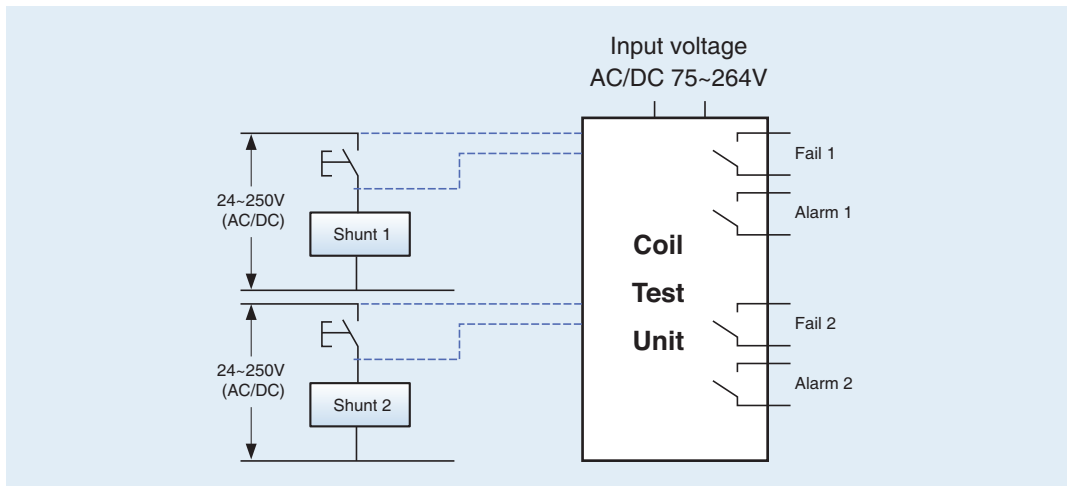
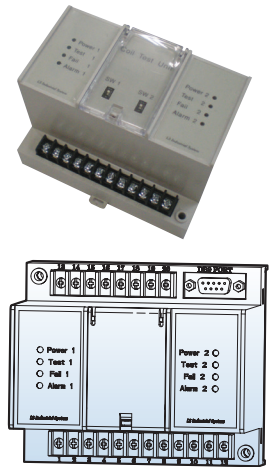

Accessories

Condenser trip device: CTD

Breaker Options

Ratings

Ratings	Specification	
Model	CB - T1	CB - T2
Rated input voltage (V)	AC 100/110	AC 200/220
Frequency (Hz)	50/60	50/60
Rated charge voltage (V)	140/155	280/310
Charging time	Within 10sec.	Within 10sec.
Trip possible time	Within 30sec.	Within 30sec.
Range of Input voltage	85%~110%	85%~110%
Condenser capacity (μF)	1,000	560

UVL/UVM/UVH type

- It is a device that electrically trips the circuit breaker within a certain period of time when the control power is turned off. It is used in combination with a trip coil.
- Even in the event of a power failure, a trip is possible within 30 seconds. However, the automatic trip circuit after power failure must be separately configured in the switchgear.



Terminal arrangement

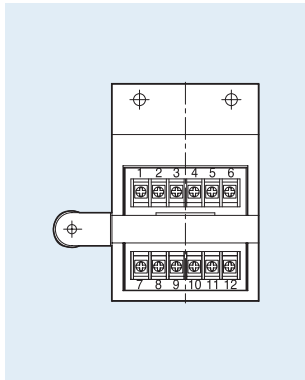

External dimension

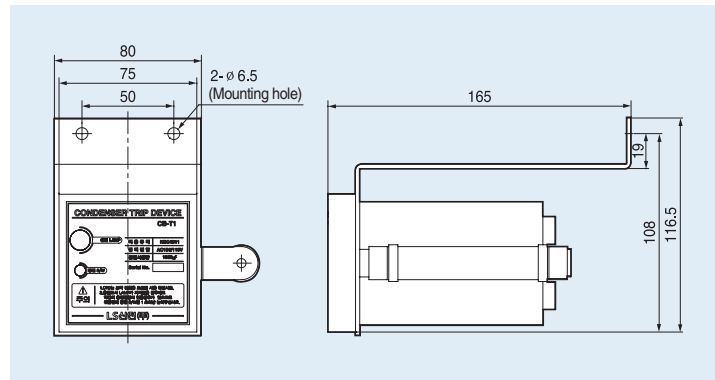

Circuit diagram

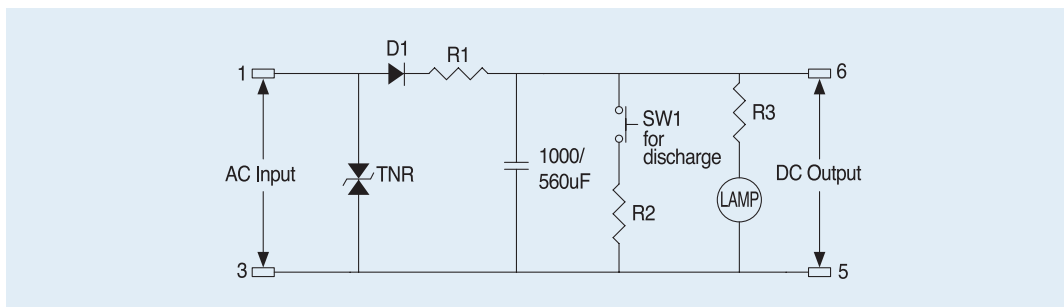

UVT Time delay: UDC

UVL/UVM/UVH type

- UVT time delay, UDC is to delay the trip signal from UVT.
Without UDC the breaker will be tripped instantaneously by the trip signal from UVT installed inside of the breaker even in the the momentary power failure.
- UDC can delay the trip time to avoid this unintended instantaneous trip in the event of such power failure.
- It can be installed on the cradle or inside of the switchgear.
- UDC provides output contacts for indication of trip status due to the UVT coil inside of the breaker.
b contact is closed at normal state and a contact is closed at trip.

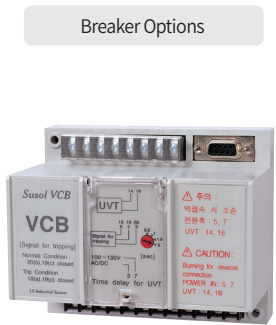

1. Characteristics

Rated voltage (Vn)		Operation voltage range (V)		Consumption (VA or W)		Time delay (ms)
DC (V)	AC (V)	Pick up	Drop out	Inrush	Steady - state	
48~60	48	0.65~0.85 Vn	0.4~0.65 Vn	200	≤ 5	0.5, 1, 1.5, 3
100~130	100~130					
200~250	200~250					

- Operating voltage ranges are based on the minimum value of each rated voltage (Vn)

2. Ratings of output contacts

Rated voltage (V)	Rated current (A), Resistive load	Max. switching voltage (A)	Max. switching current (A)
24V DC	≤ 12	110V DC 250V AC	15
120V AC	≤ 12		
250V AC	≤ 10		

3. Wiring diagram

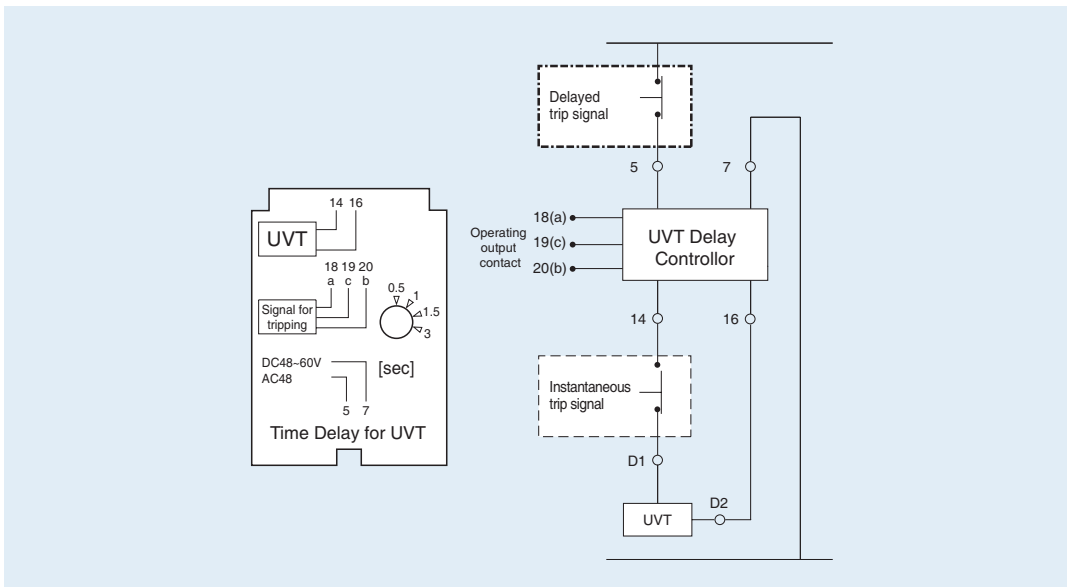

Accessories

Shutter padlock

UVL/UVM/UVH type

- It is the locking device to lock the primary and secondary shutter in closed state for safety while the breaker is drawn out for maintenance.
- When the breaker is drawn in, the shutter is automatically opened.
- There is a hole for padlock to lock the shutter.
- It can be applied only to H type cradle.

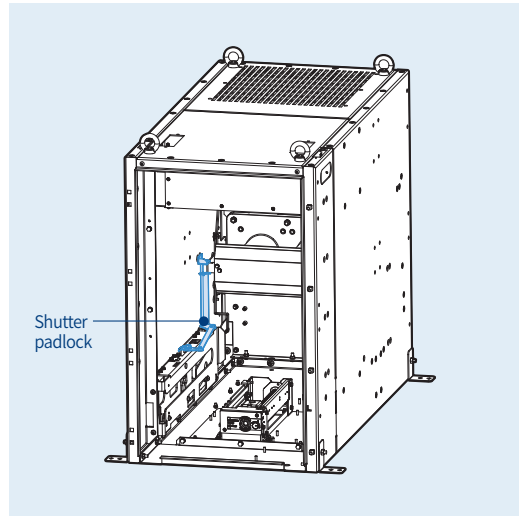

Cradle Options

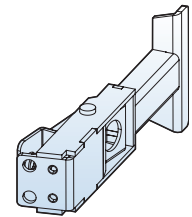

<UVL/UVH-38>



<UVM/UVH-05/15/27>

Truck operated cell switch (TOC)

UVL/UVM/UVH type

- This auxiliary switch is used to indicate the 'CONNECT' position of VCB. It is installed in the bottom of a cradle and operated by the frame of a breaker.
- The auxiliary contacts supplied is 6a6b.

Circuit diagram (UVM/UVH-05/15/27 Type)

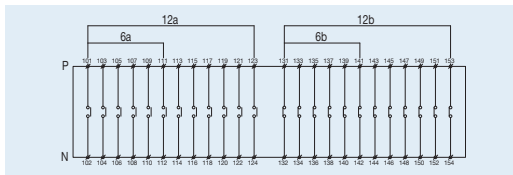

- a Contact: 101-102, 103-104, 105-106, 107-108, 109-110, 111-112, 113-114, 115-116, 117-118, 119-120, 121-122, 123-124
 b Contact: 131-132, 133-134, 135-136, 137-138, 139-140, 141-142, 143-144, 145-146, 147-148, 149-150, 151-152, 153-154

Circuit diagram (UVL/UVH-38)

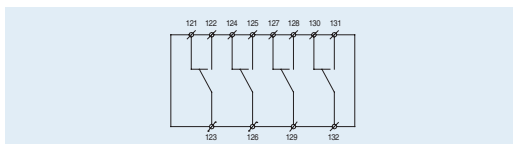

- a Contact: 122-123, 125-126, 128-129, 131-132,
 b Contact: 121-123, 124-126, 127-129, 130-132

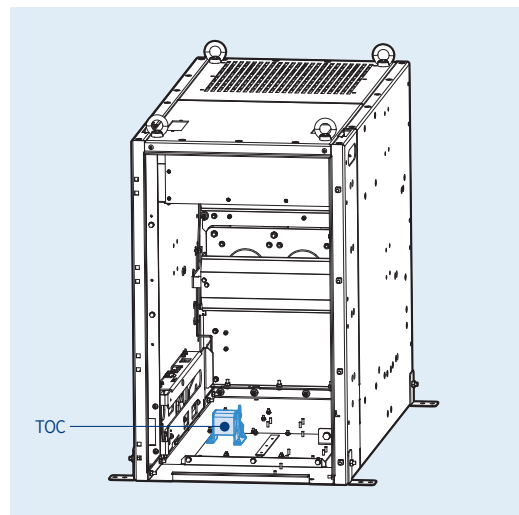

Cradle Options

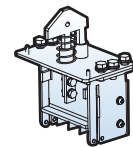

<UVL>

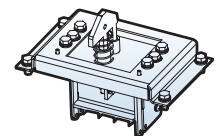

<UVH-38>

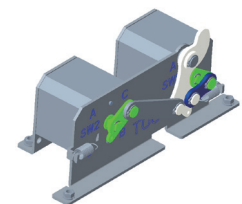

<UVM/UVH-05/15/27>

Mechanical Operated Cell Switch (MOC)

UVM/UVH type

- This auxiliary switch is used to indicate the Close/Trip of VCB. It is operated mechanically at the 'TEST' and 'CONNECT' position. It is installed on the bottom of a cradle and operated by the part of a breaker.
- The auxiliary contacts supplied as standard configuration is 6a6b. 12a12b is also available on request.

Circuit diagram (UVM/UVH-05/15/27)

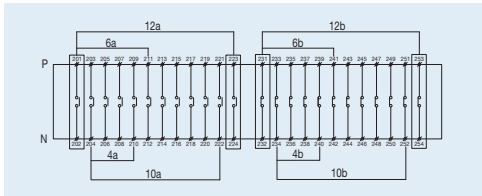

a Contact: 201-202, 203-204, 205-206, 207-208, 209-210, 211-212, 213-214, 215-216, 217-218, 219-220, 221-222, 223-224
 b Contact: 231-232, 233-234, 235-236, 237-238, 239-240, 241-242, 243-244, 245-246, 247-248, 249-250, 251-252, 253-254

※ In case of selecting Remote Racking System, maximum contacts are 4a4b, 10a10b respectively.(Blocked contacts of diagram are not included.)

Circuit diagram (UVL/UVH-38)

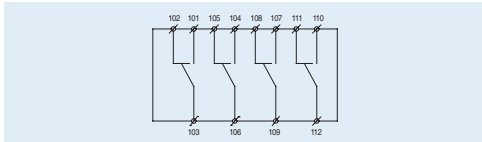

a Contact: 101-103, 104-106, 107-109, 110-112,
 b Contact: 102-103, 105-106, 108-109, 111-112

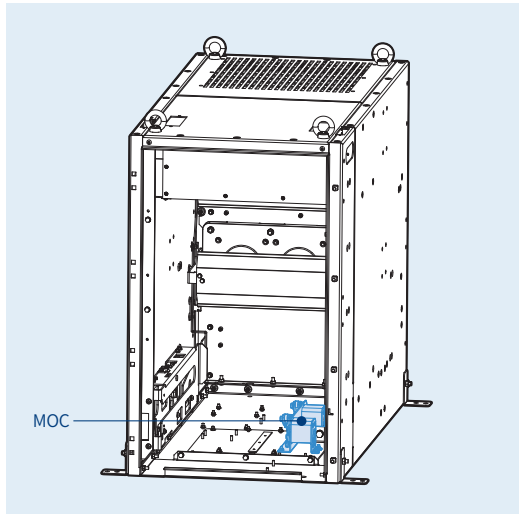

Cradle Options

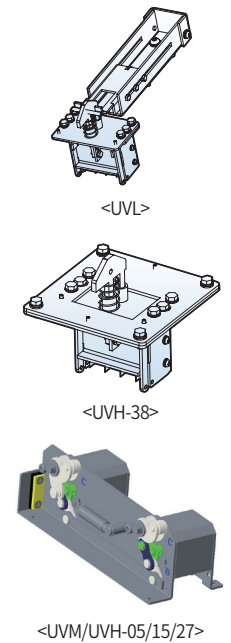

Padlock/Door racking interlock: A5

UVM H-type/UVH-05/15/27 H type

- With this door options for H type cradle draw-in/out is allowed only when the door is closed.
- Padlock is also optional, which can lock to prevent the draw-in/out of the breaker.

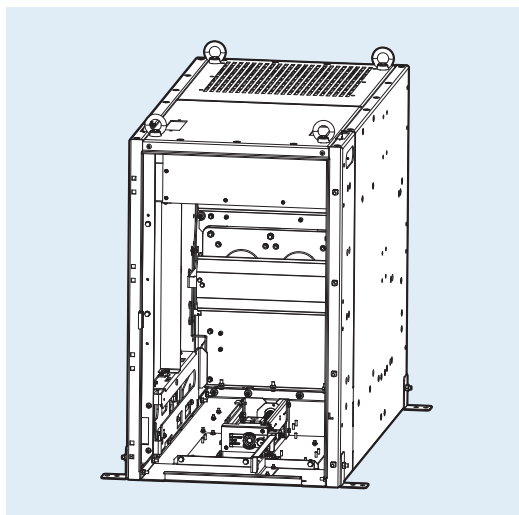

Cradle Options

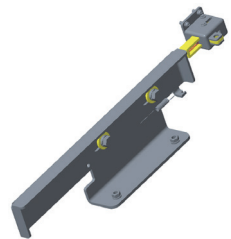

Accessories

Kirkkey Interlock: A9

UVM H-type/UVH-05/15/27 H type

- The kirk key interlock prevents the racking in/out of the breaker by blocking block ass'y.
- In case of selecting Remote Racking System(RRS), it must be selected.

* The KIRKKEY is not provided.

** KIRKKEY part number: KFL010010

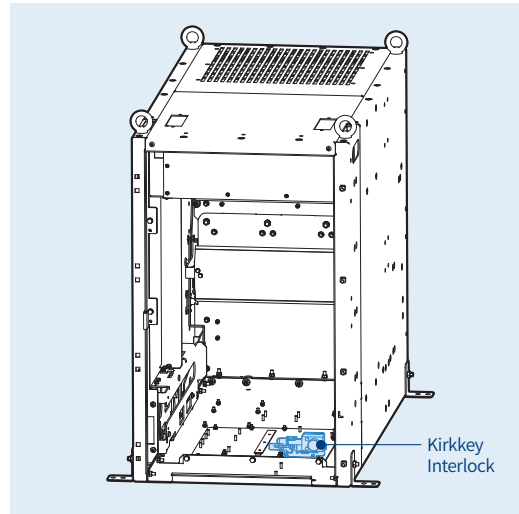

Cradle Options

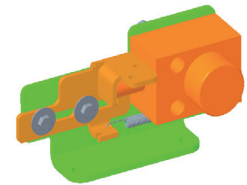

Door: AH

UVL/UVM/UVH H-type

- It is outside door for H type cradle.
- Accessories are available for the door.

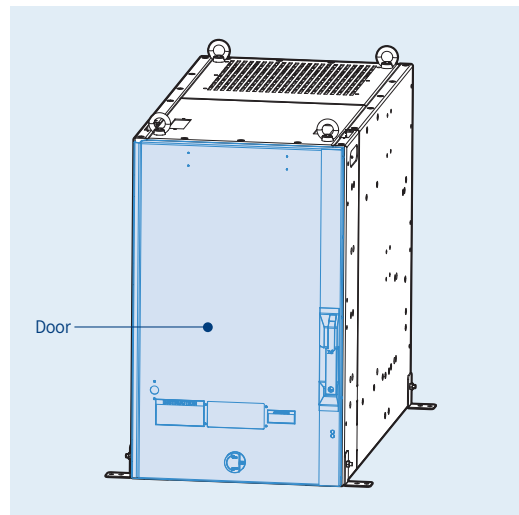

Cradle Options



Door Interlock: AJ

UVL/UVM/UVH H-type

- The door interlock prevents the cradle door from opening when the circuit breaker is not in the "disconnect" position.

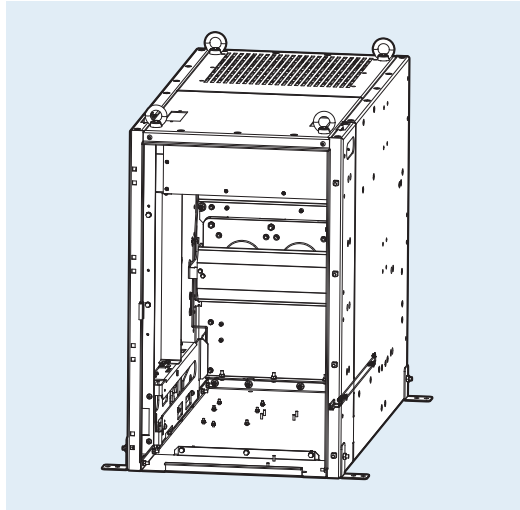

Cradle Options



Door Emergency Push button: AK

UVL/UVH-38 H-type

- It is used to enable the Close/Trip of the breaker manually from outside of the door installed to H type cradle during an emergency.
- Push the ON/OFF button by ON/OFF handle supplied separately.

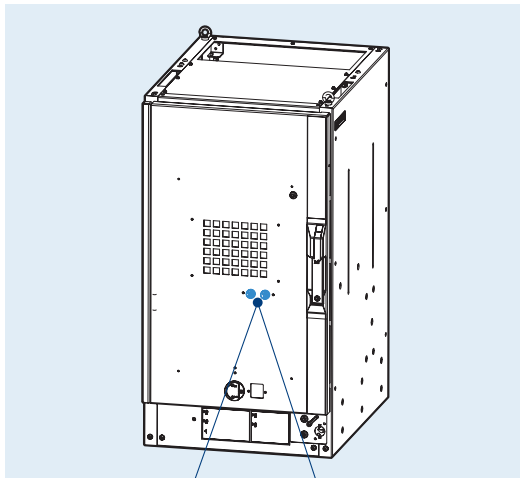

Cradle Options

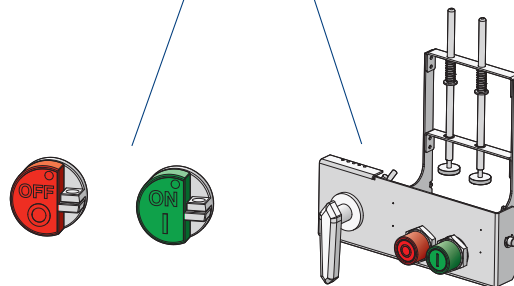
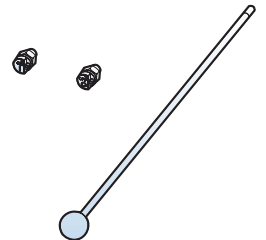

Door Emergency Push button

Accessories

Door Padlock

UVL/UVM/UVH H-type

- It is supplied with a door for H type cradle as standard.
- It can be locked by separate padlock to prevent the use of the manual handle.

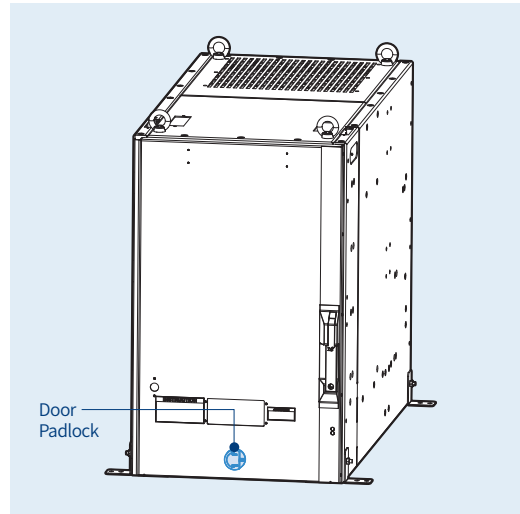

Standard parts

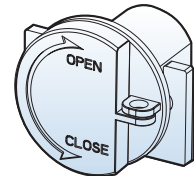

Position padlock

UVH-38H-type

- It is located at the screw hole to prevent the draw-in and out of the breaker from any position.

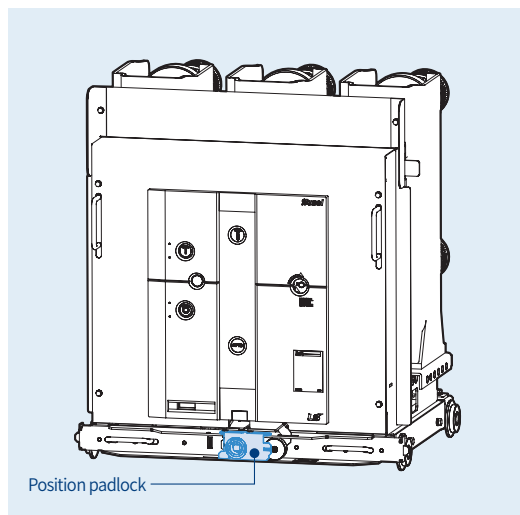

Standard parts

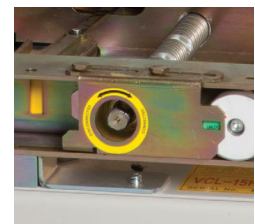

Motor Control Racking System (Remote Racking System, AA~AH)

Standard parts

UVM/UVH-05/15/27 H type

- The motor control racking system (MCRS) provides the ability to rack the circuit breaker in and out remotely.
- The circuit breaker can be moved to a designated position in the cradle using a remote control device.
- The MCRS supports 2 safety features and 11 error modes related to motor operation. These error modes can be delivered to the user in real time through either the remote controller or RS485 communication, and protects the user from accidents caused by failures.
- Communication Port supports RS485 and RJ45(Pendant, PLC, Modbus)
- MCRS is certificated by FCC* and IC**

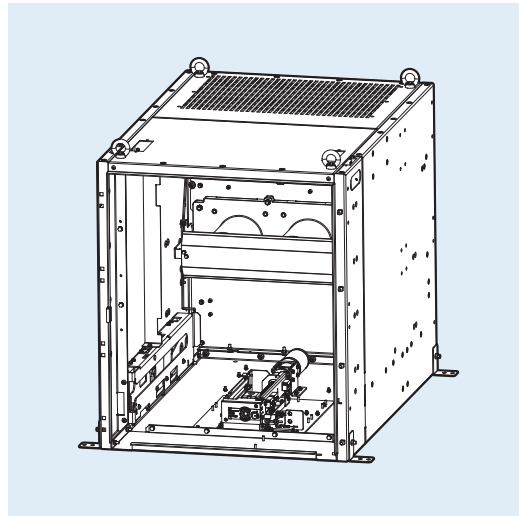

* FCC: Federal Communications Commission
 ** IC: Industry Canada

* Modbus RS485
 - Operation mode: Differential
 - Distance: Max. 1.2km
 - Cable: General RS485 shielded twist 2-pair cable
 - Transmission method: Half-Duplex
 - Modbus address: 0-255ch
 - Baud rate: 9600bps, 19200bps, 38400bps, 57600bps, 115200bps
 - Termination: 100Ω

1	Input Power(+)	1	Frame Ground Connection
2	Input Power(-)	2	DISCONNECT Position Micro S/W(R1, R2)
3	Motor Output Power(+,-)	3	TEST Position Micro S/W(R3, R4)
4	MCB & MOC(M1, M2) Connection	4	CONNECT Position Micro S/W(R5, R6)
5	Modbus Control Connection(RS485)	5	PLC Function Use S/W Connection
6	Modbus Control Connection(RJ45)	6	MCRS Key Lock Connection(R9, R10)
7	MOC Close("a" Contact : 201, 202)	7	User Interlock Connection(GPIO2)
8	MOC Open("b" Contact : 231, 232)	8	PLC Control Connection(RJ45)
9	Manual Rack In/Out Micro S/W(R7, R8)	9	Pendant Control Connection(RJ45)

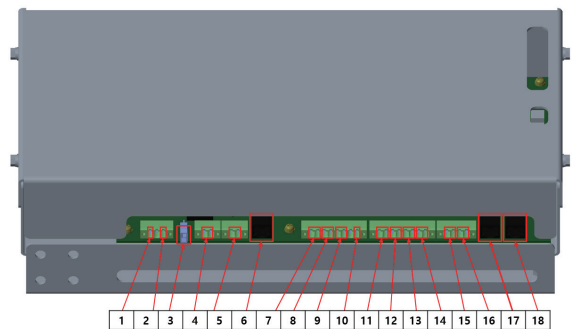

Accessories

Type of handle

Manual charging handle
(Only for UVH type VCB)

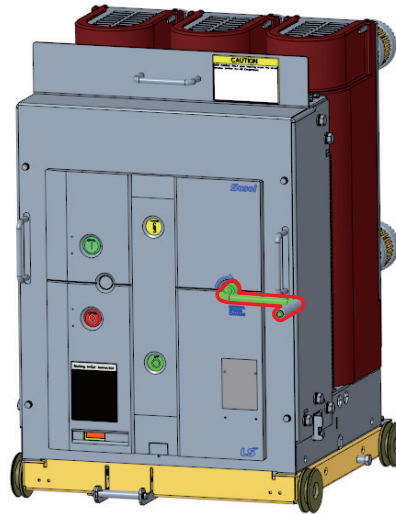

Code	Appearance
55213143046	

Racking in/out handle
UVL type

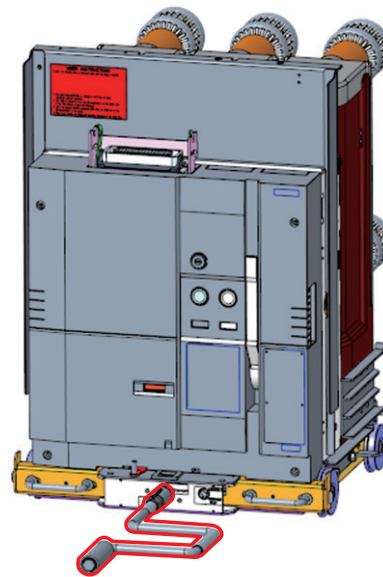

Description	Code	Appearance
Normal	55223172407	

Type of handle

UVM/UVH-05/15/27 L type

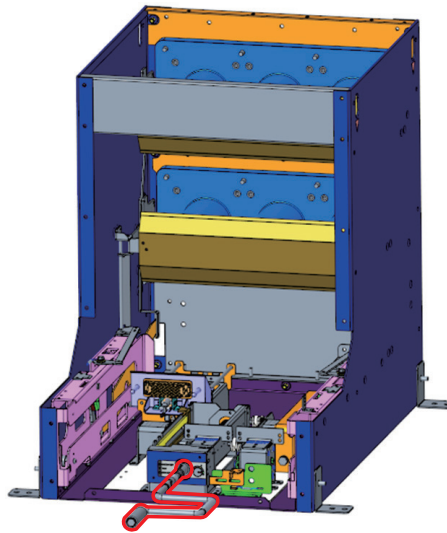

Description	Code	Appearance
Universal	55223172411	

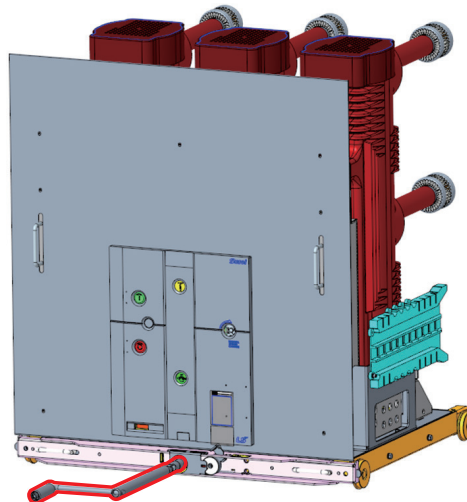

Description	Code	Appearance
Universal	55213163003	

Accessories







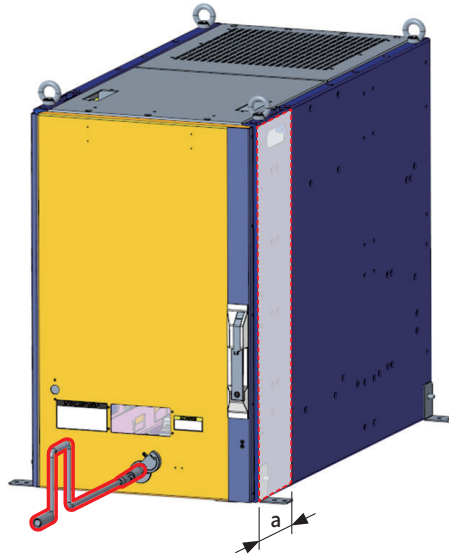

Type of handle

UVCM/UVCH-05/15/27 C,H type

- LS ELECTRIC's Susol UL VCB has two type of the compartment.
 - C-type : Conventional type of compartment (No space between panel door and CB)
 - H-type : New type of compartment which includes 10" space between panel door and CB for LV control panel.
- Therefore, type of compartment must be considered before chosen the racking in/out handle.
 - C-type: No space between the door and CB.
 - H-type: 10" space exist between the door and CB.

** However, 4000A VCB uses the C - type compartment handle only (55223181003 or 55223181004)



Compartment type	Description	Code	Appearance	
C	Universal	55223181003		
	MCRS, Universal	55223181004		
H	Universa	55223181001		
	MCRS, Universal	55223181002		

Type of extension rail

UVCM/UVCH-05/15/27 L,C,H type

- The extension rails are used to safely racking in/out the CB to the compartment.
- LS ELECTRIC's Susol UL VCB has two type of the compartment.
 - C-type : Conventional type of compartment (No space between panel door and CB)
 - H-type : New type of compartment which includes 10" space between panel door and CB for LV control panel.
- Therefore, type of compartment must be considered before chosen the extension rail.
 - C-type: No space between the door and CB.
 - H-type: 10" space exist between the door and CB.

** However, 4000A VCB uses the C – type compartment's extension rail only (59023181003)

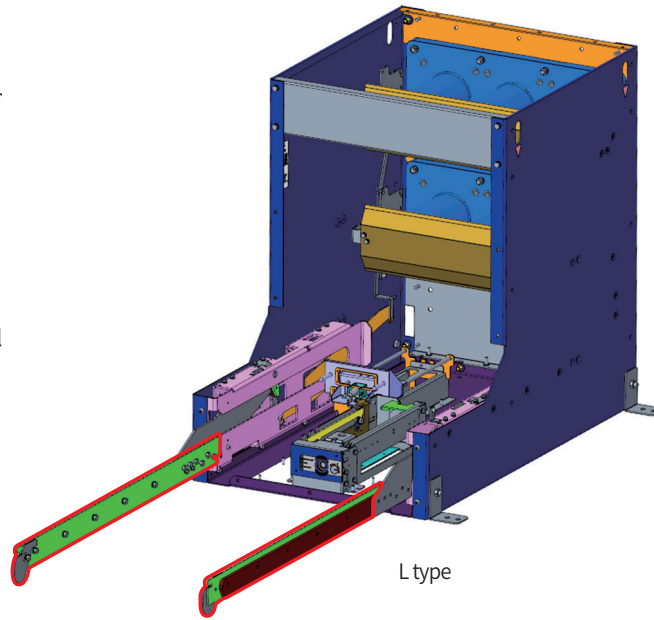



Type	Rating	Code	Appearance
L	4.76, 15 kV	59023181003	
	27 kV		

Accessories

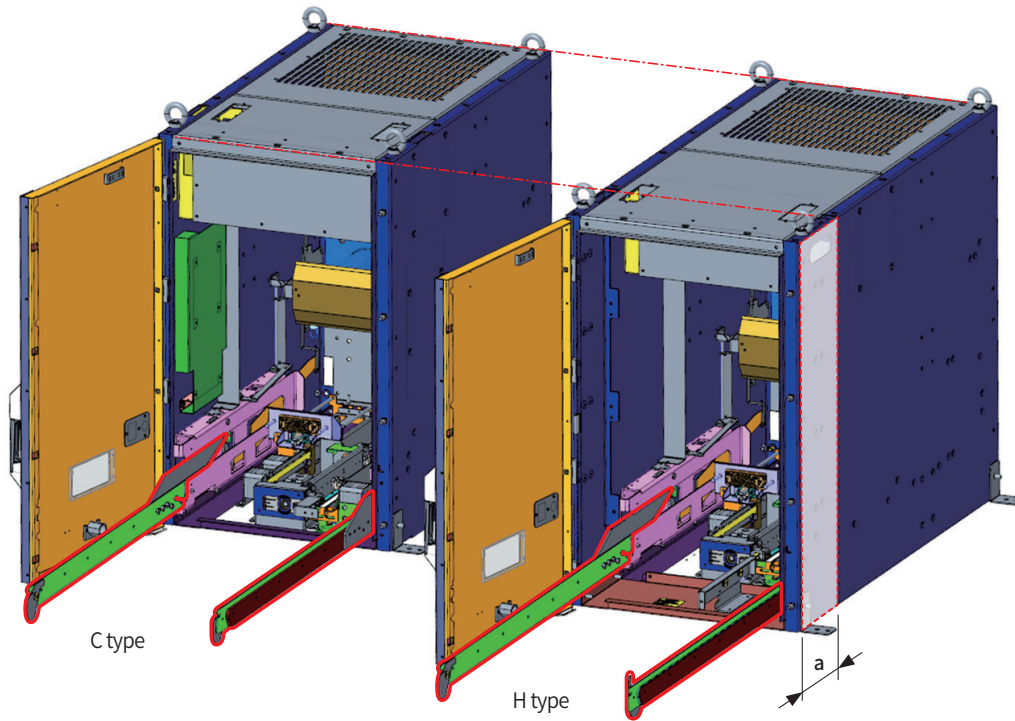
Type of extension rail

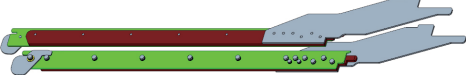

Type	Rating	Code	Appearance
C	4.76, 15 kV	59023181003	
	27 kV		
H	4.76, 15 kV	59023181009	
	27 kV		

VCB lifting bracket set

UVH-4.76/15kV 4000A, 27kV

- Lifting bracket set is used to pull up the VCB by using the hoist or cranes.
- This accessories are for the Susol UL VCBs which 4.76/15kV 4000A and 27kV series.
- The other rating of Susol UL VCB includes lifting eyes or eye bolts.

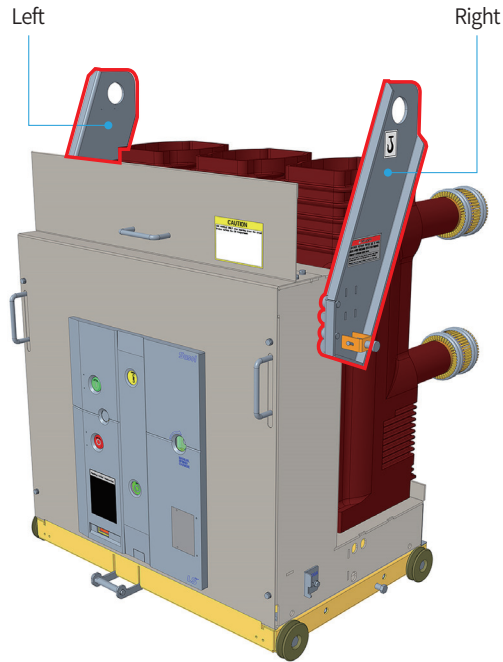

Rating	Code	Appearance
4.76/15kV 4000A	Left 75123173981	
	Right 75123173982	
27kV	Left 75123181011	
	Right 75123181010	

Accessories

VCB lifter

- The VCB lifter for LS ELECTRIC's Susol UL VCB.
- The VCB lifter hoists the VCB manually for putting on the extension rail for racking in or for putting on the ground.

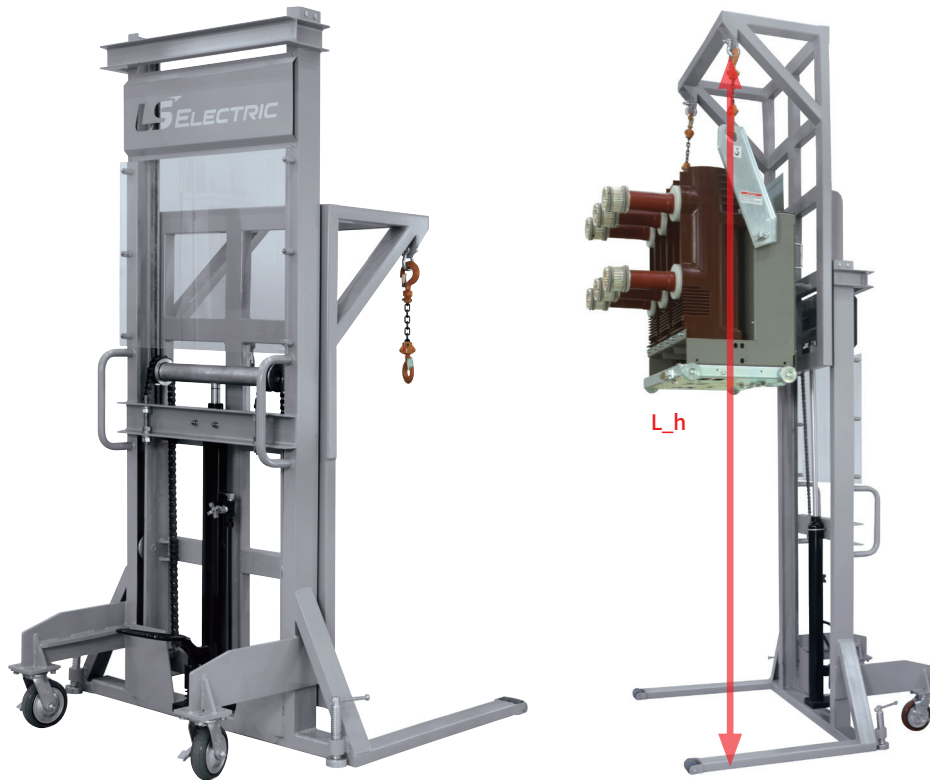

- The size of lifter(Normal, W×D×H): 48.4"×53.1"×86.6" / 1230×1349×2200(mm)
- The maximum height of lift(L_h): About 121.85"(3095mm)
- The maximum weight of load: About 881.85lb(400kg)

Item code	Description
0266000301	LIFTER, BCL15002_F870, W1212 H1965 D1119, FOR VCB(UVM, UVH)

Test cabinet

- The test cabinet is the device which operates “CLOSE” and “OPEN” when the VCB is racking out from the switchgear for maintenance or test.
- The Power supply is not provided.
- The connectors for each Susul UL VCB are provided.

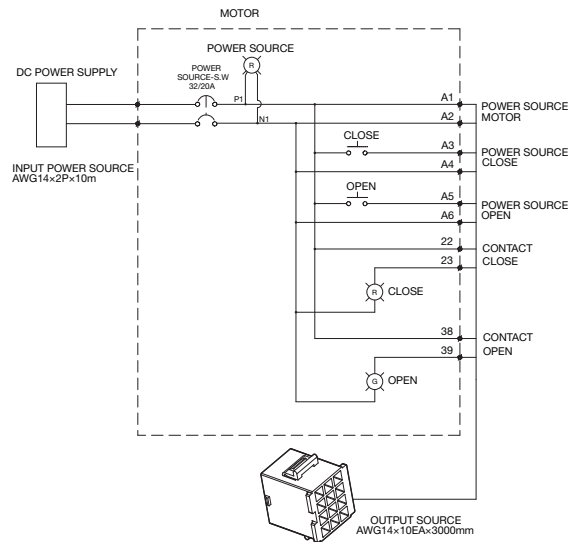
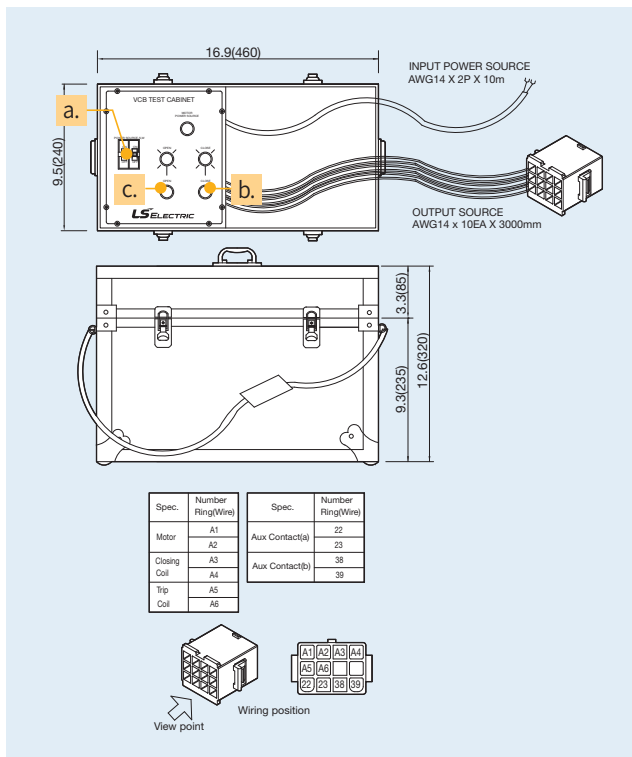

<Circuit diagram>

- a. Test Cabinet Power Switch
- b. Close Push Button
- c. Trip Open Push Button

Item code	Description
55213143046	DEVICE, VCB TEST CABINET, UL

Circuit diagram for VCB control in remote

UVL-05/15/27

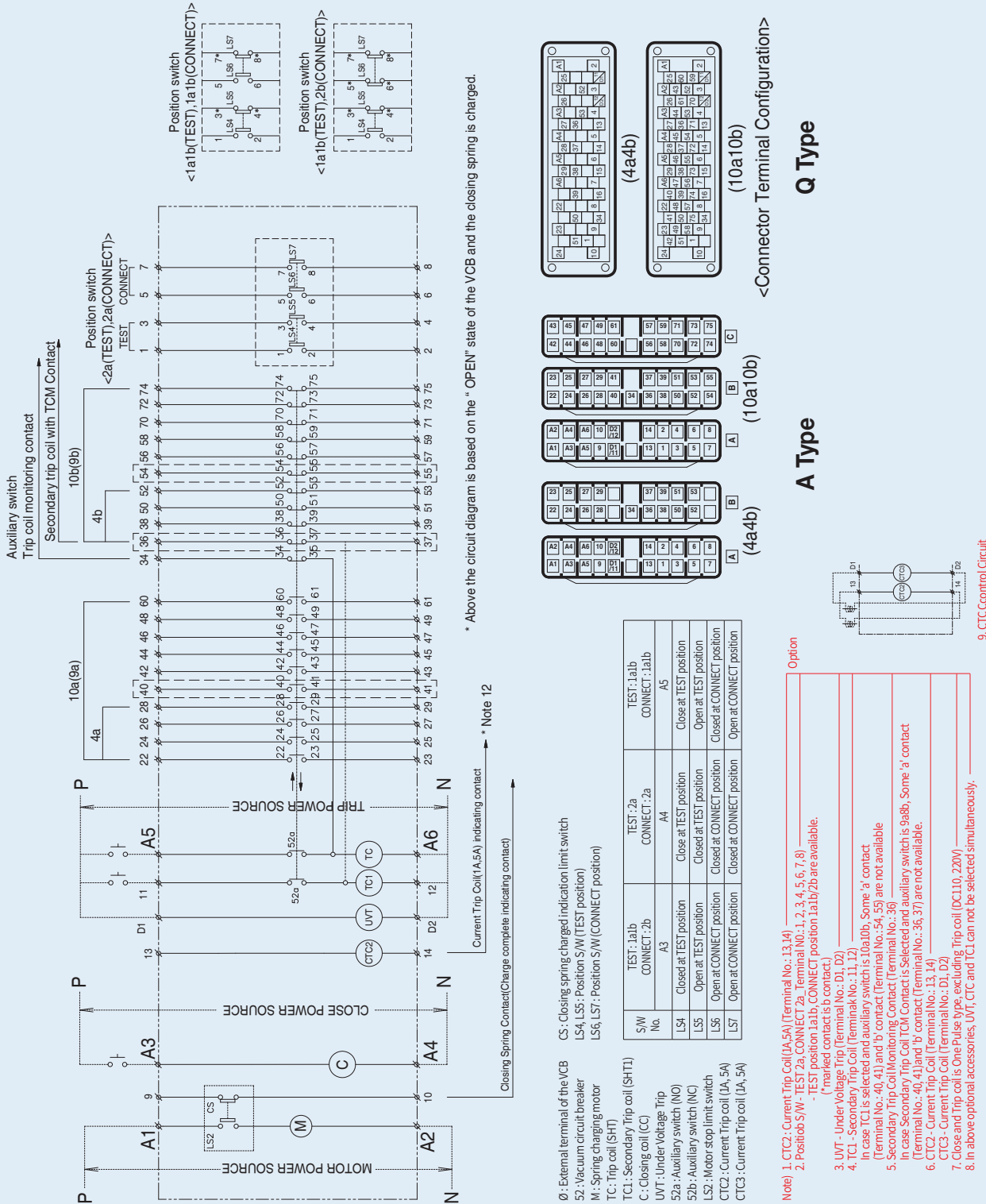

UVM-05/15

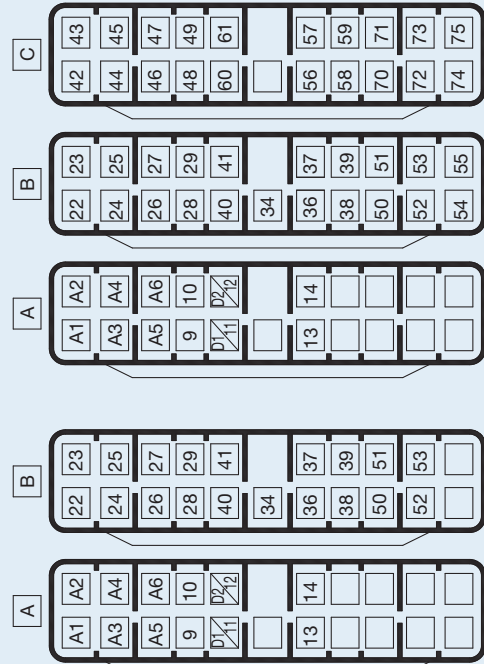
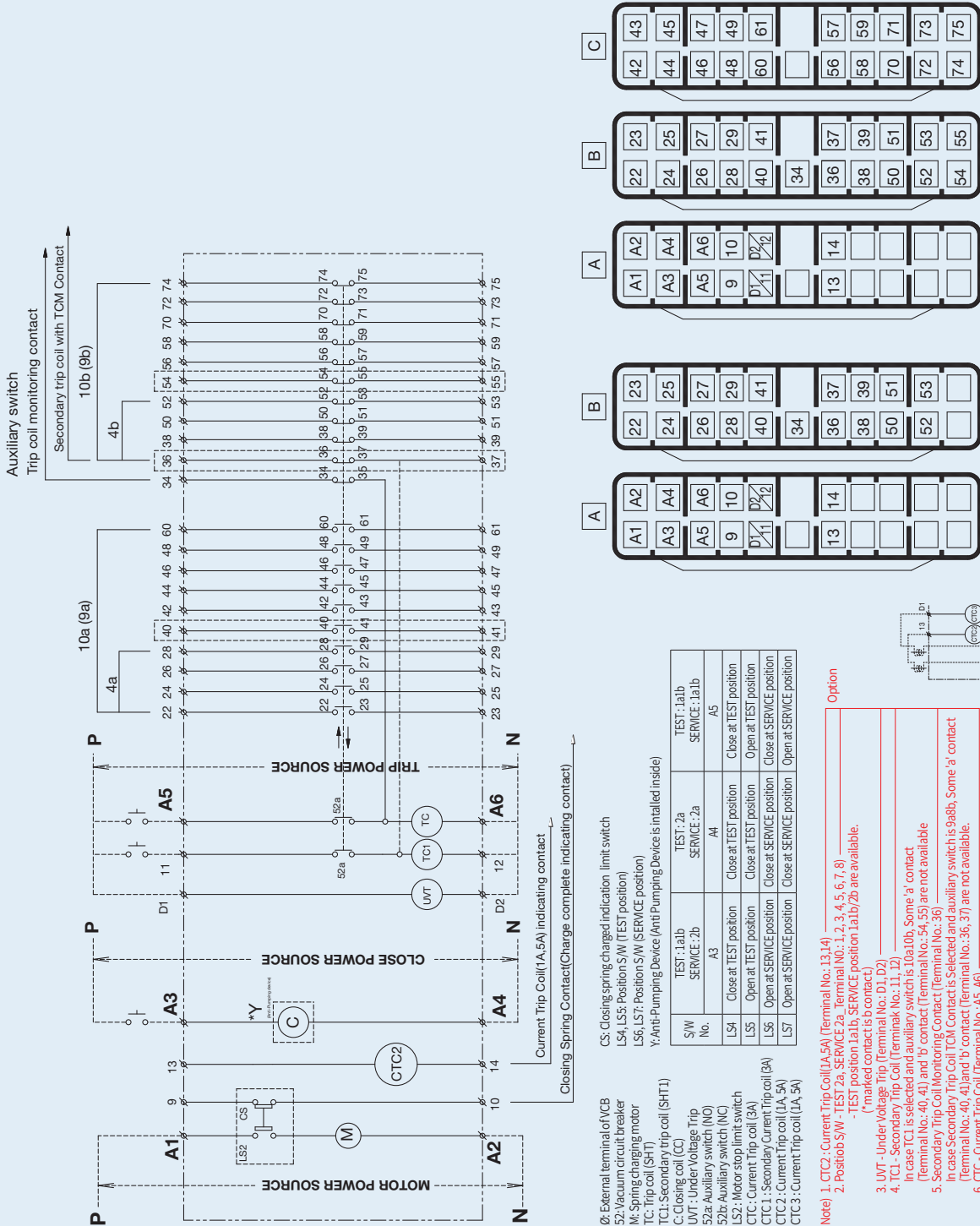

<Connector Terminal Configuration>
(10a10b)
(4a4b)

S/W No.	TEST: 1a1b	SERVICE: 2a	TEST: 2a	SERVICE: 2a
LS4	A3	A4	A4	A5
LS5	Close at TEST position	Close at TEST position	Close at TEST position	Open at TEST position
LS6	Open at TEST position	Open at TEST position	Close at TEST position	Close at TEST position
LS7	Open at SERVICE position	Open at SERVICE position	Close at SERVICE position	Open at SERVICE position

- Note 1. CTC2 - Current Trip Coil (LA, 5A) (Terminal No.: 13, 14)
 2. Positrob S/W - TEST 2a, SERVICE 2a, Terminal No.: 1, 2, 3, 4, 5, 6, 7, 8
 - TEST position 1a1b, SERVICE position 1a1b/2b are available.
 (* marked contact is b contact)
3. UVT - Under Voltage Trip (Terminal No.: D1, D2)
 4. TC1 - Secondary Trip Coil (Terminal No.: 11, 12)
 In case TC1 is selected and auxiliary switch is 10a10b, Some 'a' contact (Terminal No.: 40, 41) and 'b' contact (Terminal No.: 54, 55) are not available
5. Secondary Trip coil Monitoring Contact (Terminal No.: 36)
 In case Secondary Trip Coil TCM Contact is Selected and auxiliary switch is 9a8b, Some 'a' contact (Terminal No.: 40, 41) and 'b' contact (Terminal No.: 36, 37) are not available.
6. CTC - Current Trip Coil (Terminal No.: A5, A6)
 CTC1 - Secondary Current Trip Coil (Terminal No.: 11, 12)
 CTC2 - Current Trip Coil (Terminal No.: 13, 14)
 CTC3 - Current Trip Coil (Terminal No.: D1, D2)
7. Close and Trip coil is One Pulse type, excluding Trip coil (DC24, DC48, DC110, 220V)
 8. In above optional accessories, UVT, CTC and TC1, can not be selected simultaneously.
 9. Above circuit diagram is based on "OFF" state of VCB and closing spring is charged.

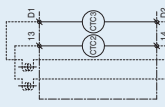

10. CTC Control Circuit

Circuit diagram for VCB control in remote

UVM-05/15

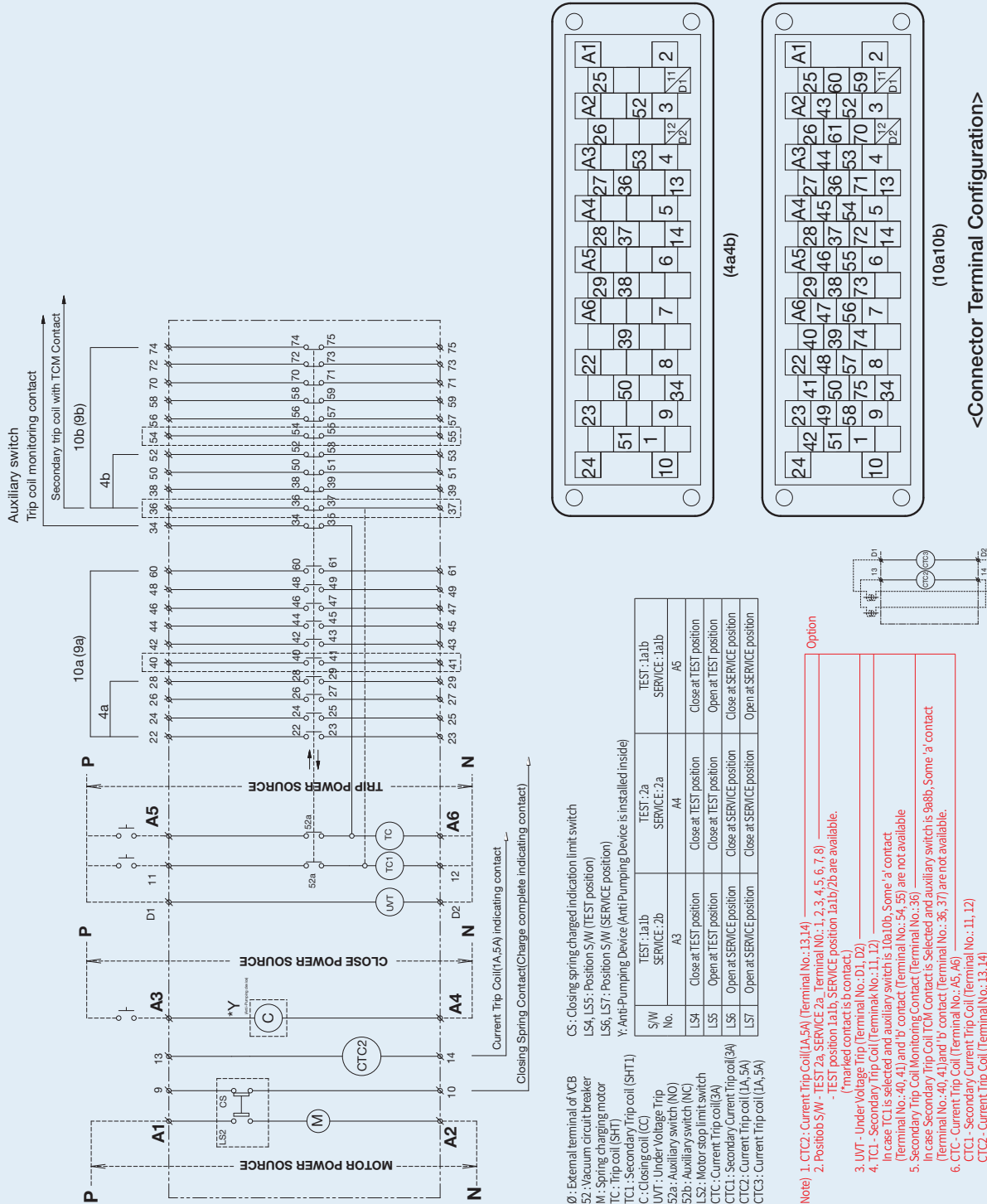

UVH-05/15/27

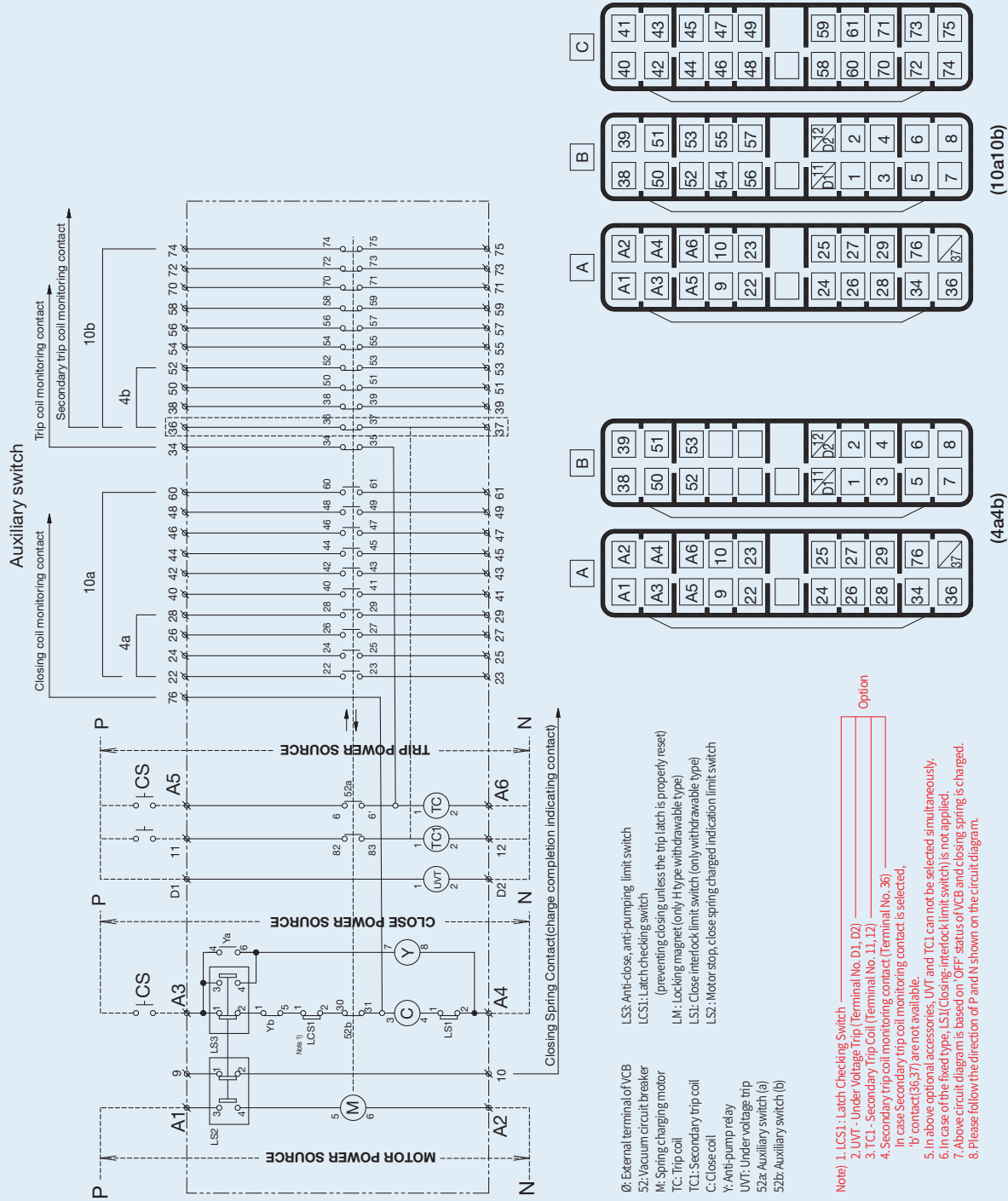

<Connector Terminal Configuration>

Circuit diagram for VCB control in remote

UVH-05/15/27

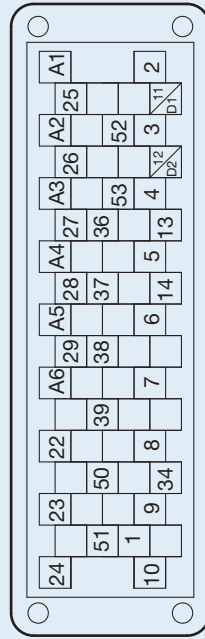
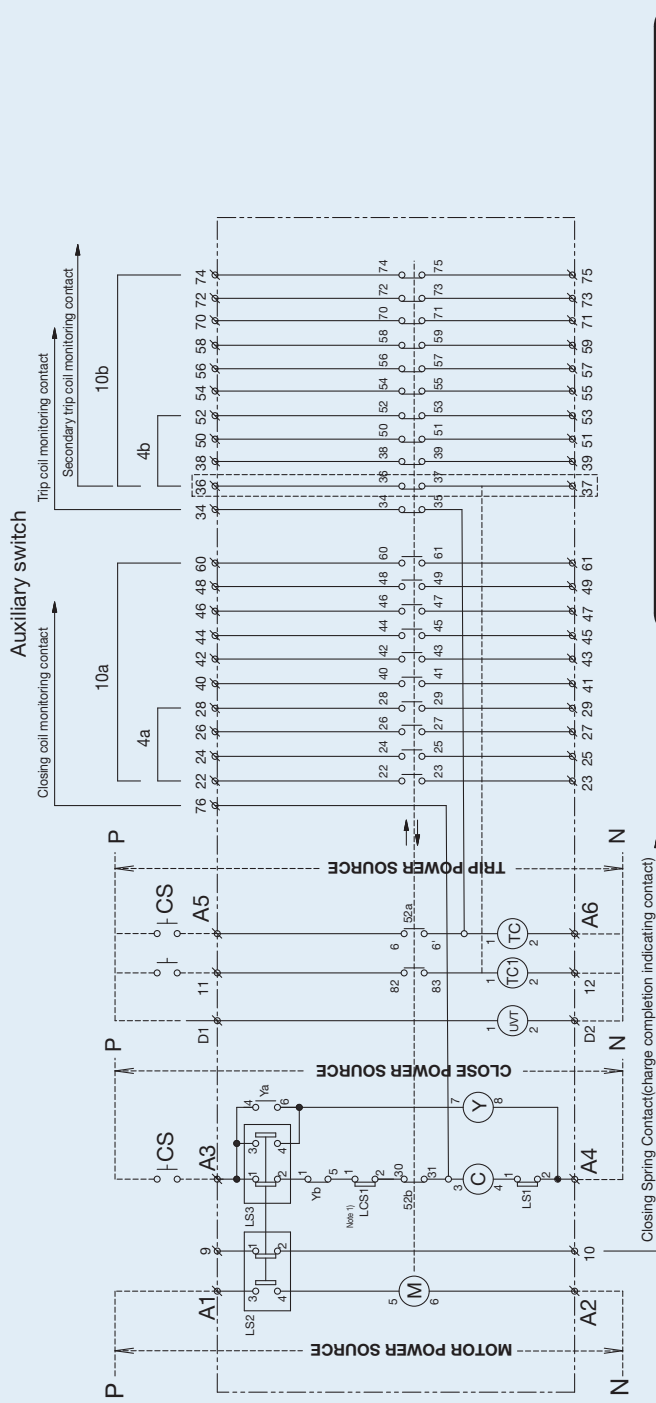

(4a4b)

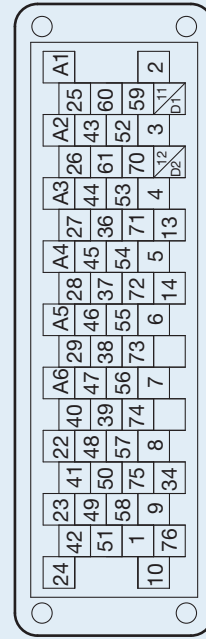

(10a10b)

<Connector Terminal Configuration>

- Ø: External terminal of VCB
- 52: Vacuum circuit breaker
- M: Spring charging motor
- TC: Trip coil
- TC1: Secondary trip coil
- C: Close coil
- Y: Anti-pump relay
- LWT: Under voltage trip
- 52a: Auxiliary switch (a)
- 52b: Auxiliary switch (b)
- LSC3: Anti-close, anti-pumping limit switch
- LCS1: Latch checking switch (preventing closing unless the trip latch is properly reset)
- LM: Locking magnet (only H type withdrawable type)
- LS1: Close interlock limit switch (only withdrawable type)
- LS2: Motor stop, close spring charged indication limit switch

- Note) 1. LCS1: Latch Checking Switch
2. LWT - Under Voltage Trip (Terminal No. D1, D2) Option
3. TC1 - Secondary Trip Coil (Terminal No. 11, 12)
4. Secondary trip coil monitoring contact (Terminal No. 36) Option
- In case secondary trip coil monitoring contact is selected, 'b' contact (36/37) are not available.
5. In above optional accessories, LWT and TC1 can not be selected simultaneously.
6. In case of the fixed type, LS1 (Closing interlock limit switch) is not applied.
7. Above circuit diagram is based on 'OFF' status of VCB and closing spring is charged.
8. Please follow the direction of P and N shown on the circuit diagram.

UVH-38

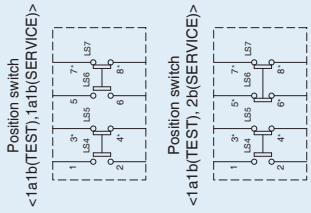
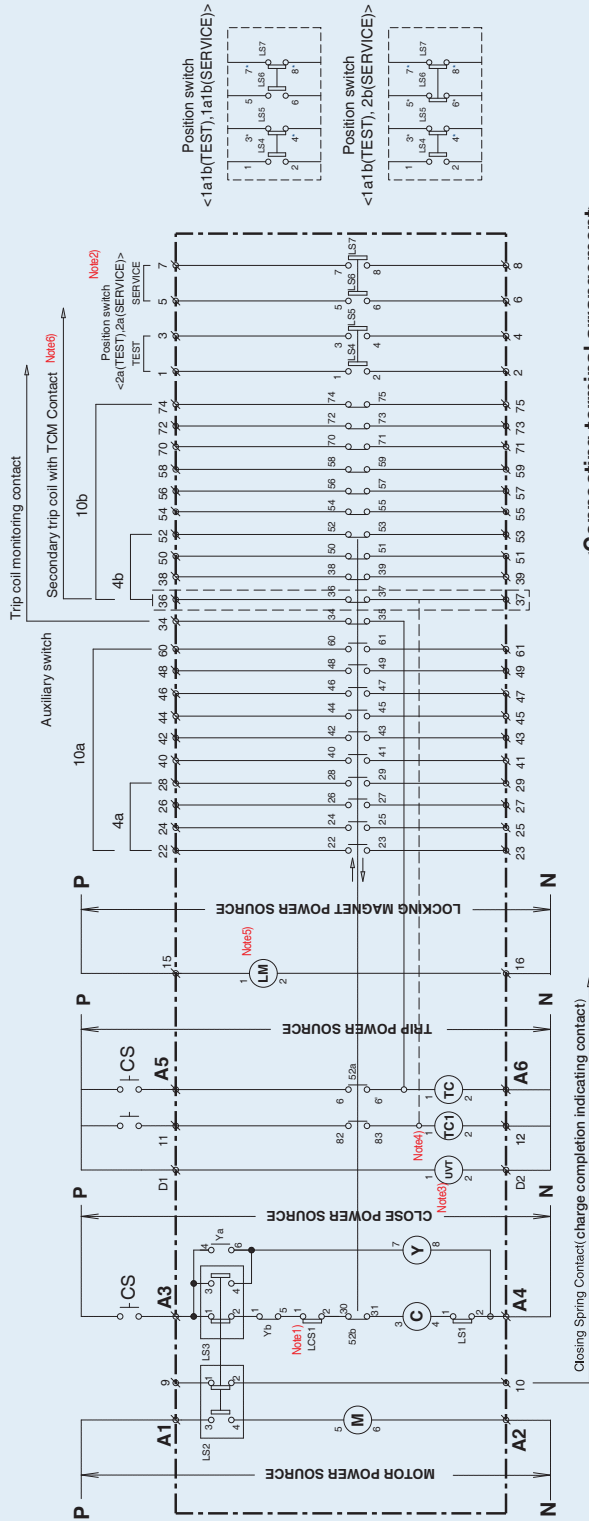

<Connecting terminal arrangement>

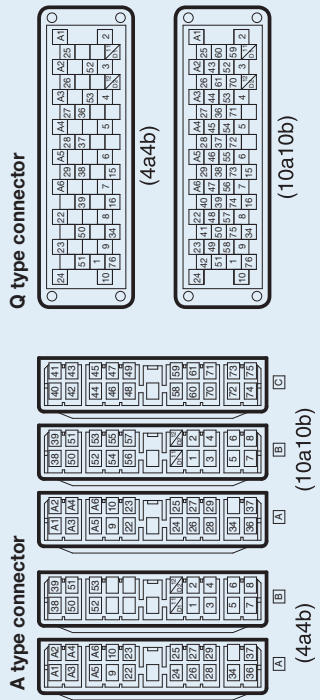

SW No.	TEST: .1a1b SERVICE: .2a	TEST: .1a1b SERVICE: .1a1b
LS4	Close at TEST position	Close at TEST position
LS5	OPEN at TEST position	OPEN at TEST position
LS6	OPEN at SERVICE position	Close at SERVICE position
LS7	OPEN at SERVICE position	OPEN at SERVICE position

0: External terminal of MCB
 LS3: Anti-close, anti-pumping limit switch
 LCS1: Trip latch checking switch (preventing closing unless the trip latch is properly reset)
 M: Spring charging motor
 TC: Trip coil
 TC1: Secondary trip coil
 C: Close coil
 Y: Anti-pump relay
 UVT: Under voltage trip
 52a: Auxiliary switch (a)
 52b: Auxiliary switch (b)
 LS1: Close interlock limit switch (only withdrawable type)
 LS2: Motor stop, close spring changed indication limit switch LM: Locking magnet (only withdrawable type)

- Note)**
- LCS1: Latch Checking Switch
 - Position SW - TEST 2a, SERVICE 2a(Terminal No. 1, 2, 3, 4, 5, 6, 7, 8) .1a1b at TEST position and .1a1b at SERVICE position are also available. (In case of .1a1b "marked contact is b - normally open contact)
 - UVT - Under voltage trip (Terminal No. D1, D2)
 - TC1 - Secondary Trip Coil (Terminal No. 11, 12)
 - LM - Locking Magnet (Terminal No. 15, 16). Type H only withdrawable type.
 - Secondary Trip Coil monitoring contact (Terminal No. 36) b contact(36, 37) is not available if Trip Coil monitoring contact is applied to Secondary Trip Coil.
 - Above options TC1 and UVT can not be used simultaneously.
 - LS1(closing-merlock Limit-switch) is not available for fixed version
 - Above circuit diagram is based on "OFF" status of VC B and closing spring is charged.
 - Please make sure that keep the direction of P, N on this circuit diagram.

Technical data

Specification

UVL-Type (4.76kV)

Designation			UVL type			
			UVL-05□25□12	UVL-05□52□20	UVL-05□32□12	UVL-05□32□20
Rated voltage	Ur (kV)		4.76			
Rated current	Ir (A)		1200	2000	1200	2000
Pole distance	(mm)		5.9" (150mm) / 8.27" (210mm)	8.27" (210mm)	5.9" (150mm) / 8.27" (210mm)	8.27" (210mm)
Rated frequency	fr (Hz)		60			
Rated interrupting current	Ik (kA)		25		31.5	
Rated interrupting capacity	(MVA)		203		260	
Rated short-time current	Ik/tk (kA)		25 / 3s		31.5 / 3s	
Rated making current	Ip (kA)		65		81.9	
Rated interrupting time	(cycle)		3			
Withstand Voltage	Frequency	Ud (kV)	19			
	Impulse	Up (kV/1.2×50μs)	60			
Operating duty			O-0.3s-CO-15s-CO			
Motor	Control voltage	(V)	DC24~30V, DC48~60V, DC110V, DC125V, DC200~250V, AC48V, AC110~130V, AC200~250V			
Closing coil	Control voltage	(V)	DC24~30V, DC48~60V, DC110V, DC125V, DC200~250V, AC48V, AC110~130V, AC200~250V			
Trip coil	Control voltage	(V)	DC24~30V, DC48~60V, DC110V, DC125V, DC200~250V, AC48V, AC110~130V, AC200~250V			
UVT coil	Control voltage	(V)	DC24~30V, DC48~60V, DC110V, DC125V, DC200~250V, AC48V, AC110~130V, AC200~250V			
Standard aux. contacts	Type		4a4b, 10a10b			
	Rated Continuous current		DC 10A			
	Baeaking capacity		600W			
	Endurance (Operations) (Mechanical, Interrupting)		10000 times			
Rated opening time	(S)		≤ 0.04			
No-load closing time	(S)		≤ 0.06			
Mechanical endurance	(Operations)		M2 (10000 times)			
VI(Vacuum interrupter) type			LV6	LV6A	LV6	LV6A
Electrical endurance			Reference standard			
Capacitive current switching			C2			
Operate temperature	Low		-40°C			
	High		40°C			
Life time	Electrical	(Operations)	Reference electrical life graph			
Installation	Fixed		H, P type			
Applicable standard			IEEE Std C37.09, ANSI C37.54			
UL Certificate			UL Listed			

UVL-Type (15kV)

Designation			UVL type			
			UVL-15□25□12	UVL-15□25□20	UVL-15□32□12	UVL-15□32□20
Rated voltage	Ur (kV)	15				
Rated current	Ir (A)	1200	2000	1200	2000	
Pole distance	(mm)	5.9" (150mm) / 8.27" (210mm)	8.27" (210mm)	5.9" (150mm) / 8.27" (210mm)	8.27" (210mm)	
Rated frequency	fr (Hz)	60				
Rated interrupting current	Ik (kA)	25		31.5		
Rated interrupting capacity	(MVA)	650		820		
Rated short-time current	Ik/tk (kA)	25 / 3s		31.5 / 3s		
Rated making current	Ip (kA)	65		81.9		
Rated interrupting time	(cycle)	3				
Withstand Voltage	Frequency	Ud (kV)	36			
	Impulse	Up (kV/1.2×50μs)	95			
Operating duty			O-0.3s-CO-15s-CO			
Motor	Control voltage	(V)	DC24~30V, DC48~60V, DC110V, DC125V, DC200~250V, AC48V, AC110~130V, AC200~250V			
Closing coil	Control voltage	(V)	DC24~30V, DC48~60V, DC110V, DC125V, DC200~250V, AC48V, AC110~130V, AC200~250V			
Trip coil	Control voltage	(V)	DC24~30V, DC48~60V, DC110V, DC125V, DC200~250V, AC48V, AC110~130V, AC200~250V			
UVT coil	Control voltage	(V)	DC24~30V, DC48~60V, DC110V, DC125V, DC200~250V, AC48V, AC110~130V, AC200~250V			
Standard aux. contacts	Type		4a4b, 10a10b			
	Rated Continuous current		DC 10A			
	Baeaking capacity		600W			
	Endurance (Operations) (Mechanical, Interrupting)		10000 times			
Rated opening time	(S)	≤ 0.04				
No-load closing time	(S)	≤ 0.06				
Mechanical endurance	(Operations)	M2 (10000 times)				
VI(Vacuum interrupter) type		LV6	LV6A	LV6	LV6A	
Electrical endurance			Reference standard			
Capacitive current switching			C2			
Operate temperature	Low	-40°C				
	High	40°C				
Life time	Electrical	(Operations)	Reference electrical life graph			
Installation	Fixed	H, P type				
Applicable standard			IEEE Std C37.09, ANSI C37.54			
UL Certificate			UL Listed			

Technical data

Specification

UVL-Type (27kV)

Designation			UVL type
			UVL-27P32C20
Rated voltage	Ur (kV)		27
Rated current	Ir (A)		1200
Pole distance	(mm)		10" (254mm)
Rated frequency	fr (Hz)		60
Rated interrupting current	Ik (kA)		25
Rated interrupting capacity	(MVA)		1170
Rated short-time current	Ik/tk (kA)		25 / 3s
Rated making current	Ip (kA)		65
Rated interrupting time	(cycle)		3
Withstand Voltage	Frequency	Ud (kV)	60
	Impulse	Up (kV/1.2×50μs)	125
Operating duty			O-0.3s-CO-15s-CO
Motor	Control voltage	(V)	DC24~30V, DC48~60V, DC110V, DC125V, DC200~250V, AC48V, AC110~130V, AC200~250V
Closing coil	Control voltage	(V)	DC24~30V, DC48~60V, DC110V, DC125V, DC200~250V, AC48V, AC110~130V, AC200~250V
Trip coil	Control voltage	(V)	DC24~30V, DC48~60V, DC110V, DC125V, DC200~250V, AC48V, AC110~130V, AC200~250V
UVT coil	Control voltage	(V)	DC24~30V, DC48~60V, DC110V, DC125V, DC200~250V, AC48V, AC110~130V, AC200~250V
Standard aux. contacts	Type		4a4b, 10a10b
	Rated Continuous current		DC 10A
	Baeaking capacity		600W
	Endurance (Operations) (Mechanical, Interrupting)		10000 times
Rated opening time		(S)	≤ 0.04
No-load closing time		(S)	≤ 0.07
Mechanical endurance		(Operations)	M2 (10000 times)
VI(Vacuum interrupter) type			LV14-P1
Electrical endurance			Reference standard
Capacitive current switching			C2
Operate temperature	Low		-40°C
	High		40°C
Life time	Electrical	(Operations)	Reference electrical life graph
Installation	Fixed		P type
Applicable standard			IEEE Std C37.09
UL Certificate			ANSI type test

UVM-Type (4.76kV)

Designation			UVM type			
			UVM-05□25□12	UVM-05□52□20	UVM-05□32□12	UVM-05□32□20
Rated voltage	Ur (kV)	4.76				
Rated current	Ir (A)	1200	2000	1200	2000	
Pole distance	(mm)	7" (178mm) / 10" (254mm)				
Rated frequency	fr (Hz)	60				
Rated interrupting current	Ik (kA)	25		31.5		
Rated interrupting capacity	(MVA)	206		260		
Rated short-time current	Ik/tk (kA)	25 / 3s		31.5 / 3s		
Rated making current	Ip (kA)	65		81.9		
Rated interrupting time	(cycle)	3				
Withstand Voltage	Frequency	Ud (kV)	19			
	Impulse	Up (kV/1.2×50μs)	60			
Operating duty	O-0.3s-CO-15s-CO					
Motor	Control voltage	(V)	DC24~30V, DC48~60V, DC110V, DC125V, DC200~250V, AC48V, AC110~130V, AC200~250V			
Closing coil	Control voltage	(V)	DC24~30V, DC48~60V, DC110V, DC125V, DC200~250V, AC48V, AC110~130V, AC200~250V			
Trip coil	Control voltage	(V)	DC24~30V, DC48~60V, DC110V, DC125V, DC200~250V, AC48V, AC110~130V, AC200~250V			
UVT coil	Control voltage	(V)	DC24~30V, DC48~60V, DC110V, DC125V, DC200~250V, AC48V, AC110~130V, AC200~250V			
Standard aux. contacts	Type	4a4b, 10a10b				
	Rated Continuous current	DC 10A				
	Baeaking capacity	600W				
	Endurance (Operations) (Mechanical, Interrupting)	10000 times				
Rated opening time	(S)	≤ 0.04				
No-load closing time	(S)	≤ 0.06				
Mechanical endurance	(Operations)	M2 (10000 times)				
VI(Vacuum interrupter) type		LV5	LV6A	LV6	LV6A	
Electrical endurance	Reference standard					
Capacitive current switching	C2					
Operate temperature	Low	-40°C				
	High	40°C				
Life time	Electrical	(Operations)	Reference electrical life graph			
Installation	Fixed	H, P type				
Applicable standard	IEEE Std C37.09, ANSI C37.54					
UL Certificate	UL Listed					

Technical data

Specification

UVM-Type (15kV)

Designation			UVM type			
			UVM-15□25□12	UVM-15□25□20	UVM-15□32□12	UVM-15□32□20
Rated voltage	Ur (kV)	15				
Rated current	Ir (A)	1200	2000	1200	2000	
Pole distance	(mm)	7" (178mm) / 10" (254mm)				
Rated frequency	fr (Hz)	60				
Rated interrupting current	Ik (kA)	25		31.5		
Rated interrupting capacity	(MVA)	650		820		
Rated short-time current	Ik/tk (kA)	25 / 3s		31.5 / 3s		
Rated making current	Ip (kA)	65		81.9		
Rated interrupting time	(cycle)	3				
Withstand Voltage	Frequency	Ud (kV)	36			
	Impulse	Up (kV/1.2×50μs)	95			
Operating duty		O-0.3s-CO-15s-CO				
Motor	Control voltage	(V)	DC24~30V, DC48~60V, DC110V, DC125V, DC200~250V, AC48V, AC110~130V, AC200~250V			
Closing coil	Control voltage	(V)	DC24~30V, DC48~60V, DC110V, DC125V, DC200~250V, AC48V, AC110~130V, AC200~250V			
Trip coil	Control voltage	(V)	DC24~30V, DC48~60V, DC110V, DC125V, DC200~250V, AC48V, AC110~130V, AC200~250V			
UVT coil	Control voltage	(V)	DC24~30V, DC48~60V, DC110V, DC125V, DC200~250V, AC48V, AC110~130V, AC200~250V			
Standard aux. contacts	Type		4a4b, 10a10b			
	Rated Continuous current		DC 10A			
	Baeaking capacity		600W			
	Endurance (Operations) (Mechanical, Interrupting)		10000 times			
Rated opening time	(S)	≤ 0.04				
No-load closing time	(S)	≤ 0.06				
Mechanical endurance	(Operations)	M2 (10000 times)				
VI(Vacuum interrupter) type		LV5	LV6A	LV6	LV6A	
Electrical endurance		Reference standard				
Capacitive current switching		C2				
Operate temperature	Low	-40°C				
	High	40°C				
Life time	Electrical	(Operations)	Reference electrical life graph			
Installation	Fixed		H, P type			
Applicable standard		IEEE Std C37.09, ANSI C37.54				
UL Certificate		UL Listed				

UVH-Type (4.76kV)

Designation			UVH type					
			UVH-05□40□12	UVH-05□40□20	UVH-05□50□12	UVH-05□50□20	UVH-05□25,32,40,50□30	UVH-05□25,32,40,50□40
Rated voltage	Ur (kV)		4.76					
Rated current	Ir (A)		1200	2000	1200	2000	3000	4000
Pole distance	(mm)		7" (178mm) / 10" (254mm)			10" (254mm)	12.6" (320mm)	
Rated frequency	fr (Hz)		60					
Rated interrupting current	Ik (kA)		40		50		25 / 31.5 / 40 / 50	
Rated interrupting capacity	(MVA)		330		410		206 / 260 / 330 / 410	
Rated short-time current	Ik/tk (kA)		25 / 3s		31.5 / 3s		25 / 3s, 31.5 / 3s, 40 / 3s, 50 / 3s	
Rated making current	Ip (kA)		104		130		65 / 81.9 / 104 / 130	
Rated interrupting time	(cycle)		3					
Withstand Voltage	Frequency	Ud (kV)	19					
	Impulse	Up (kV/1.2×50μs)	60					
Operating duty			O-0.3s-CO-15s-CO					
Motor	Control voltage	(V)	DC48~60V, DC110V, DC125V, DC200~250V, AC48V, AC110~130V, AC200~250V					
Closing coil	Control voltage	(V)	DC48~60V, DC110V, DC125V, DC200~250V, AC48V, AC110~130V, AC200~250V					
Trip coil	Control voltage	(V)	DC48~60V, DC110V, DC125V, DC200~250V, AC48V, AC110~130V, AC200~250V					
UVT coil	Control voltage	(V)	DC48~60V, DC110V, DC125V, DC200~250V, AC48V, AC110~130V, AC200~250V					
Standard aux. contacts	Type		4a4b, 10a10b					
	Rated Continuous current		DC 10A					
	Baeaking capacity		600W					
	Endurance (Operations) (Mechanical, Interrupting)		10000 times					
Rated opening time	(S)		≤ 0.04					
No-load closing time	(S)		≤ 0.06					
Mechanical endurance	(Operations)		M2 (10000 times)					
VI(Vacuum interrupter) type			LV10	LV8		LV8	LV8	
Electrical endurance			Reference standard					
Capacitive current switching			C2					
Operate temperature	Low		-40°C					
	High		40°C					
Life time	Electrical	(Operations)	Reference electrical life graph					
Installation	Fixed		H, P type					
Applicable standard			IEEE Std C37.09, ANSI C37.54					
UL Certificate			UL Listed					

Technical data

Specification

UVH-Type (15kV)

Designation			UVH type					
			UVH-15□40□12	UVH-15□40□20	UVH-15□50□12	UVH-15□50□20	UVH-15□25,32,40,50□30	UVH-15□25,32,40,50□40
Rated voltage	Ur (kV)		15					
Rated current	Ir (A)		1200	2000	1200	2000	3000	4000
Pole distance	(mm)		7" (178mm) / 10" (254mm)			10" (254mm)	12.6" (320mm)	
Rated frequency	fr (Hz)		60					
Rated interrupting current	Ik (kA)		40		50		25 / 31.5 / 40 / 50	25 / 31.5 / 40 / 50
Rated interrupting capacity	(MVA)		1040		1300		650/820/1040/1300	650/820/1040/1300
Rated short-time current	Ik/tk (kA)		25 / 3s		31.5 / 3s		25 / 3s, 31.5 / 3s, 40 / 3s, 50 / 3s	25 / 3s, 31.5 / 3s, 40 / 3s, 50 / 3s
Rated making current	Ip (kA)		104		130		65 / 81.9 / 104 / 130	65 / 81.9 / 104 / 130
Rated interrupting time	(cycle)		3					
Withstand Voltage	Frequency	Ud (kV)	36					
	Impulse	Up (kV/1.2×50μs)	95					
Operating duty			O-0.3s-CO-15s-CO					
Motor	Control voltage	(V)	DC48~60V, DC110V, DC125V, DC200~250V, AC48V, AC110~130V, AC200~250V					
Closing coil	Control voltage	(V)	DC48~60V, DC110V, DC125V, DC200~250V, AC48V, AC110~130V, AC200~250V					
Trip coil	Control voltage	(V)	DC48~60V, DC110V, DC125V, DC200~250V, AC48V, AC110~130V, AC200~250V					
UVT coil	Control voltage	(V)	DC48~60V, DC110V, DC125V, DC200~250V, AC48V, AC110~130V, AC200~250V					
Standard aux. contacts	Type		4a4b, 10a10b					
	Rated Continuous current		DC 10A					
	Baeaking capacity		600W					
	Endurance (Operations) (Mechanical, Interrupting)		10000 times					
Rated opening time	(S)		≤ 0.04					
No-load closing time	(S)		≤ 0.06					
Mechanical endurance	(Operations)		M2 (10000 times)					
VI(Vacuum interrupter) type			LV10		LV8		LV8	LV8
Electrical endurance			Reference standard					
Capacitive current switching			C2					
Operate temperature	Low		-40°C					
	High		40°C					
Life time	Electrical	(Operations)	Reference electrical life graph					
Installation	Fixed		H, P type					
Applicable standard			IEEE Std C37.09, ANSI C37.54					
UL Certificate			UL Listed					

UVH-Type (27kV)

Designation			UVH type					
			UVH-27□25C25	UVH-27□25C28	UVH-27□32,40C12	UVH-27□32,40C20	UVH-27□32,40C25	UVH-27□32,40C28
Rated voltage	Ur (kV)		27					
Rated current	Ir (A)		2500	2750	1200	2000	2500	2750
Pole distance	(mm)		10" (254mm) 10" (254mm)					
Rated frequency	fr (Hz)		60					
Rated interrupting current	Ik (kA)		25		31.5/40			
Rated interrupting capacity	(MVA)		1169		1473/1871			
Rated short-time current	Ik/tk (kA)		25/3s		31.5/3s, 40/3s			
Rated making current	Ip (kA)		65		81.9/104			
Rated interrupting time	(cycle)		3					
Withstand Voltage	Frequency	Ud (kV)	60					
	Impulse	Up (kV/1.2×50μs)	125					
Operating duty			O-0.3s-CO-15s-CO					
Motor	Control voltage	(V)	DC48~60V, DC110V, DC125V, DC200~250V, AC48V, AC110~130V, AC200~250V					
Closing coil	Control voltage	(V)	DC48~60V, DC110V, DC125V, DC200~250V, AC48V, AC110~130V, AC200~250V					
Trip coil	Control voltage	(V)	DC48~60V, DC110V, DC125V, DC200~250V, AC48V, AC110~130V, AC200~250V					
UVT coil	Control voltage	(V)	DC48~60V, DC110V, DC125V, DC200~250V, AC48V, AC110~130V, AC200~250V					
Standard aux. contacts	Type		4a4b, 10a10b					
	Rated Continuous current		DC 10A					
	Baeaking capacity		600W					
	Endurance (Operations) (Mechanical, Interrupting)		10000 times					
Rated opening time	(S)		≤ 0.04					
No-load closing time	(S)		≤ 0.06					
Mechanical endurance	(Operations)		M2 (10000 times)					
VI(Vacuum interrupter) type			LV7-P1					
Electrical endurance			Reference standard					
Capacitive current switching			C2					
Operate temperature	Low		-40°C					
	High		40°C					
Life time	Electrical	(Operations)	Reference electrical life graph					
Installation	Fixed		H, P type					
Applicable standard			IEEE Std C37.09, ANSI C37.54					
UL Certificate			UL Listed					

Technical data

Specification

UVH-Type (38kV)

Designation			UVH type	
			UVH-38□32,40E12	UVH-38□32,40E20
Rated voltage	Ur (kV)		38	
Rated current	Ir (A)	1200	2000	
Pole distance	(mm)	11.8" (300mm)		
Rated frequency	fr (Hz)	60		
Rated interrupting current	Ik (kA)	31.5 / 40		
Rated interrupting capacity	(MVA)	2074 / 2633		
Rated short-time current	Ik/tk (kA)	31.5 / 3s, 40 / 3s		
Rated making current	Ip (kA)	81.9 / 104		
Rated interrupting time	(cycle)	3		
Withstand Voltage	Frequency	Ud (kV)	80	
	Impulse	Up (kV/1.2×50μs)	170	
Operating duty			O-0.3s-CO-15s-CO	
Motor	Control voltage	(V)	DC48~60V, DC110V, DC125V, DC200~250V, AC48V, AC110~130V, AC200~250V	
Closing coil	Control voltage	(V)	DC48~60V, DC110V, DC125V, DC200~250V, AC48V, AC110~130V, AC200~250V	
Trip coil	Control voltage	(V)	DC48~60V, DC110V, DC125V, DC200~250V, AC48V, AC110~130V, AC200~250V	
UVT coil	Control voltage	(V)	DC48~60V, DC110V, DC125V, DC200~250V, AC48V, AC110~130V, AC200~250V	
Standard aux. contacts	Type		4a4b, 10a10b	
	Rated Continuous current		DC 10A	
	Baeaking capacity		600W	
	Endurance (Operations) (Mechanical, Interrupting)		10000 times	
Rated opening time	(S)		≤ 0.04	
No-load closing time	(S)		≤ 0.06	
Mechanical endurance	(Operations)		M2 (10000 times)	
VI(Vacuum interrupter) type			LV8-P	
Electrical endurance			Reference standard	
Capacitive current switching			C2	
Operate temperature	Low		-40°C	
	High		40°C	
Life time	Electrical	(Operations)	Reference electrical life graph	
Installation	Fixed		H, P type	
Applicable standard			IEEE Std C37.09	
UL Certificate			ANSI type test	

Electrical endurance by interrupting current

Rated voltage		4.76kV				15kV				27kV			38kV	
Ir [A]	Isc [kA]	25	31.5	40	50	25	31.5	40	50	25	31.5	40	31.5	40
	1200		LV5(UVM) LV6(UVL)	LV6 (UVL, UVM)	LV10 (UVH)	LV8 (UVH)	LV5(UVM) LV6(UVL)	LV6 (UVL, UVM)	LV10 (UVH)	LV8 (UVH)	LV14-P1 (UVL)	LV7-P1 (UVH)	LV7-P1 (UVH)	LV8 (UVH)
2000		LV5(UVM) LV6(UVL)	LV6 (UVL, UVM)	LV10 (UVH)	LV8 (UVH)	LV5(UVM) LV6(UVL)	LV6 (UVL, UVM)	LV10 (UVH)	LV8 (UVH)		LV7-P1 (UVH)	LV7-P1 (UVH)	LV8 (UVH)	LV8 (UVH)
2500										LV7-P1 (UVH)	LV7-P1 (UVH)	LV7-P1 (UVH)		
2750										LV7-P1 (UVH)	LV7-P1 (UVH)	LV7-P1 (UVH)		
3000		LV8 (UVH)	LV8 (UVH)	LV8 (UVH)	LV8 (UVH)	LV8 (UVH)	LV8 (UVH)	LV8 (UVH)	LV8 (UVH)					
4000		LV8 (UVH)	LV8 (UVH)	LV8 (UVH)	LV8 (UVH)	LV8 (UVH)	LV8 (UVH)	LV8 (UVH)	LV8 (UVH)					

- : UVL/UVM-05/15 UL certified
- : UVL-27 ANSI type test
- : UVH-05/15 UL certified
- : UVH-27 UL certified
- : UVH-38 ANSI type test
- : Not developed

VI Model	Page	VI Model	Page
LV5	201	LV8	202
LV6	201	LV10	202
LV7-P1	202	LV14-P1	202

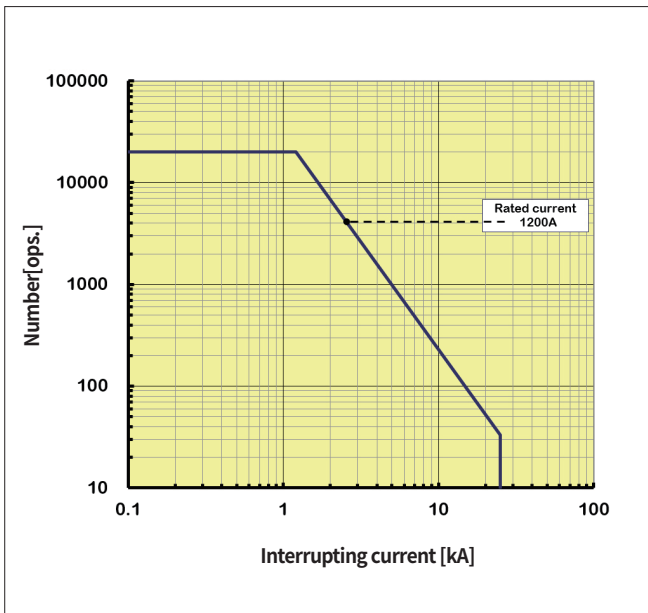

VI Model : LV5

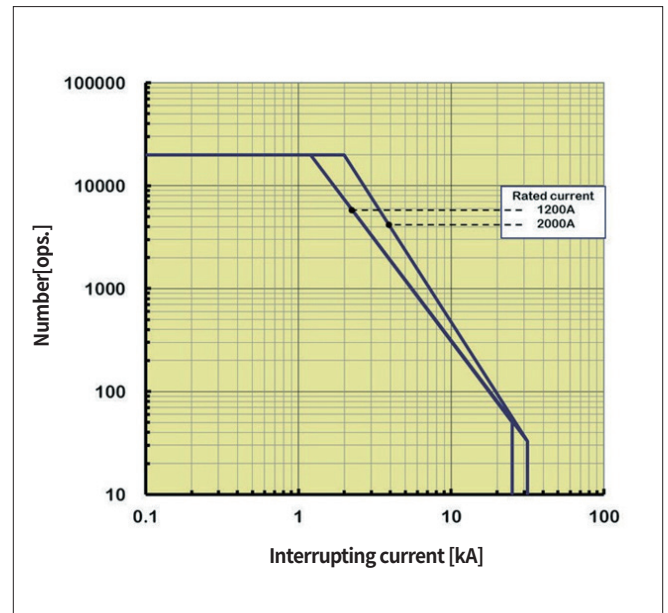

VI Model : LV6

Note) 1. Above graphs represent the characteristics of the electrical life of LS Susol VCB.
 2. Life characteristics of each model in each rating represents the LOG-LOG graphs.

Technical data

Electrical endurance by interrupting current

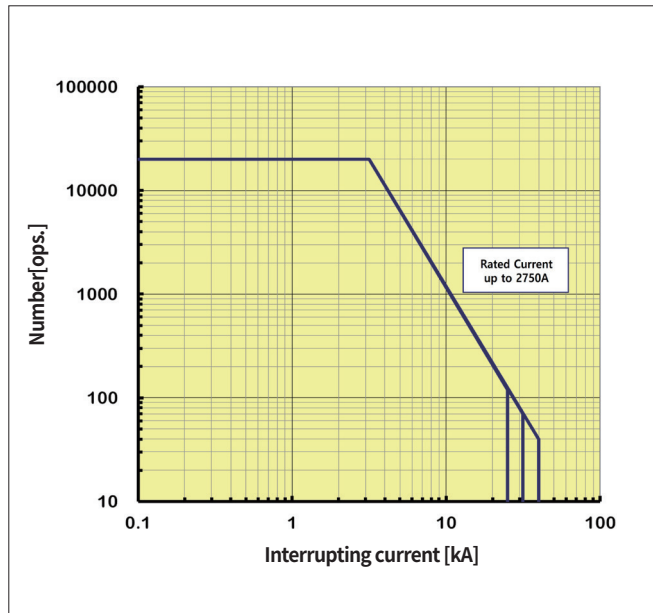

VI Model : LV7-P1

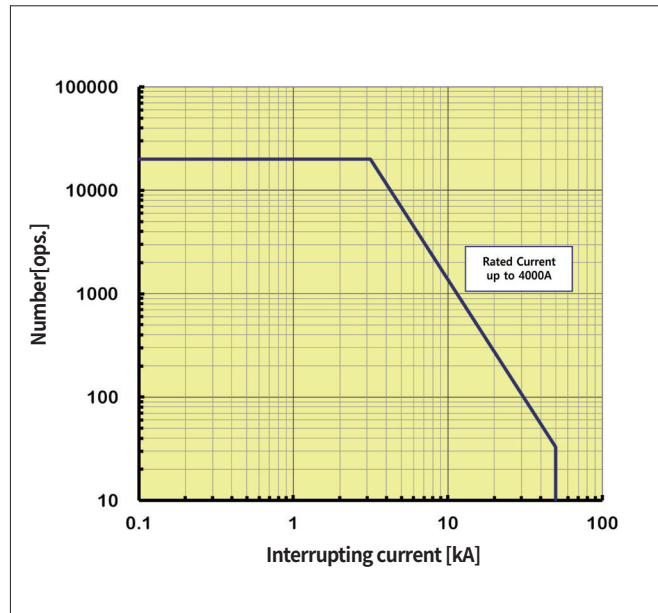

VI Model : LV8

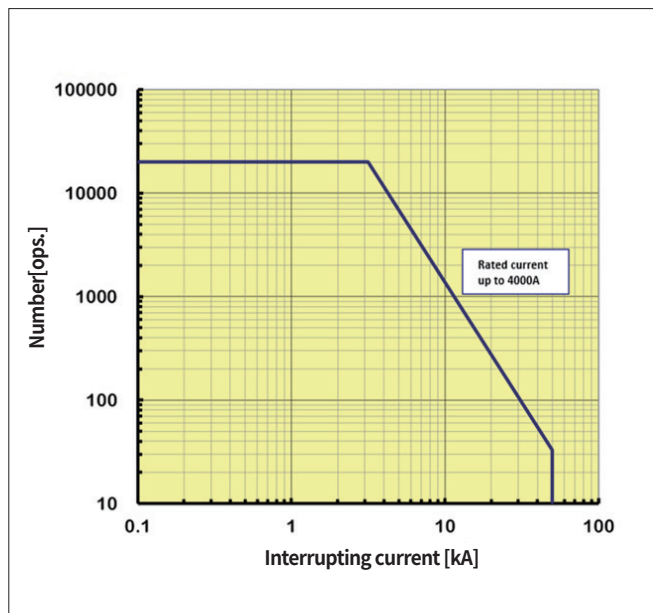

VI Model : LV10

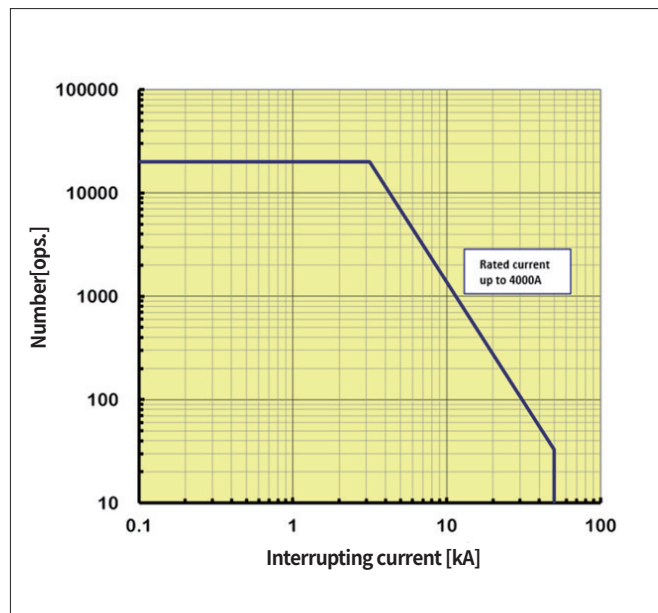

VI Model : LV14-P1

Note) 1. Above graphs represent the characteristics of the electrical life of LS Susol VCB.
2. Life characteristics of each model in each rating represents the LOG-LOG graphs.

Basic functions

Manual operation

① Manual Charge

- UVM type: operate the charge handle 7-8 times as a fully stroke.
- UVH type: Insert the charge handle into the handle slot first. Rotate the handle clockwise 40 times more and then charge will be complete with a click sound.
- When the closing spring is charged fully "CHARGED" is displayed at the charge indicator.

② Manual closing

- Pressing the CLOSE Button the breaker is closed.
- With the closing of the breaker "CLOSE" is displayed at CLOSED/OPEN Indicator and "DISCHARGED" at the charge indicator.

③ Manual trip

- Pressing the OPEN Button the breaker is opened.
- "OPEN" is displayed at CLOSED/OPEN Indicator.

Electric operation

① Electric charge

The breaker is remotely closing with charging of closing spring.
If the breaker trips the closing spring is automatically charged by gear motors.

② Electric closing

Remote closing is operated by the closing coil.

③ Electric trip

Remote trip can be operated by the trip coil or UVT coil.

Note) UVT is not equipped as standard and requires additional option selection.

Main contacts are operated by the energy of the spring mechanism and closing spring is charged by the motor in the mechanism.

Breaker is closed by closing coil and tripped by trip coil.

These operations are repeated in VCB as shown in the below sequence chart.

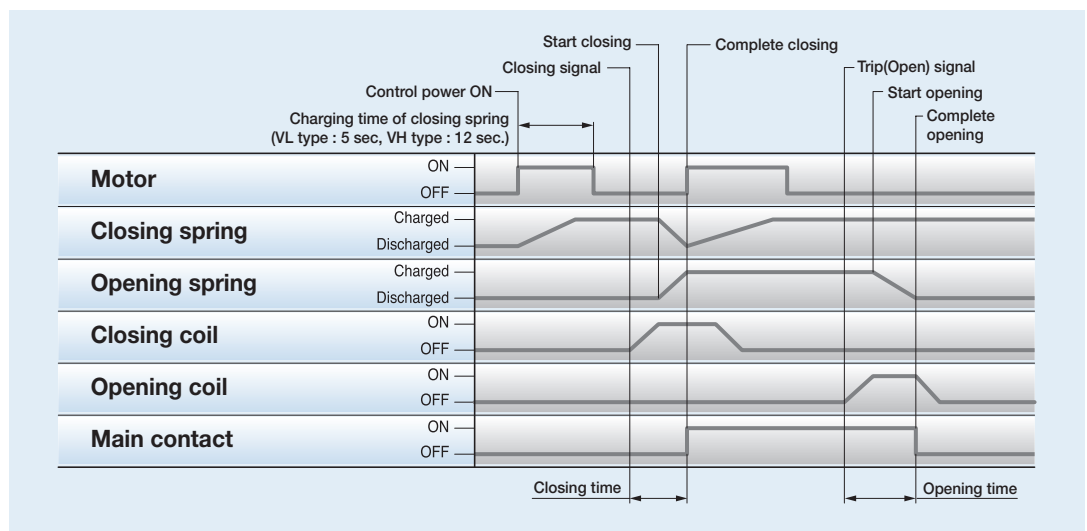

Sequence of the switching mechanism

The interruption of vacuum interrupters

The interruption of VCB is carried out by the vacuum interrupters.

Interrupter contacts as a key part made of copper - chromium (CuCr) material with spiral shape have low contact wear characteristics and withstand voltage is excellent.

Spiral contacts make the arc generated between the surfaces of contacts rotated around the surface of contact by the induced magnetic field generated due to the spiral contact structure, which results in preventing local heating, thereby corruption and interrupting instantaneously.

The vacuum rate within the VI is very high (approximately 5×10^{-5} Torr) and the spacing between fixed contact and movable contact is about 6~20mm, depending on the voltage. The contacts are in a structure that arc can easily be extinguished and the surfaces of the contacts are made of special alloy (copper-chromium) and the interior is completely sealed to prevent loss of vacuum. Therefore the wearing of the contacts can be minimized in the event of short-circuit and the arc energy by overvoltage or switching can be reduced effectively.

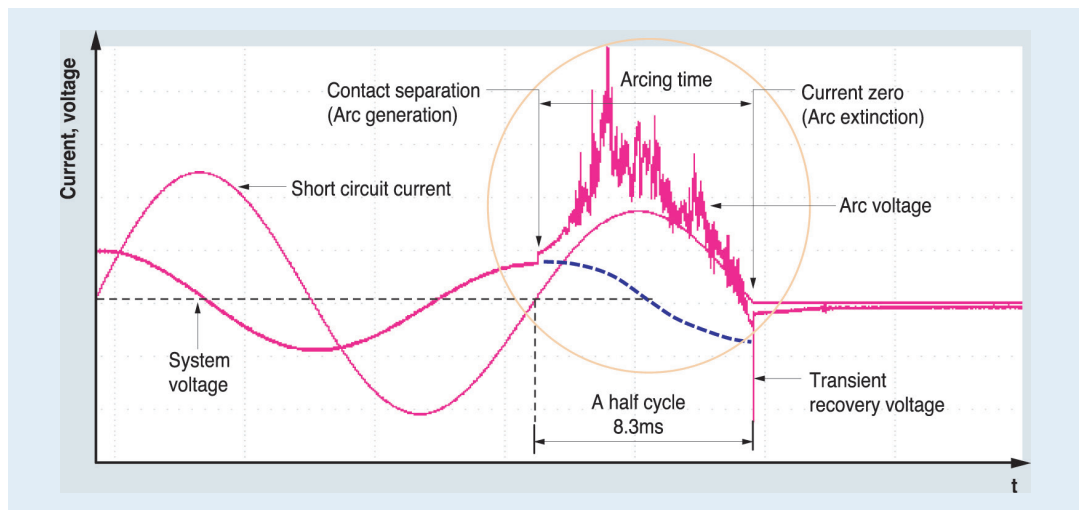
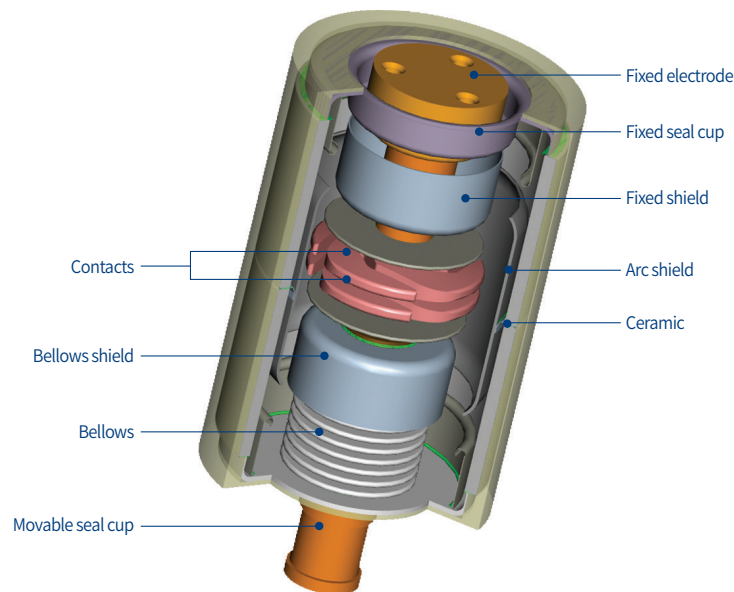

An example of oscillogram obtained through the interrupting test using LC resonant circuit

Basic functions and interrupting operation

The interruption of vacuum interrupters

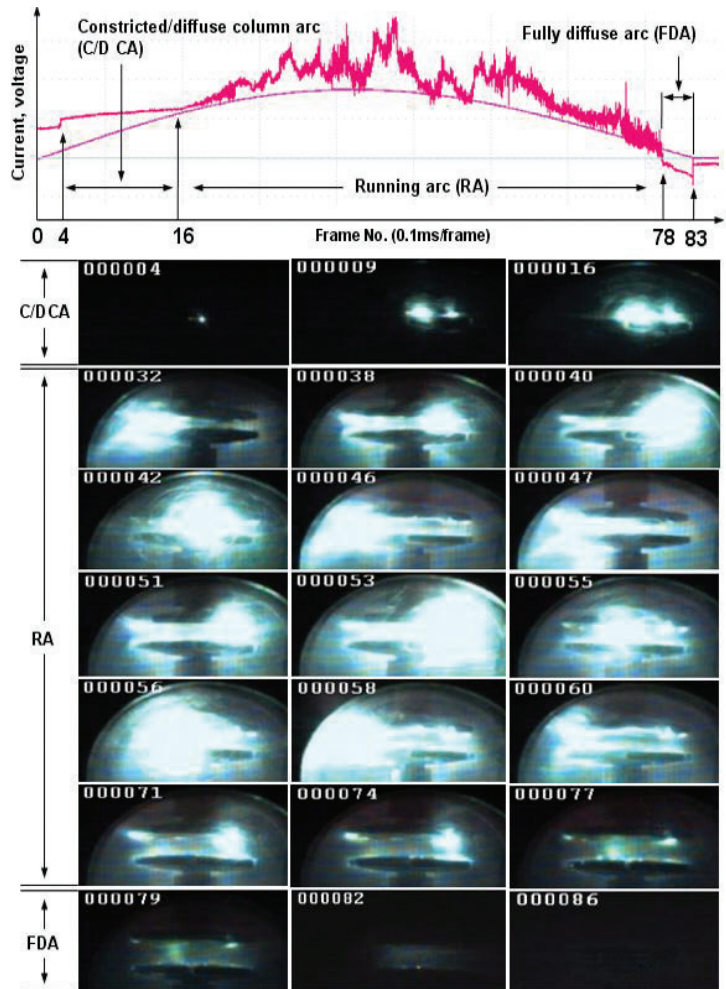

Arc voltage waveforms and arc image captured during arcing time

In case of using the flat contact any of the designs do not reflect on when contacts are opening the arc with high temperature is contracted and fixed in the center of the contacts, Which is called pinch effect. To prevent the effect two kinds of contact shapes are designed. One is Axial magnetic field which spreads the arc before its contraction, and the other is Radial magnetic field which permits the contraction of the arc but makes it rotated to disperse the energy. Because contracted arc is shaped like a cylinder it is called Contracted arc or columnar arc.

Spiral contact structure (Radial magnetic field), using the force ($F = j \times B$) generated by the interaction of the radial magnetic field caused by the current flowing through the arc between two contacts, disperse the arc energy evenly on the surface of contact by rotating the arc that is contracted by the pinch effect so as to minimize contact damage. The images show arc behavior during the arcing time of about 8ms by shooting with high-speed camera capable of shooting 10,000 frames per sec. (0.1ms/frame) by focusing on parts of the arcing time on the above graph and simultaneously measured arc voltage also represented to show arc state by section.

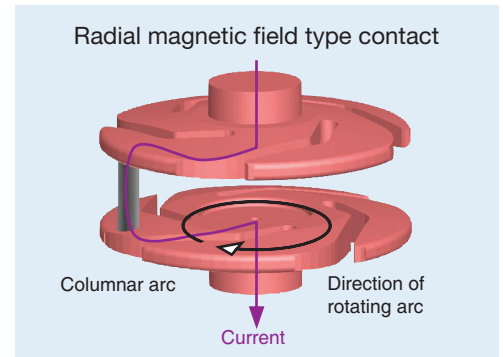

Arc driving principle in the contacts of Radial magnetic field

Standards and certification

Susol VCB has been type tested and obtained certifications according to the latest IEEE/ANSI standard at international testing laboratory and can be installed and applied at the environment and conditions in accordance with the standard.

■ Standard

- IEEE Std C37.09, ANSI C37.54, UL Listed & CSA

■ Test and certification

• Test report (KERI)



Standard Use Environment for Susol VCB

The operation characteristic of Vacuum Circuit Breaker such as insulation and endurance is often influenced largely by external environment and thus should be applied appropriately with conditions of the place where it is used taken into consideration.

The following values are the limits have been set in accordance with IEEE C37.04

Ambient Temperature

- maximum temperature: +40°C
- 24-hour average maximum temperature: +35°C
- minimum temperature: -5°C

Altitude

- 1000m or less above sea level

Relative Humidity

- 24 hours average value: 95% or less
- One month average: 90% or less

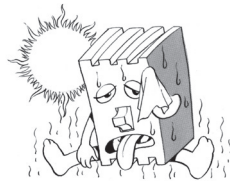

- If a standard circuit breaker is used in high temperature exceeding 40°C, you are advised to use it according to the current corrected for each level of ambient temperature in catalog.
- If used in conditions of high humidity, the dielectric strength or electric performance may be degraded.

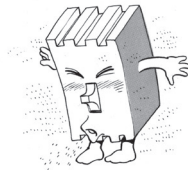

- It is highly recommended to use a dust cover or anti-humid agent if it is used in dusty and humid conditions.
- Excessive vibration may cause a trip breaker such as connection fault or flaw on mechanical parts.

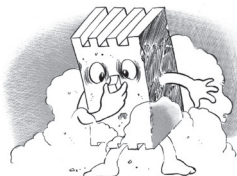

- If it is left CLOSE or OPEN for a long time, it is recommended to switch load current on a regular basis.
- It is recommend to put it in the sealed protection if corrosive gas is prevalent.

Technical data

Special Use Environment

The circuit breaker is designed for use in standard use environment specified in Section 4. 1 of IEEE C37.04. Concerning the special use environments as below the special use conditions are required to be considered, thus please contact us in advance.

- where altitude and ambient temperature are out of standard use environment. (-40°C)
- where a strong sea breeze blows
- when usually used in a humid place
- where a lot of steam or oil steam exists
- where explosive, flammable and other harmful gases might permeate the breaker
- In a dusty place
- where abnormal vibration or shock exists
- where a lot of ice and snow exist
- other special conditions

Withstand voltage compensation according to altitude

If the breaker is used in areas of sea level higher than 1000m the degradation of insulation performance should be taken into consideration.

80	38	150
60	27	125
36	15	95
19	4.76	60
Ud [kV/1min]	Ur[kV]	Up [kV/1.2 × 50μs]
Power Frequency Withstand Voltage		Impulse Withstand Voltage

<Table 1> Criteria of withstand voltages by rated voltages specified in IEEE C37.04

Special Use Environment

Withstand voltage compensation according to altitude

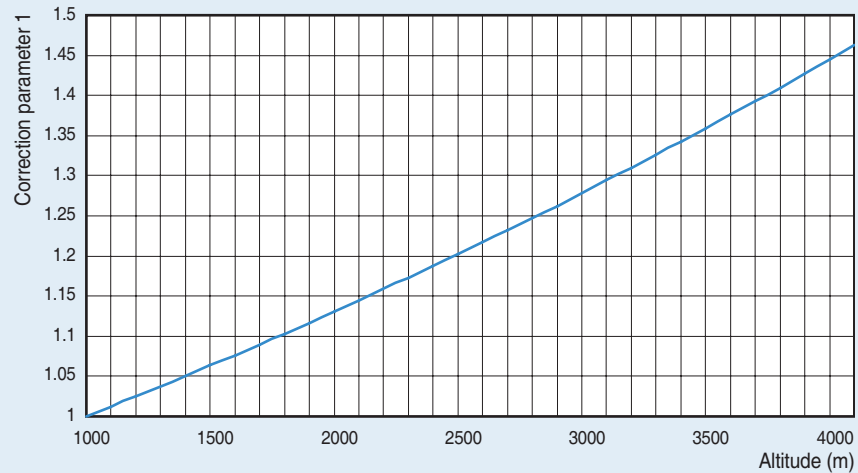

<Fig.1 > withstand voltage correction parameter 1 by altitude (based on a required withstand voltage)

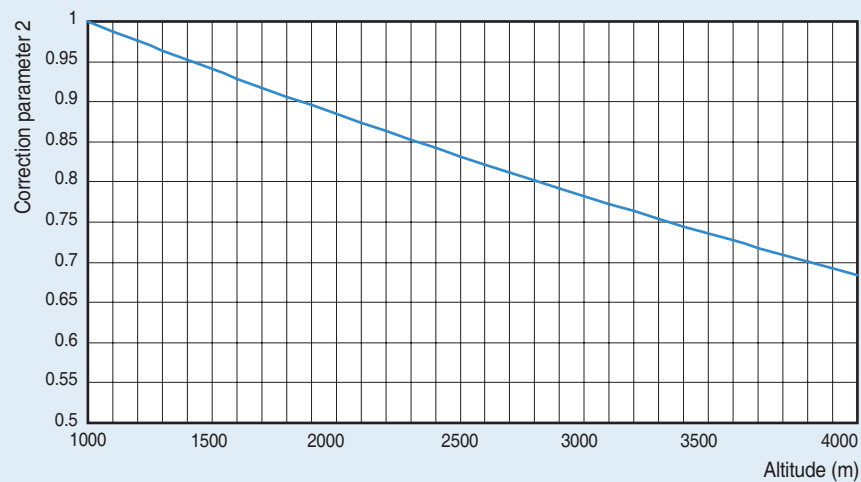

<Fig.2 > withstand voltage correction parameter 2 by altitude (based on a applicable withstand voltage)

Ex) Selecting a breaker to be used in a place of 2500m above sea level with a rated voltage 4.76kV (correction parameter 1 applied)

- correction parameter at 2500m is 1.2
- criteria of withstand voltage by rated voltage:
Power Frequency Withstand Voltage (U_d) = 19kV, Impulse Withstand Voltage (U_p) = 60kV
- requirements withstand voltage criteria:
Power Frequency Withstand Voltage (U_d) = $19 \times 1.2 = 22.8$ kV, Impulse Withstand Voltage (U_p) = 72kV
Therefore rated voltage 15kV breaker shall apply to satisfy the required withstand voltage.

Ex) To apply a breaker with a rated voltage 15kV to the place of 2,500m above sea level (correction parameter 2 applied)

- correction parameter at 2500m is 0.825
- dielectric strength of VCB : Power Frequency Withstand Voltage (U_d) = $36 \times 0.825 = 29.7$ kV,
Impulse Withstand Voltage (U_p) = $95 \times 0.825 = 78.4$ kV/ $1.2 \times 50\mu$ s
Therefore above breaker with rated voltage 15kV shall apply to rated voltage system 4.76kV at the altitude.

Technical data

Rated current compensation in accordance with ambient temperature

When normal ambient temperature exceeds the temperature specified in the environment the following formula help to select the applicable current.

$$I_a = I_r \left(\frac{\Theta_{\max} - \Theta_a}{\Theta_r} \right)^{1/2}$$

I_a : allowable continuous current in the actual ambient temperature Θ_a
 I_r : rated current at 40°C ambient temperature
 Θ_{\max} : acceptable overall temperature of the hottest spot
 Θ_a : the actual ambient temperature expected at -30°C and 60°C
 Θ_r : allowable temperature in the hottest place at rated current

Ex) The calculation of the applicable load current value when a breaker with rated current 2000A is used at 55 °C ambient temperature
 $I_a = 2000 \times ((105-55)/65)^{1/2} = 2000 \times 0.87 = 1754A$

Rated current (A)	Ambient temperature (°C)									
	20	25	30	35	40	45	50	55	60	
4000	4000	4000	4000	4000	4000	3843	3679	3508	3328	
3000	3000	3000	3000	3000	3000	2882	2760	2631	2496	
2750	2750	2750	2750	2750	2750	2642	2530	2412	2288	
2500	2500	2500	2500	2500	2500	2420	2300	2193	2080	
2000	2000	2000	2000	2000	2000	1922	1840	1754	1664	
1200	1200	1200	1200	1200	1200	1153	1104	1052	998	

<Table 2> Allowable load current by ambient temperature

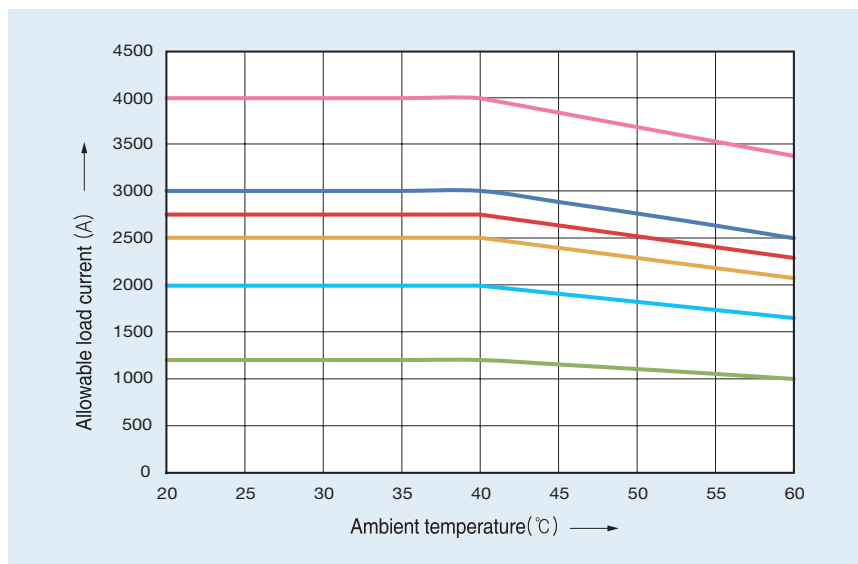

<Figure 3> Allowable load current by ambient temperature

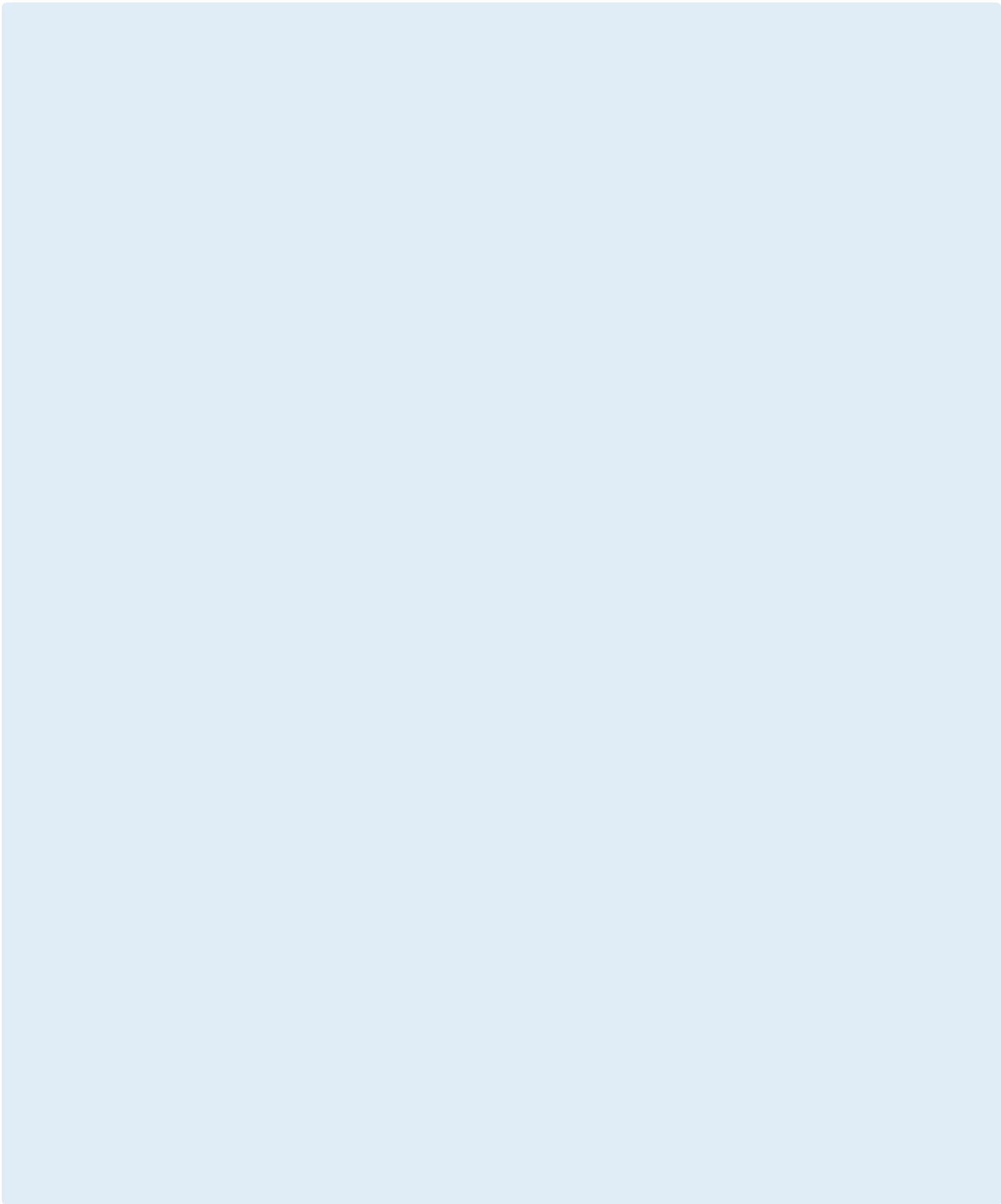



Safety Instructions

- For your safety, please read user's manual thoroughly before operating.
- Contact the nearest authorized service facility for examination, repair, or adjustment.
- Please contact qualified service technician when you need maintenance.
Do not disassemble or repair by yourself!
- Any maintenance and inspection shall be performed by the personnel having expertise concerned.



www.LSElectricAmerica.com

■ LS ELECTRIC America Inc. Chicago Head Office

980 Woodlands Parkway, Vernon Hills, IL 60061 USA
Tel: 1-800-891-2941 E-Mail: sales.us@lselectricamerica.com

■ Headquarter

127 LS-ro (Hogye-dong) Dongan-gu, Anyang-si, Gyeonggi-Do, 14119, Korea

■ Seoul Office

LS Yongsan Tower, 92, Hangang-daero, Yongsan-gu, Seoul, 04386, Korea
Tel: 82-2-2034-4916, 4684, 4429

■ Overseas Subsidiaries

• LS ELECTRIC Japan Co., Ltd. (Tokyo, Japan)

Tel: 81-3-6268-8241 E-Mail: japan@lselectric.com

• LS ELECTRIC (Dalian) Co., Ltd. (Dalian, China)

Tel: 86-411-8730-5872 E-Mail: china.dalian@lselectric.com.cn

• LS ELECTRIC (Wuxi) Co., Ltd. (Wuxi, China)

Tel: 86-510-6851-6666 E-Mail: china.wuxi@lselectric.com.cn

• LS ELECTRIC Vietnam Co., Ltd. (Hanoi, Vietnam)

Tel: 84-222-2221-110 E-Mail: vietnam@lselectric.com

• LS ELECTRIC Middle East FZE (Dubai, U.A.E.)

Tel: 971-4-886-5360 E-Mail: middleeast@lselectric.com

• LS ELECTRIC Europe B.V. (Hoofddorp, Netherlands)

Tel: 31-20-654-1424 E-Mail: europartner@lselectric.com

• LS ENERGY SOLUTIONS LLC (Charlotte, USA)

Tel: 1-704-587-4051 E-Mail: cmfeldman@ls-es.com

• LS ELECTRIC Türkiye Co., Ltd. (Istanbul, Türkiye)

Tel: 90-212-806-1252 E-Mail: turkiye@lselectric.com

• LS ELECTRIC IBERIA S.L.U. (Madrid, Spain)

Tel: 34-910-28-02-74 E-Mail: iberia@lselectric.com

■ Overseas Branches

• LS ELECTRIC Tokyo Office (Japan)

Tel: 81-3-6268-8241 E-Mail: tokyo@lselectric.com

• LS ELECTRIC Beijing Office (China)

Tel: 86-10-5095-1631 E-Mail: china@lselectric.com.cn

• LS ELECTRIC Shanghai Office (China)

Tel: 86-21-5237-9977 E-Mail: china@lselectric.com.cn

• LS ELECTRIC Guangzhou Office (China)

Tel: 86-20-3818-2883 E-Mail: china@lselectric.com.cn

• LS ELECTRIC Chengdu Office (China)

Tel: 86-28-8670-3201 E-Mail: china@lselectric.com.cn

• LS ELECTRIC Qingdao Office (China)

Tel: 86-532-8501-2065 E-Mail: china@lselectric.com.cn

• LS ELECTRIC Nanjing Office (China)

Tel: 86-25-8467-0005 E-Mail: china@lselectric.com.cn

• LS ELECTRIC Bangkok Office (Thailand)

Tel: 66-90-950-9683 E-Mail: thailand@lselectric.com

• LS ELECTRIC Jakarta Office (Indonesia)

Tel: 62-21-2933-7614 E-Mail: indonesia@lselectric.com

• LS ELECTRIC Moscow Office (Russia)

Tel: 7-499-682-6130 E-Mail: info@lselectric-ru.com

• LS ELECTRIC America Western Office (Irvine, USA)

Tel: 1-949-333-3140 E-Mail: america@lselectric.com

• LS ELECTRIC India Office (India)

Tel: 91-80-6142-9108 E-Mail: info_india@lselectric.com

• LS ELECTRIC Singapore Office (Singapore)

Tel: 65-6958-8162 E-Mail: singapore@lselectric.com

• LS ELECTRIC Italy Office (Italy)

Tel: 39-030-8081-833 E-Mail: italia@lselectric.com