

Top 100
Global
Innovator
for 10 years

Renewable energy solution



LS[▶]**ELECTRIC**

FUTURING SMART ENERGY

We open up a brighter future through efficient and convenient energy solutions.



LS a leader of the electric power and automation industry, offers smart convergence solutions by combining ICT and DC technology.
Smart Power Transmission Solutions / Smart Power Distribution Solutions Smart Automation Solutions

Renewable Energy is key factor to reduce green home gas emissions for the next generation



CONTENTS

Summary 04

DC Components

DC MCCB	12
DC MCB	28
DC Contactor	30
SPD	32
DC Air Circuit Breakers	34
DC Switch-Disconnecter	36
DC Compact Switch-Disconnecter	54
High Voltage DC Relay	68

AC Components

Susol MCCB	76
Susol ACB	89
Compact ACB	104
Susol VCB	113
Metasol MS	131
Susol Busways	149
XGIPAM	153
Susol RMU	157
Transformer	167

Products for Photovoltaic Power Generation

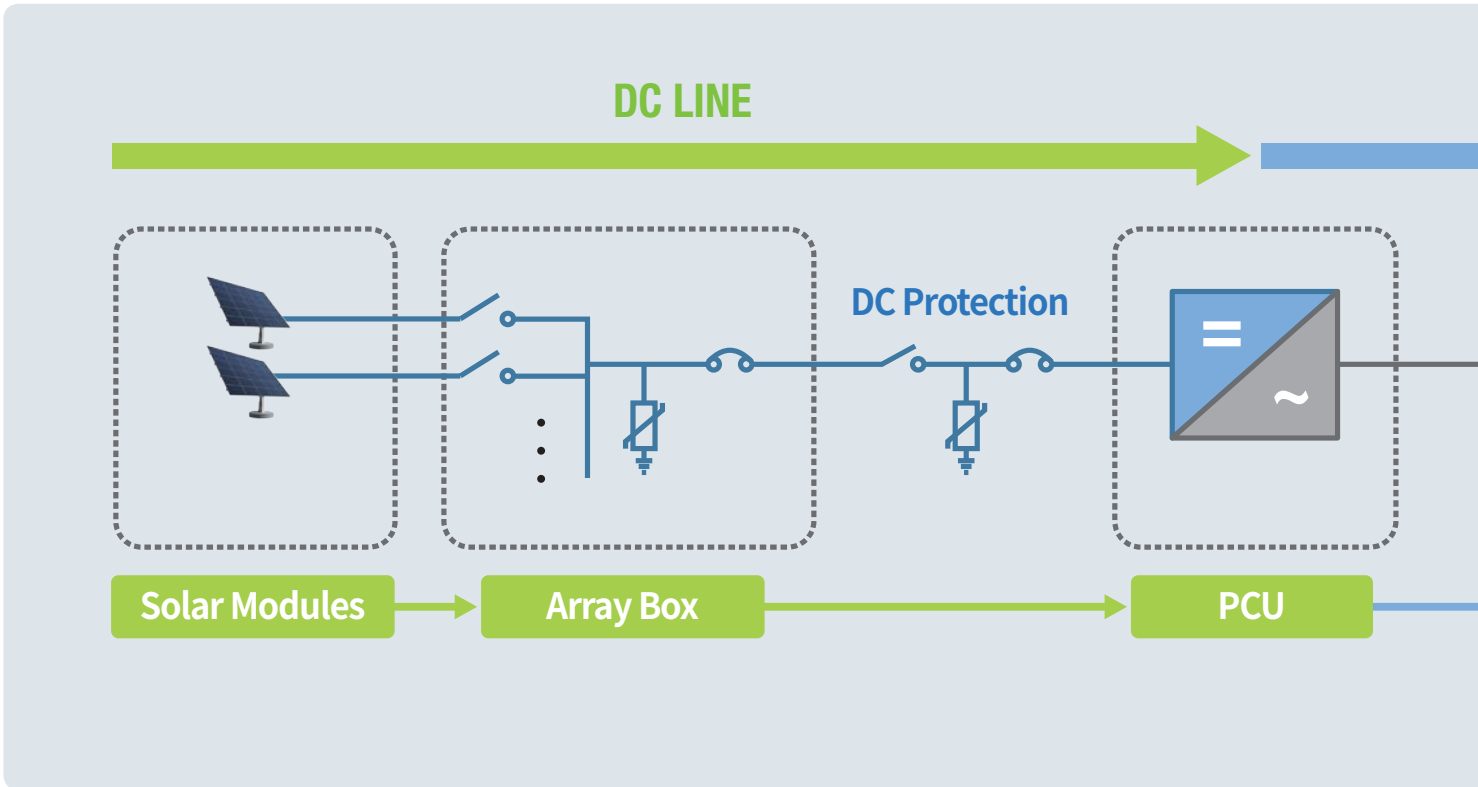

P.12 DC MCCB



- TD100~TS800**
- In 16~800A
 - Ue DC 500~1500V
 - Icu 40kA

P.24 Switch Disconnecter



- TS1600NA**
- In 1000~1600A
 - Ue DC 1150V
 - Icw 25kA 1s

P.36 Switch Disconnecter



- DDH / DDV**
- In 800~4000AF
 - Ue DC 750~1500V
 - Icw 100kA 1s

P.28 DC MCB



- BK63H**
- In 1~63A
 - Ue DC 250~1000V
 - Icu 10kA

P.30 DC Contactor



- MD-30a, 60a, 100a**
- Ie 120, 100, 60, 35A
 - Ue DC 125,250,500V,1000V
 - DC-2~5, DC-1 ratings
 - 3.7kW~22kW

P.68 High Voltage DC Relay



- GPR010~GPR-H500-A**
- Ie 10~500A
 - Ue 450~1500V

P.32 DC SPD



- BK20S-DC1500**
- Un DC 110~1500V
 - Up ≤1.0~4.5kV
 - I_{max} 40kA
 - t_a <25ns

AC LINE

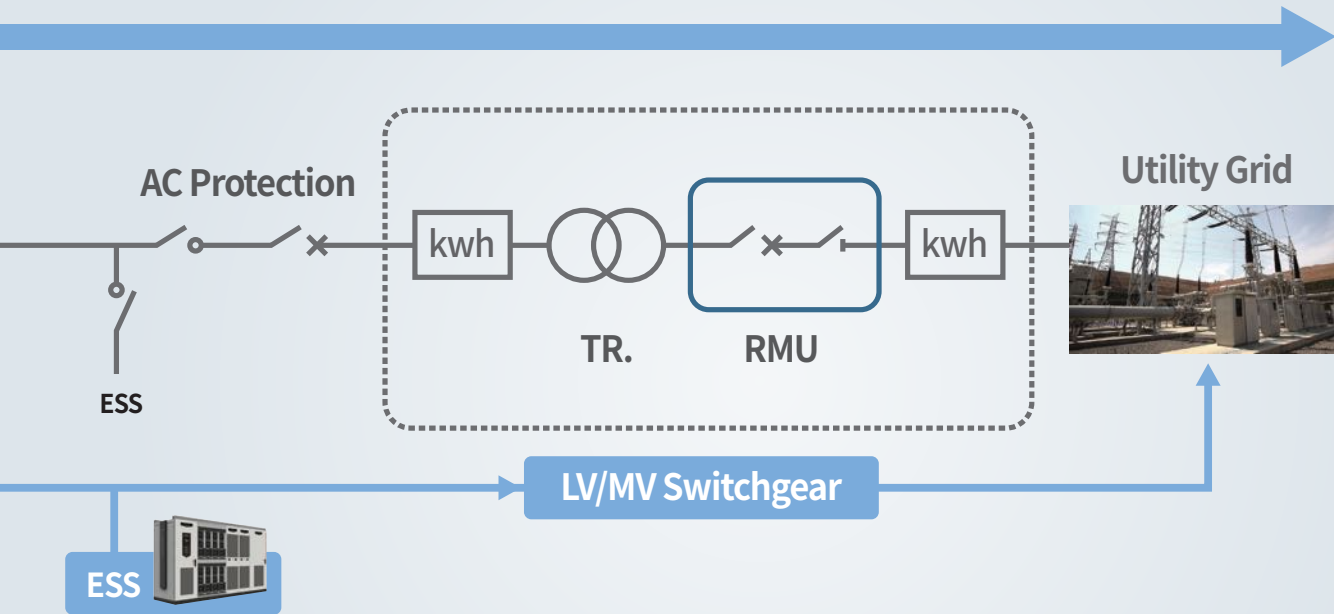

P.80 MCCB



TS1000~1600

- In 1000~1600A
- Icu 50~150kA
- AC 380/415V

P.135 Contactors



MC-1260a, 2650a

- Ie 1260~2650A
- Ue AC 1000V
- Coil: AC 100~240V
DC 100~220V

P.167 Cast Resin TR



- Rated Power
 - Up to 25MVA
- Rated Voltage
 - Primary: Up to 36kV
 - Secondary: Up to 1200V

P.157 RMU



- Rated Voltage: Up to 36kV
- Ir: 630A
- Isc 21kA/3s
- M1/E3
- IAC AFAL 21kA/0.5s

P.89 ACB



AH

- In 630~6300A
- Icu 65~150kA
- Ue 690V

P.153 XGIPAM



- XGIPAM Bay, F, M, T, DG
- PT : 110V, CT : 5A,
ZCT : 1.5mA
- AC110V, DC110~125V

P.171 Oil Immersed TR.



- Rated Power
 - Up to 80MVA
- Rated Voltage
 - Up to 72kV

P.157 Packaged Solution



RMU+TR+LV



RMU+TR+PCU

Products for Grid Protection of Wind Power

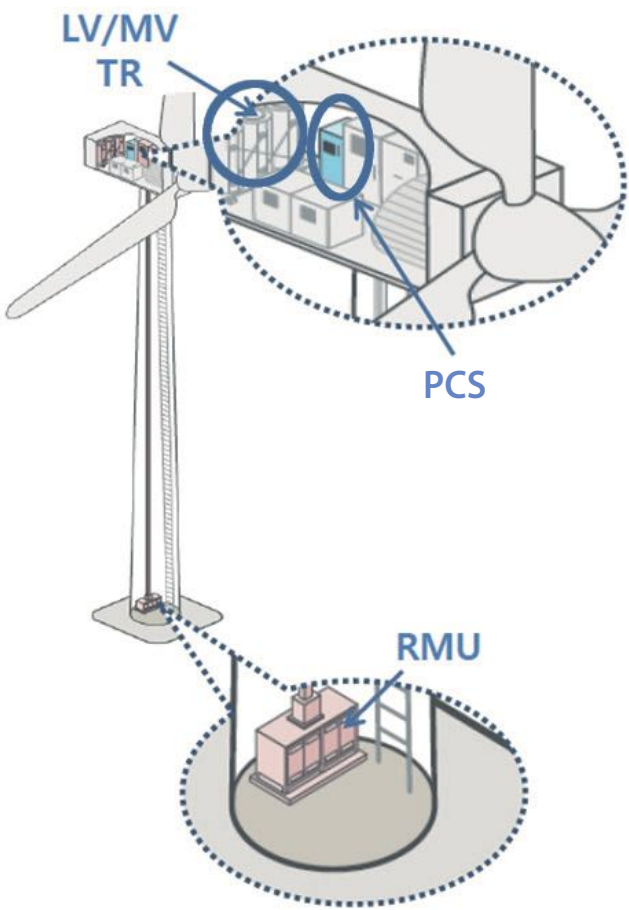
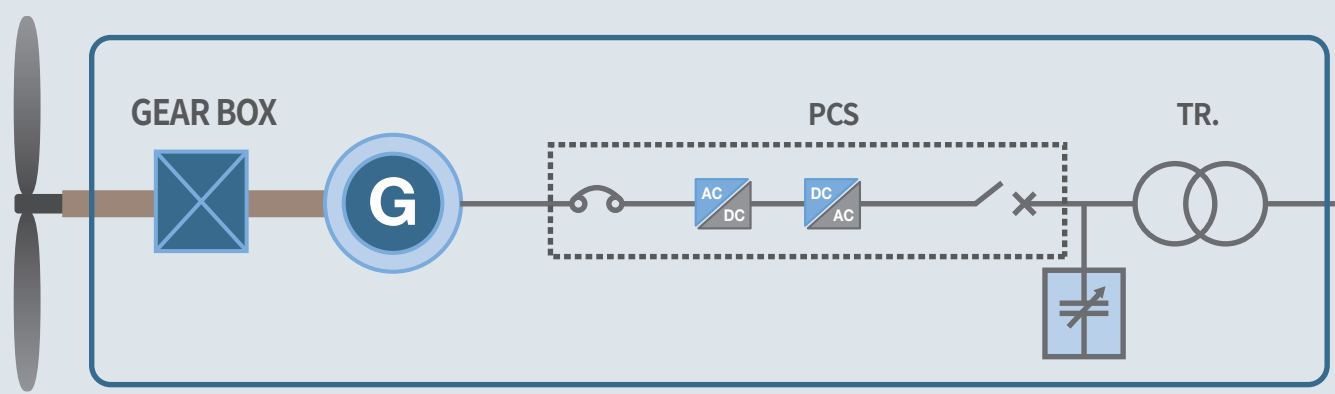

P.80 MCCB



- TS1000~1600**
- In 1000~1600A
 - Icu 50~150kA
 - AC 380/415V

P.89 ACB



- AH**
- In 630~6300A
 - Icu 65~150kA
 - Ue 690V

P.30 DC Contactor



- MD-30a, 60a, 100a**
- Ie 120, 100, 60, 35A
 - Ue DC 125, 250, 500V, 1000V
 - DC-2~5, DC-1 ratings
 - 3.7kW~22kW

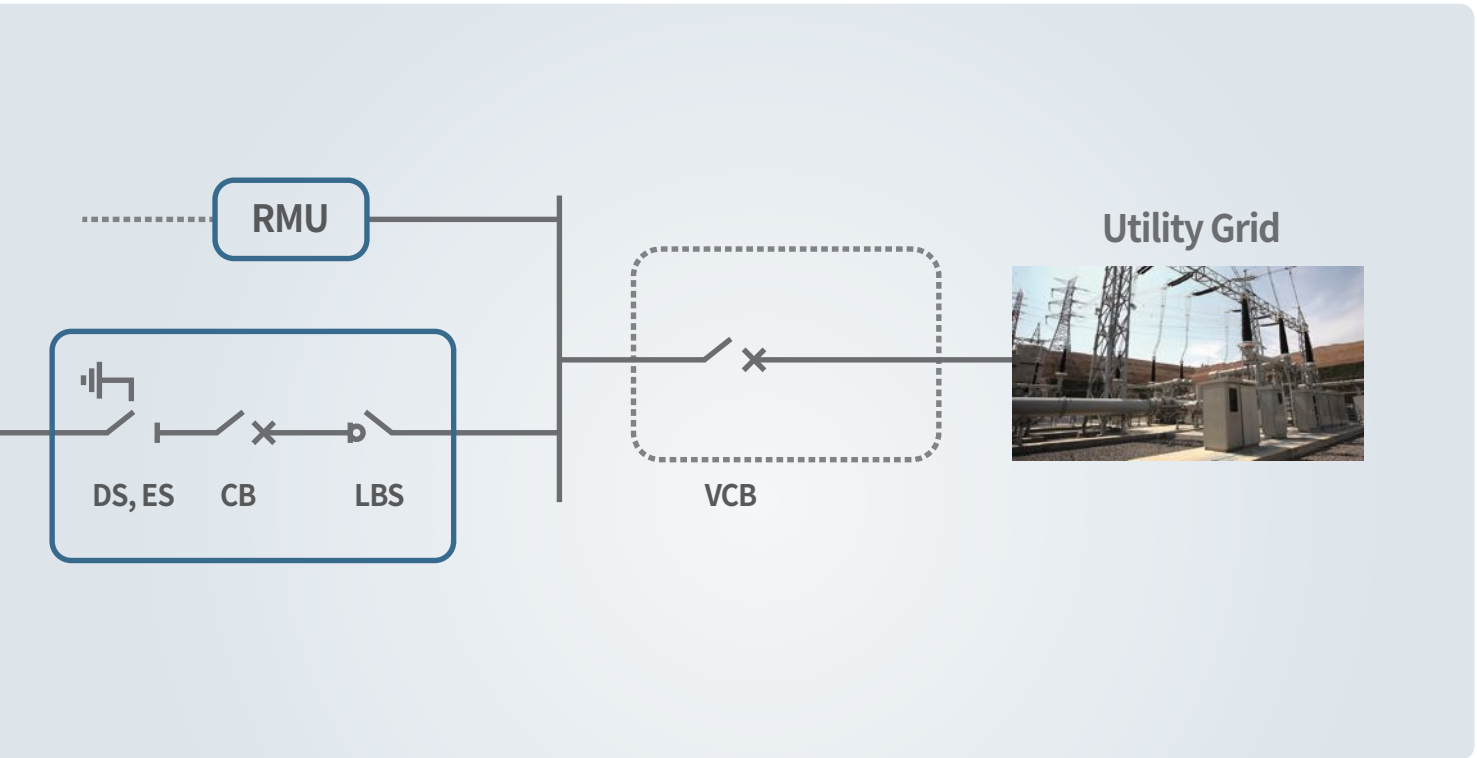

P.167 Cast Resin TR.



- Rated Power
 - Up to 25MVA
- Rated Voltage
 - Primary: Up to 36kV
 - Secondary: Up to 1200V

P.157 RMU



- Rated Voltage: Up to 36kV
- Ir: 630A
- Isc 21kA/3s
- M1/E3
- IAC AFAL 21kA/0.5s

P.113 VCB



- VL~25**
- Ir: 630A/24kV
 - Breaking current: 25kA
 - M2/E2/C2

P.171 Oil Immersed TR.



- Rated Power
 - Up to 80MVA
- Rated Voltage
 - Up to 72kV

- CSS (RMU+TR+LV)



P.115 CB Compartment



- Ir: 630A/24kV
- Breaking current: 25kA
- M2/E2/C2

Products for Energy Storage System

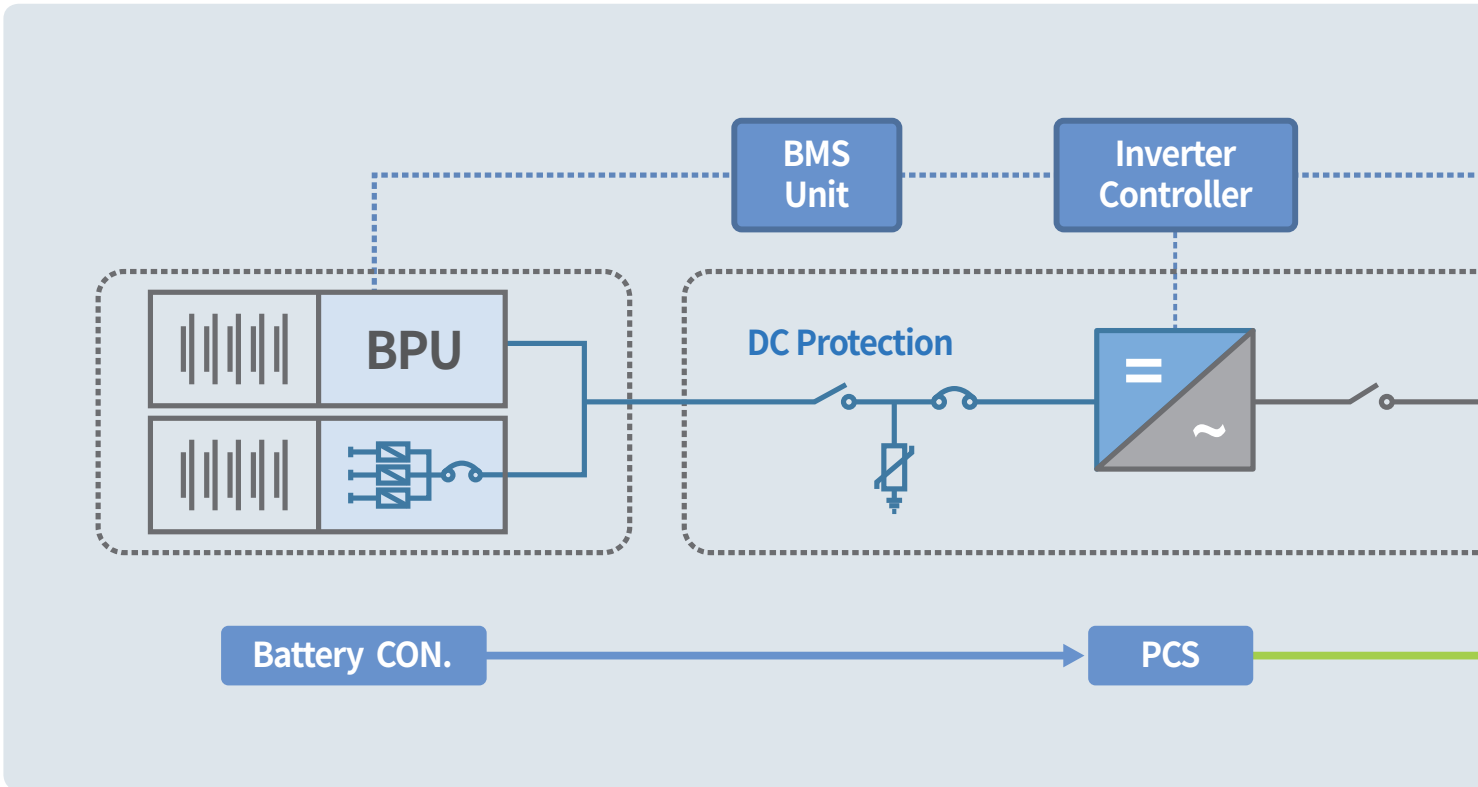

P.12 DC MCCB



- TD100~TS800**
- In 16~800A
 - Ue DC 500~1500V
 - Icu 40kA

P.30 DC Contactor



- MD-30a,60a,100a**
- Ie 120, 100, 60, 35A
 - Ue DC 125, 250, 500V, 1000V
 - DC-2~5, DC-1 ratings
 - 3.7kW~22kW

P.36 Switch Disconnecter



- DDH / DDV**
- In 800~4000AF
 - Ue DC 750~1500V
 - Icw 100kA 1s

P.135 Contactor



- MC-1260a, 2650a**
- Ie 1260~2650A
 - Ue AC 1000V
 - Coil: AC 100~240V
 - DC 100~220V

P.68 High Voltage DC Relay



- GPR010~GPR-H500-A**
- Ie 10~500A
 - Ue 450~1500V

P.32 DC SPD



- BK20S-DC1500**
- Un DC 110~1500V
 - Up ≤1.0~4.5kV
 - I_{max} 40kA
 - t_a <25ns

P.149 Busways



- SS type**
- In AL 630~6000A
 - Cu 630~7500A
 - I_{sc} Al 4000A/200kA
 - Cu 4000A/220kA for 1s

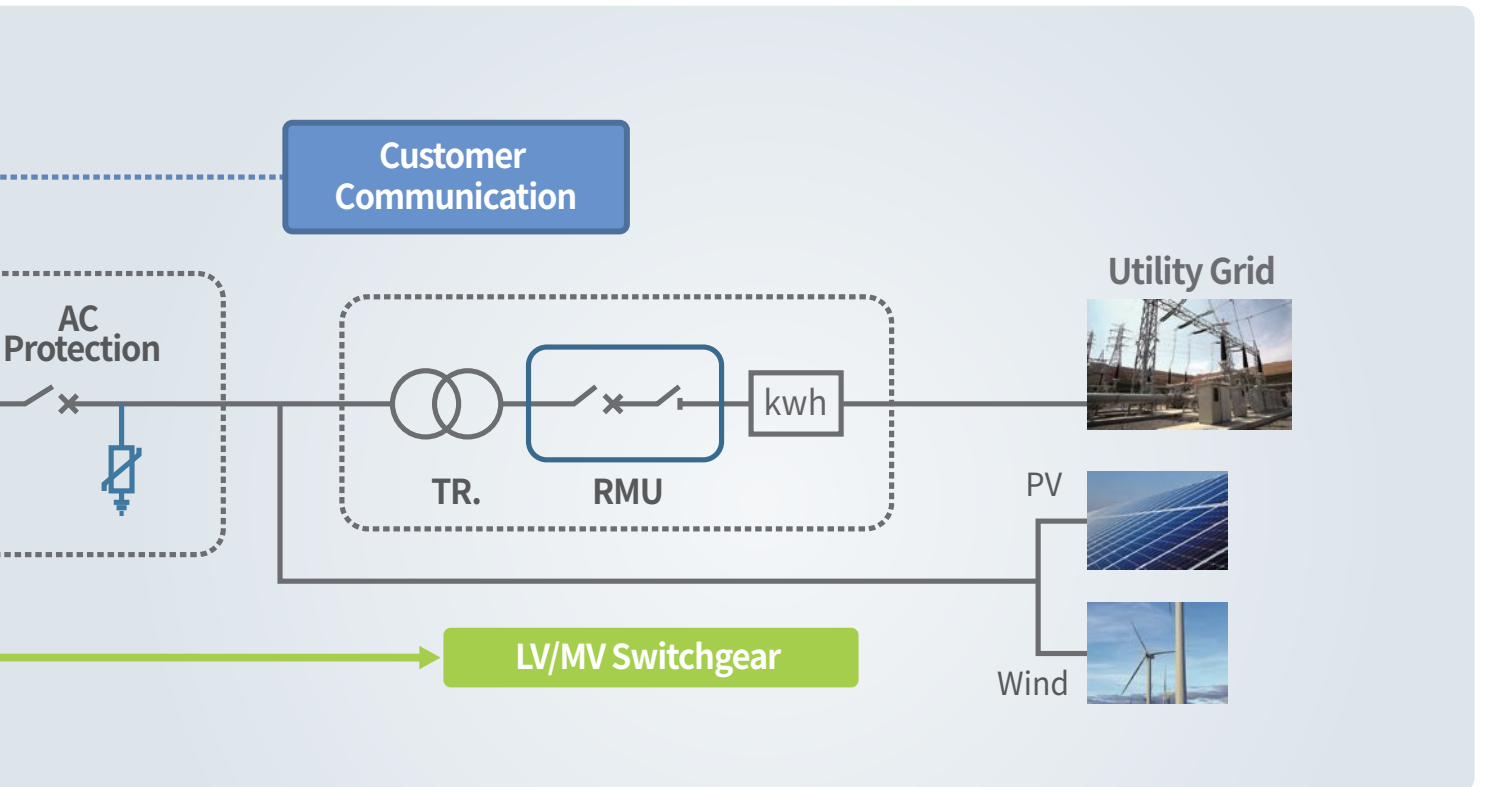

P.80 MCCB



TS1000~1600

- In 1000~1600A
- Icu 50~150kA
- AC 380/415V

P.167 Cast Resin TR.



- Rated Power
 - Up to 25MVA
- Rated Voltage
 - Primary: Up to 36kV
 - Secondary: Up to 1200V

P.157 RMU



- Rated Voltage: Up to 36kV
- Ir: 630A
- Isc 21kA/3s
- M1/E3
- IAC AFAL 21kA/0.5s

P.113 VCB



VL~25

- Ir: 630A/24kV
- Breaking current: 25kA
- M2/E2/C2

P.89 ACB



AH

- In 630~6300A
- Icu 65~150kA
- Ue 690V

P.171 Oil Immersed TR.



- Rated Power
 - Up to 80MVA
- Rated Voltage
 - Up to 72kV

P.153 XGIPAM



- XGIPAM Bay, F, M, T, DG
- PT : 110V, CT : 5A, ZCT : 1.5mA
- AC110V, DC110~125V

Susol

Super Solution

Metasol

Meta Solution



DC Components

You can count on us.

Global leader that puts customer values as the highest priority

We promise to return the best value for our customers. Committed to develop global leading products, we endeavor to expand overseas market as well as domestic market. Join us where you can share bright future.

DC MCCB	12
DC MCB	28
DC Contactors	30
SPD	32
DC ACB	34
DC Switch Disconnecter	36
DC Compact Switch-Disconnecter	54
High Voltage DC Relay	68

DC MCCB (100~800AF)

- Susol MCCB is suitable for DC application such as Photovoltaic Circuit Breaker, UPS and datacenter
- DC short circuit test tested by VDE
- Higher nominal voltage range up to 1000 VDC
- Rated Current : 16A~800A
- No of Pole: 2/3/4Pole



Rating

Model		TD100	TD160	TS100	TS160	TS250	TS400	TS630	TS800
Frame size	(AF)	100	160	100	160	250	400	630	800
Rated current, I _n	(A)	16, 20, 25, 32, 40, 50, 63, 80, 100	100, 125, 160	40, 50, 63, 80, 100	100, 125, 160	125, 160, 200, 250	300, 400	500, 550	700 ^{Note 5)} , 800
No. of poles	(Pole)	2, 3, 4	2, 3, 4	2, 3, 4	2, 3, 4	2, 3, 4	2, 3, 4	2, 3, 4	2, 3, 4
Rated operational voltage, U _e (Vdc)	2Pole	500	500	500	500	500	500	500	500
	3Pole	750	750	750	750	750	750	750	750
	4Pole	1000	1000	1000	1000	1000	1000	1000	1000
Rated insulation voltage, U _i (V)	2Pole	800	800	800	800	800	800	800	800
	3Pole	800	800	800	800	800	800	800	800
	4Pole	1000	1000	1000	1000	1000	1000	1000	1000
Rated impulse withstand voltage U _{imp} (kV)		8	8	8	8	8	8	8	8
Rated ultimate short-circuit breaking capacity, I _{cu} (kA)	Type	H	H	H	H	H	H	H	H
Rated service breaking capacity, I _{cs} [%I _{cu}]	500VDC (2P)	40	40	40	40	40	40	40	40
	750VDC (3P)	40	40	40	40	40	40	40	40
Trip Unit ^{Note 4)} Function	1000VDC (4P)	40	40	40	40	40	40	40	40
	FTU	●	●	●	●	●	●	●	●
	FMU	●	●	●	●	●	●	●	●
	ATU	-	-	-	●	●	●	●	●

Note)

1. TD100/TD160 is the same Construction Frame.
2. TS100/TS160/TS250 is the same Construction Frame.
3. TS400/TS630 is the same Construction Frame.
4. Trip Unit Function have 3 Types (FTU/FMU/ATU)
 - FTU : Fixed thermal, fixed magnetic unit
 - FMU : Adjustable thermal, fixed magnetic unit
 - ATU : Adjustable thermal, adjustable magnetic unit
 (Not applicable to TS160 100A ATU)
5. 700A is only available for TS800FTU
6. 4Pole type MCCB is 4P4T.

DC Exemplary circuit diagrams

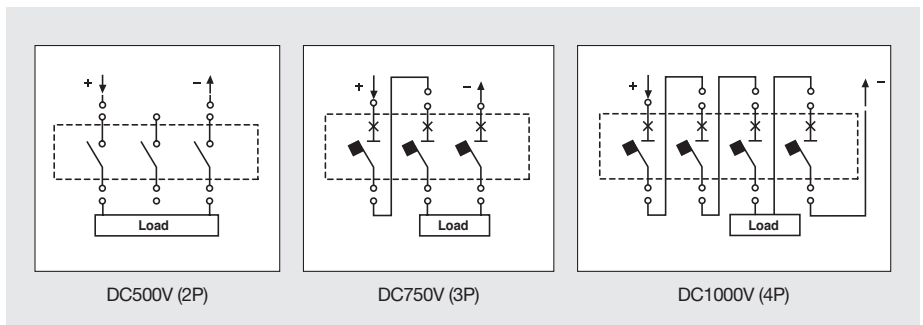

Connection method by DC voltage

Operating voltage (DC)	Center point Connected to earth (A)	One pole connected to earth (B)	Insulated from Earth (C)
~250V	A	A	A
~500V	A	B, C	A
~750V	F	C, E	B
~1000V	F	D	E, F

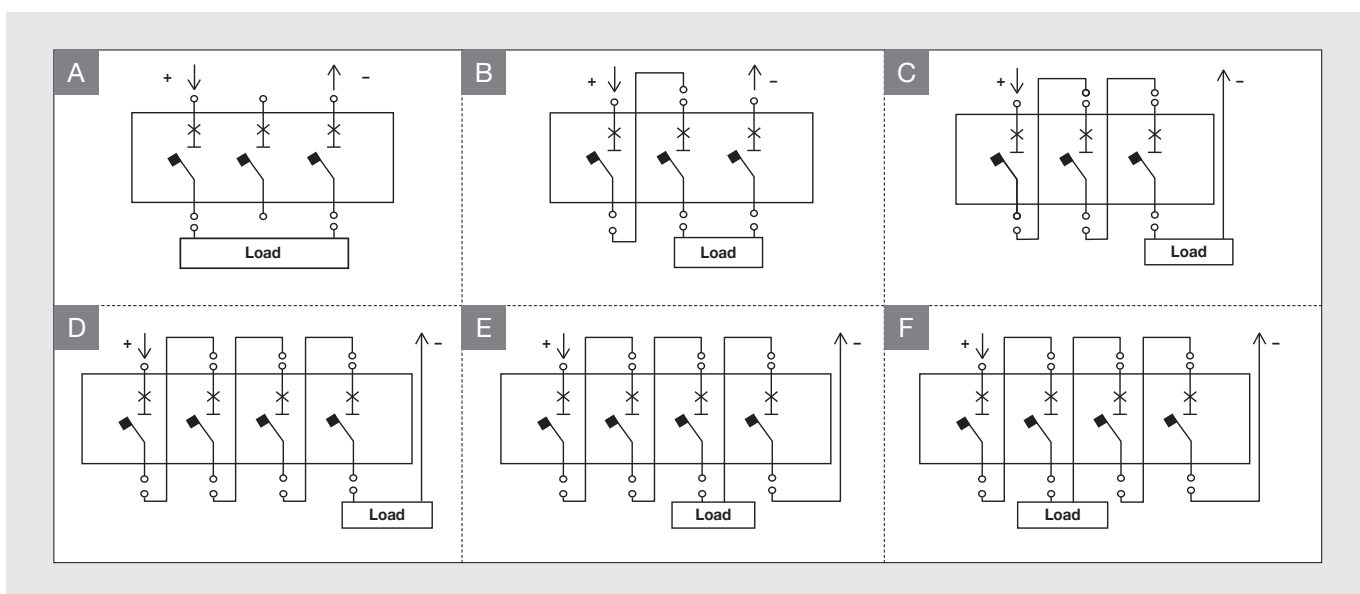

※ Application of 4P4D product when applying 4-pole product

Operating voltage (DC)	Center point Connected to earth (A)	One pole connected to earth (B)	Insulated from Earth (C)
~250V	A1	A1	A1
~500V	A1	B1, C1	A1
~750V	F1	C1, E1	B1
~1000V	F1	D1	E1, F1

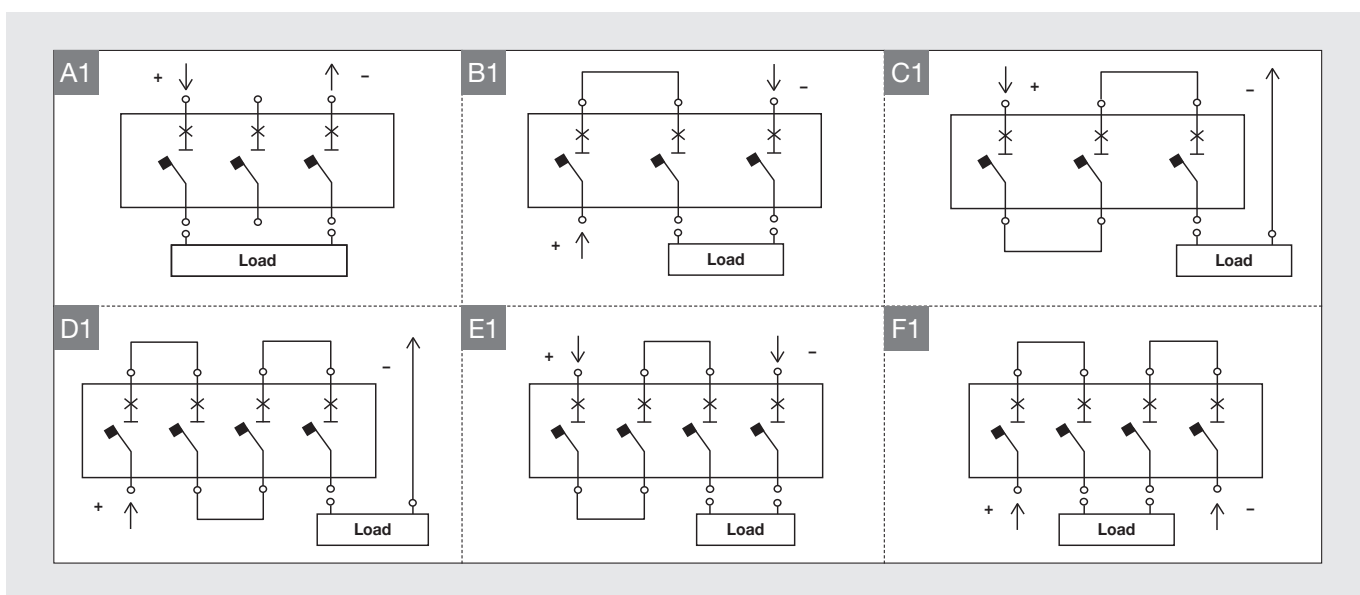

※ Application of 4P4D product when applying 4-pole product

DC MCCB (100~800AF)

Susol MCCB PV up to 800A

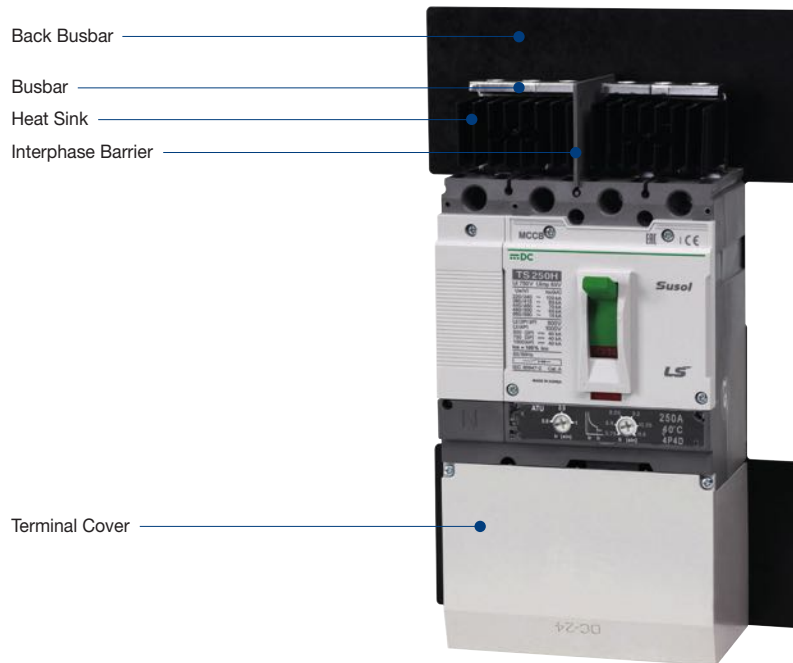

Accessories

Terminal cover



Busbar



Heatsink



Susol MCCB PV up to 800A

1. Basically, Heat sink and Busbar are optional accessories.
2. A set of Busbar parts is mounted on terminals of the chassis.
3. If Busbar parts are mounted only, it is available to refer to Derating table and if Heat sink parts are mounted additionally, please refer to Rated current table

Derating Table for AF

The following tables are based on the following assumptions;

- Maximum permissible temperature of busbars are 100°C
- T : Temperature around the circuit breaker and its connections

Note) 1. The values presented in the tables are the result of trials and theoretical calculations on the basis of the assumption mentioned above.

2. These tables are intended as an aid in designing connection, however, the actual values must be confirmed by tests on the installation.

Type	Rated Current (A)	Derating Current (A)	Terminal Connection Condition
TD100	16	16	TD160 Busbar 5t
	20	20	
	25	25	
	32	32	
	40	40	
	50	50	
	63	63	
	80	80	
TD160	100	100	TD160 Busbar 5t + Heat Sink
	125	113	
	160	144	
	125	125	
TS100	40	40	TS250 Busbar 5t
	50	50	
	63	63	
	80	80	
TS160	100	100	TS250 Busbar 5t
	125	125	
	160	160	
TS250	125	125	TS250 Busbar 5t + Heat Sink
	160	160	
	200	180	
	250	200	
	200	200	
TS400	250	250	TS630 Busbar Lower & Upper 6t
	300	300	
	400	360	
TS630	400	400	TS630 Busbar Lower & Upper 6t+Heat Sink
	500	400	TS630 Busbar Lower & Upper 6t
	550	440	TS630 Busbar Lower & Upper 6t
	500	500	TS630 Busbar Lower & Upper 6t+Heat Sink
TS800	550	550	TS800 Busbar Lower & Upper 6t
	700 *	630	
	800	640	
	700 *	700	
	800	800	TS800 Busbar Lower & Upper 6t+Heat Sink

Note) 1. * Only available for TS800 FTU

2. Dimension on the connection & busbar.

DC MCCB (100~800AF)

Susol MCCB PV up to 800A

Temperature Derating

Type	Rated Current (A)	Derating Current (A)	Compensated rated current in accordance with ambient temperature (A)																Terminal Connection Condition	
			10℃		20℃		30℃		40℃		45℃		50℃		60℃		70℃			
TD100	16	16	100%	16	100%	16	100%	16	100%	16	100%	16	100%	15	94%	14	88%	13	81%	TD160 Busbar 5t
	20	20	100%	20	100%	20	100%	20	100%	20	100%	19	95%	19	95%	18	90%	18	90%	
	25	25	100%	25	100%	25	100%	25	100%	25	100%	24	96%	23	92%	22	88%	21	84%	
	32	32	100%	32	100%	32	100%	32	100%	32	100%	31	97%	30	94%	29	91%	27	84%	
	40	40	100%	40	100%	40	100%	40	100%	40	100%	39	98%	38	95%	35	88%	33	83%	
	50	50	100%	50	100%	50	100%	50	100%	50	100%	49	98%	47	94%	44	88%	41	82%	
	63	63	100%	63	100%	63	100%	63	100%	63	100%	62	98%	60	95%	56	89%	52	83%	
	80	80	100%	80	100%	80	100%	80	100%	80	100%	78	98%	76	95%	71	89%	66	83%	
TD160	100	100	100%	100	100%	100	100%	100	100%	100	100%	98	98%	95	95%	89	89%	83	83%	TD160 Busbar 5t + Heat Sink
	100	100	100%	100	100%	100	100%	100	100%	100	100%	98	98%	95	95%	89	89%	83	83%	
	125	113	90%	113	90%	113	90%	113	90%	113	90%	109	87%	105	84%	99	79%	92	74%	
	160	144	90%	144	90%	144	90%	144	90%	144	90%	139	87%	135	84%	127	79%	119	74%	
TS100	125	125	100%	125	100%	125	100%	125	100%	125	100%	122	98%	119	95%	111	89%	104	83%	TS250 Busbar 5t
	160	160	100%	160	100%	160	100%	160	100%	160	100%	155	97%	150	94%	141	88%	131	82%	
	40	40	100%	40	100%	40	100%	40	100%	40	100%	39	98%	38	95%	35	88%	33	83%	
	50	50	100%	50	100%	50	100%	50	100%	50	100%	49	98%	47	94%	44	88%	41	82%	
TS160	63	63	100%	63	100%	63	100%	63	100%	63	100%	62	98%	60	95%	56	89%	52	83%	TS250 Busbar 5t + Heat Sink
	80	80	100%	80	100%	80	100%	80	100%	80	100%	78	98%	76	95%	71	89%	66	83%	
	100	100	100%	100	100%	100	100%	100	100%	100	100%	98	98%	95	95%	89	89%	83	83%	
TS250	100	100	100%	100	100%	100	100%	100	100%	100	100%	98	98%	95	95%	89	89%	83	83%	TS630 Busbar Lower & Upper 6t
	125	125	100%	125	100%	125	100%	125	100%	125	100%	122	98%	119	95%	111	89%	104	83%	
	160	160	100%	160	100%	160	100%	160	100%	160	100%	155	97%	150	94%	141	88%	131	82%	
TS400	125	125	100%	125	100%	125	100%	125	100%	125	100%	122	98%	119	95%	111	89%	104	83%	TS800 Busbar Lower & Upper 6t
	160	160	100%	160	100%	160	100%	160	100%	160	100%	155	97%	150	94%	141	88%	131	82%	
	200	180	90%	180	90%	180	90%	180	90%	180	90%	174	87%	168	84%	157	79%	147	74%	
	250	200	80%	200	80%	200	80%	200	80%	200	80%	192	77%	185	74%	172	69%	160	64%	
TS630	200	200	100%	200	100%	200	100%	200	100%	200	100%	196	98%	189	95%	178	89%	166	83%	TS800 Busbar Lower & Upper 6t+Heat Sink
	250	250	100%	250	100%	250	100%	250	100%	250	100%	243	97%	236	94%	221	88%	206	82%	
	300	300	100%	300	100%	300	100%	300	100%	300	100%	291	97%	281	94%	264	88%	246	82%	
	400	360	90%	360	90%	360	90%	360	90%	360	90%	348	87%	337	84%	318	80%	305	76%	
TS800	400	400	100%	400	100%	400	100%	400	100%	400	100%	390	98%	378	95%	357	89%	333	83%	TS800 Busbar Lower & Upper 6t+Heat Sink
	500	400	80%	400	80%	400	80%	400	80%	400	80%	387	77%	372	74%	347	69%	322	64%	
	550	440	80%	440	80%	440	80%	440	80%	440	80%	426	77%	409	74%	382	69%	354	64%	
	500	500	100%	500	100%	500	100%	500	100%	500	100%	488	98%	476	95%	446	89%	416	83%	
TS800	550	550	100%	550	100%	550	100%	550	100%	550	100%	532	97%	515	94%	486	88%	453	82%	TS800 Busbar Lower & Upper 6t
	700 *	630	90%	630	90%	630	90%	630	90%	630	90%	619	88%	605	86%	584	83%	563	80%	
	800	640	80%	640	80%	640	80%	640	80%	640	80%	619	77%	605	76%	584	73%	563	70%	
	700 *	700	100%	700	100%	700	100%	700	100%	700	100%	684	98%	665	95%	626	89%	584	83%	
	800	800	100%	800	100%	800	100%	800	100%	800	100%	772	97%	748	94%	700	88%	652	82%	

Note) * Only available for TS800 FTU

Susol MCCB PV up to 800A

Warnings when using Susol MCCB for PV applications

The following warning must be kept when using Susol MCCB for PV applications
When violated, it can cause serious damages on relevant products or incur injuries.



Warning

1. Please use wiring in accordance with the diagrams shown below.

Otherwise, usable voltage may be different from the stated requirement.

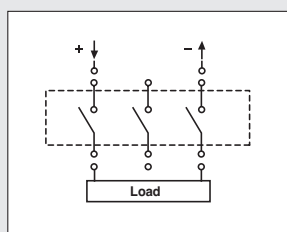

DC500V (2P)

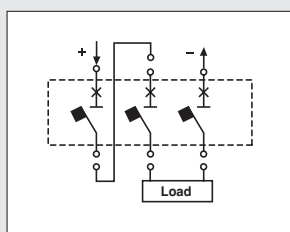

DC750V (3P)

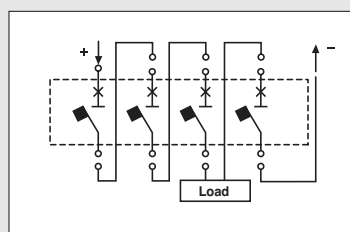

DC1000V (4P)

2. Wire length should be at least 60cm. Shorter wires can cause increase in temperature.
3. De-rated use is highly recommended when designing circuit by using busbar in a manner shown in Figure 1 on the right. If not, it can cause increase in temperature, erroneous trip, damage or fire due to the shortage of heat release(Please refer to the De-rating Table.)
4. Please use thickness and length of busbar in compliance with the specification drawing. When used differently, additional de-rating may be required to release the heat.
5. Use of tin-plated busbar is recommended.
6. Inside of the low voltage panel should not exceed 40°C specified in KS/IEC Standard. Install sun screens or ventilation system if necessary. If violated, it can cause increase in temperature, erroneous trip, damage or fire. Also, additional de-rating is required when the temperature exceeds 40°C.
7. If you have additional questions regarding the application method, please consult with us before the use.

DC MCCB (100~800AF)

Dimensions

TD100, TD160

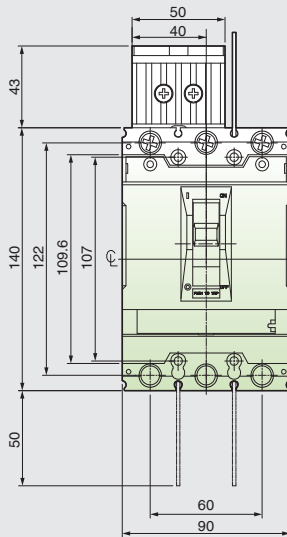

3P

※ R, S Line Common conditions

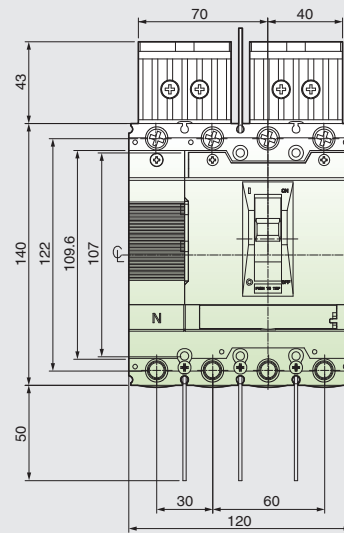

4P (L-type)

TS100, TS160, TS250

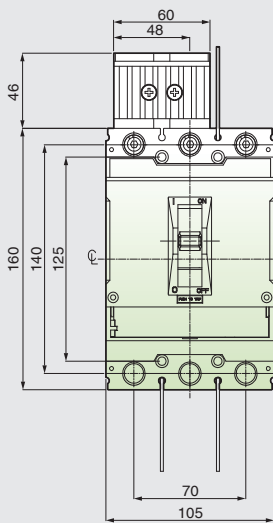

3P

※ R, S Line Common conditions

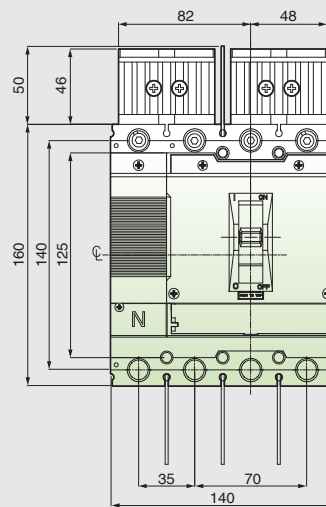

4P (L-type)

※ L-Type and R-Type is symmetric

TS400, TS630

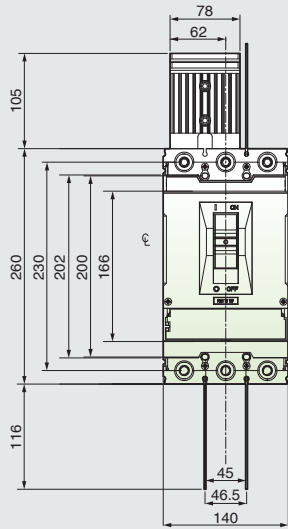

3P

※ R, S Line Common conditions

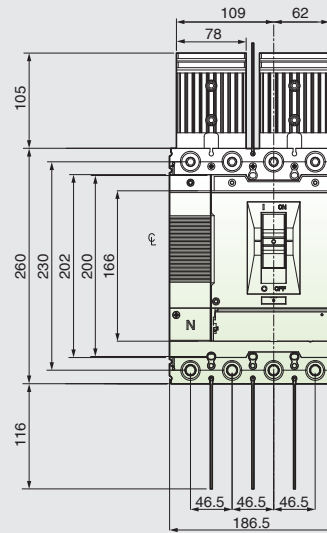

4P (L-type)

※ L-Type and R-Type is symmetric

TS800

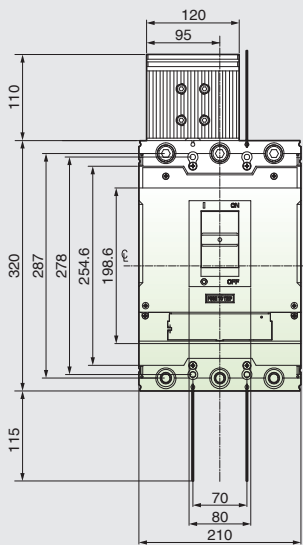

3P

※ R, S Line Common conditions

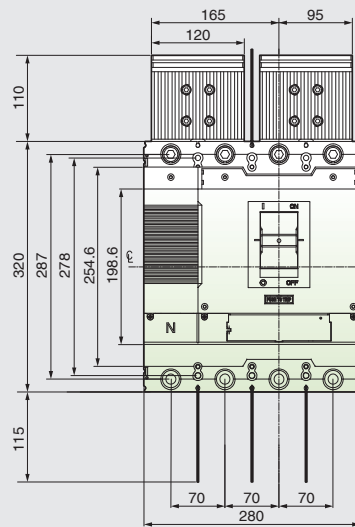

4P (L-type)

※ L-Type and R-Type is symmetric

DC MCCB (DC 1000 / 1500V)

Characteristics

- Applications such as photovoltaic (PV) power generation, UPS and data center.
- Compact size implemented
- Maximum breaking capacity
- Nominal voltage ranges up to 1000/1500Vdc
- Rated current: 63~250A
- No. of poles: 2/4pole



Rating

AF		250AF			
Type		N-Type	N-Type	H-Type	NA-Type
Model		TSD250N	TSD250N	TSD250H	TSD250NA
Pole		2P	4P		
Rated current, In		63**, 80, 100, 125, 160, 200, 250A			200, 250A
Rated operational voltage, Ue		DC 1000V	DC 1500V		
Rated insulation voltage, Ui		DC 1000V	DC 1500V		
Rated impulse withstand voltage, Uimp		8kV			
Rated short-circuit breaking capacity, Icu		20kA	20kA	50kA	I _{cw} * 3kA, I _{cm} * 3kA
I _{cs} = % I _{cu}		100			-
Category		A			
Type of trip unit		Thermal-Magnetic			-
Current range	Fixed (I _r)	1 × I _n			-
Magnetic trip range	Fixed (I _i)	6 × I _n			-
Life cycle (time)	Mechanical	10,000			
	Electrical	2,000			1,000
Dimension (W×H×D, mm)		76 × 170 × 92	140 × 170 × 92		
Standards		IEC/EN60947-2, GB14048.2			IEC60947-3 & Annex D(For PV) GB/T14048.3
Certification		CCC, CB			

* I_{cw}: Rated short-circuit withstand current(kA), 1s

I_{cm}: Rated short-circuit making capacity(kA)

** 63A Magnetic trip range: 8×I_n

Temperature derating

Type	Rated Current (A)			Compensated rated current in accordance with ambient temperature (A)										Terminal Connection
	Rated	Derating		40°C		45°C		50°C		60°C		70°C		
TSD250	63	63	100%	63	100%	62	98%	60	95%	56	89%	52	83%	TSD250 BUSBAR 5T
	80	80	100%	80	100%	78	98%	76	95%	71	89%	66	83%	
	100	100	100%	100	100%	98	98%	95	95%	89	89%	83	83%	
	125	125	100%	125	100%	122	98%	119	95%	111	89%	104	83%	
	160	160	100%	160	100%	155	97%	150	94%	141	88%	131	82%	
	200	200	100%	200	100%	196	98%	190	95%	178	89%	166	83%	
	250	250	100%	250	100%	243	97%	235	94%	220	88%	205	82%	

* Load-side terminal cover using derating current applied to 90%

Altitude derating

Altitude (m)	Ue (Vdc)			250AF
	2P	4P	Compensation constant	
2000	1000V	1500V	1.00	100%
3000	870V	1300V	0.87	98%
4000	770V	1150V	0.77	93%
5000	670V	1000V	0.67	90%

Exclusive external accessories

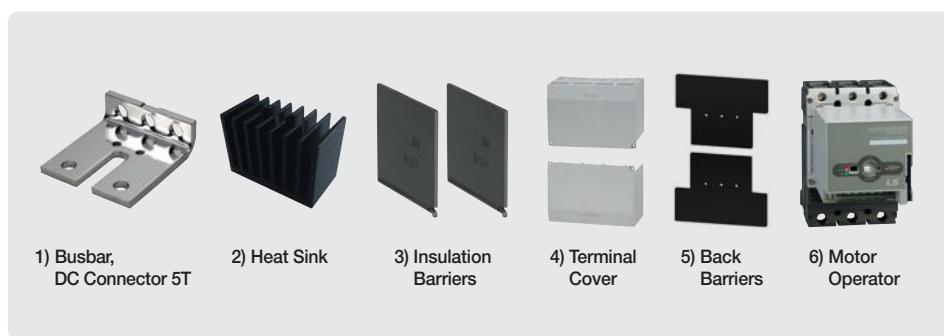

* Exclusive codes required for MOP order

Possible configuration of electrical auxiliaries



UVT



SHT



AX



AL

Maximum possibilities

Phase	Accessory	TSD250
R (Left)	AX	1
	AL	1
	SHT, UVT	1
T (Right)	AX	1
	AL	-

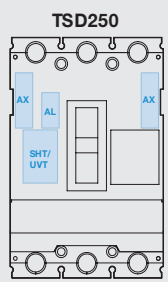

TSD250

Note) 1. The internal accessories are assembled together with the product, so be careful when ordering.
 2. SHT / UVT can not be used simultaneously

DC MCCB (DC 1000 / 1500V)

Wiring diagram

1. Unground system

4Pole

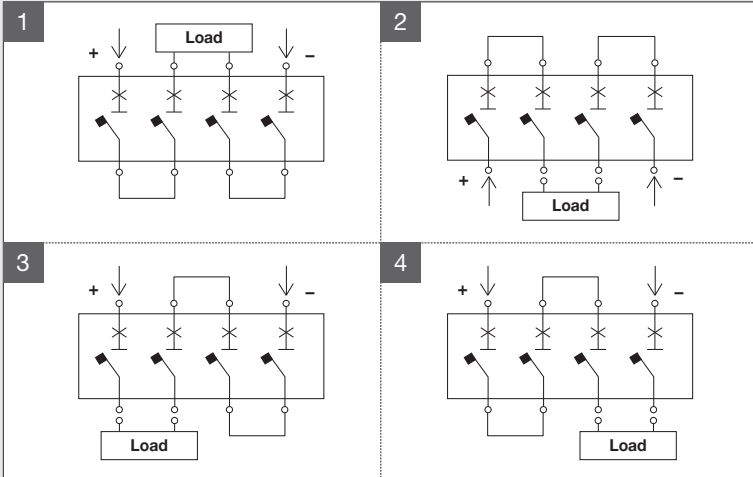

2Pole

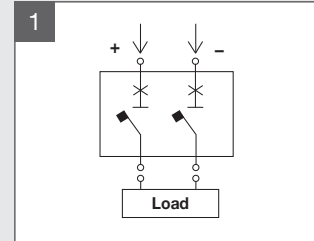

2. Grounded system

4Pole

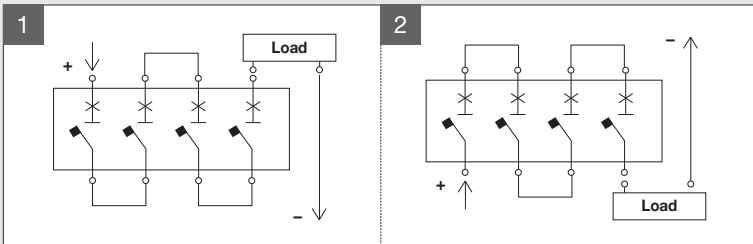

2Pole

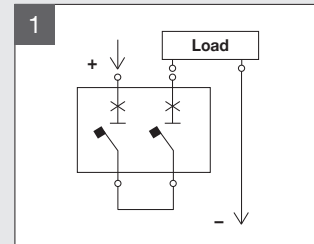

Characteristic curve

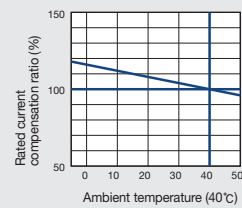
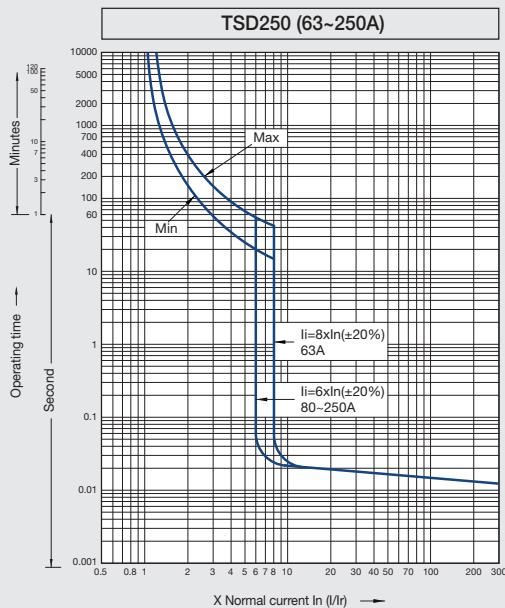

Product installation standards

1. By insulation and separation distance

- One side (30mm or more),
- Up & down (121mm or more)
- Between products (60mm or more)

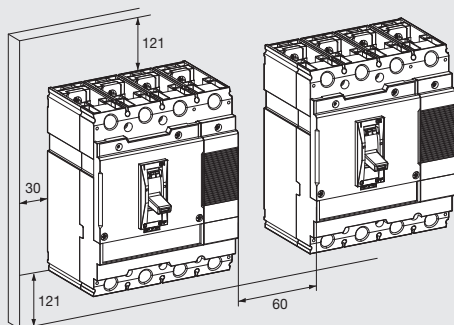

2. Close mounting

- Using barrier between phases

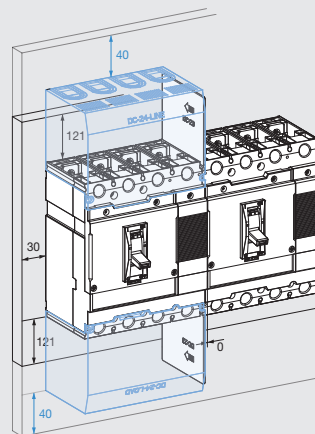

Dimensions

4Pole

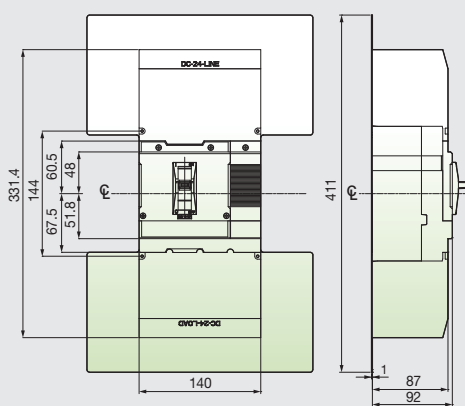
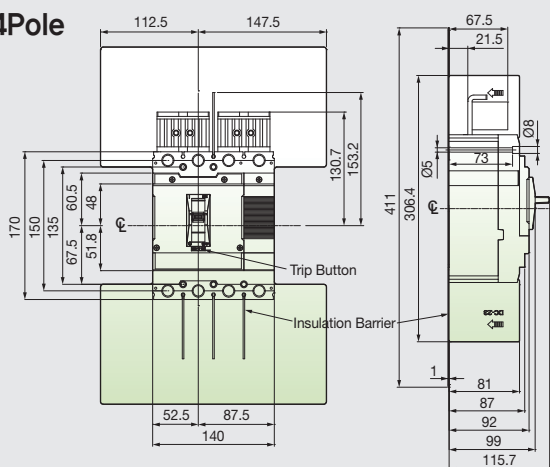

Terminal details

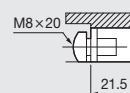
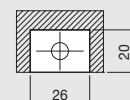

Connecting

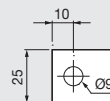

2Pole

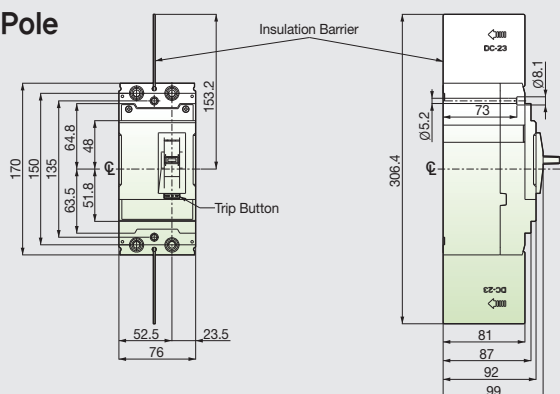

Panel drilling

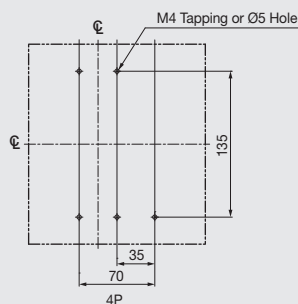

Front panel cutting

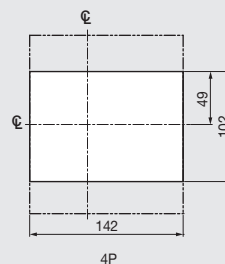

DC Switch-Disconnectors (1600AF)

1600AF Switch-Disconnectors

Characteristics

- 4Pole: DC1150V/AC690V Switch disconnectors
- 3Pole: DC900V/AC690V Switch disconnectors
- 1000/1250/1600A DC
- Uimp = 8kV
- IEC60947-3

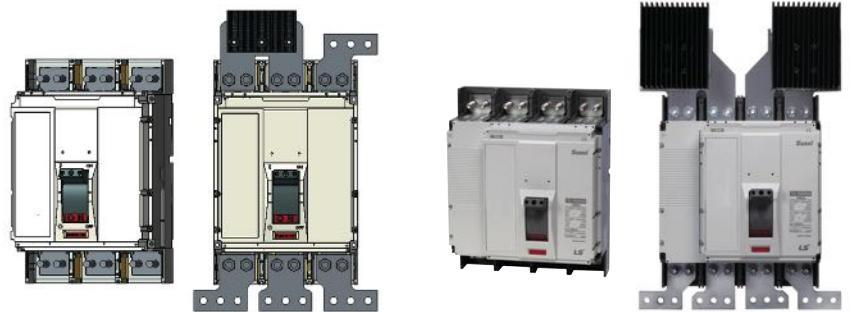

(TS1250NA 3P)

(TS1600NA 4P)

Rating

Type		TS1000NA	TS1250NA	TS1600NA
Frame size	[AF]	1000	1250	1600
Conventional thermal current, Ith	[A]	1000	1250	1600
Rated operational current, Ie	[A]	1000	1250	1600
No. of poles	[Pole]	3/4	3/4	3/4
Rated operational voltage, Ue	DC/AC 3pole [V]	900/690	900/690	900/690
	DC/AC 4pole [V]	1150/690	1150/690	1150/690
Rated insulation voltage, Ui	DC [V]	1150	1150	1150
	AC [V]	1000	1000	1000
Rated impulse withstand voltage, Uimp	[kV]	8	8	8
Rated short-circuit making capacity, Icm	DC [kA peak]	25	25	25
	AC [kA peak]	52.5	52.5	52.5
Rated short-circuit making capacity, Icw	1sec [kA rms]	25	25	25
Utilization category		DC22B/AC23B	DC22B/AC23B	DC22B/AC23B
Isolation behavior		●	●	●
Trip unit (Release)	Disconnector unit DSU	●	●	●
Connection	Fixed	Front-connection	●	●
		Rear-connection	●	●
Mechanical life	[Operations]	10000	10000	10000
Electrical life	@ V DC [Operations]	500	500	500
	@ 690V AC [Operations]	2000	2000	2000
Dimensions without accessories, WxHxD (Front connection)	3pole [mm]	210×327×152.5	210×327×152.5	210×327×152.5
	4pole [mm]	280×327×152.5	280×327×152.5	280×327×152.5
Weight without accessories (Front connection)	3pole [kg]	12	12	12
	4pole [kg]	17.8	17.8	17.8
Reference standard		IEC60947-3	IEC60947-3	IEC60947-3

Accessories

1) For TS1000NA DC

2) For TS1250NA DC

3) For TS1600NA DC

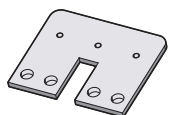

<Busbar>

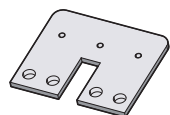

<Busbar>



<Heatsink>



<Busbar>



<Heatsink>

Dimensions

TS1600NA

Dimension of MCCB with DC BUSBAR

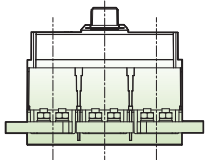
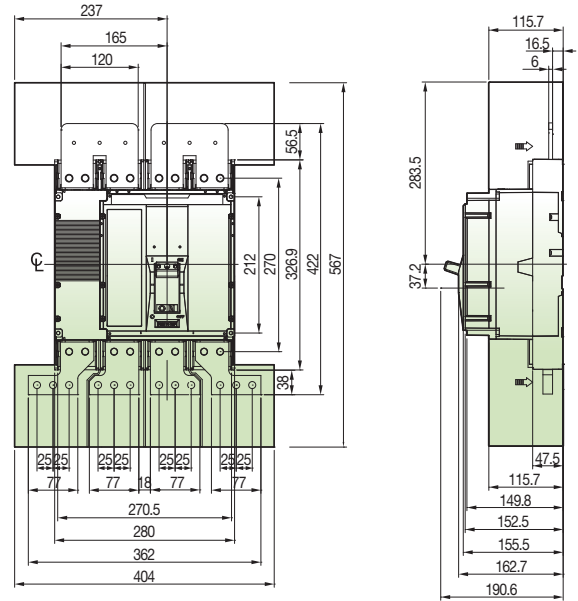
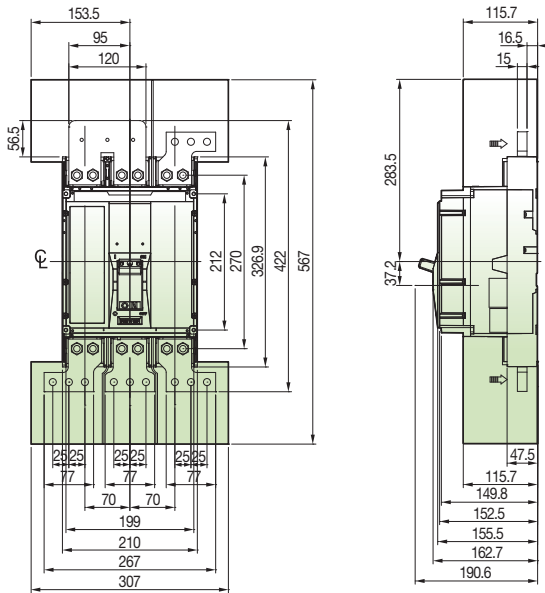

<TS1000NA 3P>

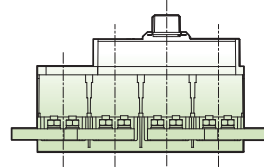

<TS1000NA 4P>

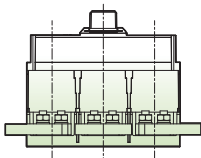
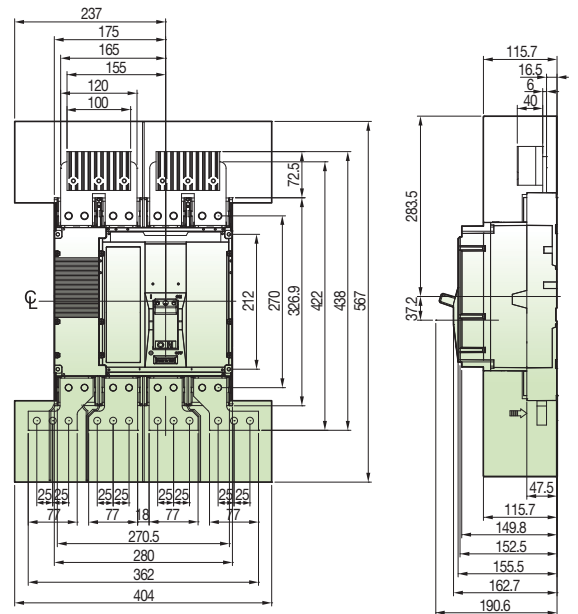
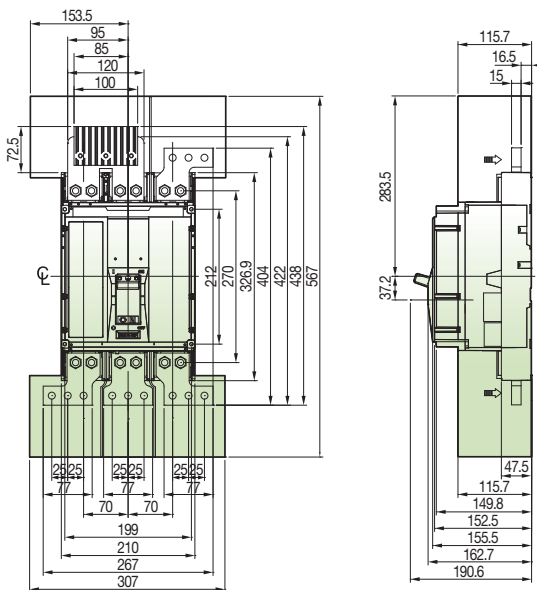

<TS1250NA 3P>

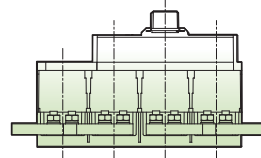

<TS1250NA 4P>

DC Switch-Disconnectors (1600AF)

Dimensions

TS1600NA

Dimension of MCCB with DC BUSBAR

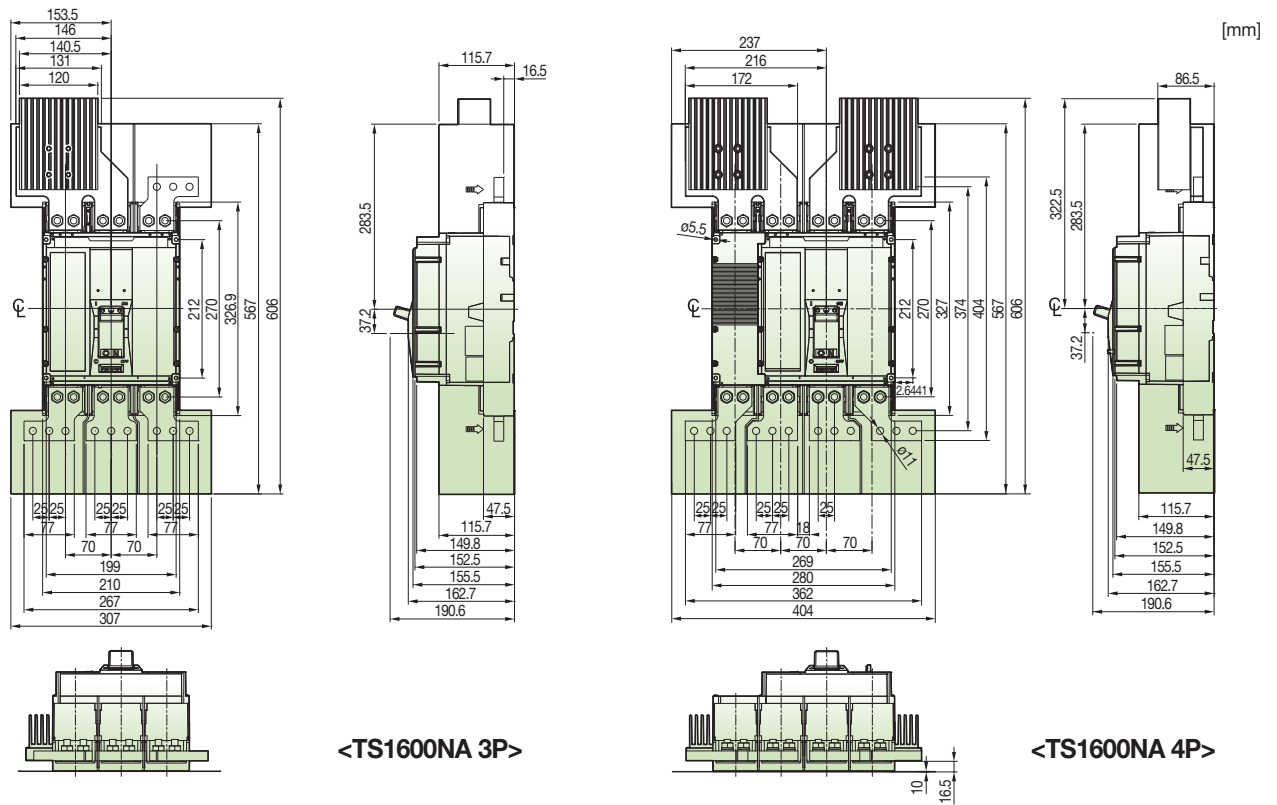

Connection diagrams

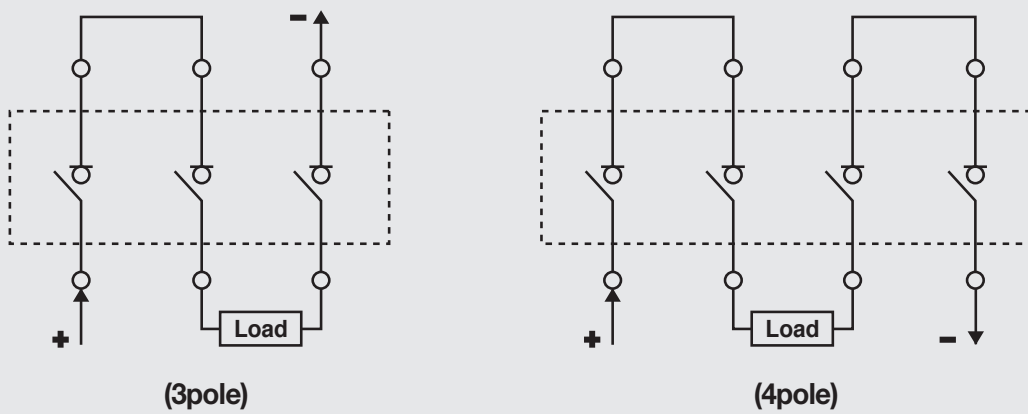

Dimensions

Panel drilling

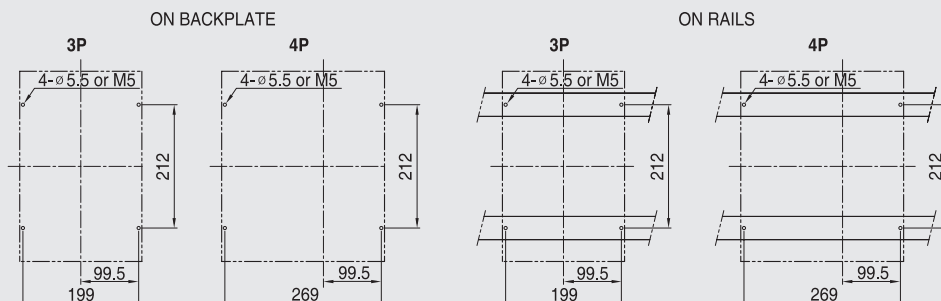

Front panel cutting

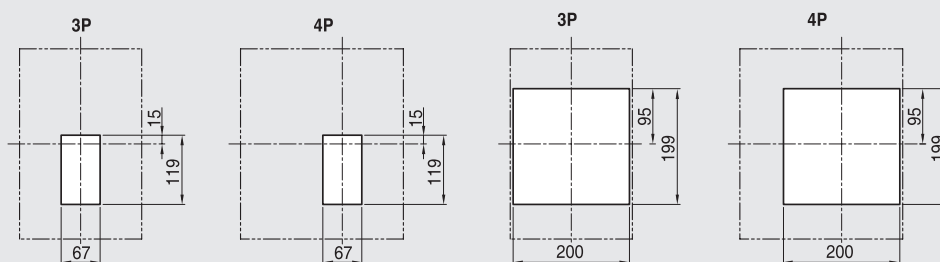

TS1000NA/TS1250NA Short BUSBAR dimension

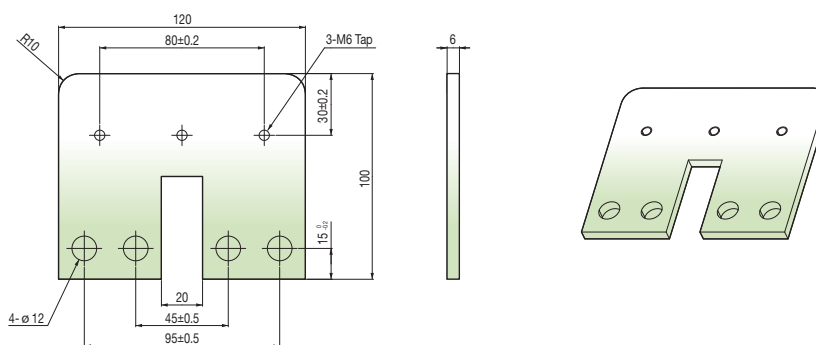

TS1600NA Short BUSBAR dimension

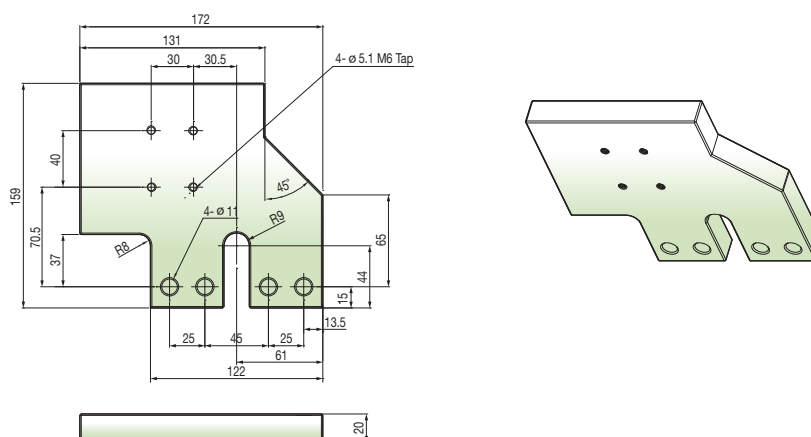

DC MCB

Characteristics

- Solar power, renewable suitable for DC power source
- SEMKO CB
- Maximum working voltage: DC1,000V
- Rating and number of poles: 1~63A, 1/2/3/4 pole
- Rated voltage: DC250/500/750/1000V
- Rated breaking capacity: 10kA
- Trip characteristic: B, C
- Accessorys: AX, AL, SHT



Rating



ON / OFF
Display Indicator



AX, AL



SHT, UVT

Type		
Frame size		
No. of poles		
Rated current, I _n		
Rated operational voltage, U _e DC	Reference standard IEC 60947-2, Icu	Poles Rated voltage Breaking current
Rated insulation voltage, U _i AC		
Rated impulse withstand voltage, U _{imp} AC		
Trip characteristic		
Protection		
Endurance life (times)	Electrical	
	Mechanical	
Degree of protection		
Tightening torque		
Installation		
Type of Terminal		
Type of trip		
Ambient temperature		
Approval		

BK63H DC			
63AF			
1P, 2P, 3P, 4P			
1, 2, 3, 4, 6, 10, 16, 20, 25, 32, 40, 50, 63A			
1P	2P	3P	4P
250V	500V	750V	1000V
10kA	10kA	10kA	10kA
500V			
6kV			
B (5In), C (8In)			
Overload and short circuit			
1,500			
20,000			
IP20			
18-4 AWG (0.75 ... 25mm ²) / 20 Kgf.cm			
Mounting on 35mm DIN rail			
Lug type			
Thermal-Magnetic			
40°C (Standard), -25~ + 55°C (Use)			
CE, SEMKO, CB			

DC Type connection wiring diagram

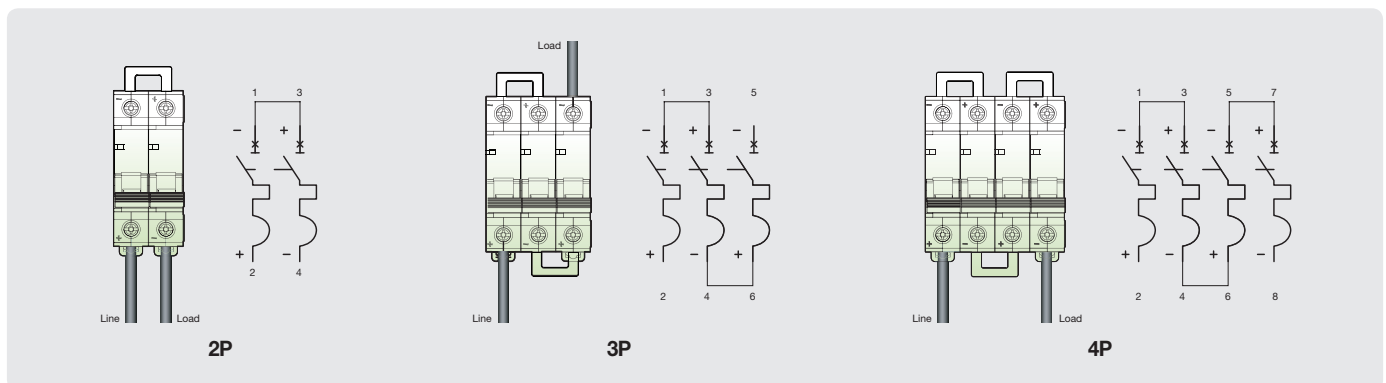

Accessory

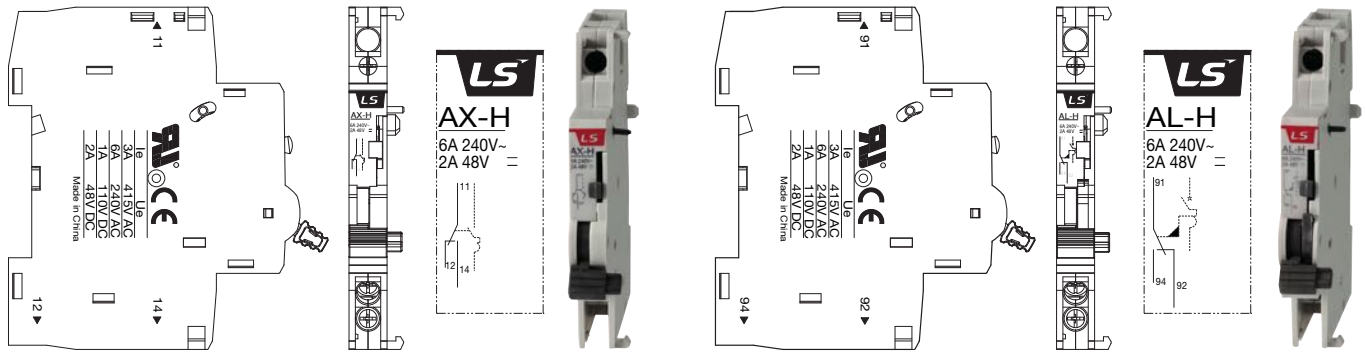

Type	AX-H	AL-H	SHT-H
Appearance			
Rated Operational Current (A)	AC 6A@240V / 3A@415V		DC 24-220V, AC 110-380V
	DC 6A@24V / 2A@48V / 1A@125V		
Working voltage	-		85%-110%Ue
Mechanical Endurance	10,000		-
Cable capacity	0.75~2.5mm ²		≤ 2.5mm ²
Contact			-
Weight (g)	48	48	100

* 24V only SHT product. Please note when ordering.

Dimensions

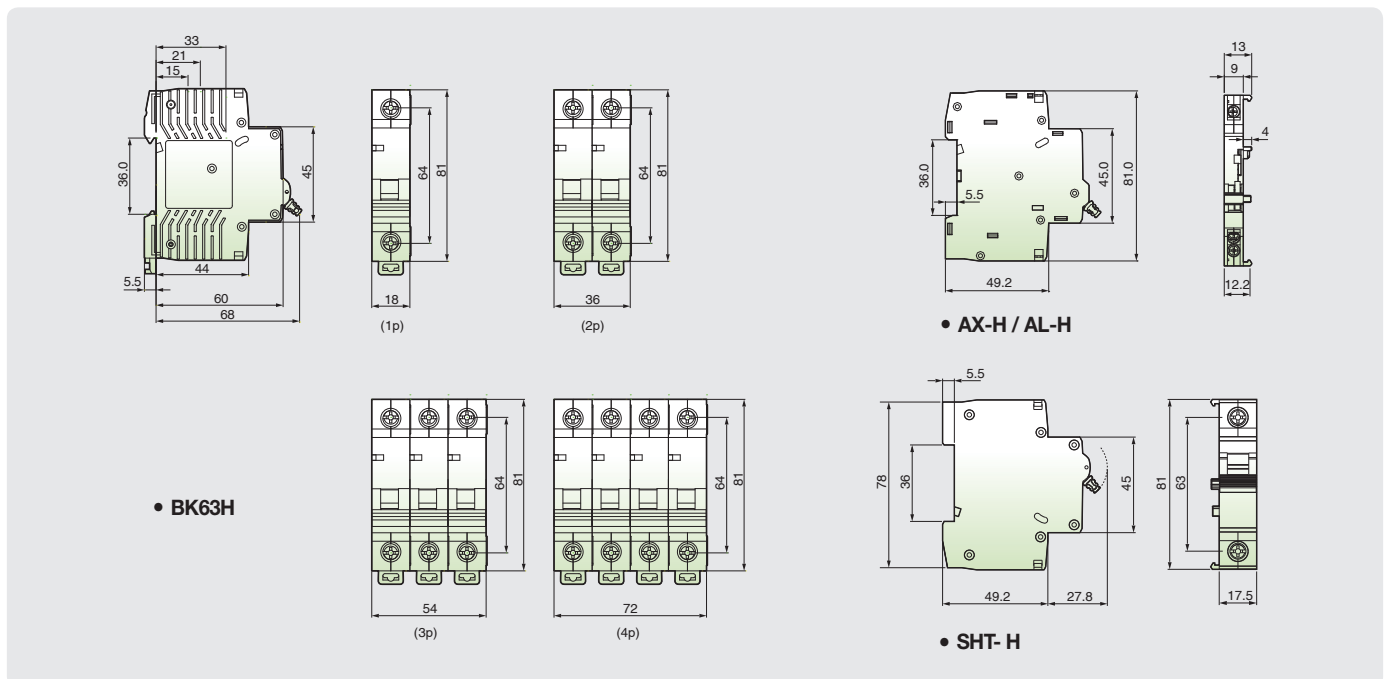

DC Contactors

Characteristics

Products application & Function

- Two normally open main contacts for DC circuit
- Positive and negative poles indicated on the front plate
- Eternal magnet installed for the effective arc extinguishing
- DIN rail or screw mountable
- 2NO+2NC Auxiliary contacts built-in as standard
- AC/DC control voltage
- CE, UL Certified



Selection

Contactor types	DC-2~5 ratings			DC-1	Continuous current, I _{th}	Auxiliary contacts
	125V	250V	500V	1000V		
MD-30a	3.7kW 40A	5.5kW 30A	7.5kW 20A	10A	60A	2a(NO)+2b(NC)
MD-60a	7.5kW 80A	11kW 60A	15kW 40A	25A	100A	2a(NO)+2b(NC)
MD-100a	11kW 120A	18.5kW 100A	22kW 60A	35A	135A	2a(NO)+2b(NC)

Ratings of auxiliary contacts

UA-1	AC15 duty						DC13 duty				
	120V	240V	380V	480V	500V	600V	125V	250V	400V	500V	600V
Rated currents	6A	3A	1.9A	1.5A	1.4A	1.2A	1.1A	0.55A	0.31A	0.27A	0.2A
Continuous current, I _{th}	16A										

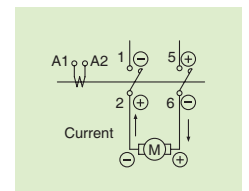

Coil voltage

AC	50/60Hz	24, 48, 100, 110, 120, 200, 220, 230, 240, 380, 400, 415, 440, 500, 550V
DC	DC	12, 20, 24, 48, 60, 80, 100, 110, 125, 200, 220, 250V

Dimensions

MD-30a AC(DC)

2NO2NC

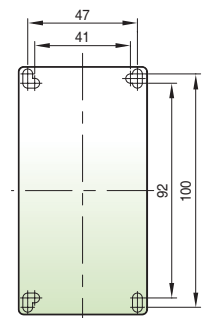
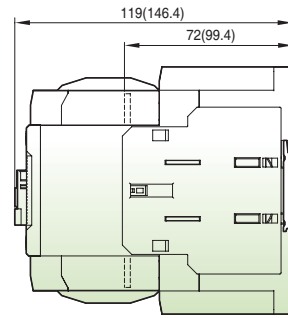
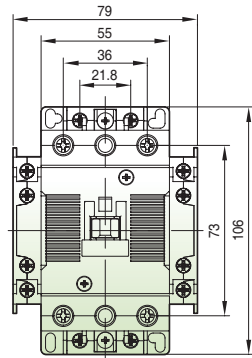

[mm]

MD-60a,100a AC(DC)

2NO2NC

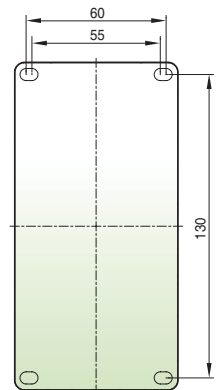
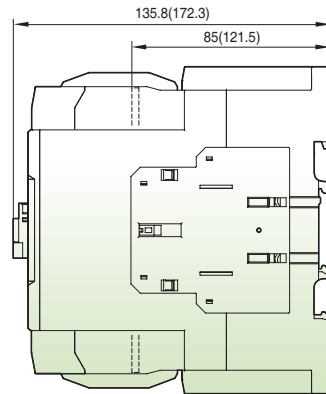
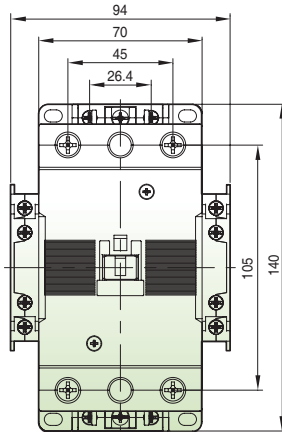

Composition

MD-30a, 60a, 100a

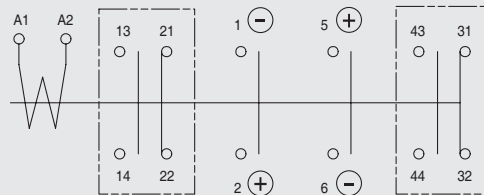

Contact arrangement

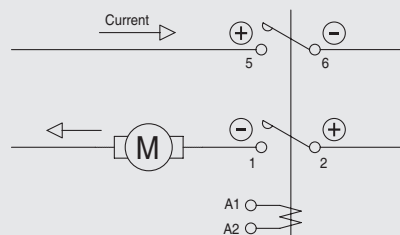

BK Series (DC/DIN type)

Characteristics

- DC system surge voltage protection
- Rating: ~ DC 1500V
- Pole: 2P, 3P
- Grades: Class II
- Status indication
 - Steady state: Green
 - After the accident: colorless (black)



Rating

Type	DC Type				
	BK20S-DC110	BK20S-DC600	BK20S-DC1000	BK20S-DC1500	
No. of poles	[Pole] 2P		3P		
Rated voltages	Un [V] DC110	DC600	DC1000	DC1500	
Max. continued-operation voltage	Uc [V] DC220	DC700	DC1200	DC1500	
Voltage protection level	Up [kV] ≤1.0	≤2.5	≤3.9	≤4.5	
Nominal discharge current	In [kA] 20	20	20	20	
Max. discharge current	I _{max} [kA] 40	40	40	40	
Impulse current	I _{imp} [kA] -	-	-	-	
Grades	Test Class	Class II			
Reaction time		< 25ns			
Status indication		Have Status indication			
Operating temperature range		-40℃~80℃			
Cross-sectional area of the connecting		6mm ² or more			
Accessories		AL ^{Note1)}			
Standard		IEC 61643-11 / UL1449			
Certification		CE	CE, UL	CE, UL	CE
SPD Disconnector	MCCB	TD100 2P 32A	TD100 3P 32A	TD100 4P 32A	TSD250N/H 4P 63A
	MCB	BK63H-DC 2P 40A	BK63H-DC 3P 40A	BK63H-DC 4P 40A	-

Note) 1. The AL contact accessories are not sold separately. You need to choose these accessories when you place your order for the product. Please be mindful of this fact when you place your order.



Dimensions

BK20S-DC

[Unit : mm]

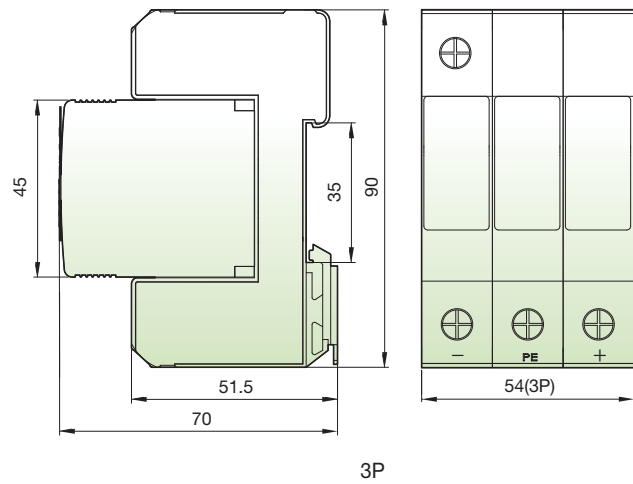
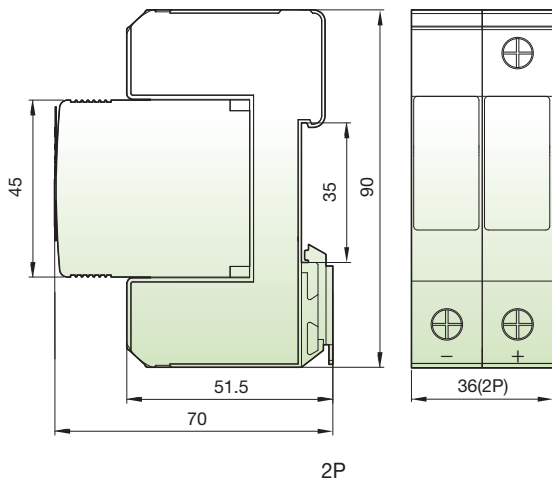

Installation wiring method

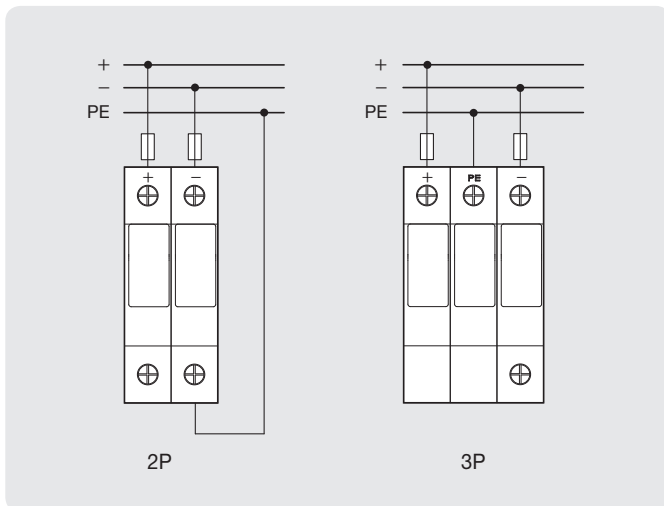

Wiring Diagram

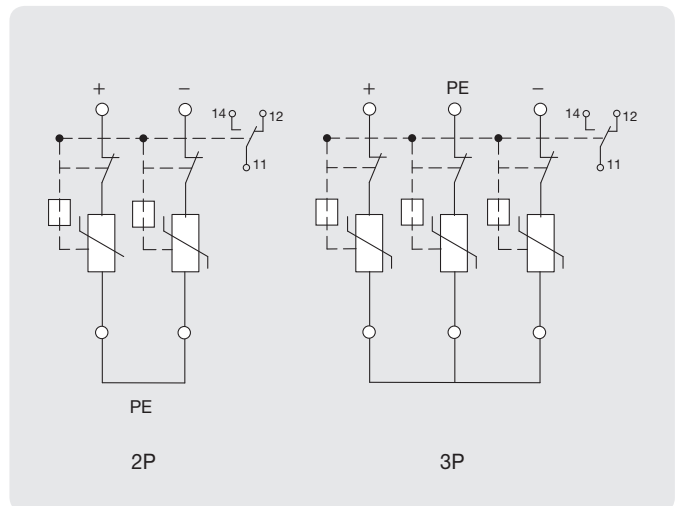

DC ACB

- Basic rating
 - Rated voltage: 1500Vdc (4p) / 1000Vdc (3p) - Rated current: 800 ~ 3200A
 - Short-time capacity: 65kA/1sec - Breaking capacity: 70kA @ 750Vdc, 60kA @ 1500Vdc
- Multi-function relays dedicated to DC protect and enhancing user convenience
 - Precise measurement of current, voltage, power and various protection relay functions
 - Self diagnosis function, event and fault waveform recording
- Electrical endurance:
 - 10,000 operations (1600A @ 1500Vdc), 3,000 operations (3200A @ 1500Vdc)
- Isolation function convenient for withstand voltage test of switchgears
- Optional Short-Busbar considering temperature performance
- Compatible with existing Susol ACB
 - Accessories including closing and trip coils
 - Physical sizes for installation
- Applicable standards and tests: IEC 60947-2, DEKRA CB certification



Type and ratings

Type		DC 1200V						DC 1500V							
Number of poles	(P)	3 / 4						3 / 4							
Rated operational voltage (Ue)	(Vdc)	750 (3P) / 1200 (4P)						1000 (3P) / 1500 (4P)							
Rated insulation voltage (Ui)	(V)	1500						1500							
Rated impulse withstand voltage (Uimp)	(kV)	12kV						12kV							
Version		Fixed / Withdrawable						Fixed / Withdrawable							
Suitability for isolation		— — X —						— — X —							
Degree of pollution	IEC60661-1	3						3							
Certification		CB certification according to IEC 60947-2						CB certification according to IEC 60947-2							
Brand name		Susol						Susol							
Ampere Frame		ADH-08E 800AF	ADH-10E 1000AF	ADH-13E 1250AF	ADH-16E 1600AF	ADH-20E 2000AF	ADH-25E 2500AF	ADH-32E 3200AF	ADV-08E 800AF	ADV-10E 1000AF	ADV-13E 1250AF	ADV-16E 1600AF	ADV-20E 2000AF	ADV-25E 2500AF	ADV-32E 3200AF
Rated current (In) at 40°C	(A)	400, 630, 800	630, 800, 1000	630, 800, 1000, 1250	800, 1000, 1250, 1600	1600, 2000	1600, 2000, 2500	1600, 2000, 2500, 3200	400, 630, 800	630, 800, 1000	630, 800, 1000, 1250	800, 1000, 1250, 1600	1600, 2000, 2500	1600, 2000, 2500, 3200	
Rated ultimate breaking capacity (Icu)	(3P)	500V DC	60			85			-						
		750V DC	40			-			60			70			
	1000V DC	-			-			50			60				
	(4P)	750V DC	50			-			-						
		1000V DC	-			-			60			70			
Rated service breaking capacity (Ics)	(4P)	1200V DC	35			40			-						
		1500V DC	-			-			50			60			
		1500V DC	-			-			50			60			
Rated short-time withstand current (Icw)	(3P)	500V DC	60 ^{Note1)}			65			-						
		750V DC	40			40			50 ^{Note1)}			60			
		1000V DC	-			-			50 ^{Note1)}			50			
	(4P)	750V DC	50 ^{Note1)}			50			-						
		1000V DC	-			-			50 ^{Note1)}			65			
		1200V DC	35			40			-			-			
Rated making capacity (Icm)	(kA peak)	1500V DC	-			-			50 ^{Note1)}			50			
		1500V DC	100			100			100						
Utilization category (according to IEC 60947-2)		B						B							
Overcurrent protection	Electronic trip units for DC applications	●						●							
Operation time	Total Breaking < Icw	(ms)						Less than 25ms under Icw/ Less than 75ms over Icw							
	> Icw	(ms)						Less than 25ms under Icw/ Less than 75ms over Icw							
	Closing time	(ms)						80ms under							
Mechanical and Electrical Life cycle															
Endurance (times) (Without maintenance)	Mechanical	(times)	15,000						15,000						
		lessw than 1600A	(times)						10,000						
	Electrical (at 1000 V DC)	2000A	(times)						8,000						
		2500A	(times)						-						
Demension and Weight															
Weight (3P/4P)	Drawout	Without cradle	(kg)						43 / 53						
		With cradle	(kg)						87 / 103						
	Fixed	(kg)						44 / 55							
External dimensions (H×W×D)	Drawout	3P(4P)	(mm)						430×412(527)×375						
		3P(4P)	(mm)						300×378(493)×295						

Note 1) Duration of rated short-time withstand current (Icw) is 0.5s

Connection diagram of DC ACB

ADV	750V	1000V	1500V
ADH	500V	750V	1200V

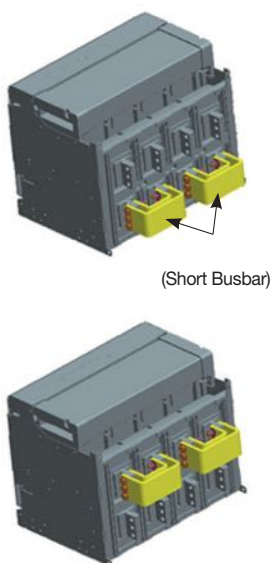

Upper supply

Lower supply

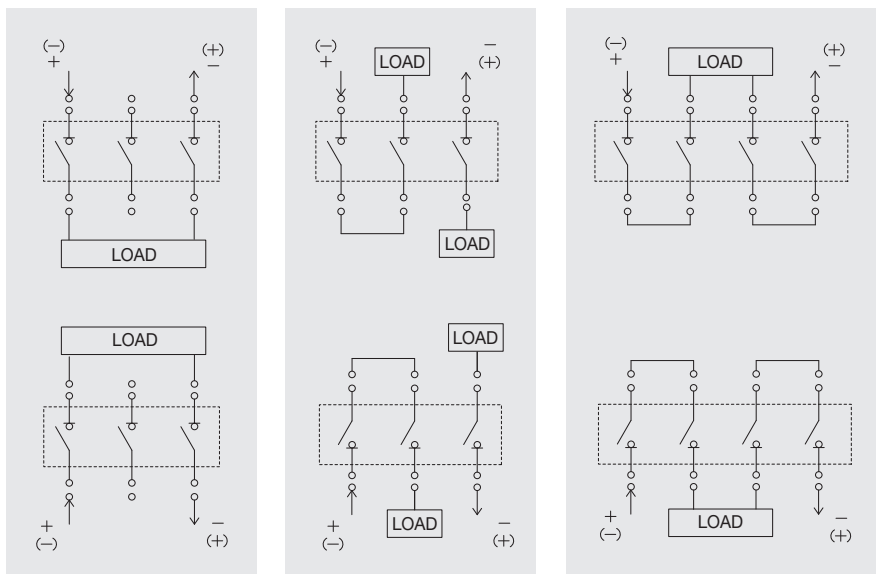

※ Refer to the following page for product dimensions with short busbar.

Composition of short busbar

1. Short busbars can be ordered as shown in the table below, or customer have to make short busbars in accordance with the specified short busbars according to AF.
2. The tightening torque for assembling short busbars is 40~50N.m

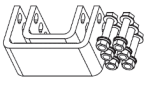
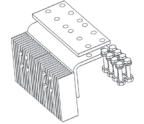
Type	AF	Qty. of code	Aspects	Parts (3P)
ADH ADV	E : ~2500AF	70223464603 3P : 1ea 4P : 2ea		Short busbars : 75mm × 10T × 2ea Bolt : M12 × 60, 6ea Nut : M12, 6ea Spring washer, Plain washer
ADH ADV	E : 3200AF	70223464620 3P : 1ea 4P : 2ea		Short busbars : 100mm × 10T × 1ea 120mm × 105mm × 10T × 1ea (L type) Bolt : M12 × 60, 8ea Nut : M12, 8ea Spring washer, Plain washer, Heat sink

DC Switch-Disconnectors

- Basic rating
 - Rated voltage: 1500Vdc (DDV type), 1200Vdc (DDH type)
 - Rated current: 800 ~ 4000A - I_{cw} = 100kA / 1s
 - Utilization Category: DC-23A
- Electrical endurance:
 - 10,000 operations (1600A @ 1500Vdc)
 - 2,000 operations (4000A @ 1500Vdc)
- Optional Short-Busbar considering temperature performance
- Compatible with existing Susol ACB
 - Accessories including closing and trip coils
 - Physical sizes for installation
- Applicable standards and tests: IEC 60947-3, DEKRA CB, UL listed certification



Type and ratings

Specification		Electrical characteristics														
		DDH/DDV-20D							DDH/DDV-40E							
Rated insulation voltage (U _i)	(Vdc)	1500														
Rated impulse withstand voltage (U _{imp})	(kV)	12														
Rated short-time withstand current (I _{cw})	(kA/1s)	100 ¹⁾							100							
	(kA/0.4s)	100														
Rated making capacity (I _{cm})	(kA, peak)	100														
Operation time (ms)	Opening	Less than 25ms under I _{cw} /Less than 75ms over I _{cw}														
	Closing	80ms under														
Version	Draw-out type	●														
	Fixed type	●														
Standard certification		DEKRA CB certification according to IEC 60947-3														
DC1200V		DDH							DDH							
Type		DDH-08D	DDH-10D	DDH-13D	DDH-16D	DDH-20D		DDH-08E	DDH-10E	DDH-13E	DDH-16E	DDH-20E	DDH-25E	DDH-32E	DDH-40E	
Frame size (AF)		800	1000	1250	1600	2000		800	1000	1250	1600	2000	2500	3200	4000	
Rated operational voltage (U _e)	3Pole (V DC)	750							750							
	4Pole (V DC)	1200							1200							
Utilization category (according to IEC 60947-3) ⁴⁾		DC-22A							DC-22A							
Endurance (times) (Without maintenance)	Mechanical	20,000							15,000							
	Electrical Time const 2ms	6,000	5,000	2,500	1,500	1,000		3,000			2,000		1,000			
DC1500V		DDV							DDV							
Type		DDV-08D	DDV-10D	DDV-13D	DDV-16D	DDV-20D	DDV-25D	DDV-08E	DDV-10E	DDV-13E	DDV-16E	DDV-20E	DDV-25E	DDV-32E	DDV-40E	
Frame size (AF)		800	1000	1250	1600	2000	2500	800	1000	1250	1600	2000	2500	3200	4000	
Rated operational voltage (U _e)	3Pole (V DC)	1000 (1200V) ²⁾							1000 (1200V) ²⁾							
	4Pole (V DC)	1500							1500							
Utilization category (according to IEC 60947-3)		DC-23A							DC-23A							
Endurance (times) (Without maintenance)	Mechanical	20,000							15,000							
	Electrical ³⁾	Time const 7.5ms	-	-	-	-	-	-	5,000			4,000	2,500	1,500	1,000	
		Time const 2ms	9,000	6,000	4,000	2,000	1,500	1,000	10,000			8,000	5,000	3,000	2,000	
Demension and weight																
Weight (3P/4P)	Without cradle	Draw-out type	(kg)	34/42				37/45	43/53							
	With cradle		(kg)	63/74				70/85	87/103							
	Fixed type	(kg)	34/44				38/47	44/55								
External dimensions (H×W×D)	Draw-out type	(mm)	430×334(419)×375							430×412(527)×375						
	Fixed type	(mm)	300×300(385)×295							300×378(493)×295						

1) DDH/DDV-20D is 100kA/0.4s
 2) DDV 3Pole models can be used up to DC 1200V, but if the voltage exceeds DC 1000V, please contact us.
 3) Electrical endurance is reduced to 50% at time constant exceeding 2ms.
 4) Since Utilization category DC-22A is applied, it can not be used for DC circuit with time constant exceeding 2ms.

Connection diagram of DC ACB

DDH	500V	750V	1200V
DDV	500V	1000V	1500V

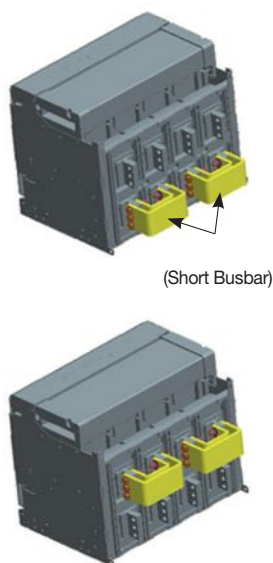

Upper supply

Lower supply

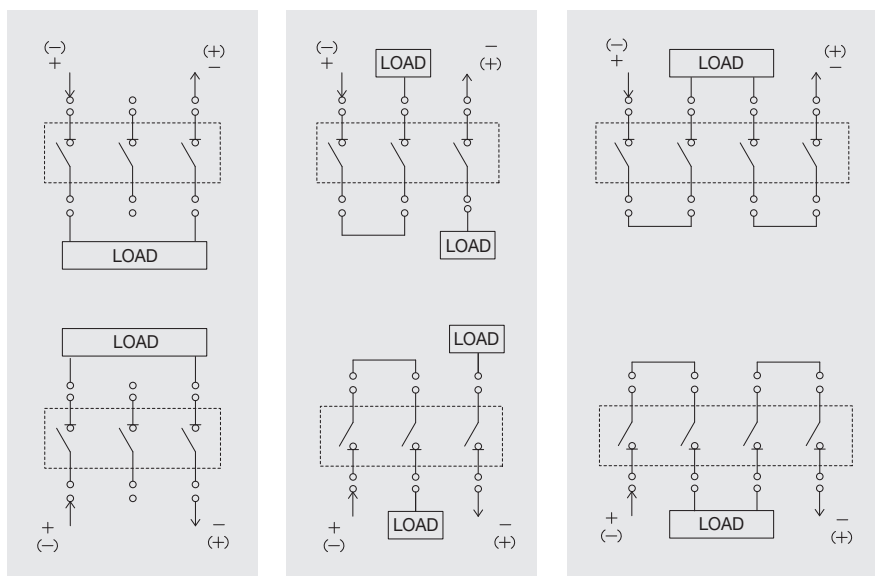

※ Refer to the following page for product dimensions with short busbar.

Composition of short busbar

- Short busbars can be ordered as shown in the table below, or customer have to make short busbars in accordance with the specified short busbars according to AF.
- The tightening torque for assembling short busbars is 40~50N.m

Type	AF	Qty. of code	Aspects	Parts (3P)
DDH DDV	E : ~3200AF	70223464603 3P : 1ea 4P : 2ea		Short busbars : 75mm×10T×2ea Bolt : M12×60, 6ea Nut : M12, 6ea Spring washer, Plain washer
DDH DDV	E : 4000AF	70223464604 3P : 1ea 4P : 2ea		Short busbars : 125mm×10T×3ea Bolt : M12×80, 6ea Nut : M12, 6ea Spring washer, Plain washer
DDH DDV	D : 1600AF	70223461600 3P : 1ea 4P : 2ea		Short busbars : 135mm×100mm×10T×1ea (L type) Bolt : M12×45, 4ea Nut : M12, 4ea Spring washer, Plain washer
DDH DDV	D : 2000AF	70223461601 3P : 1ea 4P : 2ea		Short busbars : 135mm×100mm×10T×1ea (L type) Bolt : M12×45, 4ea Nut : M12, 4ea Spring washer, Plain washer, Heat sink
DDV	D : 2500AF	70223461602 3P : 1ea 4P : 2ea		Short busbars : 125mm×10T×1ea Bolt : M12×45, 6ea Nut : M12, 6ea Spring washer, Plain washer, Heat sink

Dimensions

Fixed type (DDH/DDV-08~20D)

(Unit : mm)

Front view

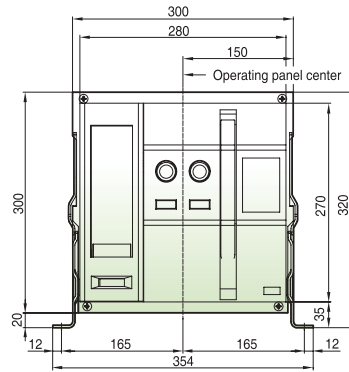

3P

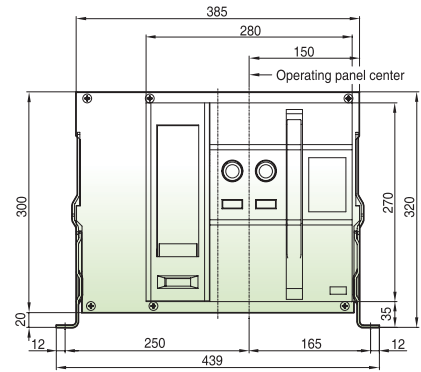

4P

Vertical type

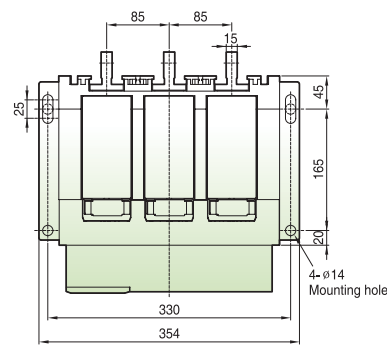

3P

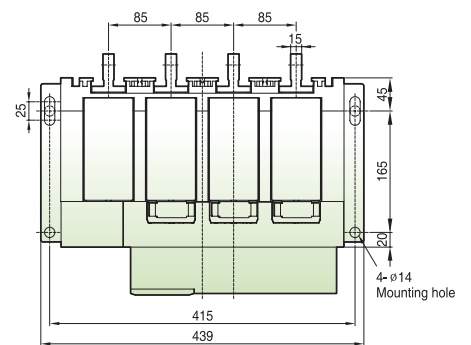

4P

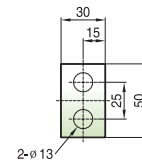
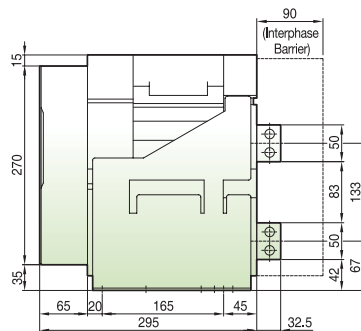

<Conductor>

Fixed type (DDH/DDV-08~20D)

(Unit : mm)

Horizontal type

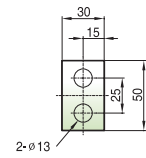
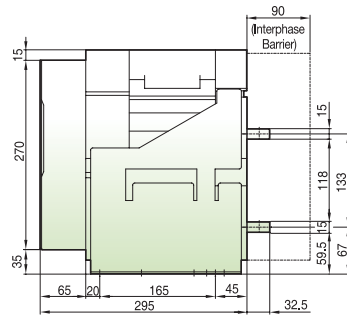
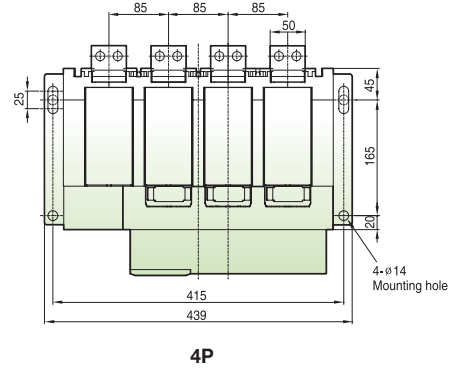
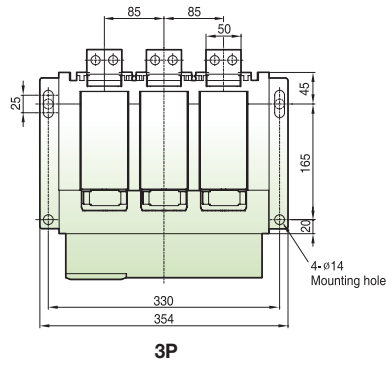

<Conductor>

Front connection type

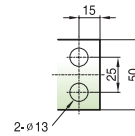
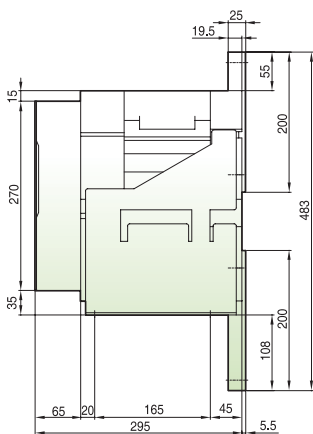
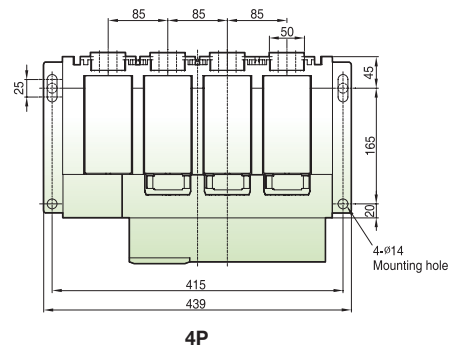
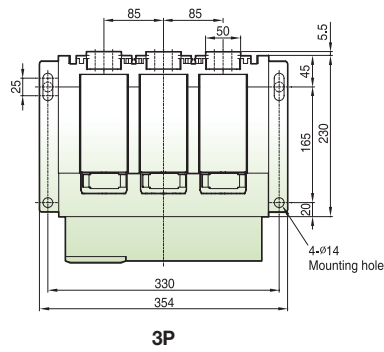

<Conductor>

Dimensions

Fixed type (DDH/DDV-25D)

(Unit : mm)

Front view

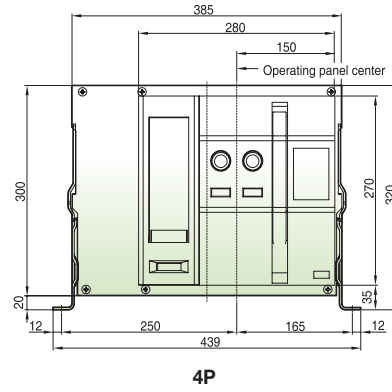
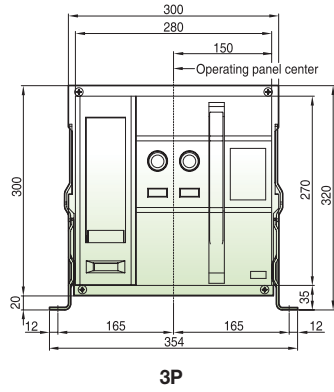

Vertical type

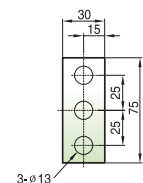
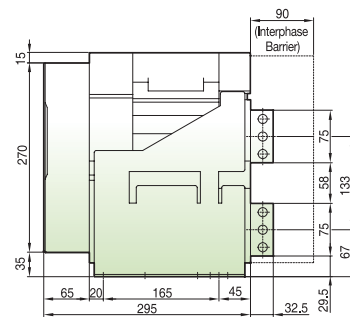
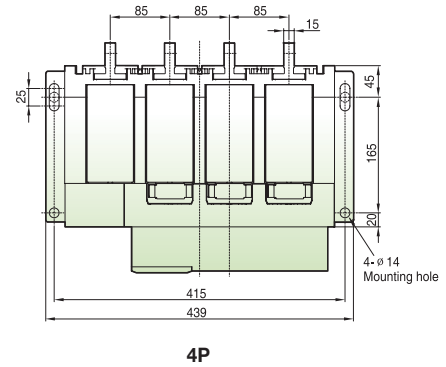
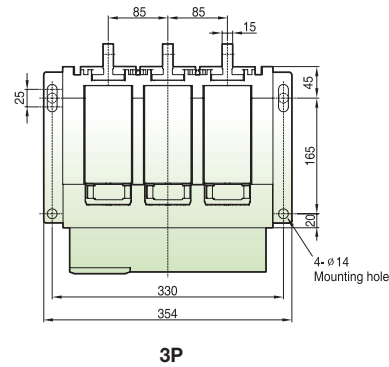

<Conductor>

**Fixed type
(ADH/ADV-08~25E, DDH/DDV-08~32E)**

(Unit: mm)

Front view

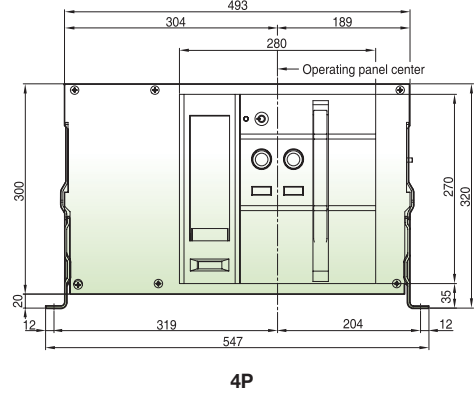
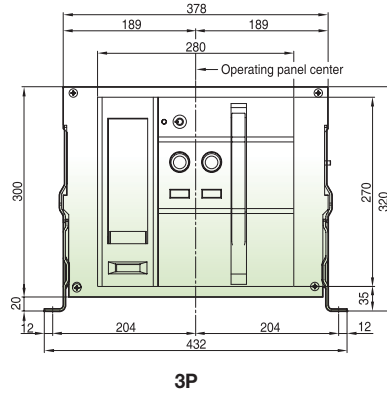

Vertical type

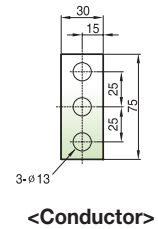
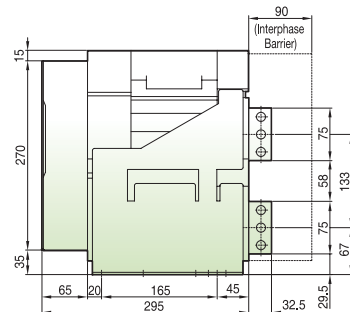
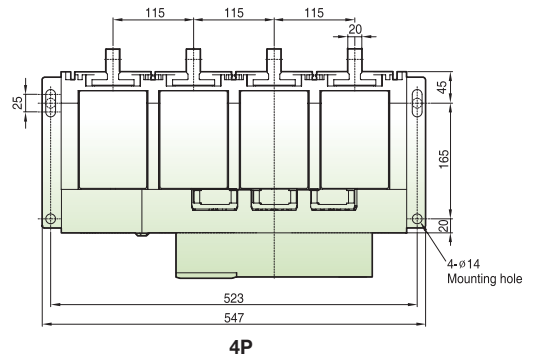
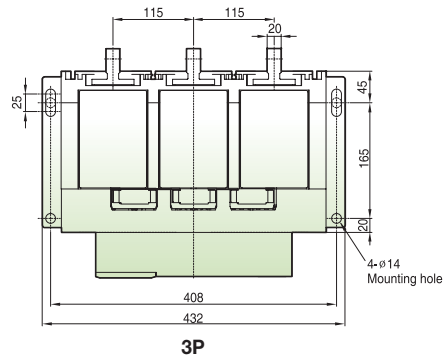

Dimensions

Fixed type (ADH/ADV-08~16E, DDH/DDV-08~32E)

(Unit : mm)

Horizontal type

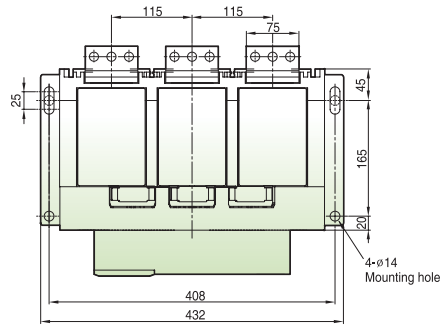

3P

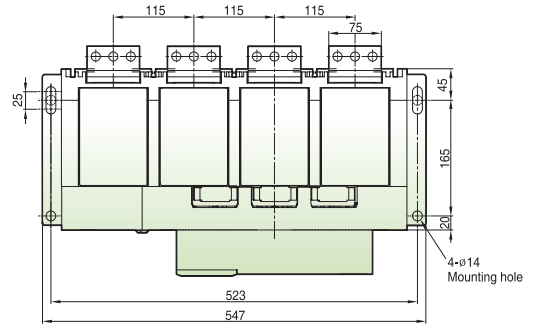

4P

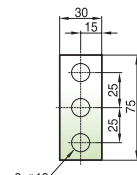
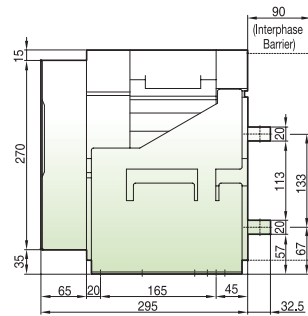

<Conductor>

Front connection type

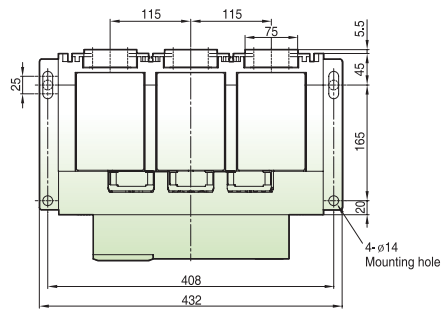

3P

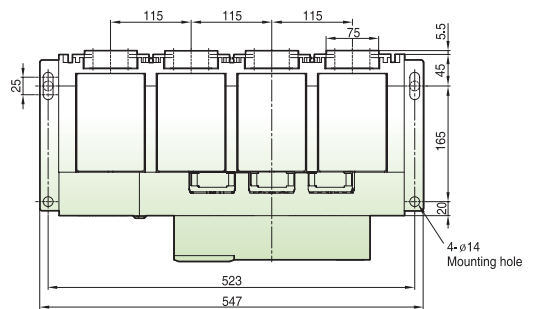

4P

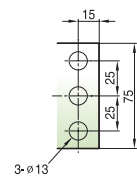
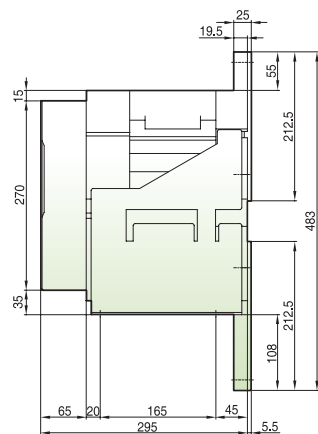

<Conductor>

Fixed type (ADH/ADV-32E)

(Unit : mm)

Front view

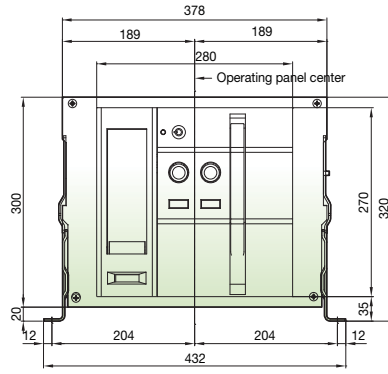

3P

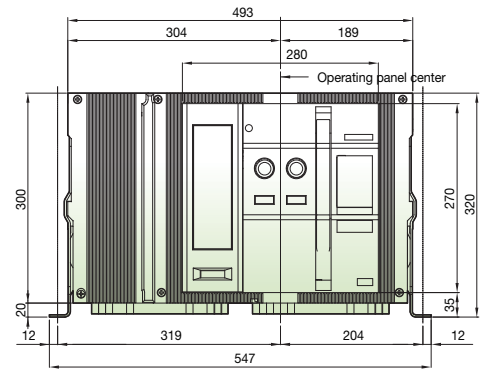

4P

Vertical type

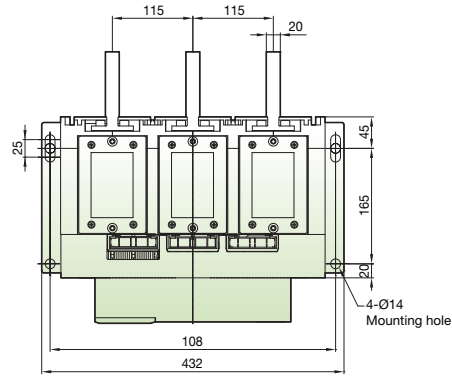

3P

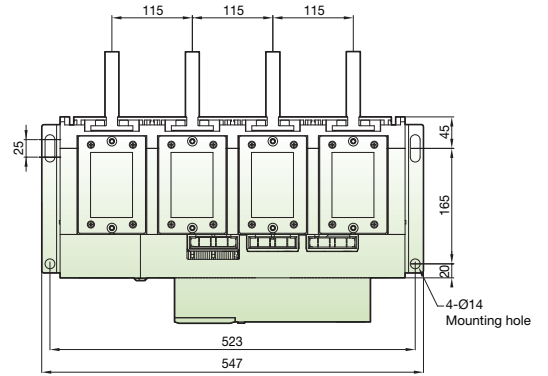

4P

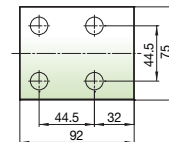
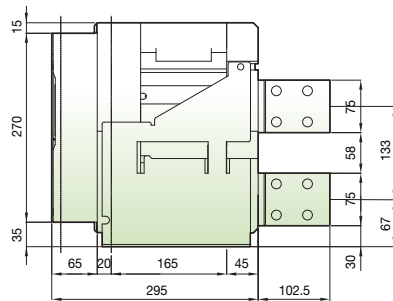

<Conductor>

Dimensions

Fixed type (DDH/DDV-40E)

(Unit : mm)

Vertical type

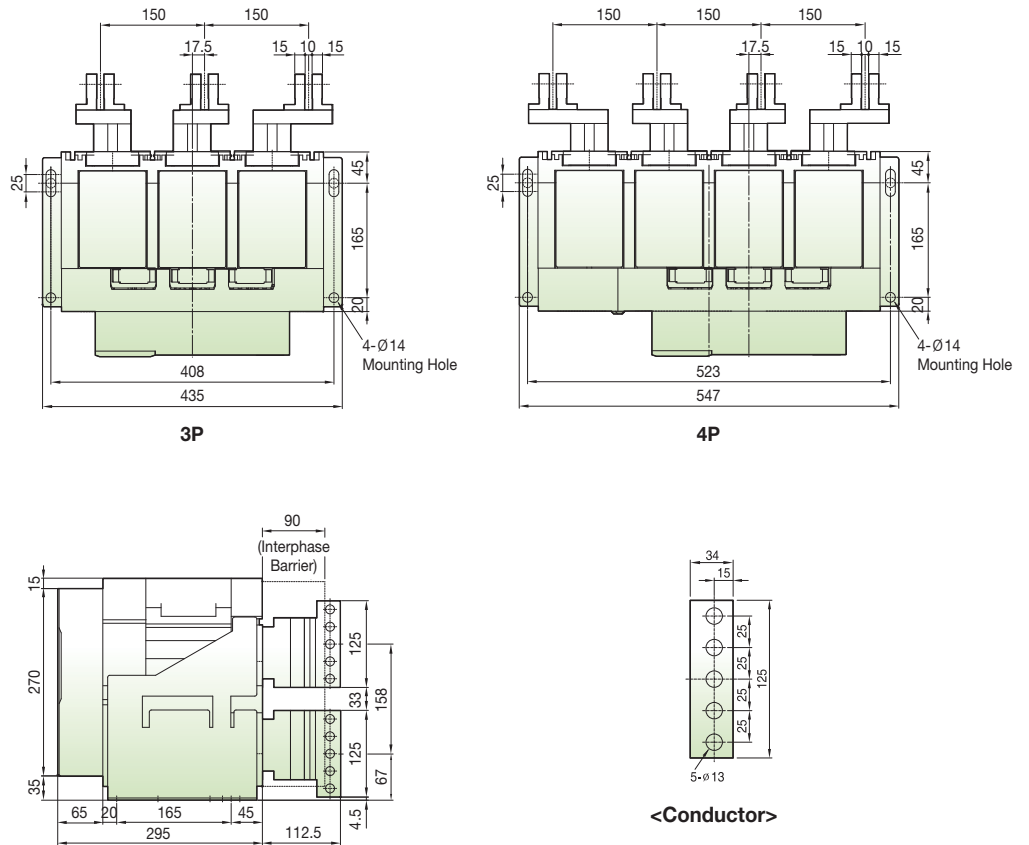

Door Frame

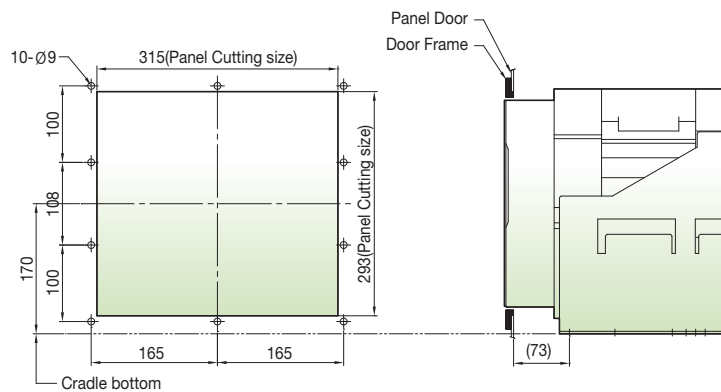

Draw-out type (DDH/DDV-08~20D)

(Unit : mm)

Front view

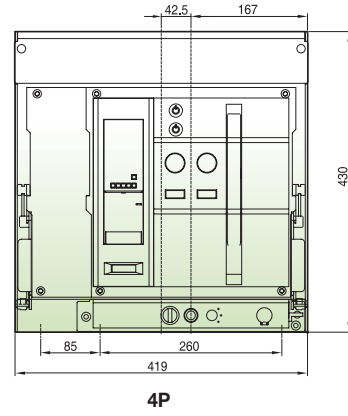
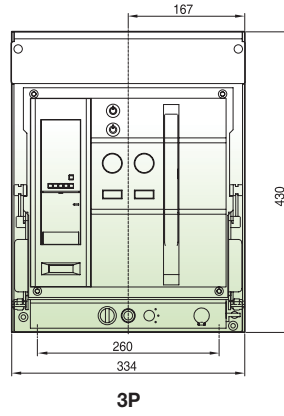

Vertical type

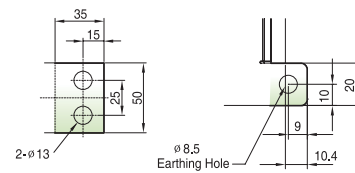
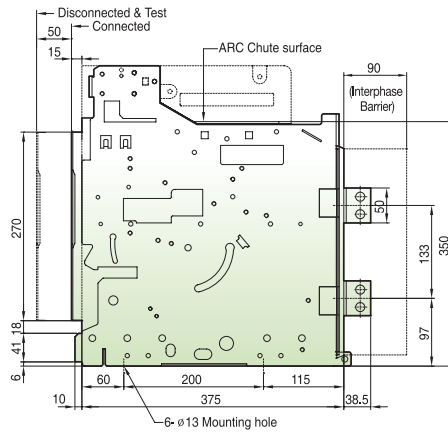
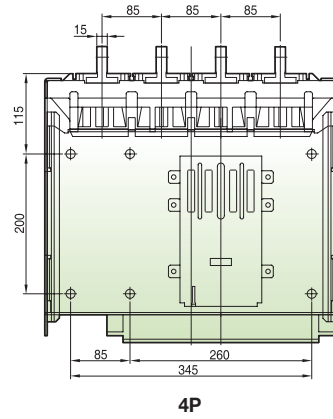
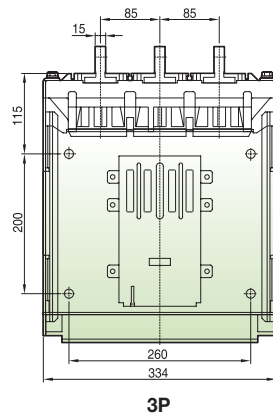

<Conductor>

Dimensions

Draw-out type (DDH/DDV-08~20D)

(Unit : mm)

Horizontal type

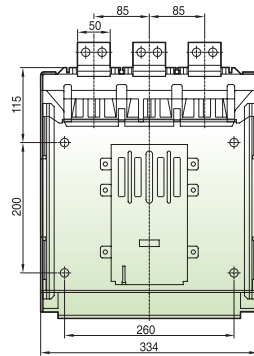

3P

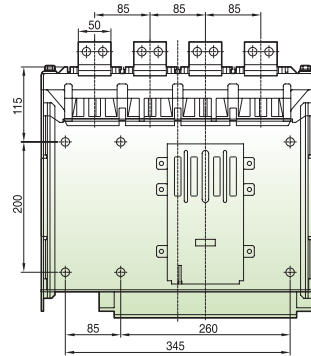

4P

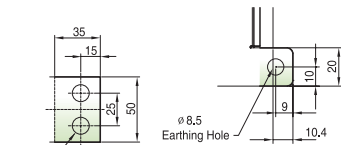
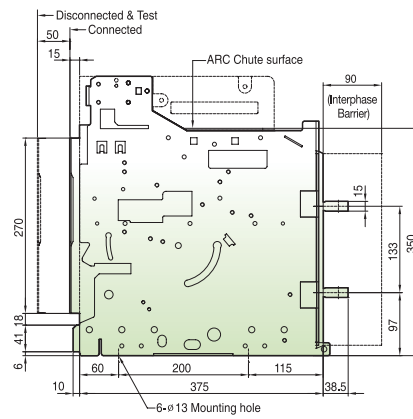

<Conductor>

Front connection type

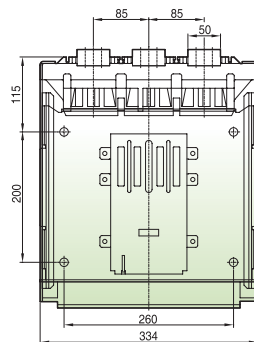

3P

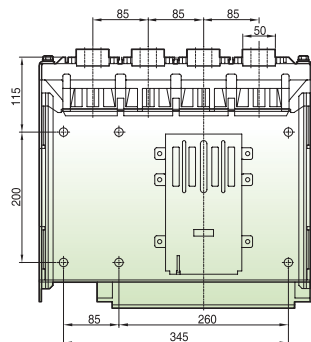

4P

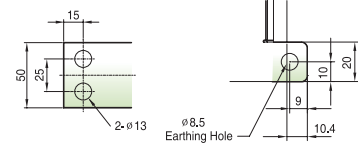
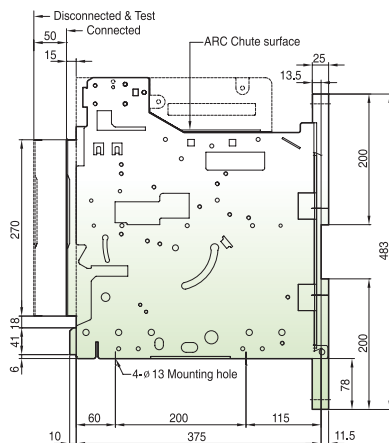

<Conductor>

Draw-out type (DDH/DDV-25D)

(Unit : mm)

Front view

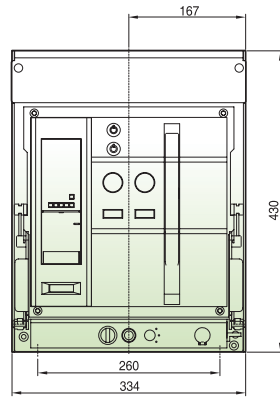

3P

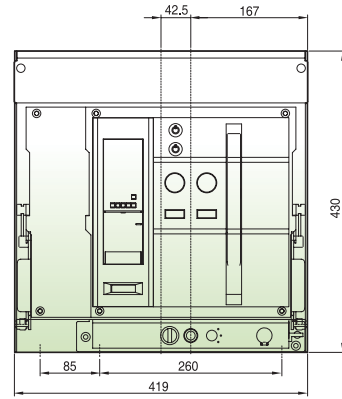

4P

Vertical type

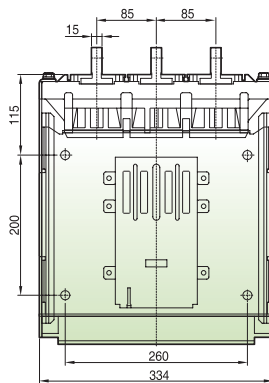

3P

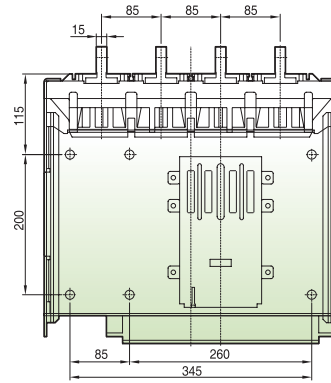

4P

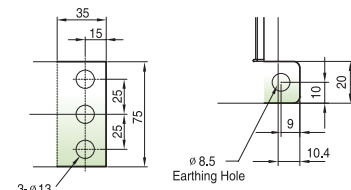
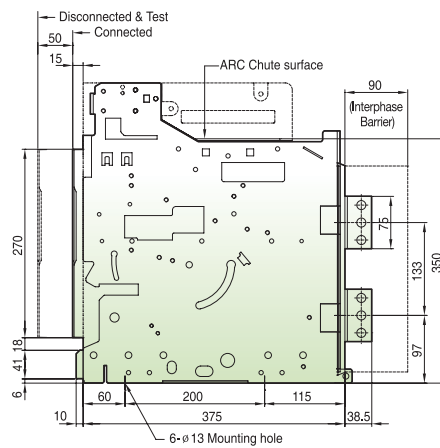

<Conductor>

Dimensions

Draw-out type (ADH/ADV-08~25E, DDH/DDV-08~32E)

(Unit : mm)

Front view

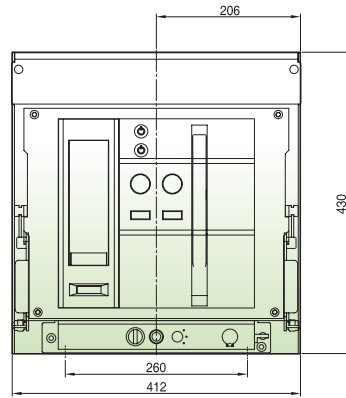

3P

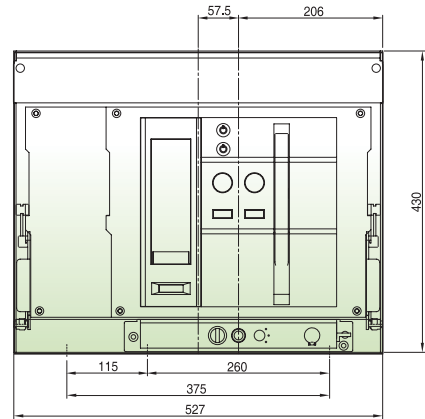

4P

Vertical type

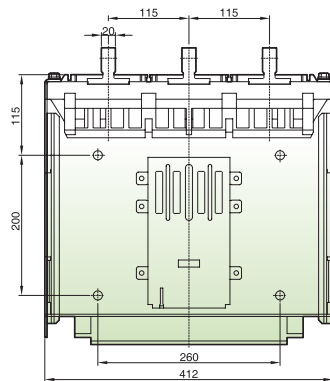

3P

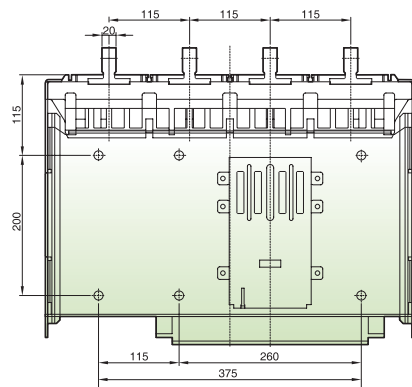

4P

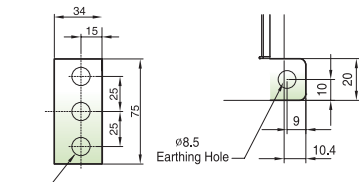
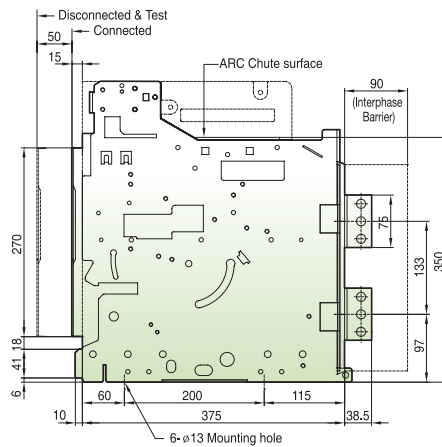

<Conductor>

Draw-out type (ADH/ADV-08~25E, DDH/DDV-08~32E)

(Unit : mm)

Horizontal
type

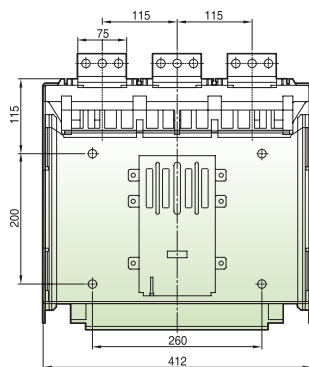

3P

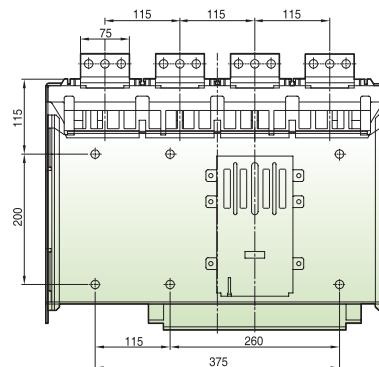

4P

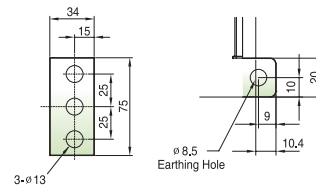
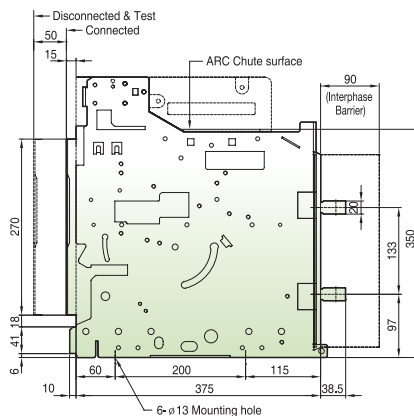

<Conductor>

Front
connection
type

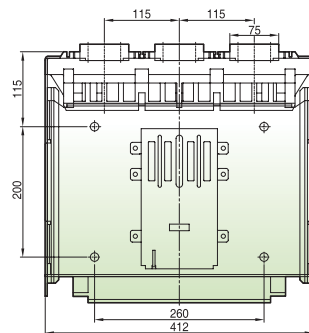

3P

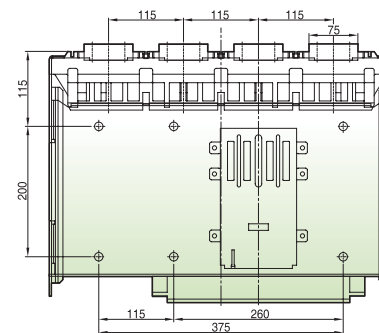

4P

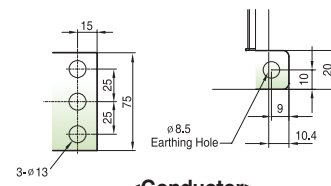
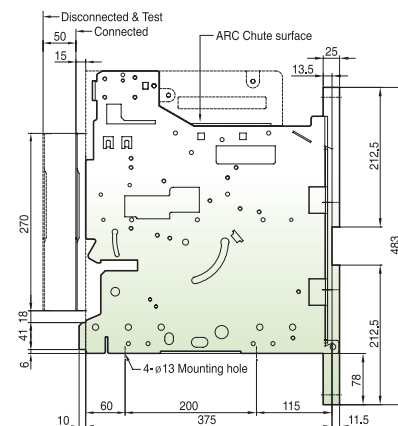

<Conductor>

Dimensions

Draw-out type (ADH/ADV-32E)

(Unit : mm)

Front view

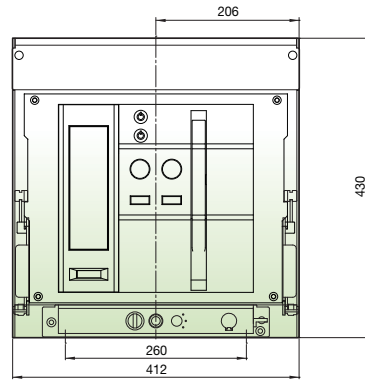

3P

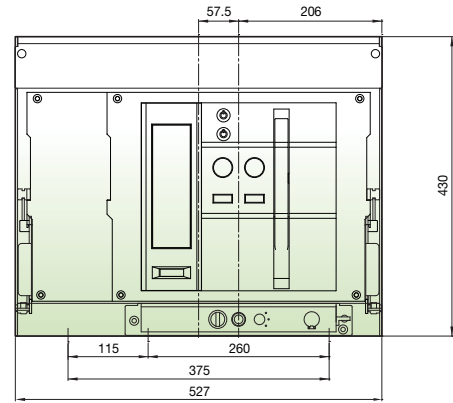

4P

Vertical type

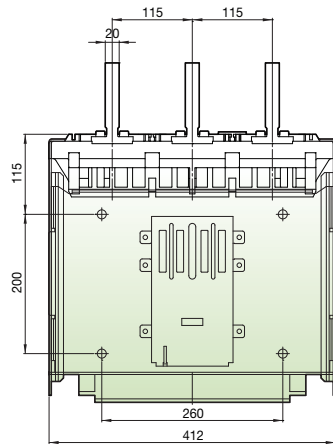

3P

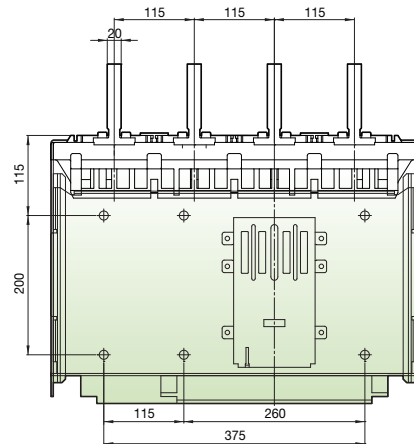

4P

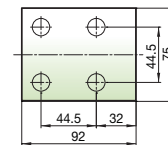
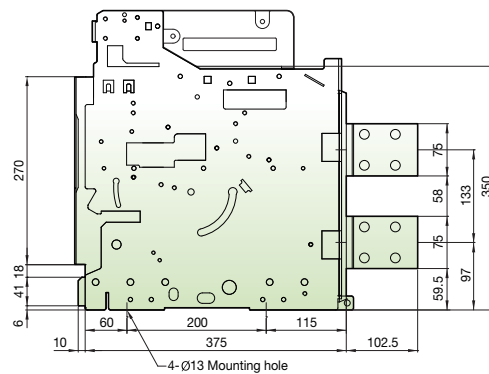

<Conductor>

Draw-out type (DDH/DDV-40E)

(Unit : mm)

Vertical type

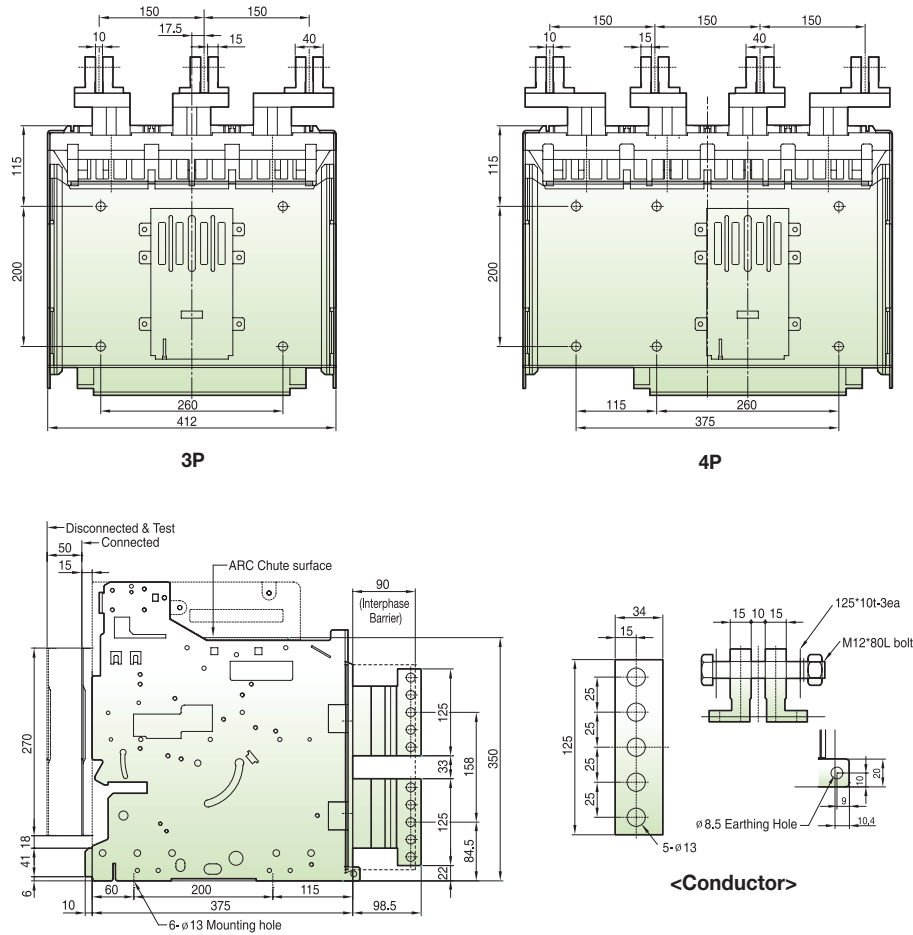

Door Frame

<Dimensions>

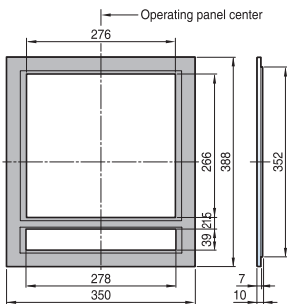

<Mounting hole>

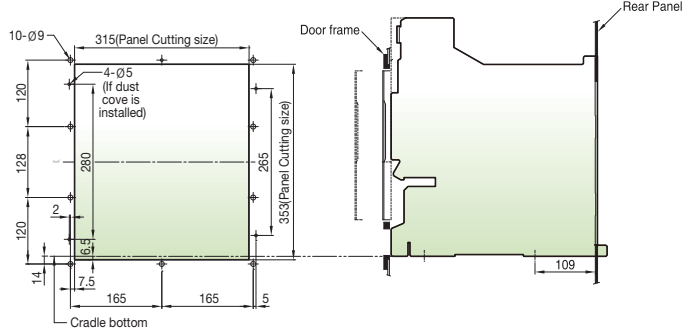

<Side hole>

<Panel cutting>

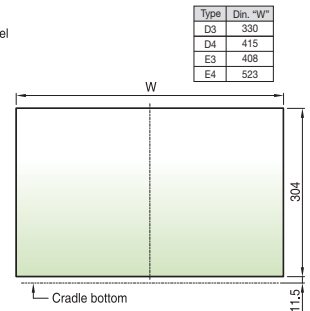

Note) The dimensions are for drawout type.

DC ACB Trip relays

S type: 'Supreme meter' type

Overload protection

- Long-time delay
- Thermal

Short-circuit protection

- Short-time delay / Instantaneous
- I²t On/Off optional (for short-time delay)

Ground fault protection

- Ground fault: Available to select I²t On/Off
- Alarm/Trip selectable

Start-up protection

- Short time, instantaneous, ground fault protection
- Start-up Setting current and holding time setting

Controlling relay group

- Dual setting possible: Group A and B selection

Load control

- Load control setting current input

Fault recording

- Records Max. up to 128 fault information about fault type, fault phase, fault value, occurrence time of fault
- Record the 4 most recent accident waveforms (Accident waveform storage for each 128ms before and after an accident)

Event recording

- Records events of device related to setting change, operation and state change. (Max. up to 128)

Self-diagnosis function

- Trip coil connection check
- Rating plug normal check
- Temperature monitoring
- Trip test

Communication

- Modbus / RS485

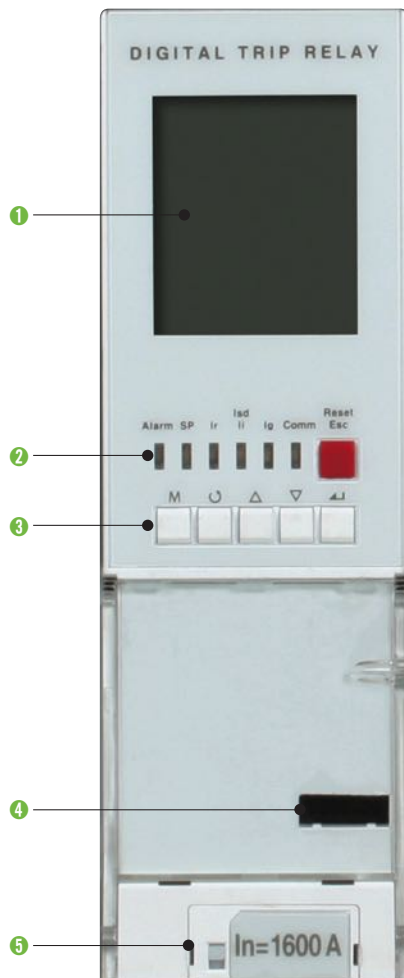

1 Graphic LCD: Indication of measurement and information

2 LED: Indication of trip info. and overload state

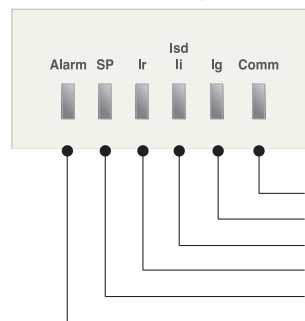

- Comm: LED indicating comm. state (Blink when running)
- Ig: LED indicating ground-fault
- Isd/II: LED indicating short-time or instantaneous tripping
- Ir: LED indicating long-time delay
- SP: Self-protection LED and battery test LED
- Alarm: LED indicating an overload (Turn on above 90%, Blink above 105%)

3 Key: Move to menu or reset

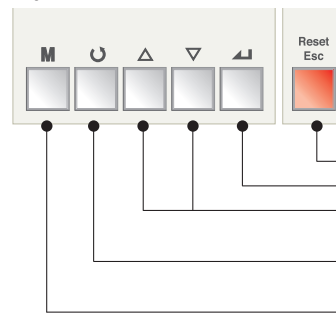

- Reset/ESC: Fault reset or ESC from menu
- Enter: Enter into secondary menu or setting input
- Up/Down: Move the cursor up/down on screen or increase/decrease a setting value
- Right/Left: Move the cursor or setting right/left on screen (Rotation)
- Menu: Menu display Measurement display

4 Test terminal: OCR test terminal (Connected with OCR tester)

5 Rating Plug: Rated current (In)

Protection

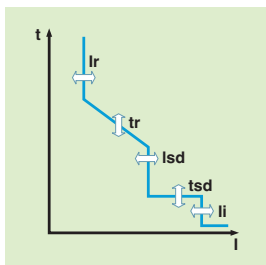

Long-time (OCR-L)						
Pick-up (A)	$I_r = I_n \times \dots$	40%~100% (5% Step) * Tripping between 1.05 and 1.2×I _r				
Time delay (s)	$t_r @ (1.5 \times I_r)$	11.2	22.5	45.1	90.2	180.5 270.8 361.1 451.4 541.7 Off
Accuracy: ±10% or less than ±100ms	$t_r @ (6.0 \times I_r)$	0.5	1	2	4	8 12 16 20 24 Off
	$t_r @ (7.2 \times I_r)$	0.34	0.69	1.38	2.7	5.5 8.3 11 13.8 16.5 Off
Short time (OCR-S/OCR-S2)						
Pick-up (A)	$I_{sd} = I_r \times \dots$	150%~1000%, Off (5% Step)				
Accuracy : ±10%						
Current setting (s)	t_{sd}	I^2t Off	0.05s~0.4s, 0.05s Step			
Accuracy: ±10% or ±50ms		I^2t On	(In case of I^2t On, @10×I _r)			
Start-up Setting	Pick-up	150%~1000%(×I _r), Off (5% Step)				Start-up function is available when t_{sd} is set to I^2t Off
	Time delay (s)	0.10~30.00s, 0.05s Step				
Instantaneous (OCR-I)						
Pick-up (A)	$I_{li} = I_n \times \dots$	150%~1000%, Off (5% Step)				
Time delay		50ms				
Start-up Setting	Pick-up	150%~1000%(×I _r), Off (5% Step)				
	Time delay (s)	0.10~30.00s, 0.05s Step				
Ground fault (OCR-Ig)						
Pick-up (A)	$I_{lg} = I_n \times \dots$	20%~100%, Off (5% Step)				
Time delay (s)	t_g	I^2t Off	0.10s~3.00s, 0.05s Step			
Accuracy : ±10% (I _g >0.4I _n) ±20% (I _g ≤0.4I _n)		I^2t On	(In case of I^2t On, @1 × I _n)			
Start-up Setting	Pick-up	150%~1000%(× I _n), Off (5% Step)				Start-up function is available when t_{sd} is set to I^2t Off
	Time delay (s)	0.10~30.00s, 0.05s Step				

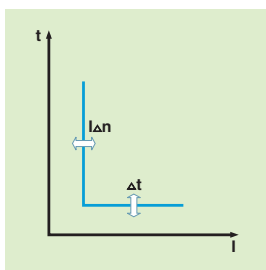

Note) 1. Switch on to fault time: 100ms

Other Protection	Pick-up			Time delay (s)		
	Setting range	Step	Accuracy	Setting range	Step	Accuracy
Under voltage (UVR)	50%~95%	5%	±5%	1.2s~40.00s	0.1s	±10%
Over voltage (OVR)	105%~120%					
Current unbalance (UNBAL)	5%~90%	5%	±5% (I _{max} -I _{min})×(±2%)	0.50s~60.00s	0.1s	±10%
Reverse power (RPR)	-10%~-30%	5%	10%	0.50s~60.00s	0.1s	±10%

* Under voltage setting

- Rated voltage
1000~160V: 50~95%, 159~146V : 55~95%, 145~134V : 60~95%, 133~124V : 65~95%, 123~115V : 70~95%, 114~107V : 75~95%, 106~110V: 80~95%

* Over voltage setting

- Rated voltage
100~917V: 105~120%, 918~957V : 105~115%, 958~1000V : 105~110%

* Current unbal

DC Compact Switch-Disconnecter

- Rated current 800 ~ 1600A
- Rated operational voltage:
 - DDH type (3P: 750Vdc, 4P: 1200Vdc)
 - DDV type (3P: 1000Vdc, 4P: 1500Vdc)
- Rated short-time current (Icw): 50kA/1s
- Operation durability without maintenance: 12,500 times
- Various control power sources
- Various accessories
- Application Standards and Certification: IEC 60947-3 (DEKRA CB certification), GB 14048.3 (CCC certification)



Fixed type



Drawable type

Type and ratings

Commonness														
Rated insulation voltage (Ui)	(V)	1500												
Rated impulse withstand voltage (Uimp)	(kV)	12												
Rated operational voltage (Ue)	(V)	750V DC (3P), 1200V DC (4P)				750V DC (2P)				1000V DC (3P), 1500V DC (4P)				
Number of poles	(P)	3, 4				2				3, 4				
Installation type		Fixed / Draw-out				Fixed				Fixed / Draw-out				
Related standards		IEC 60947-3 (DEKRA CB certification), GB 14048.3 (CCC certification)				IEC 60947-3				IEC 60947-3 (DEKRA CB certification), GB 14048.3 (CCC certification)				
Type	DDH				DDV				DDV					
	DDH-08C	DDH-10C	DDH-13C	DDH-16C	DDV-08C	DDV-10C	DDV-13C	DDV-16C	DDV-08C	DDV-10C	DDV-13C	DDV-16C		
Ampere frame (AF)	800AF	1000AF	1250AF	1600AF	800AF	1000AF	1250AF	1600AF	800AF	1000AF	1250AF	1600AF		
Utilization category (According to IEC 60947-3)	DC-22A				DC-22A				DC-23A					
Rated making capacity (Icm)	(kA peak)	50				50				50				
Rated short-time withstand current (Icw)	(kA/1s)	50				50				50				
Operation time (ms)	Opening time	Less than 25ms under Icw/Less than 75ms over Icw												
	Closing time	80ms under												
Connection	Horizontal type	○				○				○				
	Vertical type	● (Default)				● (Default)				● (Default)				
Mechanical and electrical life cycle														
Endurance (times) (Without maintenance)	Mechanical (120 times/hr)	12,500												
	Electrical (L/R 2ms) (30 times/hr)	2,000	1,000	500	500	2,000	1,000	500	500	4,000	2,000	1,000	1,000	
Dimension and weight														
Weight (3P/4P)	Draw-out	Without cradle	15.5(3P) / 19(4P)				-				15.5(3P) / 19(4P)			
		With cradle	22(3P) / 26(4P)				-				22(3P) / 26(4P)			
	Fixed	15.5(3P) / 19(4P)				14(2P)				15.5(3P) / 19(4P)				
External dimensions (W×H×D)	Draw-out	361.3×267×255.4(3P), 361.3×267×326(4P)				-				361.3×267×255.4(3P), 361.3×267×326(4P)				
	Fixed	283×219.5×272.4(3P), 283×219.5×342.4(4P)				283×219.5×272.4(2P)				283×219.5×272.4(3P), 283×219.5×342.4(4P)				

Product connection

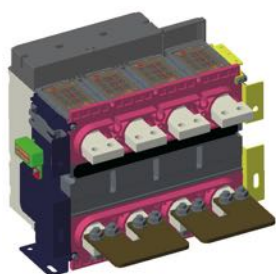

Upper Supply



Lower Supply

Operation voltage and connection diagram of DC ACB series

Poles	3P	3P	4P
DDH type	500 Vdc	750 Vdc	1200 Vdc
DDV type	500 Vdc	1000 Vdc	1500 Vdc
Connection diagram			

Note) If different circuit configurations are needed, please contact LS.

Type	Rated current	Busbar connection	Order code	Edifice	Order quantity	Weight (kg/set)
Fixed / Draw-out type	800-1600A	Vertical / Horizontal	70223472600	Short busbar : 1ea/unit, Heatsink : 1ea/unit M10 Bolt Set : 4ea/unit, M6 Bolt: 4ea/unit M4 Screw : 1ea/unit	3P : 1 unit	2kg/unit
					4P : 2 unit	
Fixed type	800~1000A	Front	70223472603	Short busbar : 1ea/unit M10 Nut Set : 4ea/unit	3P : 1 unit	0.6kg/unit
					4P : 2 unit	
	1250A		70223472601	Short busbar : 1ea/unit, Heatsink : 1ea/unit M10 Nut Set : 4ea/unit, M6 Bolt: 2ea/unit	3P : 1 unit	0.7kg/unit
	4P : 2 unit					
1600A	70223472602	Short busbar : 1ea/unit Heatsink : 1ea/unit, Barrier Pad : 1ea/unit M10 Nut Set : 4ea/unit, M6 Bolt: 4ea/unit	3P : 1 unit	5kg/unit		
	4P : 2 unit					

Control circuit diagram

This diagram is based on "CONNECTED" position of a circuit breaker and Opening, Motor charging, Releasing of locking plate should be normal condition.

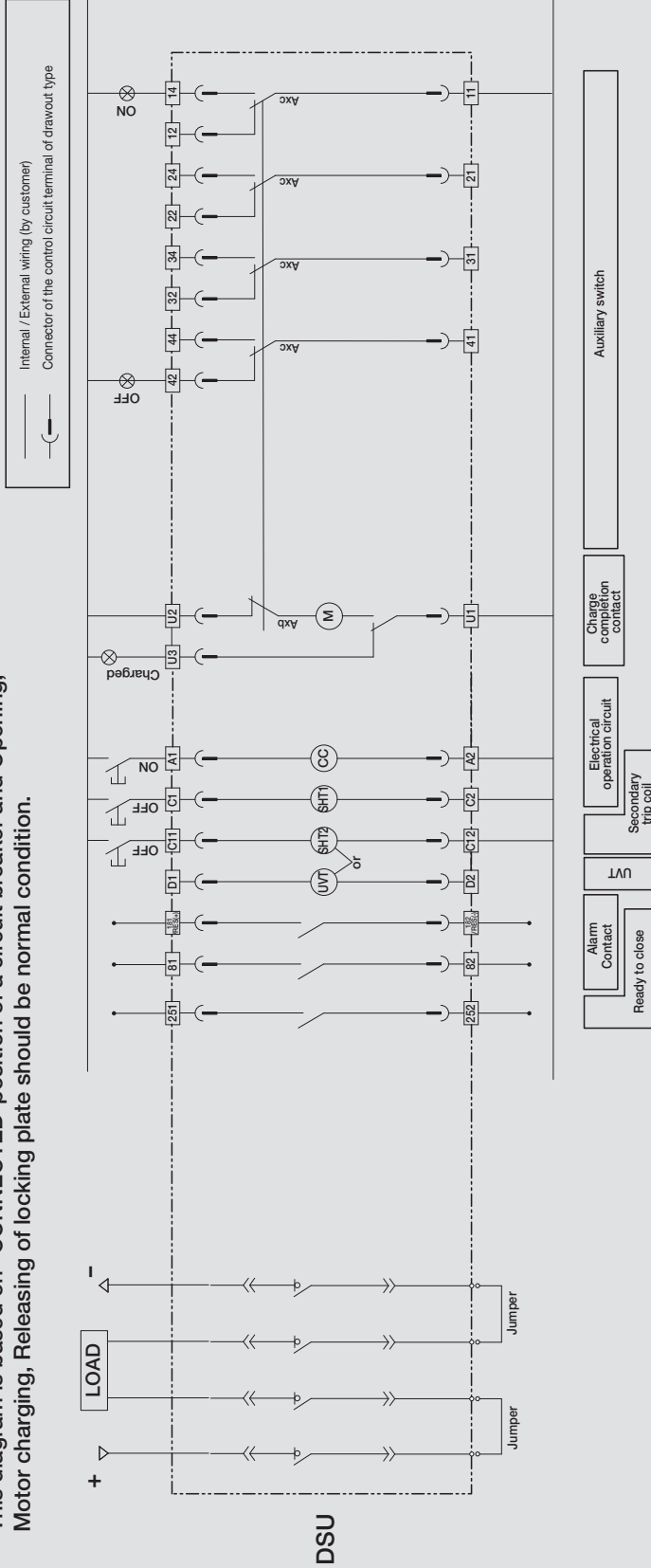

Terminal code description

11	12	~	41	42	Auxiliary switch "b" contact
11	14	~	41	44	Auxiliary switch "a" contact
U1	U3				Charge completion signal
U1	U2				Motor charging
A1	A2				Closing coil
C1	C2				Shunt trip
C11	C12				2nd shunt trip

Accessory code description

Axc	Auxiliary switch
CL1~CL4	Cell switch
(M)	Motor
(CC)	Closing coil
(SHT)	1st Shunt coil
(SHT2)	2nd Shunt coil
(UVT)	UVT coil

- Note) 1. The diagram is shown with circuit de-energized, all devices open and charged and relays in normal position
 2. Relay is normal condition and charging type is "Off-Charging"
 3. The standard of auxiliary contact is 4C.
 4. Option
 - Ready to close contact, UVT coil, Fully charged contact, secondary trip coil
 5. Contact configuration for Cell Switch can be changeable if necessary

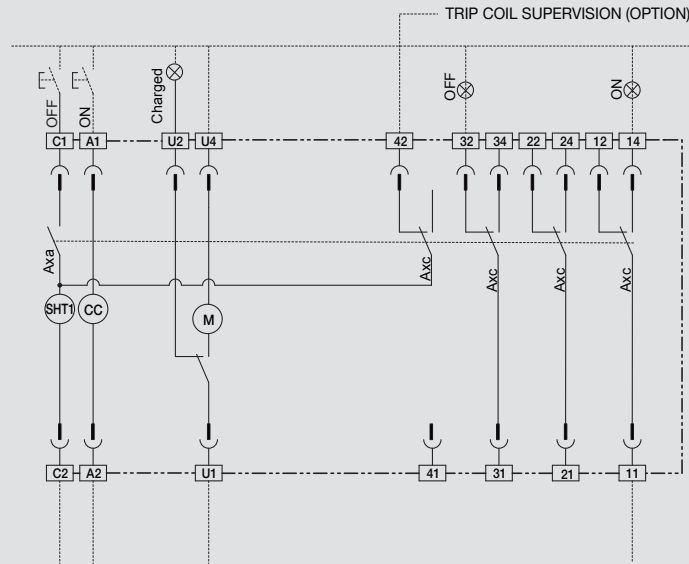

Electrical operation circuit Charge completion contact Auxiliary switch

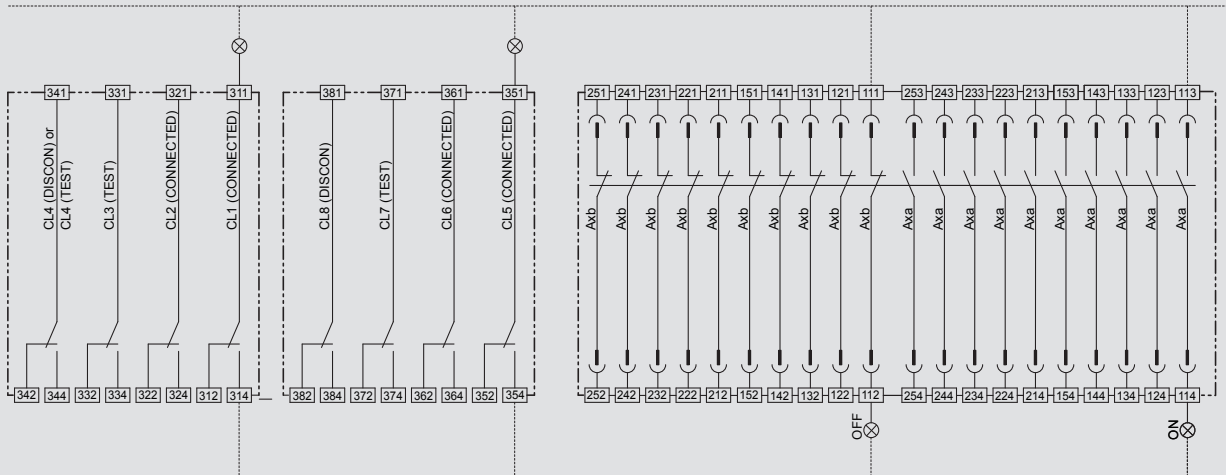

Cell switch 4C Cell switch 8C (4C Addition) MOC (Mechanical Operated Cell switches)

Terminal symbol

311 ~ 344	Cell switch
111 ~ 254	MOC

Dimensions

• 3P [Fixed H: Horizontal type / V: Vertical type]

(Unit : mm)

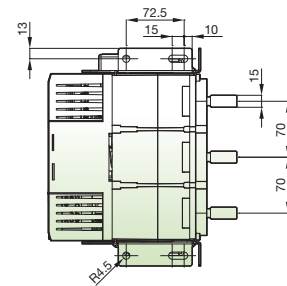
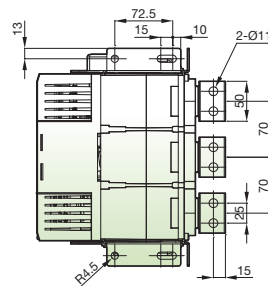
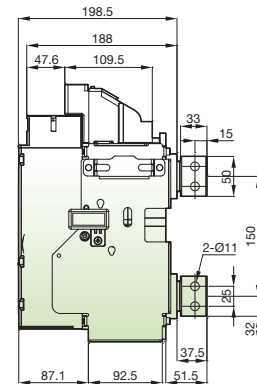
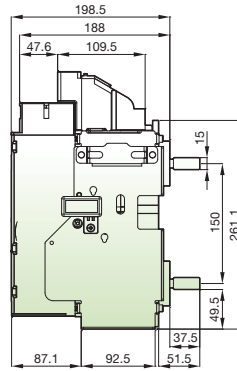
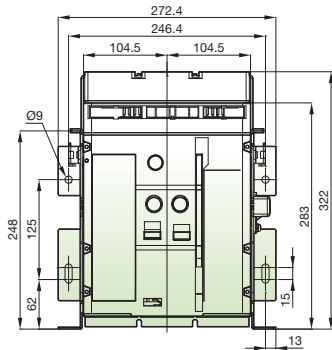

H Type (Horizontal type)

V Type (Vertical type)

• 3P [Fixed M: Upper-Horizontal type, Lower-Vertical type / N: Upper-Vertical type, Lower-Horizontal type]

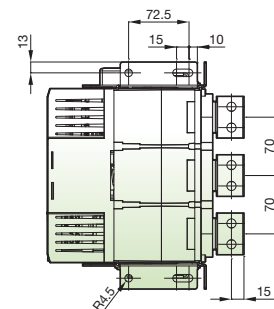
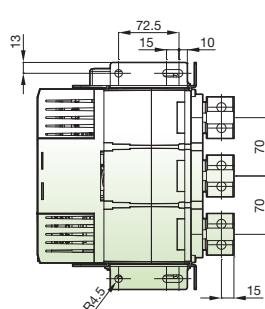
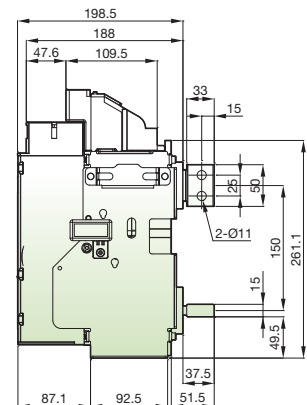
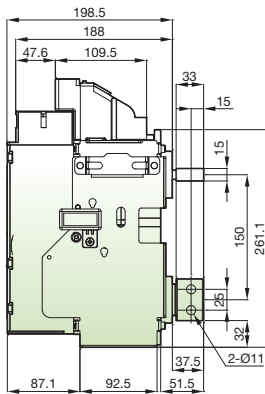
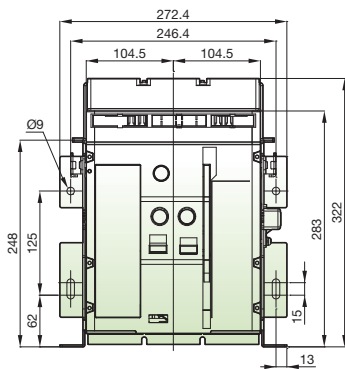

M Type

(Upper-Horizontal type, Lower-Vertical type)

N Type

(Upper-Vertical type, Lower-Horizontal type)

• 3P [Fixed P: Flat type / R: Spread type]

(Unit : mm)

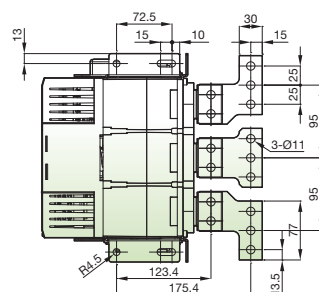
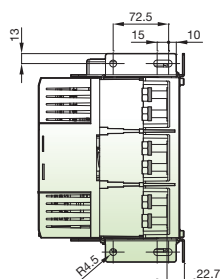
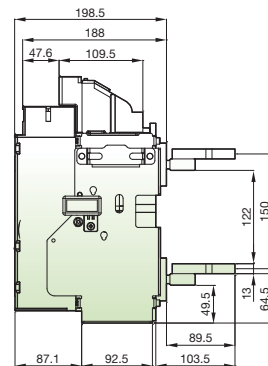
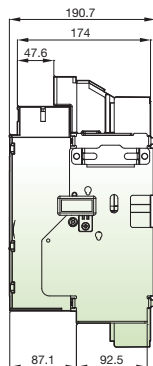
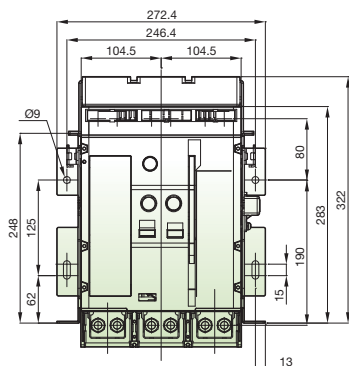

P Type (Plane type)

R Type (Spread type)

• 3P [Fixed Z: Flat spread type / T: Flat vertical type]

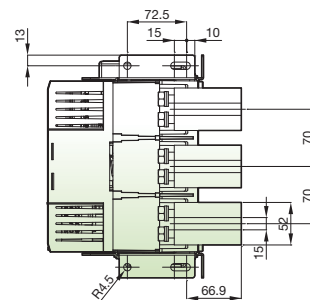
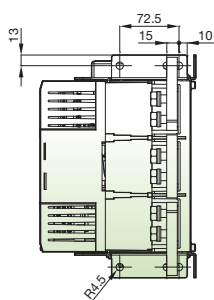
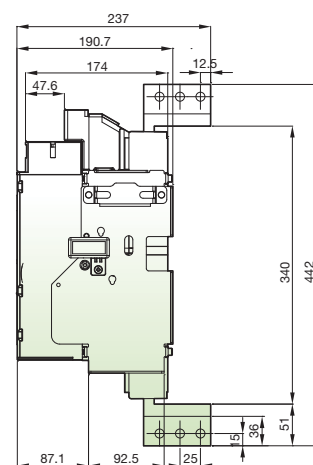
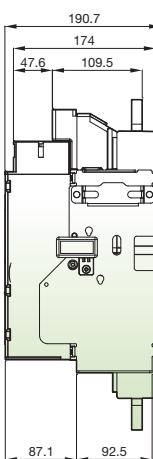
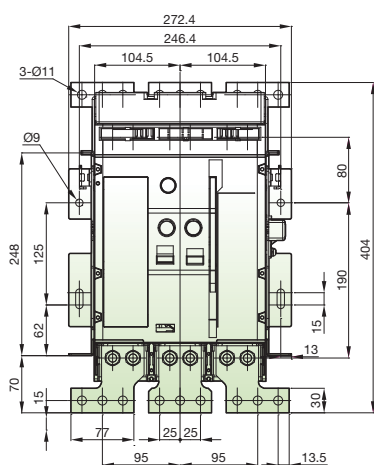

Z Type (Plane spread type)

T Type (Plane vertical type)

Dimensions

• 4P [Fixed H: Horizontal type / V: Vertical type]

(Unit : mm)

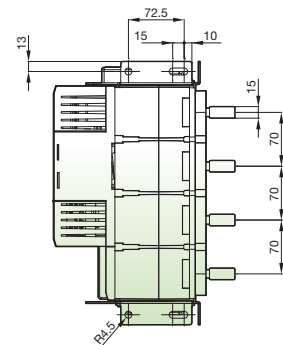
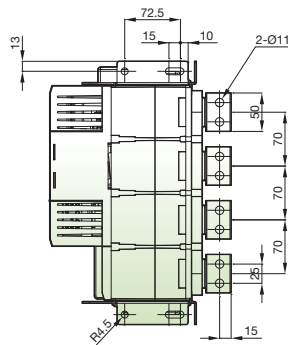
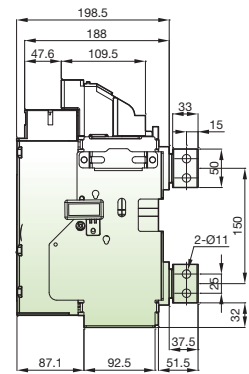
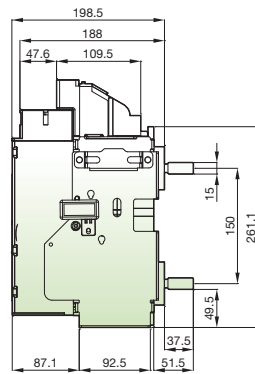
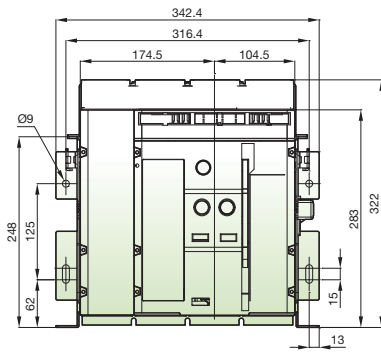

H Type (Horizontal type)

V Type (Vertical type)

• 4P [Fixed M: Upper-Horizontal type, Lower-Vertical type / N: Upper-Vertical type, Lower-Horizontal type]

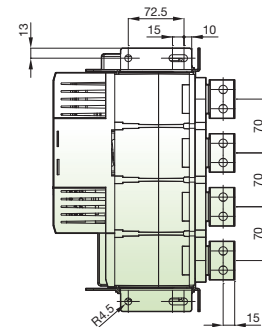
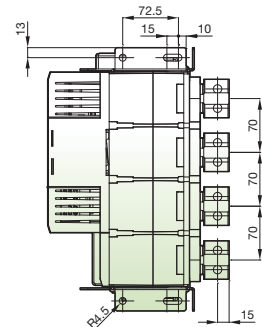
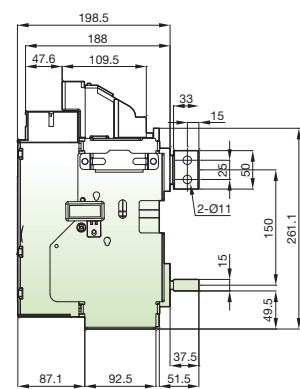
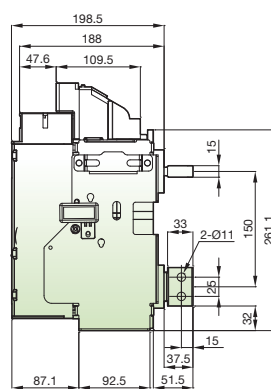
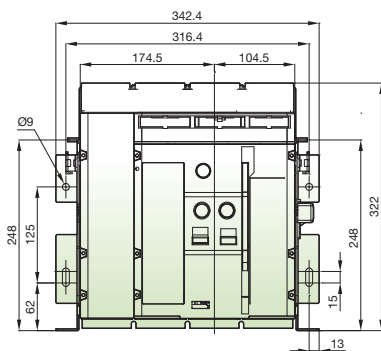

M Type
(Upper-Horizontal type, Lower-Vertical type)

N Type
(Upper-Vertical type, Lower-Horizontal type)

• 4P [Fixed P: Flat type / R: Spread type]

(Unit : mm)

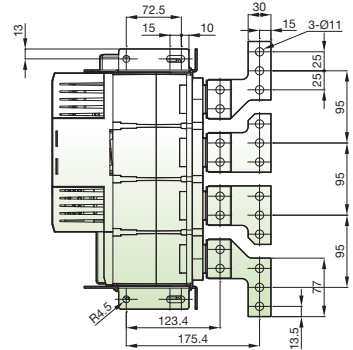
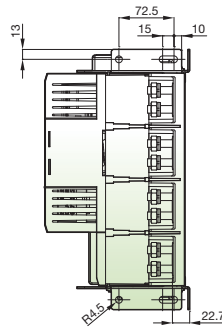
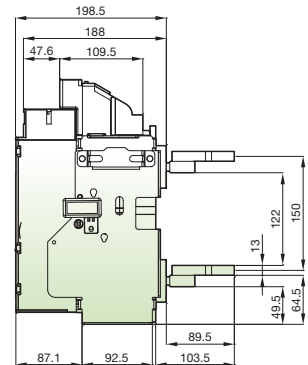
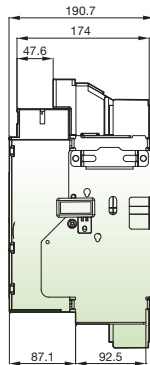
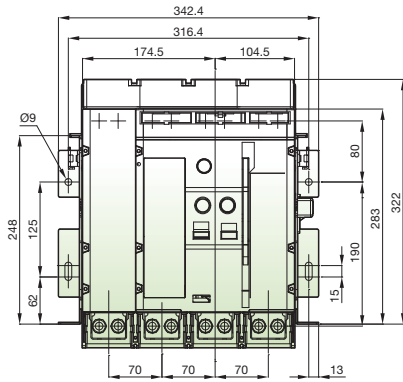

P Type (Plane type)

R Type (Spread type)

• 4P [Fixed Z: Flat spread type / T: Flat vertical type]

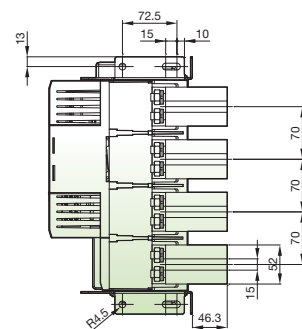
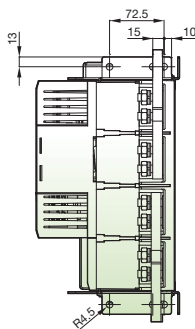
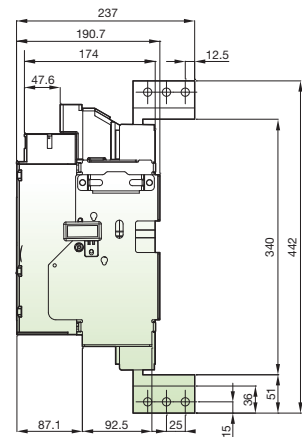
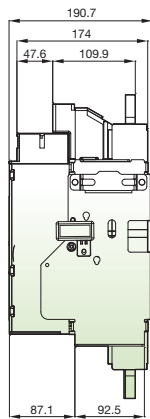
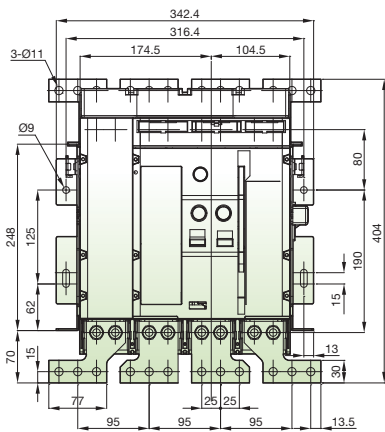

Z Type (Plane spread type)

T Type (Plane vertical type)

Dimensions

• 3P [Draw-out H: Horizontal type / V: Vertical type]

(Unit : mm)

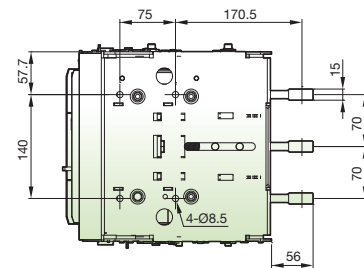
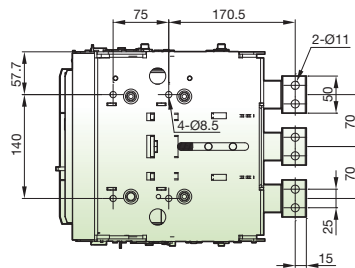
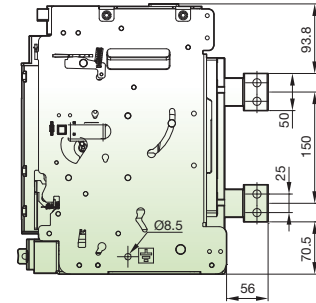
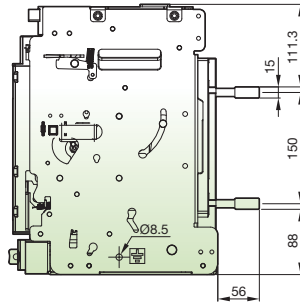
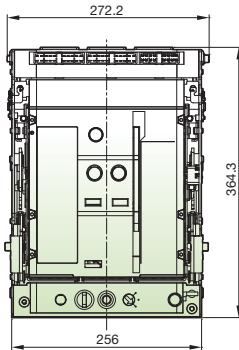

H Type (Horizontal type)

V Type (Vertical type)

• 3P [Draw-out M: Upper-Horizontal type, Lower-Vertical type / N: Upper-Vertical type, Lower-Horizontal type]

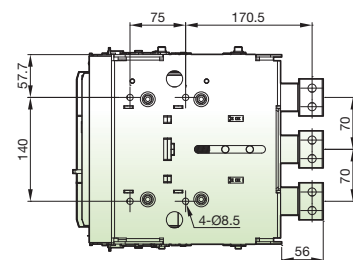
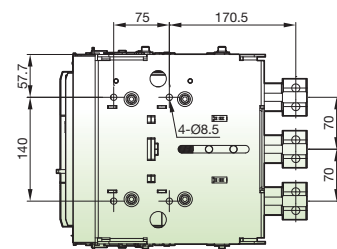
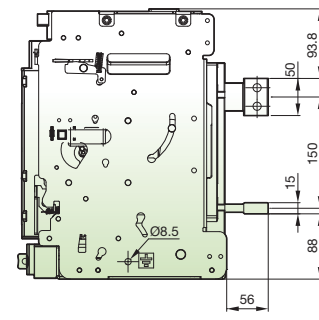
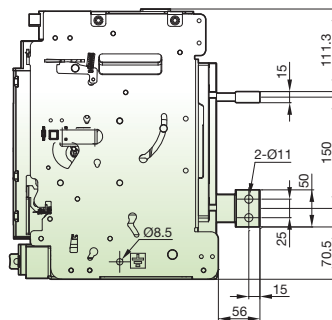
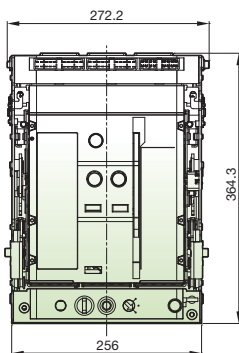

M Type
(Upper-Horizontal type, Lower-Vertical type)

N Type
(Upper-Vertical type, Lower-Horizontal type)

• 3P [Draw-out P: Flat type / R: Spread type]

(Unit : mm)

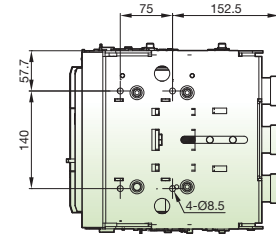
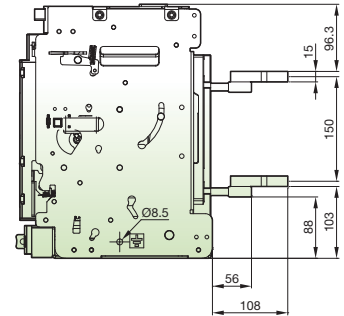
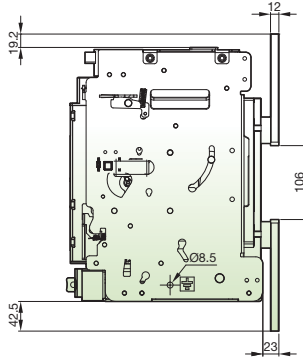
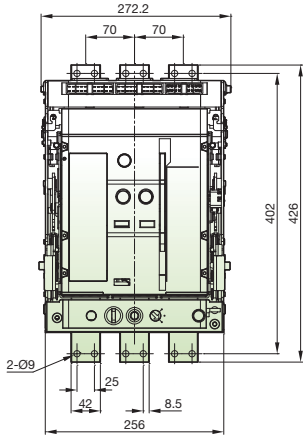

P Type (Plane type)

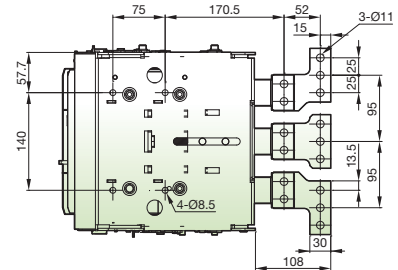

R Type (Spread type)

• 3P [Draw-out Z: Flat spread type / T: Flat vertical type]

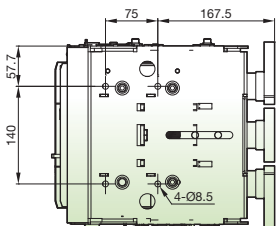
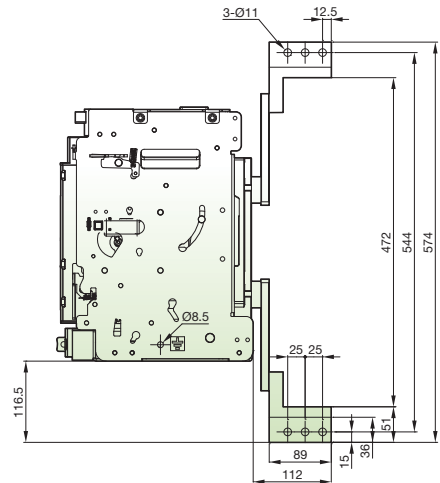
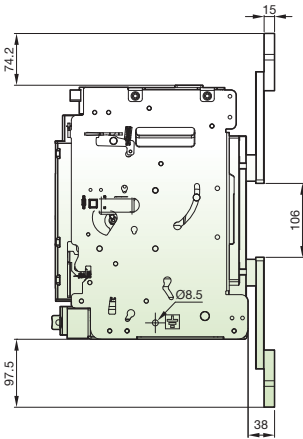
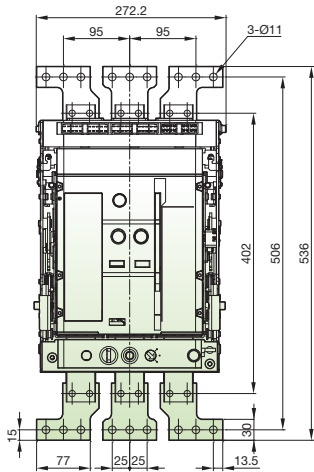

Z Type (Plane spread type)

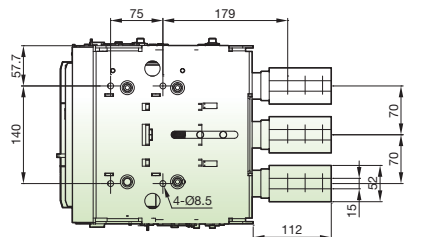

T Type (Plane vertical type)

Dimensions

• 4P [Draw-out H: Horizontal type / V: Vertical type]

(Unit : mm)

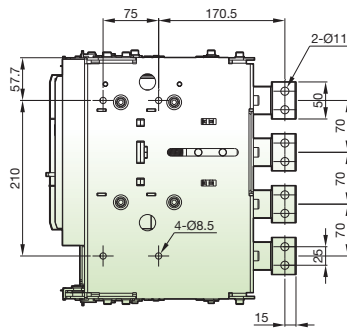
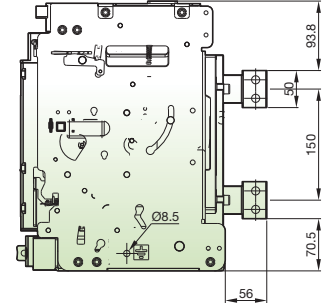
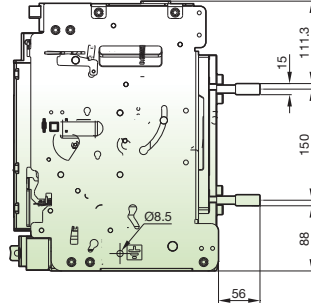
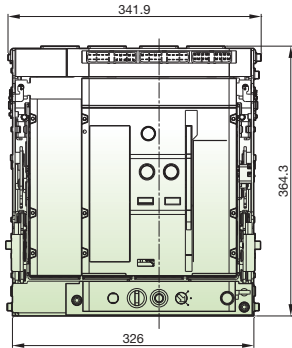

H Type (Horizontal type)

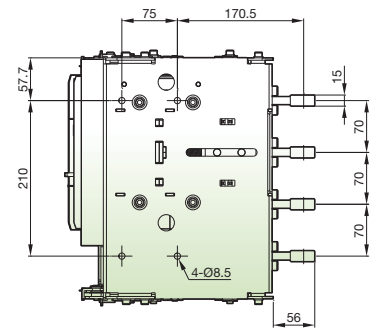

V Type (Vertical type)

• 4P [Draw-out M: Upper-Horizontal type, Lower-Vertical type / N: Upper-Vertical type, Lower-Horizontal type]

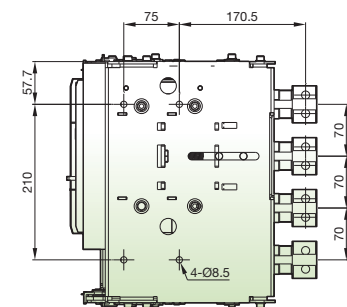
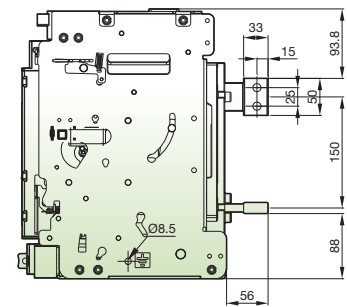
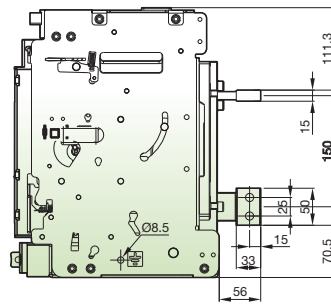
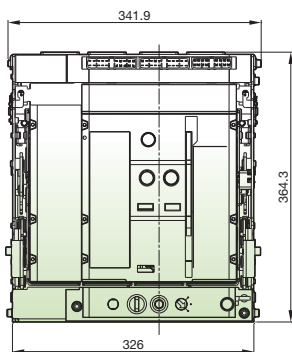

M Type
(Upper-Horizontal type, Lower-Vertical type)

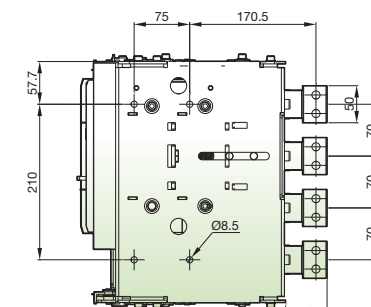

N Type
(Upper-Vertical type, Lower-Horizontal type)

• 4P [Draw-out P: Flat type / R: Spread type]

(Unit : mm)

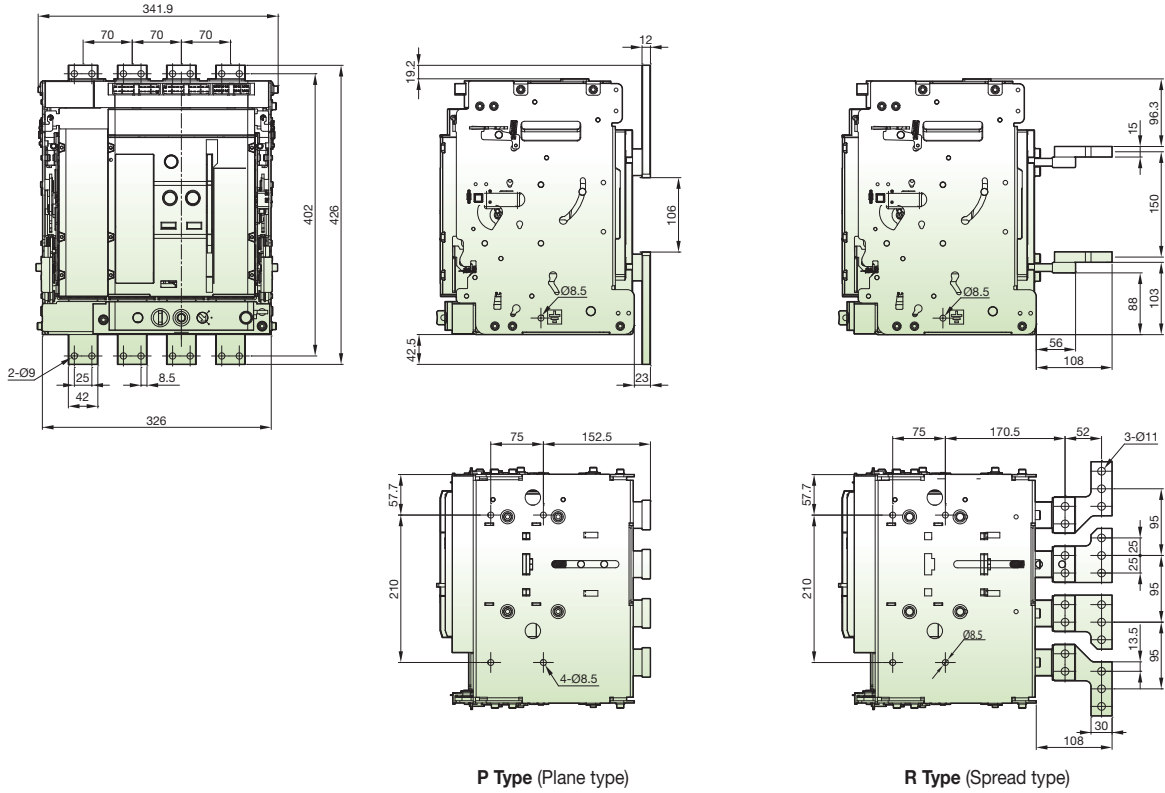

• 4P [Draw-out Z: Flat spread type / T: Flat vertical type]

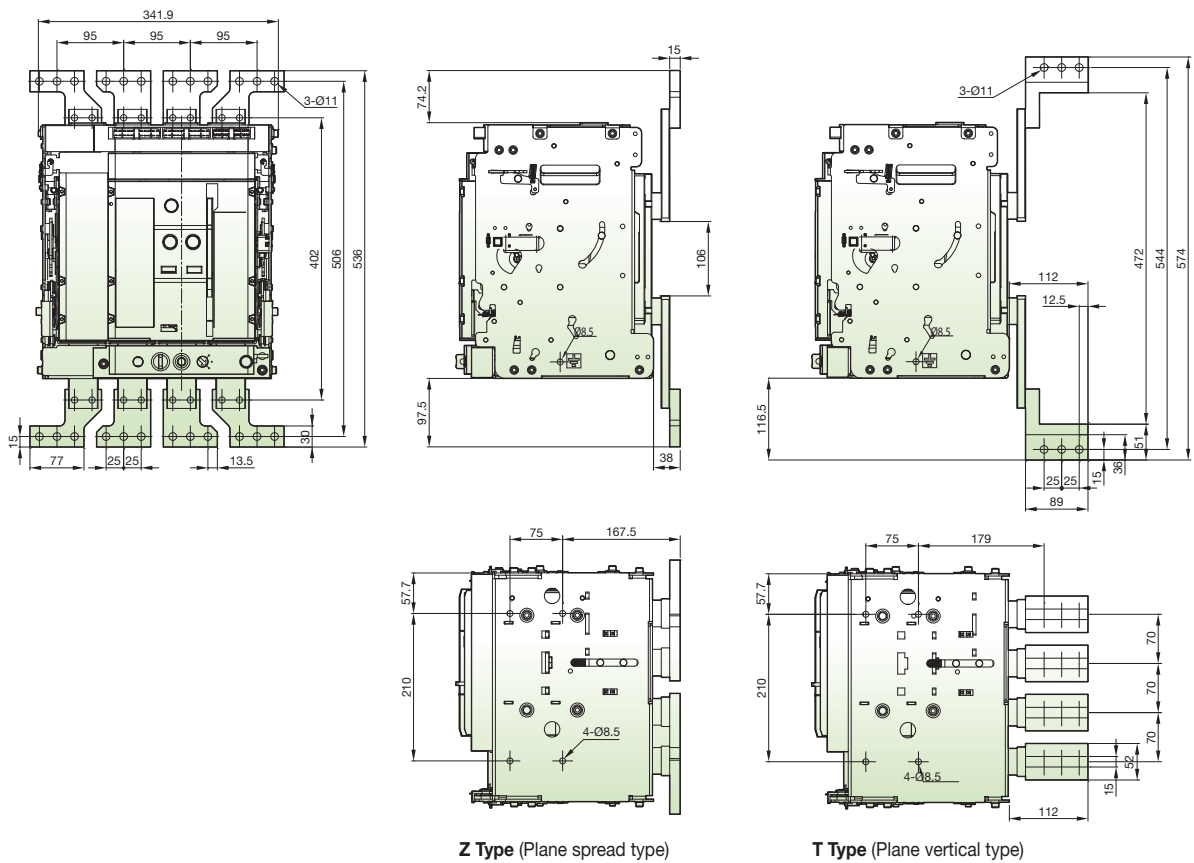

Dimensions

• 4P Plane type(P) *Fixed type(Up to 1000A)

(Unit : mm)

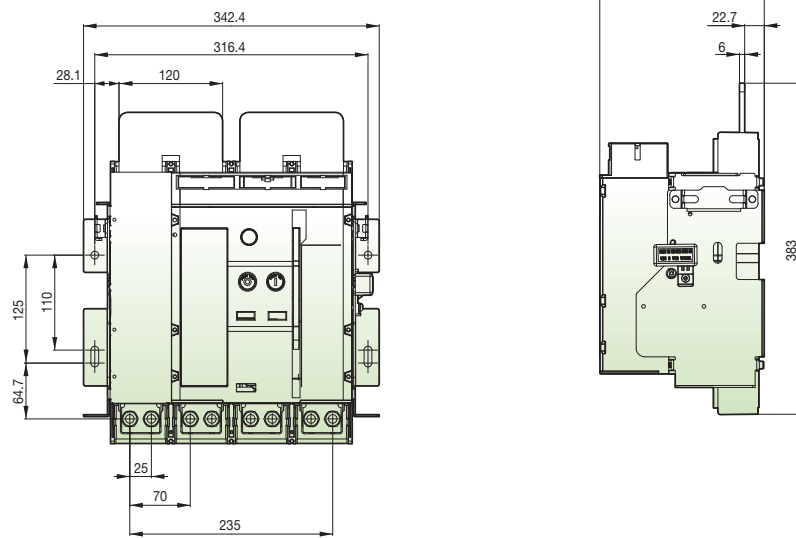

• 4P Plane type(P) *Fixed type(Up to 1250A)

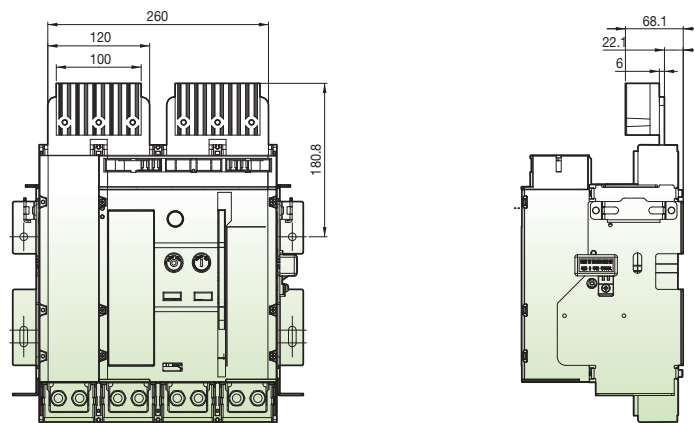

• 4P Plane type(P) *Fixed type(Up to 1600A)

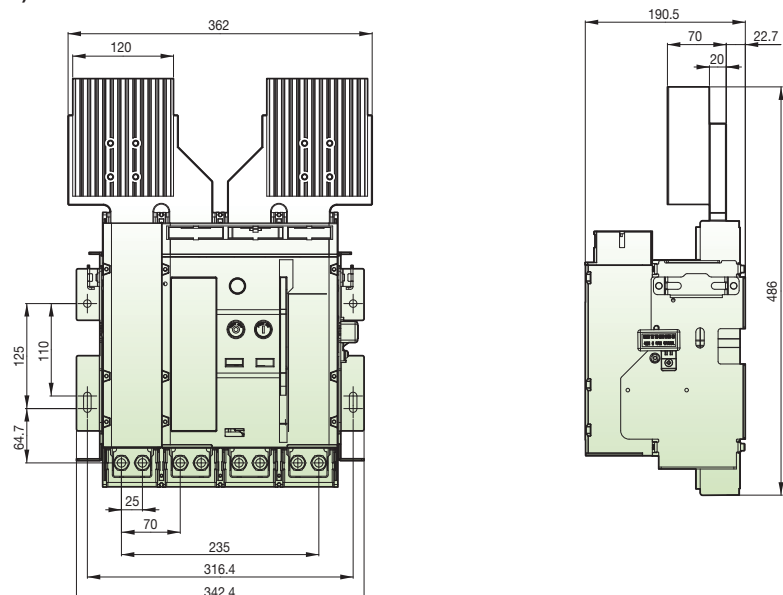

• 2P Fixed Type(Up to 1600A)

(Unit : mm)

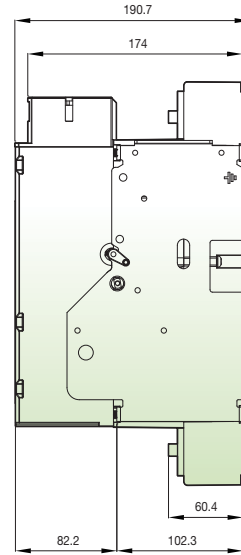
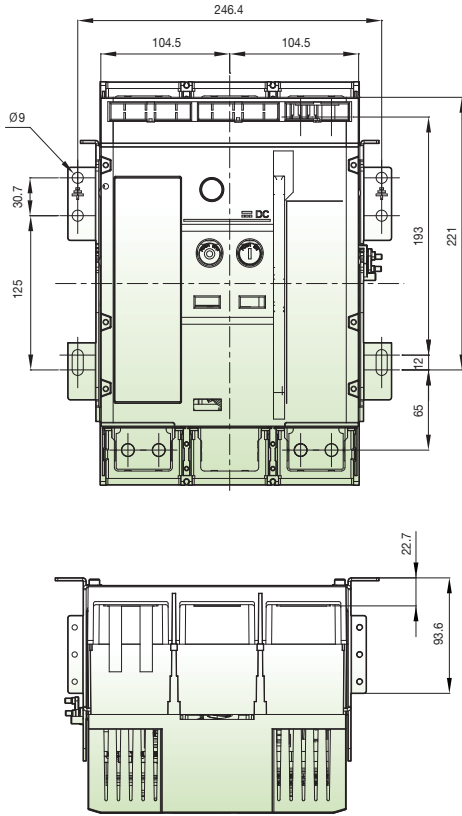

High Voltage DC Relay

What is LS High Voltage DC Relay?

The LS High Voltage DC Relay serves to supply and disconnect DC power, and contains hydrogen and nitrogen gas, which is optimized to withstand making and breaking. Therefore, it has excellent electrical durability, compact size, and low noise.



GPR Specifications



Rating

Model		GPR010	GPR040
Number of poles		1 Pole	1 Pole
Operating voltage, Ue		DC 450V	DC 450V
Rated impulse withstand voltage, Uimp		4kV	4kV
Conventional thermal current, Ith		10A	40A
Short time withstand current	120s	-	100A
	15Min	15A	60A
Durability	Mechanical (*) (3,600 operations per hour)	200,000 cycles	200,000 cycles
	Electrical	10A, 450VDC, 150,000cycles (at 360cycles/Hr)(only Making)	40A, 450VDC, 1,000cycles (at 1,200cycles/Hr)
Voltage drop (Initial)		0.5V @ 10A	0.2V @ 20A
Operating time		Max. 50ms	Max. 50ms
Release time		Max. 30ms	Max. 30ms
Insulation strength (Initial)		Min. 100MΩ(@500VDC)	Min. 100MΩ(@500VDC)
Size, W × H × D (mm)		56 × 28 × 45	67 × 35 × 47
Temperature range		-40 ~ 85℃	-40 ~ 85℃
Humidity		5-95% R.H.	5-95% R.H.
Weight		80g	145g
Certification		CE CCC	CE CCC

* The number of Mechanical times is the number that meets the basic performance after durability.

Features

Compact Design

Achieved compact size by filling with hydrogen and nitrogen gas to improve the breaking performance.

Proven Safety

High value of short circuit current withstanding.

Superior Reliability

Excellent performance with electrical and mechanical dururances.



	GPR100	GPR150	GPR250	GPR400
	1 Pole	1 Pole	1 Pole	1 Pole
	DC 450V	DC 450V	DC 450V	DC 450V
	4kV	4kV	4kV	4kV
	100A	150A	250A	400A
	225A	320A	500A	900A
	150A	225A	350A	600A
	200,000 cycles	200,000 cycles	200,000 cycles	200,000 cycles
	100A, 450VDC, 1,000cycles (at 1,200cycles/Hr)	150A, 450VDC, 1,000cycles (at 1,200cycles/Hr)	250A, 450VDC, 1,000cycles (at 360cycles/Hr)	400A, 450VDC, 1,000cycles (at 360cycles/Hr)
	0.04V @ 20A	0.04V @ 20A	0.02V @ 20A	0.02V @ 20A
	Max. 50ms	Max. 50ms	Max. 30ms	Max. 30ms
	Max. 30ms	Max. 30ms	Max. 10ms	Max. 10ms
	Min. 100M Ω (@500VDC)	Min. 100M Ω (@500VDC)	Min. 100M Ω (@500VDC)	Min. 100M Ω (@500VDC)
	81 × 39 × 70	81 × 39 × 70	92 × 45 × 87	100 × 58 × 91
	-40 ~ 85°C	-40 ~ 85°C	-40 ~ 85°C	-40 ~ 85°C
	5-95% R.H.	5-95% R.H.	5-95% R.H.	5-95% R.H.
	330g	330g	500g	630g
	CE (CCC)	CE cRU US (CCC)	CE (CCC)	CE (CCC)

High Voltage DC Relay

GPR-M/GPR-H Specifications



Rating

Model		GPR-M010	GPR-M040	GPR-M100
Number of poles		1 Pole	1 Pole	1 Pole
Operating voltage, Ue		DC 600V	DC 1000V	DC 1000V
Rated impulse withstand voltage, Uimp		4kV	4kV	6kV
Conventional thermal current, Ith		10A	40A	100A
Short time withstand current	120s	-	100A	225A
	15Min	15A	60A	150A
Durability	Mechanical (*) (3,600 operations per hour)	200,000 cycles	200,000 cycles	200,000 cycles
	Electrical	5A, 600VDC, 1,000cycles (at 360cycles/Hr)(only Making)	25A, 1000VDC, 1,000cycles (at 360cycles/Hr)	50A, 1000VDC, 1,000cycles (at 360cycles/Hr)
Voltage drop (Initial)		0.5V @ 10A	0.2V @ 20A	0.04V @ 20A
Operating time		Max. 50ms	Max. 50ms	Max. 50ms
Release time		Max. 30ms	Max. 30ms	Max. 30ms
Insulation strength (Initial)		Min. 100MΩ(@1000VDC)	Min. 100MΩ(@1000VDC)	Min. 100MΩ(@1000VDC)
Size, W × H × D(mm)		56×28×45	67×35×47	81×39×70
Temperature range		-40 ~ 85℃	-40 ~ 85℃	-40 ~ 85℃
Humidity		5-95% R.H.	5-95% R.H.	5-95% R.H.
Weight		80g	145g	330g
Certification		CE cRUUS CCC	CE cRUUS CCC	CE cRUUS CCC

* The number of Mechanical times is the number that meets the basic performance after durability.



	GPR-M150	GPR-M250	GPR-M400	GPR-M400-A	GPR-H500-A
	1 Pole	1 Pole	1 Pole	1 Pole	1 Pole
	DC 1000V	DC 1000V	DC 1000V	DC 1000V	DC 1500V
	6kV	6kV	6kV	6kV	8kV
	150A	250A	400A	400A	500A
	320A	500A	750A	750A	900A
	225A	350A	500A	500A	750A
	200,000 cycles	200,000 cycles	200,000 cycles	200,000 cycles	200,000 cycles
	75A, 1000VDC, 1,000cycles (at 360cycles/Hr)	125A, 1000VDC, 1,000cycles (at 360cycles/Hr)	200A, 1000VDC, 1,000cycles (at 360cycles/Hr)	200A, 1000VDC, 3,000cycles (at 360cycles/Hr)	200A, 1500VDC, 1,000cycles (at 360cycles/Hr)
	0.04V @ 20A	0.02V @ 20A	0.02V @ 20A	0.02V @ 20A	0.04V @ 20A
	Max. 50ms	Max. 30ms	Max. 30ms	Max. 30ms	Max. 35ms
	Max. 30ms	Max. 10ms	Max. 10ms	Max. 10ms	Max. 15ms
	Min. 100MΩ(@1000VDC)	Min. 100MΩ(@1000VDC)	Min. 100MΩ(@1000VDC)	Min. 100MΩ(@1000VDC)	Min. 100MΩ(@1000VDC)
	81×39×70	92×45×87	100×58×91	100×58×99	118×70×108
	-40 ~ 85°C	-40 ~ 85°C	-40 ~ 85°C	-40 ~ 85°C	-40 ~ 85°C
	5-95% R.H.	5-95% R.H.	5-95% R.H.	5-95% R.H.	5-95% R.H.
	330g	500g	630g	750g	1.3kg
	CE cRU ^{us} CCC	CE cRU ^{us} CCC	CE cRU ^{us} CCC	CE cRU ^{us}	CE cRU ^{us} CCC

High Voltage DC Relay

Dimensions

GPR010 / GPR-M010

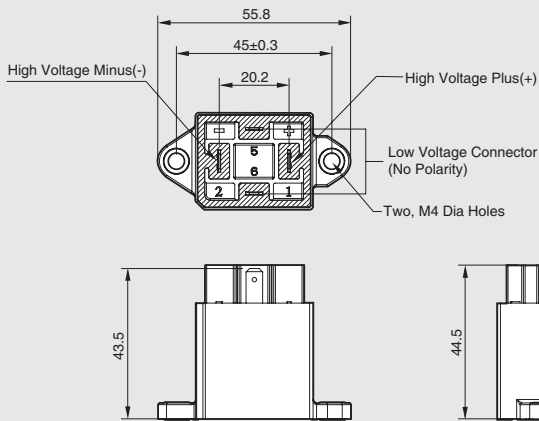

GPR040 / GPR-M040

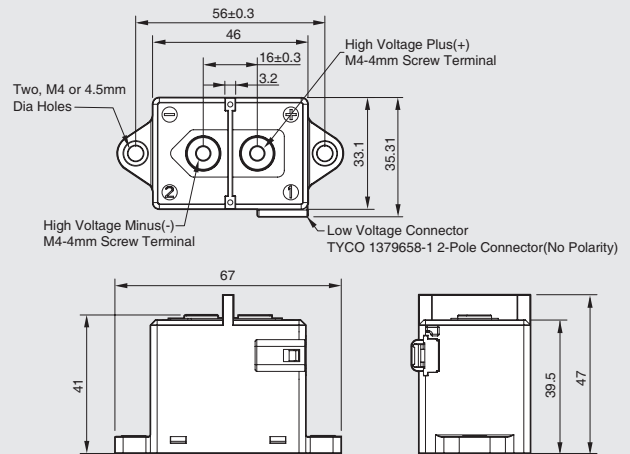

GPR100 / GPR-M100

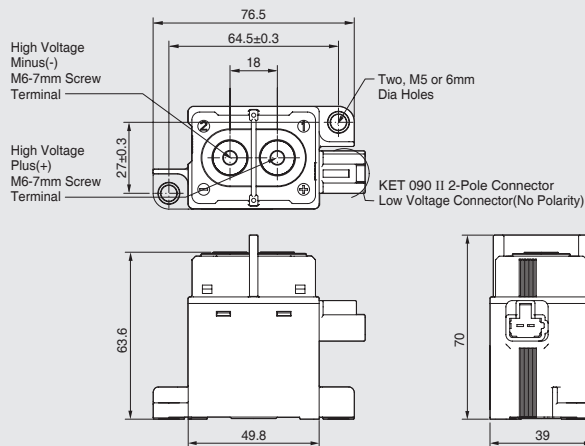

GPR150 / GPR-M150

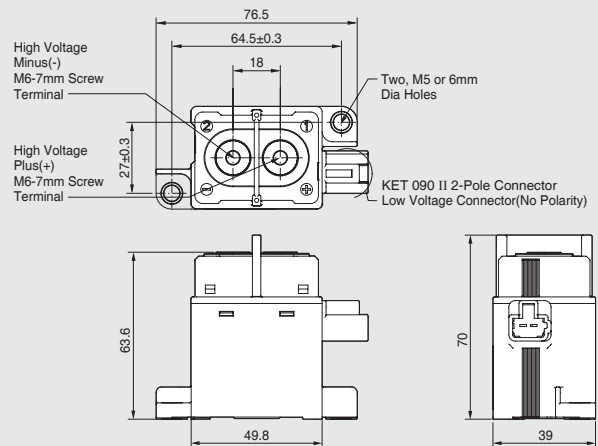

GPR250 / GPR-M250

GPR400 / GPR-M400

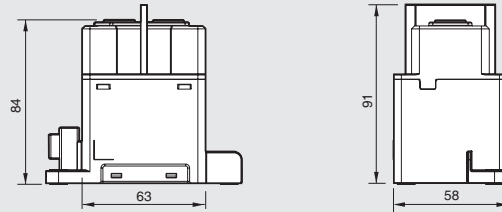
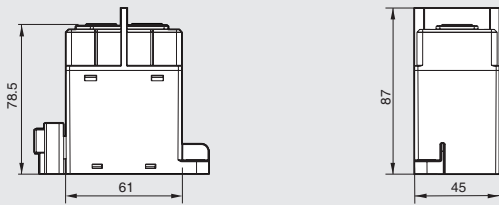
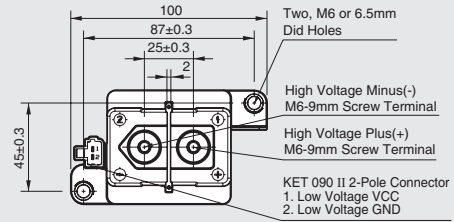
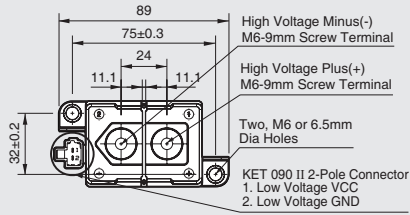

GPR-M400-A

GPR-H500-A

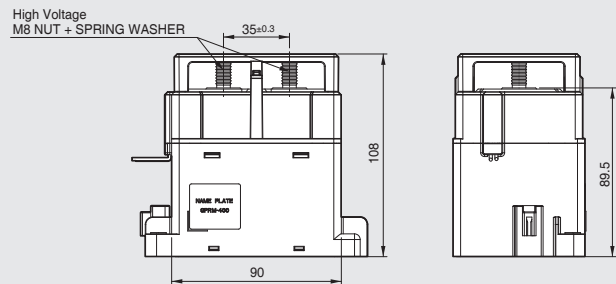
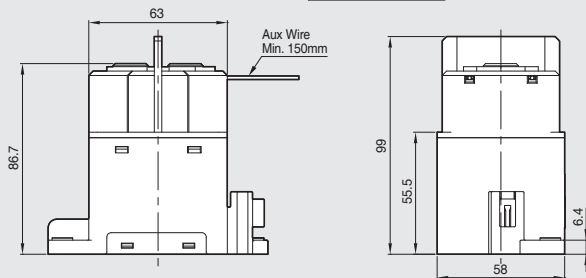
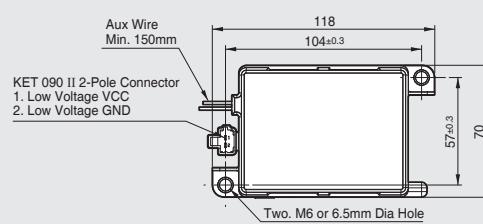
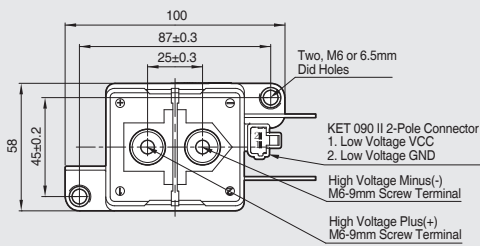

Susol
Super Solution

Metasol
Meta Solution



AC Components

You can count on us.

Customer satisfaction with world-class products and services LS is committed to excellence.

LS is implementing the 6-Sigma program with the goal of 'zero-defect' to make only the highest quality products. And to secure product reliability, we embody a high quality guarantee system by carrying out product test evaluations that are internationally recognized for their use of the most current technology.

Susol MCCB 76

Susol ACB 89

Susol Compact ACB 104

Susol VCB 113

Metasol Contactors 131

Susol Busways 149

XGIPAM 153

Susol RMU 157

Transformer 167

Susol MCCB (100~800AF)



Rating

			TD100			TD160			TS100					
Frame size	[AF]		100			160			100					
Rated current, In	[A]		16, 20, 25, 32, 40, 50, 63, 80, 100			100, 125, 160			40, 50, 63, 80, 100					
No. of poles			2, 3, 4			2, 3, 4			2, 3, 4					
Rated operational voltage, Ue	AC	[V]	690			690			690					
	DC	[V]	500			500			500					
Rated impulse withstand voltage, Uimp		[kV]	8			8			8					
Rated insulation voltage, Ui		[V]	1000			1000			1000					
Rated ultimate short-circuit breaking capacity, Icu	AC 50/60Hz	220/240V	[kA]	N	H	L	N	H	L	N	H	L		
		380/415V	[kA]	85	100	200	85	100	200	100	120	200		
	DC	440/460V	[kA]	50	85	150	50	85	150	50	85	150		
		480/500V	[kA]	50	70	130	50	70	130	50	70	130		
		525V	[kA]	30	50	65	30	50	65	42	65	85		
		660/690V	[kA]	22	35	50	22	35	50	22	35	50		
	DC	250V	[kA]	10	10	10	10	10	10	10	10	10		
		500V	[kA]	42	65	100	42	65	100	50	85	100		
	Rated service breaking capacity, Ics	AC 50/60Hz	220~525V	[%Icu]	100%	100%	100%	100%	100%	100%	100%	100%		
		DC	660/690V	[kA]	5	5	5	5	5	5	5	5		
Rated short-circuit making capacity, Icm	AC 50/60Hz	220/240V	[kA]	100%	100%	100%	100%	100%	100%	100%	100%			
		380/415V	[kA]	187	220	440	187	220	440	220	264	440		
		440/460V	[kA]	105	187	330	105	187	330	105	187	330		
		480/500V	[kA]	105	154	286	105	154	286	105	154	286		
		525V	[kA]	63	105	143	63	105	143	88	143	187		
		660/690V	[kA]	46	74	105	46	74	105	46	74	105		
Category of utilization			A			A			A					
Isolation behavior			●			●			●					
Thermal-Magnetic	● fixed-thermal, fixed-magnetic	FTU		●			●			●				
		● adjustable-thermal, fixed-magnetic	FMU	●			●			●				
		● adjustable-thermal, adjustable-magnetic	ATU	-			-			-				
Electronic	● LSI	ETS		-			-			●				
		● LSI	ETM	-			-			-				
Option	Earth-fault protection, Ig	Zone selective interlocking, ZSI		-			-			-				
		Ammeter		-			-			-				
		Communication		-			-			-				
		Connection	fixed	front-connection		●			●			●		
				rear-connection		●			●			●		
		plug-in	front-connection	rear-connection		●			●			●		
rear-connection				●			●			●				
Mechanical life		[operations]	25000			25000			25000					
Electrical life		[operations]	10000			10000			10000					
Basic dimensions, W×H×D (front connection)	3-pole	[mm]	90×140×86			90×140×86			105×160×86					
	4-pole	[mm]	120×140×86			120×140×86			140×160×86					
Weight (front connection)	3-pole	[kg]	1.5			1.5			2					
	4-pole	[kg]	1.8			1.8			2.6					
Reference standard			IEC60947-2			IEC60947-2			IEC60947-2					

* The trip unit ATU is available from 125A



TS160			TS250			TS400			TS630			TS800		
160			250			400			630			800		
(100) [*] , 125, 160			125, 160, 200, 250			300, 400			500, 630			500, 630		
2, 3, 4			2, 3, 4			2, 3, 4			2, 3, 4			2, 3, 4		
690			690			690			690			690		
500			500			500			500			500		
8			8			8			8			8		
1000			1000			1000			1000			1000		
N	H	L	N	H	L	N	H	L	N	H	L	N	H	L
100	120	200	100	120	200	100	120	200	100	120	200	100	120	200
50	85	150	50	85	150	65	85	150	65	85	150	65	100	150
50	70	130	50	70	130	65	85	130	65	85	130	65	100	130
42	65	85	42	65	85	42	65	85	42	65	85	42	85	100
22	35	50	22	35	50	22	35	50	22	35	50	22	35	50
10	10	10	10	10	10	10	20	35	10	20	35	10	20	35
50	85	100	50	85	100	50	85	100	50	85	100	50	85	100
50	85	100	50	85	100	50	85	100	50	85	100	50	85	100
100%	100%	100%	100%	100%	100%	100%	100%	100%	100%	100%	100%	100%	100%	100%
5	5	5	5	5	5	10	12	12	10	12	12	10	20	20
100%	100%	100%	100%	100%	100%	100%	100%	100%	100%	100%	100%	100%	100%	100%
220	264	440	220	264	440	220	264	440	220	264	440	220	264	440
105	187	330	105	187	330	143	187	330	143	187	330	143	220	330
105	154	286	105	154	286	143	187	286	143	187	286	143	220	286
88	143	187	88	143	187	88	143	187	88	143	187	88	187	220
46	74	105	46	74	105	46	74	105	46	74	105	46	74	105
17	17	17	17	17	17	17	40	74	17	40	74	17	40	74
A			A			A			A			A		
●			●			●			●			●		
●			●			●			●			●		
●			●			●			●			●		
●			●			●			●			●		
●			●			●			●			●		
●			●			●			●			●		
-			-			●			●			●		
-			-			●			●			●		
-			-			●			●			●		
-			-			●			●			●		
-			-			●			●			●		
●			●			●			●			●		
●			●			●			●			●		
●			●			●			●			●		
●			●			●			●			●		
25000			25000			20000			20000			10000		
10000			10000			6000			6000			3000		
105×160×86			105×160×86			140×260×110			140×260×110			210×320×135		
140×160×86			140×160×86			186.5×260×110			186.5×260×110			280×320×135		
2			2			5.4			5.4			15.1		
2.6			2.6			7.2			7.2			19.6		
IEC60947-2			IEC60947-2			IEC60947-2			IEC60947-2			IEC60947-2		

Susol MCCB Selection method

Susol MCCB selects ratings of the body and the trip device for circuits breakers, respectively, when selecting products.

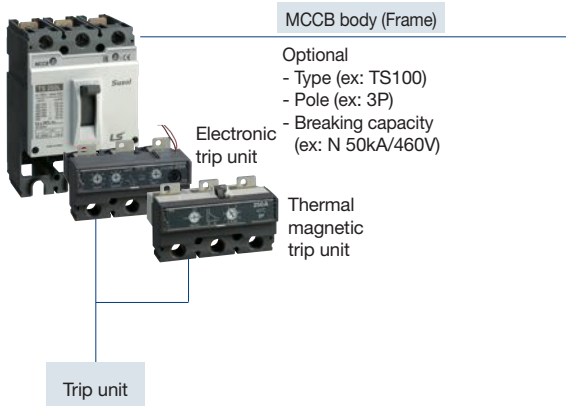

MCCB body



Type		TD100			TD160		
Icu size	[AF]	100			160		
No. of poles	[Pole]	2, 3, 4			2, 3, 4		
Rated ultimate short-circuit breaking capacity, Icu	Type	N	H	L	N	H	L
	660/690V [kA]	5	8	10	5	8	10
	525V [kA]	22	35	50	22	35	50
	480/500V [kA]	30	50	65	30	50	65
	440/460V [kA]	50	70	130	50	70	130
380/415V [kA]		50	85	150	50	85	150
	220/240V [kA]	85	100	200	85	100	200

Trip units

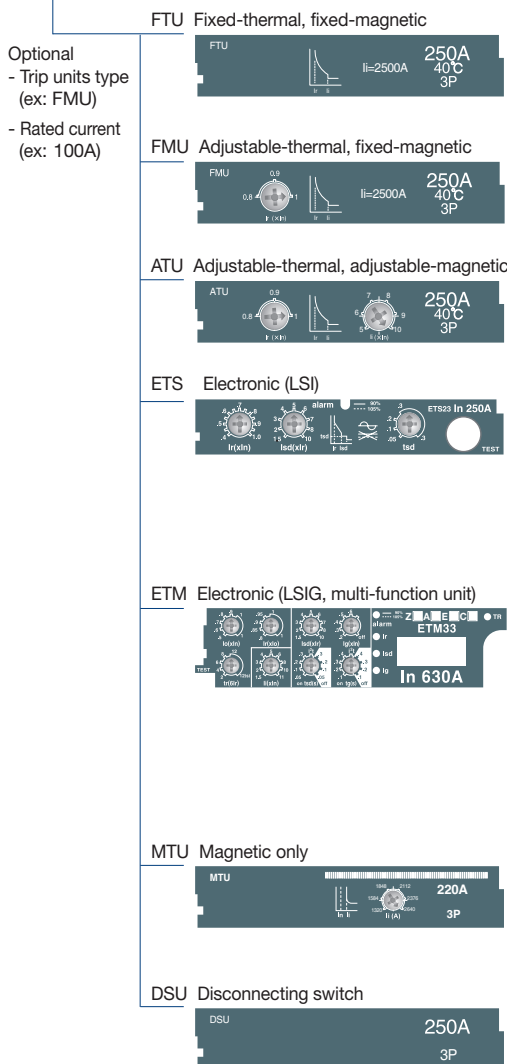

FTU	Rated current, In	Fixed	16, 20, 25, 32, 40, 50, 63, 80, 100A	100, 125, 160A
	Instantaneous trip current, Ii	Fixed	400A (In=32A or less) 10×In (In=40A or more)	10×In
FMU	Rated current, In	Adjustable	16, 20, 25, 32, 40, 50, 63, 80, 100A	100, 125, 160A
		Adjustment range	(0.8-0.9-1)×In	(0.8-0.9-1)×In
ATU	Rated current, In	Adjustable	-	-
		Adjustment range	-	-
ETS	Instantaneous trip current, Ii	Fixed	400A (In=32A or less) 10×In (In=40A or more)	10×In
	Rated current, In	Adjustable	-	-
ETM		Adjustment range	-	-
	Instantaneous trip current, Ii	Adjustable	-	-
MTU	Rated current, In	Adjustable	-	-
		Adjustment range	-	-
DSU	Long time trip current, Ir	Primary adjustment	-	-
		Secondary adjustment	-	-
DSU	Long time trip time, Ir	Adjustable	-	-
	Short time characteristics	Current adjustment	-	-
DSU		Time adjustment	-	-
	Instantaneous trip current, Ii	Adjustable	-	-
DSU	Additional function	Standard	-	-
		Optional	-	-
DSU	Type		-	-
	Number of pole	[Pole]	-	-
DSU	Rated current (Energizing current)	Unprotected	-	-
	Instantaneous trip current, Ii	Adjustable	-	-

※ ATU can be adjustable for 125A or more.

DSU is a device from which all protection (trip) function have



TS100			TS160			TS250			TS400			TS630			TS800		
100			160			250			400			630			800		
2, 3, 4			2, 3, 4			2, 3, 4			2, 3, 4			2, 3, 4			2, 3, 4		
N	H	L	N	H	L	N	H	L	N	H	L	N	H	L	N	H	L
10	15	20	10	15	20	10	15	20	10	20	35	10	20	35	10	20	35
22	35	50	22	35	50	22	35	50	22	35	50	22	35	50	22	35	50
42	65	85	42	65	85	42	65	85	42	65	85	42	65	85	42	85	100
50	70	130	50	70	130	50	70	130	65	85	130	65	85	130	65	100	130
50	85	150	50	85	150	50	85	150	65	85	150	65	85	150	65	100	150
100	120	200	100	120	200	100	120	200	100	120	200	100	120	200	100	120	200

40, 50, 63, 80, 100A			100, 125, 160A			125, 160, 200, 250A			300, 400A			500, 630A			700, 800A		
10×In						10×In						10×In					
40, 50, 63, 80, 100A			100, 125, 160A			125, 160, 200, 250A			300, 400A			500, 630A			800A		
(0.8-0.9-1)×In						(0.8-0.9-1)×In						(0.8-0.9-1)×In					
10×In						10×In						10×In					
-			125, 160A			125, 160, 200, 250A			300, 400A			500, 630A			800A		
(0.8-0.9-1)×In						(0.8-0.9-1)×In						(0.8-0.9-1)×In					
(5-6-7-8-9-10)×In						(5-6-7-8-9-10)×In						(5-6-7-8-9-10)×In					
In=40, 80A			In=40, 80, 160A			In=40, 80, 160, 250A			In=160, 250, 400A			In=160, 250, 400, 630A			In=630, 800A		
Ir=(0.4~1)×In : Step 13						Ir=(0.4~1)×In : Step 13						Ir=(0.4~1)×In : Step 13					
(1.5~10)×Ir : Step 9						(1.5~10)×Ir : Step 9						(1.5~10)×Ir : Step 9					
50, 100, 200, 300ms : Step 4						50, 100, 200, 300ms : Step 4						50, 100, 200, 300ms : Step 4					
11×In						11×In						11×In					
-			-			-			In=160, 250, 400A			In=160, 250, 400, 630A			In=630, 800A		
-						-						Total 30 steps					
-						-						Io=(0.5~1)×In : Step 6					
-						-						Ir=(0.8~1)×Io : Step 5					
-						-						2, 4, 6, 8, 12sec(at 6×Ir) : Step 5					
-						-						(1.5~10)×Ir : Step 9					
-						-						50, 100, 200, 300ms : Step 4					
-						-						(1.5~11)×Ir : Step 9					
-						-						Show cause of accident (LED)					
-						-						Ammeter(A), Ground fault protection(E), Communication(C), Optional protection(Z)					
N	H	L	N	H	L	N	H	L	N	H	L	N	H	L	N	H	L
3			3			3			3			3			3		
1.6, 3.2, 6.3, 12, 20, 32, 50, 63A			32, 50, 63, 100, 160			100, 160, 220A			320A			500A			630A		
(6~12)×In : Step 6						(6~12)×In : Step 6						(6~12)×In : Step 6					

been removed in order to use the breaker for opening and closing.

Susol MCCB (1600AF)







Rating

Type				
Ampere frame				
Pole				
Rated current,(A)	In	-5~40°C		
		50°C		
		65°C		
Rated insulation voltage, (V)	Ui			
Rated impulse withstand voltage, (kV)	Uimp			
Rated operational voltage, (V)	Ue	AC50/60Hz		
		DC		
Rated short-circuit breaking capacity				
IEC60947-2 AC50/60Hz (sym)	Rated ultimate short-circuit breaking capacity, (kA) (Icu)	220/240V		
		380/415V		
		440/460V		
		480/500V		
		660/690V		
	DC	250V 2P		
		500V 2P		
		750V 3P		
	Rated service	%Icu		
	breaking capacity (Ics)			
Rated short-circuit making capacity (kA) (Icw)	AC50/60Hz	1s		
		3s		
Overriding instantaneous protection		kA peak		
Isolation				
Category				
(Life cycle)	Mechanical life (operations)			
	Electrical life (operations)	440V	In/2	
			In	
	690V	In/2		
In				
Pollution degree				
Dimension (mm)		3-pole		
(W×H×D)		4-pole		
Weight (kg)	3-pole			
	4-pole			

TS1000			TS1250		TS1600	
TS1000			TS1250		TS1600	
1000			1250		1600	
3, 4			3, 4		3, 4	
800, 1000			1250		1600	
800, 1000			1250		1560	
800, 1000			1240		1420	
1000			1000		1000	
8			8		8	
690			690		690	
-			-		-	
N	H	L	N	H	N	H
55	75	200	55	75	55	75
50	70	150	50	70	50	70
50	65	130	50	65	50	65
40	50	100	40	50	40	50
35	45	-	35	45	35	45
-	-	-	-	-	-	-
-	-	-	-	-	-	-
-	-	-	-	-	-	-
100%	75%	100%	100%	75%	100%	75%
25		12	25		25	
-		-	-		-	
50		30	50		50	
○		-	○		○	
B		A	B		B	
10000		4000	10000		10000	
6000		4000	5000		5000	
5000		3000	4000		2000	
4000		3000	3000		2000	
2000		2000	2000		1000	
3		-	3		3	
			210×327×152.5			
			280×327×152.5			
			13			
			16.8			

* Power. Reverse connection of the load side is possible, but use it for normal connection for maintenance, inspection and safety in use.
 * 4-pole neutral electrode (N phase) is a method that is blocked after line input.

Overview

Classification	N type	A type	P type	S type
Externals				
Current protection	• L / S / I / G / Thermal	• L / S / I / G / Thermal • ZSI(Protective coordination) • Earth leakage (Option)	• L / S / I / G / Thermal(Continuous) • ZSI(Protective coordination) • Earth leakage(Option)	• P type
Other protection	-		• Over/Under current • Over/Under frequency • Unbalance(Voltage/Current) • Reverse power	• P type
Measurement function	-	• Current (R / S / T / N)	• 3 Phase Voltage/Current RMS/Vector • Power(P, Q, S), PF(3-Phase) • Energy(Positive/Negative) • Frequency, Demand	• 3 Phase Voltage/Current RMS/Vector • Power(P, Q, S), PF(3-Phase) • Energy(Positive/Negative) • Frequency, Demand • Voltage/Current harmonics (1st~63th) • 3 Phase Waveforms • THD, TDD, K-Factor
Fine adjustment	-	-	• Fine adjustment for long/short time delay/instantaneous/ ground	• P type
Pre Trip Alarm	-	-	• Overload protection relays : DO (Alarm) (Ground fault is not available when using Pre trip alarm)	• P type
Digital Output	-	• 3DO (Fixed) • L, S/I, G Alarm	• 3DO (Programmable) • Trip, Alarm, General	• P type
IDMTL setting	-	-	• Compliance with IEC60255-3 SIT, VIT, EIT, DT	• P type
Communication	-	• Modbus/RS-485 • Profibus-DP	• Modbus / RS-485 • Profibus-DP	• Modbus / RS-485 • Profibus-DP
Power supply	• Self Power -Power source works over 25% of current of In (one pole)	• Self Power - Power source works over 25% of current of In (one pole) - External power source are required for comm. • AC/DC 100~250V • DC 24~60V	• AC/DC 100~250V • DC 24~60V	• AC/DC 100~250V • DC 24~60V
RTC timer	• Available	• Available	• Available	• Available
LED for trip info.	• Long time delay • Short time delay/Instantaneous • Ground fault	• N type	• N type	• N type
Fault recording	-	• 10 records (Fault/Current/Date and Time)	• 256 records (Fault/Current/Date and Time)	• 256 records • Last fault wave recording (3 Phase)
Event recording	-	-	• 256 records(Content, Status, Date)	• P type
Operating button	• Reset button	• Reset, Menu Up/Down, Left/Right, Enter	• A type	• A type

Each type of OCR has a built-in battery.

1. Battery life

- 1) LED is off: 14 ~ 28 years
- 2) 1 LED is continuously on or flashing: 7 ~ 14 days

2. OCR current detectable range

- 1) 10 : 20% or more of the rated current (In) ratio to the value of In regardless of the setting value of Iu and Ir)
- 2) 30 : 12% or more of the rated current (In)

* RTC Timer : Real Time Clock Timer (required for time alarm and hot start function when event occur)

Susol Switch-Disconnectors (100~800AF)

Electrical characteristics / Trip unit - DSU

Wiring breaker has the same appearance as circuit breakers but has switching function without protection function. Therefore, its basic accessories are the same accessories for circuit breakers.



Rating

				TD100NA	TD160NA		TS100NA	
Frame size				100	160	160	100	
Conventional thermal current, I _{th}				100	100	160	100	
No. of poles				2, 3, 4	2, 3, 4	2, 3, 4	2, 3, 4	
Rated operational voltage, U _e	AC			690	-	690	690	
	DC			500	500, 750, 1100	500, 750, 1100	500	
Rated operational current, I _e				100	-	160	100	
Rated impulse withstand voltage, U _{imp}				8	8	8	8	
Rated insulation voltage, U _i	AC			750	-	750	750	
	DC			-	1100	1100	-	
Rated short-circuit making capacity, I _{cm}	AC			3.1	-	3.1	2.8	
	DC			-	1.92	1.92	-	
Rated short-time withstand current, I _{cw}	AC	1s	[A rms]	2200	-	2200	2000	
		3s	[A rms]	2200	-	2200	2000	
		20s	[A rms]	960	-	960	690	
	DC	1s	[A rms]	-	1920	1920	-	
Isolation behavior				●	●	●	●	
Trip unit (Release)								
	● Disconnector unit			DSU	●	●	●	●
Connection	Fixed	Front-connection		●	●	●	●	●
		Rear-connection		●	●	●	●	●
	Plug-in	Front-connection		●	●	●	●	●
		Rear-connection		●	●	●	●	●
Mechanical life				25000	-	25000	25000	
Electrical life @415 V	AC		[Operations]	10000	-	10000	10000	
	DC		[Operations]	-	1500	1000	-	
Basic dimensions, W×H×D (Front connection)	3-pole		[mm]	90×140×86	90×140×86		105×160×86	
	4-pole		[mm]	120×140×86	120×140×86		140×160×86	
Weight (Front connection)	3-pole		[kg]	1.5	1.5		2	
	4-pole		[kg]	1.8	1.8		2.6	
Reference standard				IEC60947-3	IEC60947-3		IEC60947-3	

Note)

1. Rating of TD160NA is 100,160A
2. Rating of TS250NA is 200, 250A
3. DC Rating of TS630NA is 500A

DC Exemplary circuit diagrams

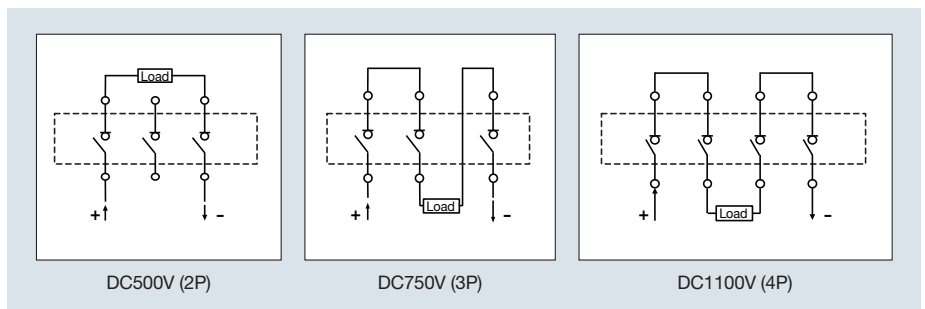



	TS160NA	TS250NA		TS400NA	TS630NA	TS800NA
	160	250	250	400	630	800
	160	200	250	400	630 (500) ^{Note 3)}	800
	2, 3, 4	2, 3, 4	2, 3, 4	2, 3, 4	2, 3, 4	2, 3, 4
	690	-	690	690	690	690
	500	500, 750, 1100	500, 750, 1100	500	500, 750, 1100	500, 750, 1100
	160	-	250	400	630	800
	8	8	8	8	8	8
	750	-	750	750	750	750
	-	1100	1100	1100	1100	1100
	3.6	-	4.9	7.1	8.5	12
	-	3.0	3.0	6.0	6.0	9.6
	2500	-	3500	5000	6300	8000
	2500	-	3500	5000	6300	8000
	960	-	1350	1930	2320	2560
	-	3000	3000	6000	6000	9600
	●	●	●	●	●	●
	●	●	●	●	●	●
	●	●	●	●	●	●
	●	●	●	●	●	●
	●	●	●	●	●	●
	●	●	●	●	●	●
	25000	-	25000	20000	20000	10000
	10000	10000	10000	6000	6000	3000
	-	1000	1000	1000	1000	500
	105×160×86	105×160×86		140×260×110	140×260×110	210×320×135
	140×160×86	140×160×86		186.5×260×110	186.5×260×110	280×320×135
	2	2		5.4	5.4	15.1
	2.6	2.6		7.2	7.2	19.6
	IEC60947-3	IEC60947-3		IEC60947-3	IEC60947-3	IEC60947-3

Trip unit appearance



Susol MCCB

Dimensions of MCCB body

TD100, 160

[mm]

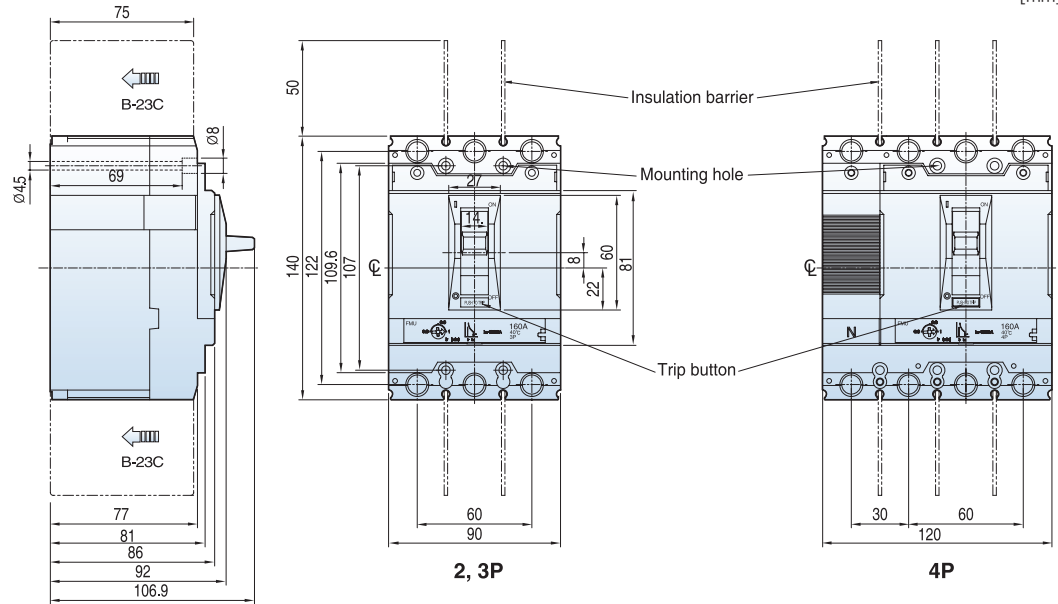

Terminal section

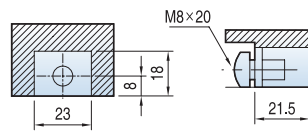

Conductor

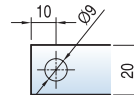

Panel drilling

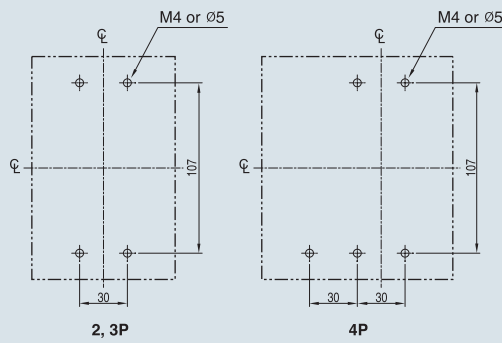

Front panel cutting

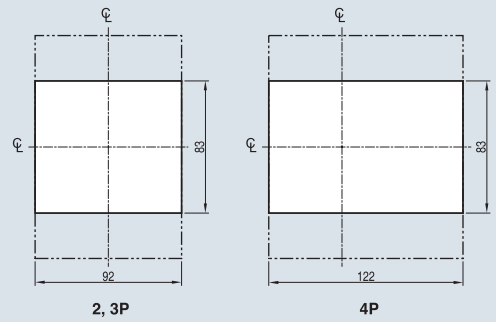

TS100, 160, 250

[mm]

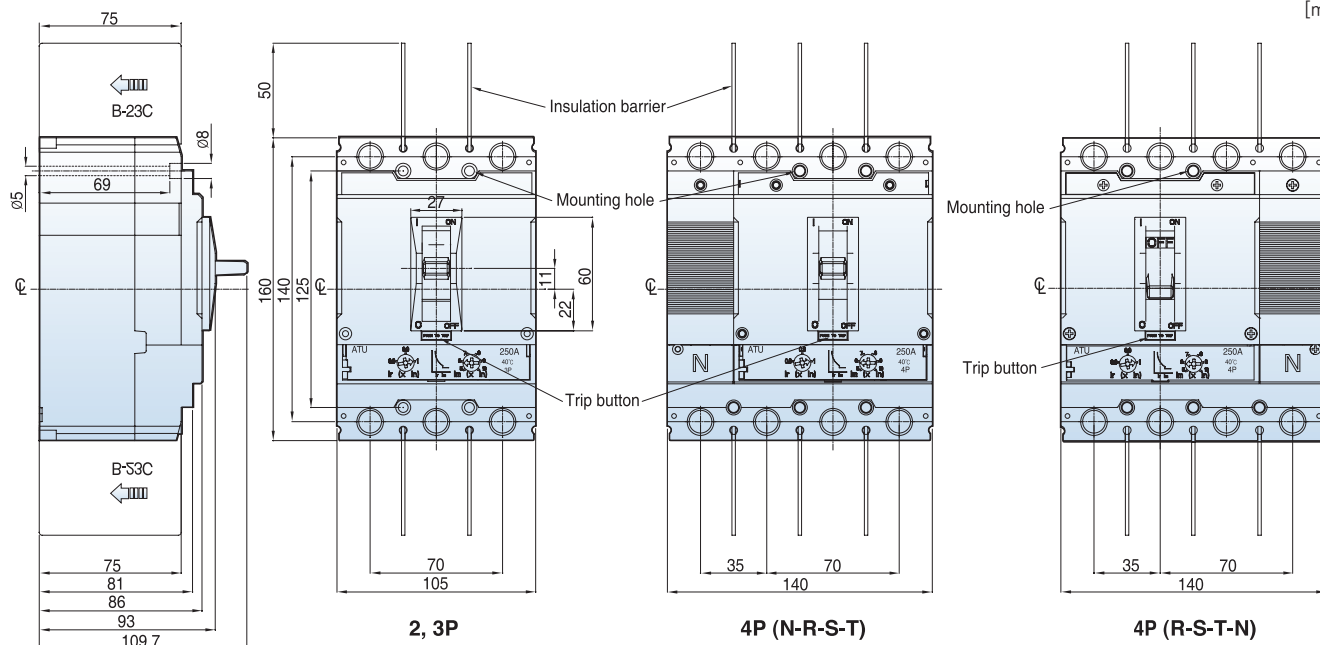

Terminal section

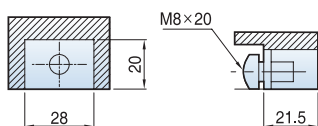

Conductor

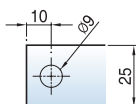

Panel drilling

Front panel cutting

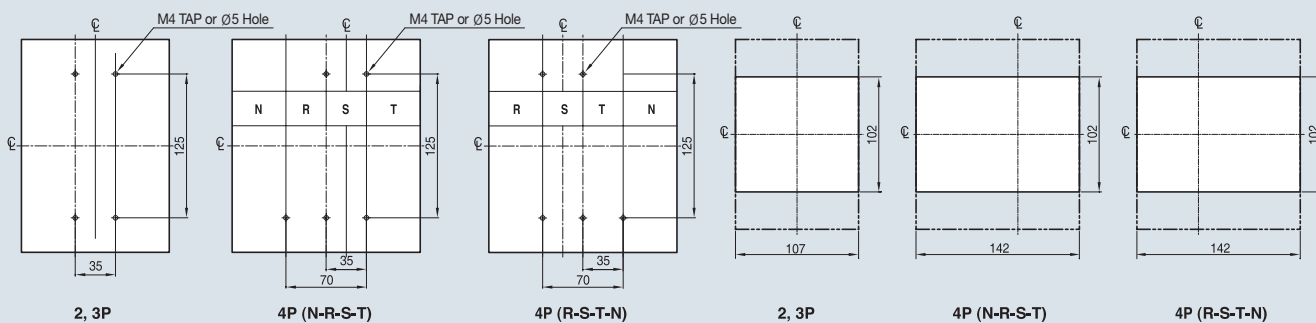

Susol MCCB

Dimensions of MCCB body

TS400, 630

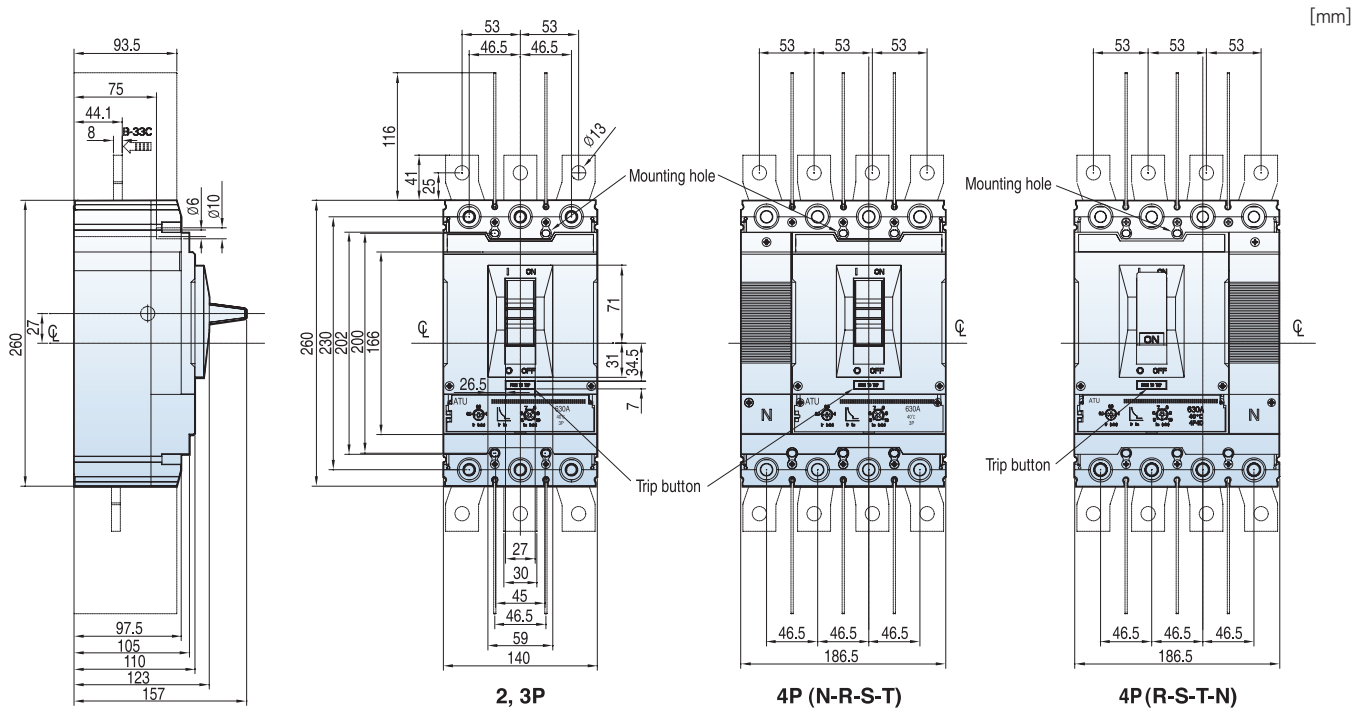

Terminal section

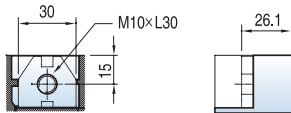

Conductor

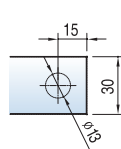

Panel drilling

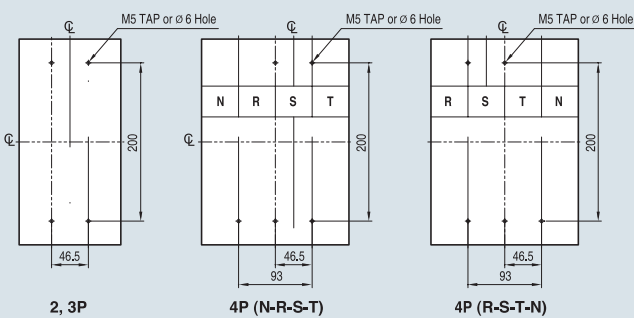

Front panel cutting

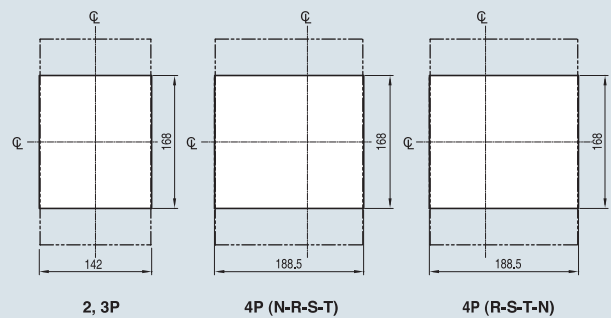

TS800

[mm]

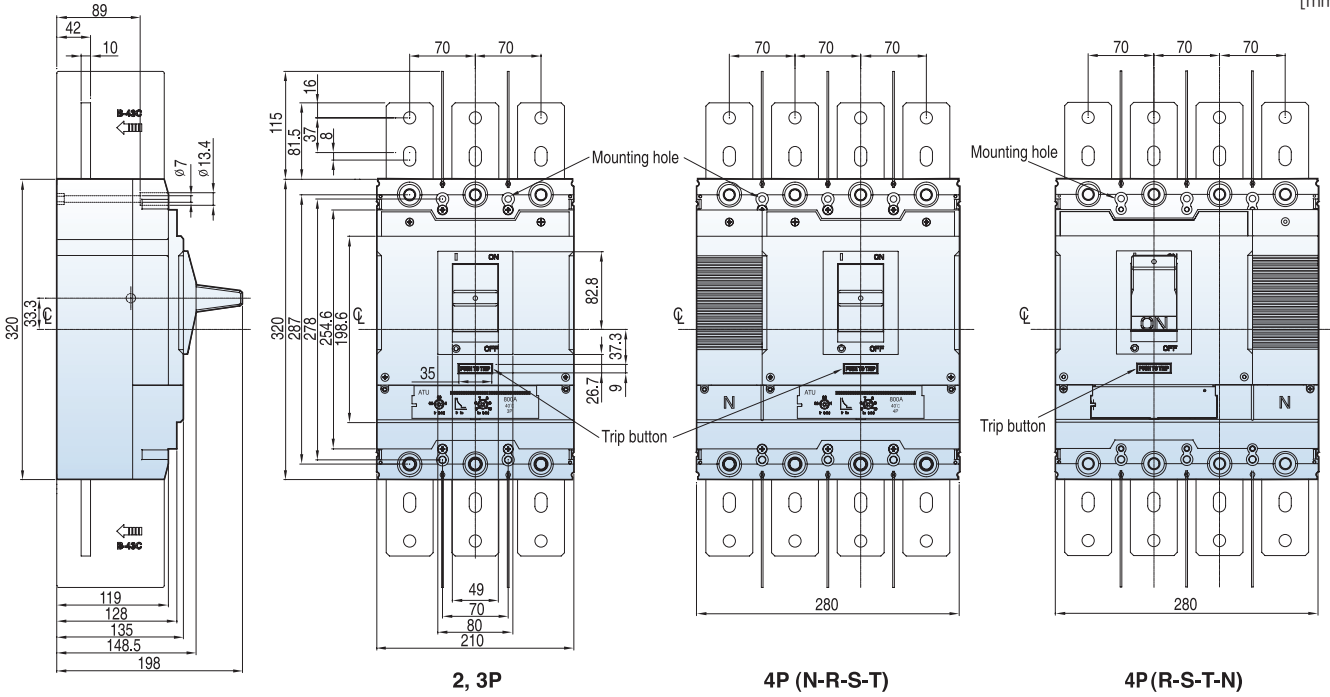

Terminal section

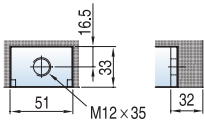

Conductor

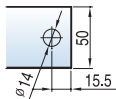

Panel drilling

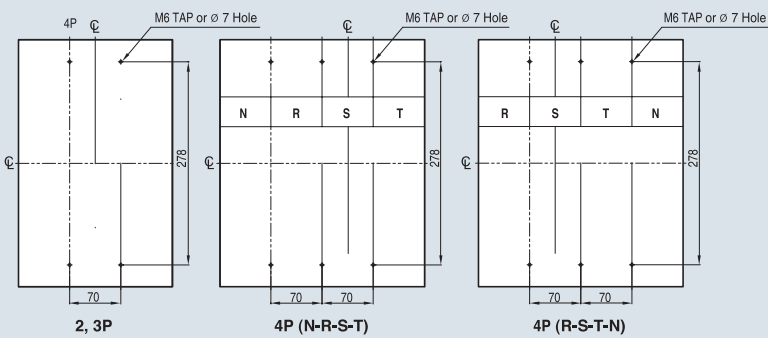

Front panel cutting

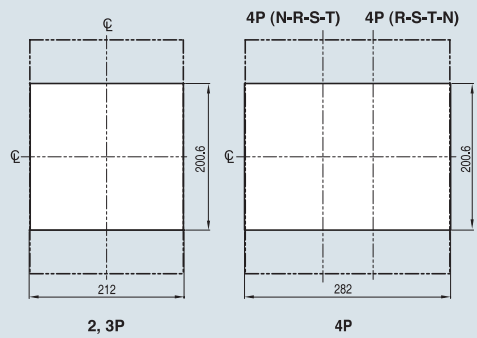

Susol MCCB

TS 1000, 1250, 1600A Dimensions

Front Type

[mm]

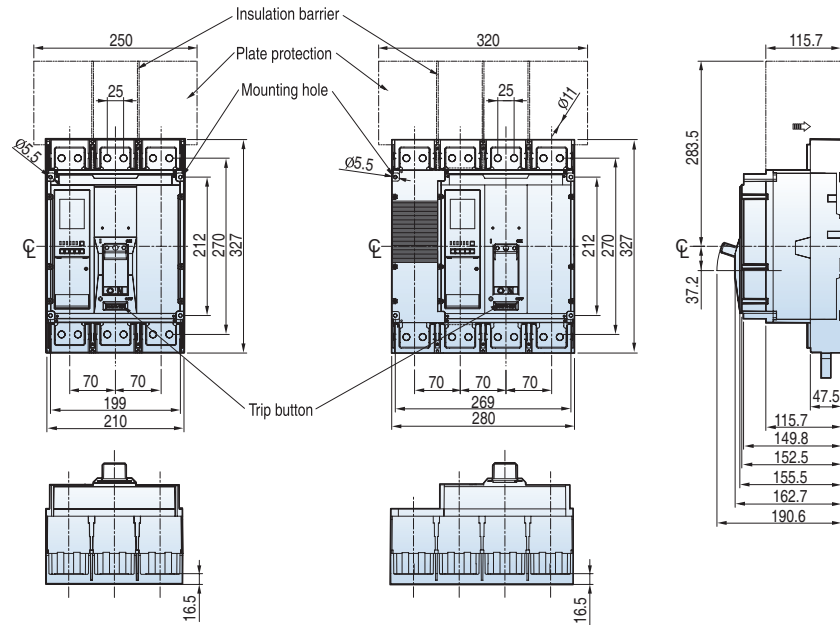

Panel drilling

ON BACKPLATE

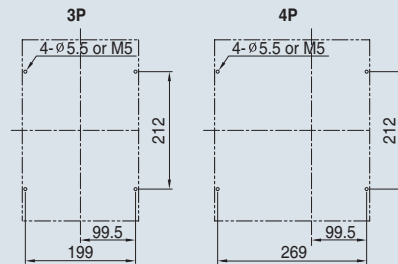

ON RAILS

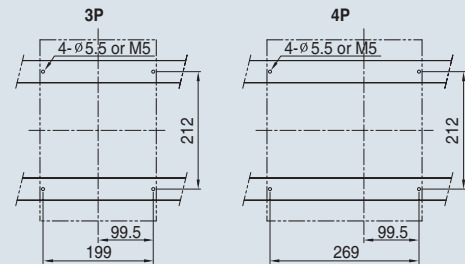

Front panel cutting

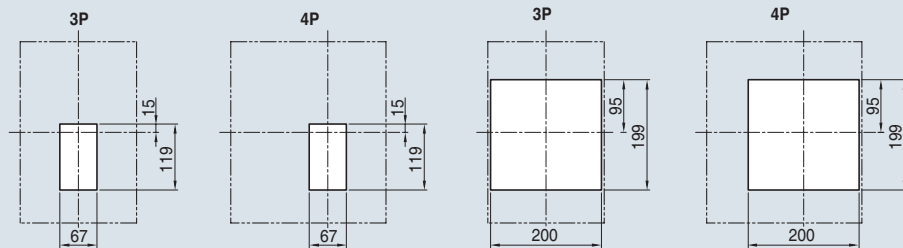

ACB

Air Circuit Breakers

Premium Susol ACB meets your demands for high breaking capacity, full line-up, and optimized panel size. Various accessories and connection methods create a user-friendly handling. Susol ACB provides total solution with an advanced trip relay for measurement, diagnosis, analysis, and communication as well as protective functions for absolute protective coordination and electric power monitoring system.

- KS certified (KS C 4620)
- KEPIC(Nuclear rating) and quality (Q-class) certified.
- LR, ABS, DNV, KR, BV, GL, RINA, NK certified
- Maximum breaking capacity : 150kA (6300AF at 500Vac)
- 2000/4000/6300AF, 3 Ampere Frame Sizes
- N phase current conducting capacity : 100%
- Offers variety of accessories including digital trip relay with metering/ measuring/analysis/communication functions.
- Rated impulse voltage (Uimp) : 12kV

Ratings

- In : 630~6300AF 3, 4 poles, fixed or draw-in/out type
- Ics : 85/100/150kA, 500Vac rating
- Icw : 65/85/100kA

LS has passed and achieved Korea's highest and toughest KS rating (KS C 8325 KS C 4620) to prove its safety and function-ality in ACB market.



Susol ACB (~6300AF)

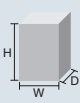

Rating

Type		
Ampere frame	(AF)	
Rated current(A)	(In max)	at 40°C
Setting current (A) *	Control trip relay (... × In max)	
Rated current of neutral pole (A)		
Rated insulation voltage(V)	(Ui)	
Rated operational voltage(V)	(Ue)	
Rated impulse withstand voltage (kV)	(Uimp)	
Frequency(Hz)		
Number of poles (P)		
Rated breaking capacity (kA sym)	(Icu)	220V/230V/380V/415V
AC 50/60Hz		460V/480V/500V
		550V/600V/690V
Rated service breaking capacity (kA)	(Ics)	... % × Icu
Rated making capacity (kA peak)	(Icm)	220V/230V/380V/415V
AC 50/60Hz		460V/480V/500V
		550V/600V/690V
Rated short-time withstand current (kA)	(Icw)	1 sec
		2 sec
		3 sec
Operating time (ms)	Maximum total breaking time	
	Maximum closing time	
Life cycle (time)	Mechanical	
	Electrical	
Connections **	Draw-out / Fixed	Horizontal connection
		Vertical connection
		Front connection
		Mixed connection
Weight (kg) (3P/4P)	Draw-out type	Main body
		(With cradle)
		Cradle only
	Fixed type	Motor charging type
		Manual charging type
External dimensions (mm) (H×W×D)		Draw-out
		type
		Fixed type
Trip relay		
Certificate & Approval		
Marine classification		

AH-D					
AH-06D	AH-08D	AH-10D	AH-13D	AH-16D	AH-20D
630	800	1000	1250	1600	2000
200	400				
400	630	1000	1250	1600	2000
630	800				
(0.4 ~ 1.0) × In max					
400	400				
630	630	1000	1250	1600	2000
	800				
1,000					
690					
12					
50/60					
3/4					
85					
85					
65					
100%					
187					
187					
143					
65					
60					
50					
40					
80					
20,000					
5,000					
		●			-
		○			●
		○			-
		○			-
			63/74	70/85	
			61/72	68/83	
			29/32	33/40	
			34/44	38/47	
			32/42	36/45	
430×334×375					
430×419×375					
300×300×295					
300×385×295					
N, A, P, S type					
KS / KEMA / KERI / GOST / CCC					
LR, ABS, DNV, KR, BV, GL, RINA, NK					

* Refer to trip relay specification. ** ●: Standard, ○: Option

Note) 1. Life time means not guarantee, but limitation.

Quality guarantee: On/Off frequency on the basis of IEC60947-2 within the term of guarantee

2. In case of Marine ACB, please contact us.

3. The use of AN-D, AS-D, AH-D and AS-F in IT systems is limited to 500 V network voltage.

4. AH-20D, AH-40E types are equipped with vertical-only terminals.



AH-E								
AH-06E	AH-08E	AH-10E	AH-13E	AH-16E	AH-20E	AH-25E	AH-32E	AH-40E
630	800	1000	1250	1600	2000	2500	3200	4000
630	800	1000	1250	1600	2000	2500	3200	4000
(0.4 ~ 1.0) × In max								
630	800	1000	1250	1600	2000	2500	3200	4000
1,000								
690								
12								
50/60								
3/4								
100								
100								
85								
100%								
220								
220								
187								
85								
75								
65								
40								
80								
15,000								
5,000								
●								-
○								●
○								-
○								-
87/103								107/139
85/101								102/145
44/55								65/85
44/55								61/81
42/53								60/80
430×412×375								
430×527×375								
300×378×295								
300×493×295								
N, A, P, S type								
KS / KEMA / KERI / GOST / CCC								
LR, ABS, DNV, KR, BV, GL, RINA, NK								

AH-G		
AH-40G	AH-50G	AH-63G
4000	5000	6300
4000	5000	6300
(0.4 ~ 1.0) × In max		
4000	5000	6300
1,000		
690		
12		
50/60		
3/4		
150		
150		
100		
100%		
330		
330		
220		
100		
85		
75		
40		
80		
10,000		
2,000		
○		
●		
-		
-		
181/223		186/230
179/221		184/228
97/117		102/124
98/123		103/130
96/121		101/128
460×785×375		
460×1015×375		
300×751×295		
300×981×295		
N, A, P, S type		
KS / KEMA / KERI / GOST / CCC		
LR, ABS, DNV, KR, BV, GL, RINA, NK		

※ Derating of the rated current is required according to the ambient temperature around the breaker in a panel if it is higher than the reference value. (See pages 123 to 126)

Susol ACB (up to 1150Vac)



Rating

Characteristics	
Number of poles	(P)
Rated operational voltage (Ue)	(Vac)
Rated insulation voltage (Ui)	(V)
Rated impulse withstand voltage (Uimp)	(kV)
Version	
Suitability for isolation	
Degree of pollution	IEC60661-1
Certification	

Brand name	
Model	
Ampere frame	(AF)
Rated current (In max)	(A)
Rated ultimate breaking capacity (Icu)	1150V (kA)
	1000V (kA)
	900V (kA)
	800V (kA)
Rated service breaking capacity (Ics)	(% Icu)
Rated short-time withstand current (Icw)	1s (kA)
	3s (kA)
Rated making capacity (Icm)	(kA)
Selectivity category (according to IEC 60947-2)	
Operation time (ms)	Total Breaking time < Icw
	≥ Icw
	Closing time

Mechanical and Electrical Life cycle	
Endurance (times) (Without maintenance)	Mechanical
	Electrical

Dimension and Weight			
Weight (3P/4P)	Draw-out	Without cradle	(kg)
		With cradle	(kg)
External Dimensions (H×W×D)	Fixed		(kg)
	Draw-out	3P(4P)	(mm)
	Fixed	3P(4P)	(mm)

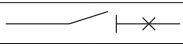
3 / 4
~ 1150
1250
12kV
Fixed / Withdrawable

3
CB certification according to IEC 60947-2

Susol AV					
AV-06D	AV-08D	AV-10D	AV-13D	AV-16D	AV-20D
630	800	1000	1250	1600	2000
200	400	630	630	800	1000
400	630	800	800	1000	1250
630	800	1000	1000	1250	1600
			1250	1600	2000
30					
42					
50					
50					
100					
30					
30					
63					
B					
max. 75					
max. 25					
max. 80					
12,500					
1,000					
37/45					
70/85					
34/44					
430×334(419)×375					
300×300(385)×295					

* AV series are applicable for IT system



3 / 4

~ 1150

1250

12kV

Fixed / Withdrawable

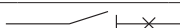

3

CB certification according to IEC 60947-2

Susol AV

AV-06E	AV-08E	AV-10E	AV-13E	AV-16E	AV-20E	AV-25E	AV-32E	AV-40E
630	800	1000	1250	1600	2000	2500	3200	4000
400	400	630	630	800	1000	1250	1600	2000
630	630	800	800	1000	1250	1600	2000	2500
	800	1000	1000	1250	1600	2000	2500	3200
			1250	1600	2000	2500	3200	4000

50

65

75

75

100

50

50

105

B

max. 75

max. 25

max. 80

12,500

1,000

44/49

88/104

45/56

430×412(527)×375

300×378(493)×295

Susol ACB (up to 900Vac)



Rating

Characteristics	
Number of poles	(P)
Rated operational voltage (Ue)	(Vac)
Rated insulation voltage (Ui)	(V)
Rated impulse withstand voltage (Uimp)	(kV)
Version	
Suitability for isolation	
Degree of pollution	IEC60661-1
Certification	

Brand name	
Model	
Ampere frame	(AF)
Rated current (In max)	(A)
Rated ultimate breaking capacity (Icu)	900V (kA)
Rated service breaking capacity (Ics)	800V (kA)
Rated short-time withstand current (Icw)	1s (kA)
	3s (kA)
Rated making capacity (Icm)	(kA)
Selectivity category (according to IEC 60947-2)	
Operation time (ms)	Total Breaking time < Icw
	≥ Icw
	Closing time

Mechanical and Electrical Life cycle	
Endurance (times) (Without maintenance)	Mechanical
	Electrical

Dimension and Weight			
Weight (3P/4P)	Draw-out	Without cradle	(kg)
		With cradle	(kg)
	Fixed		(kg)
External Dimensions (H×W×D)	Draw-out	3P(4P)	(mm)
	Fixed	3P(4P)	(mm)

3 / 4
~ 900
1000
12kV
Fixed / Withdrawable
3
CB certification according to IEC 60947-2

Susol AW					
AW-06D	AW-08D	AW-10D	AW-13D	AW-16D	AW-20D
630	800	1000	1250	1600	2000
200	400	630	630	800	1000
400	630	800	800	1000	1250
630	800	1000	1000	1250	1600
			1250	1600	2000
42					
50					
100					
42					
42					
88.2					
B					
max. 75					
max. 25					
max. 80					

20,000
1,000
37/45
70/85
34/44
430×334(419)×375
300×300(385)×295



3 / 4

~ 900

1000

12kV

Fixed / Withdrawable



3

CB certification according to IEC 60947-2

Susol AW

AW-06E	AW-08E	AW-10E	AW-13E	AW-16E	AW-20E	AW-25E	AW-32E	AW-40E
630	800	1000	1250	1600	2000	2500	3200	4000
400	400	630	630	800	1000	1250	1600	2000
630	630	800	800	1000	1250	1600	2000	2500
	800	1000	1000	1250	1600	2000	2500	3200
			1250	1600	2000	2500	3200	4000

50

65

100

50

50

105

B

max. 75

max. 25

max. 80

10,000

1,000

44/49

88/104

45/56

430 × 412(527) × 375

300 × 378(493) × 295

This diagram is based on "CONNECTED" position of a circuit breaker and Opening, Motor charging, Releasing of locking plate should be normal condition.

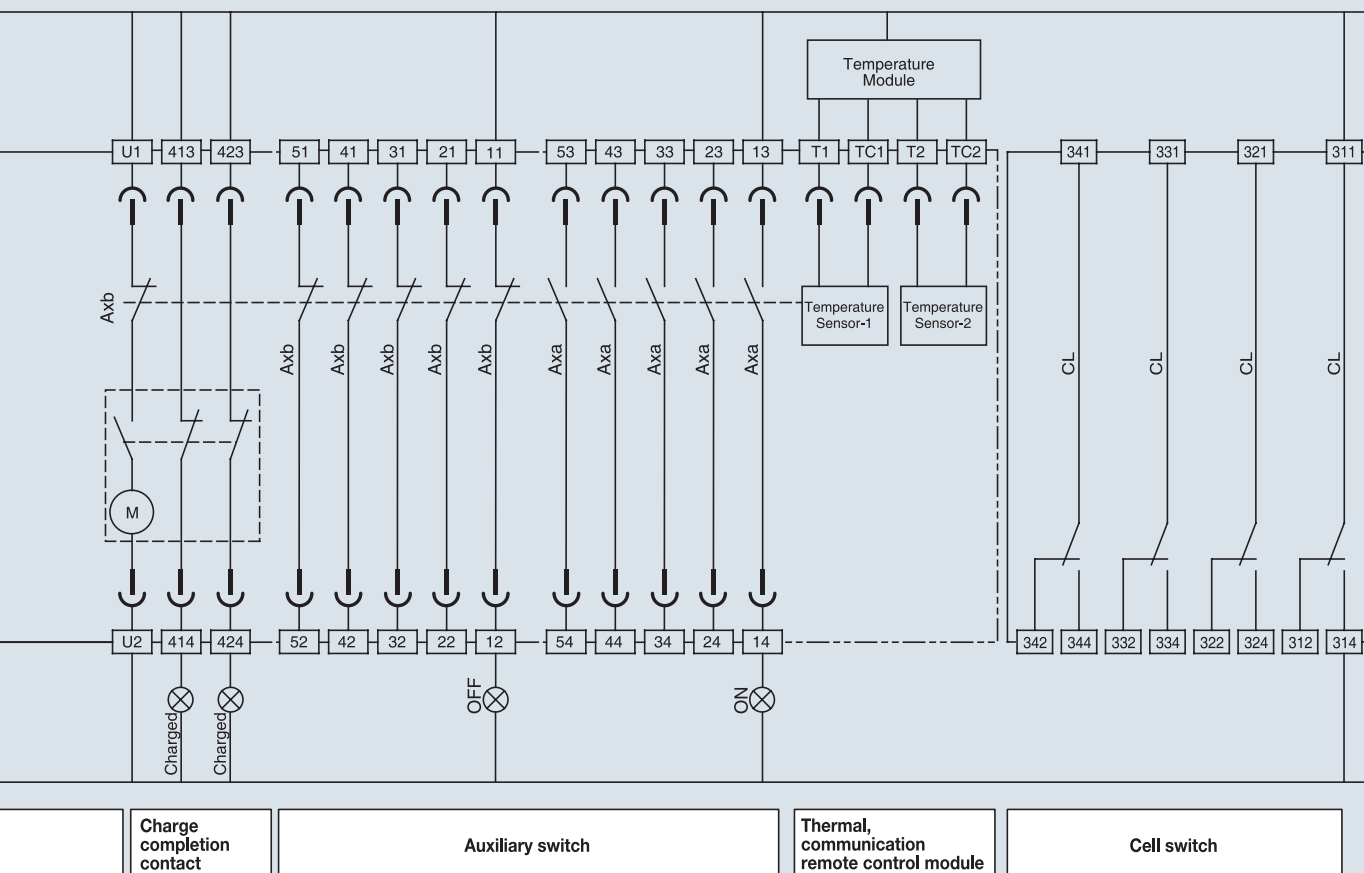

Accessory code description

Z1	Z2	ZSI input
Z3	Z4	ZSI output
E1	E2	ZCT
VN	V3	Voltage module
TC1, TC2	T1, T2	Temperature module
311	344	Position switch

Ax	Auxiliary switch
LTD	Long time delay trip indicator
STD/Inst	Short time delay/instantaneous
GTD	Ground fault trip indicator
CL	Cell switch
(M)	Motor
(CC)	Closing coil
(ST1)	Shunt tripping device 1
(ST2)	Shunt tripping device 2
(UVT)	UVT coil

—	Internal wiring
—	External wiring (by customer)
⌋	Connector of the control circuit terminal of drawout type

Susol ACB

Fixed type 2000AF (630~1600A: AH/AN/AS-06~16D) Dimensions

Dimensions: [mm]

Front view

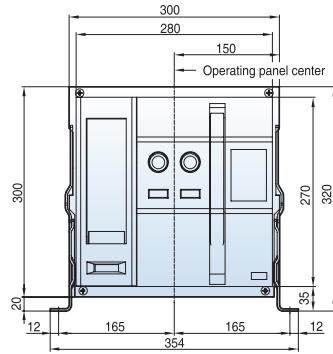

3P

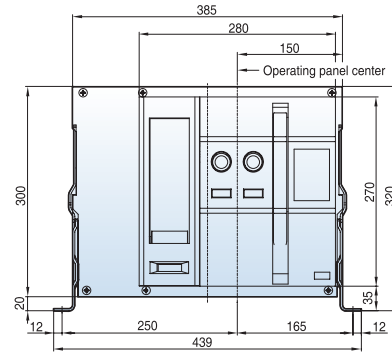

4P

Vertical type

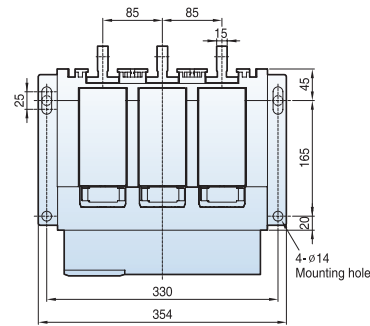

3P

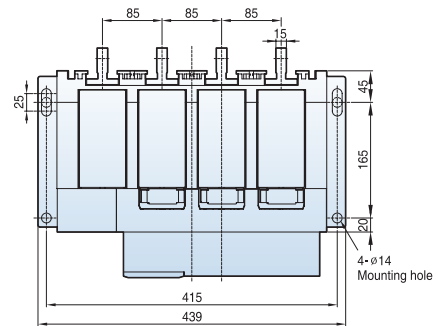

4P

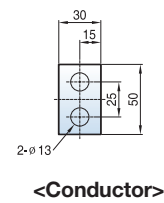
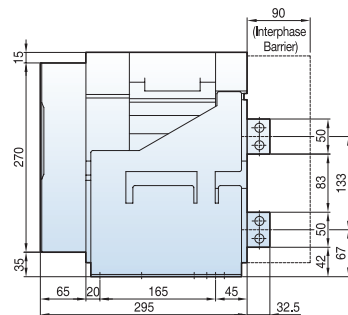

<Conductor>

Door Frame: DF (AH/AN/AS-D/E)

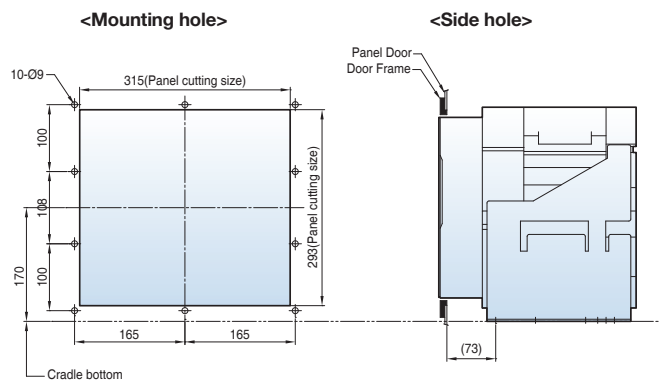

Note) The dimensions are for fixed type.

Horizontal type

Dimensions: [mm]

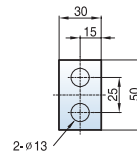
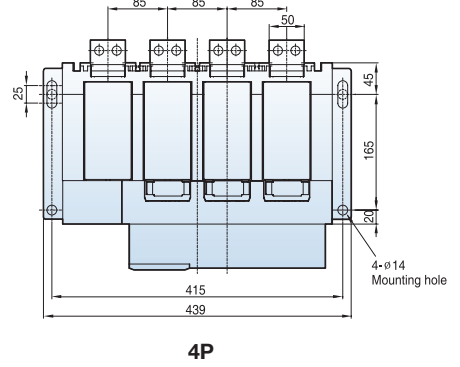
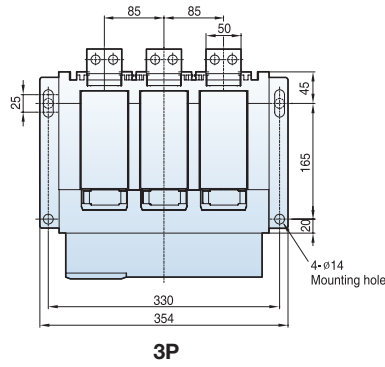

Front connection type

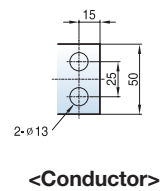
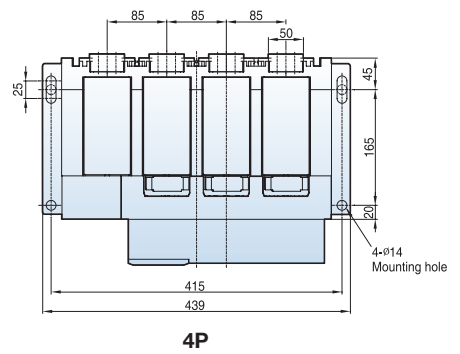
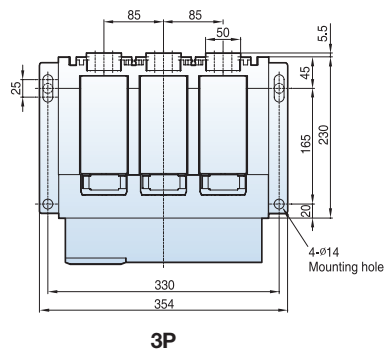

Susol ACB

Draw-out type 2000AF (630~1600A: AH/AN/AS-06~16D) Dimensions

Dimensions: [mm]

Front view

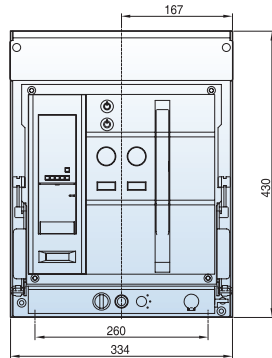

3P

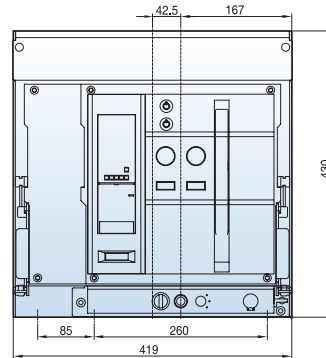

4P

Vertical type

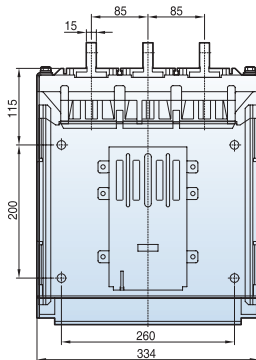

3P

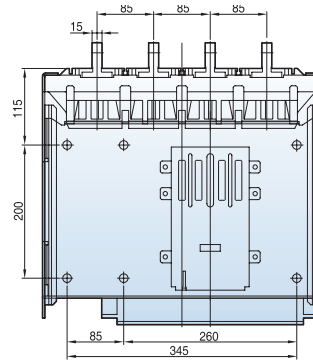

4P

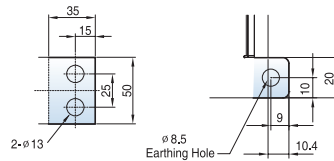
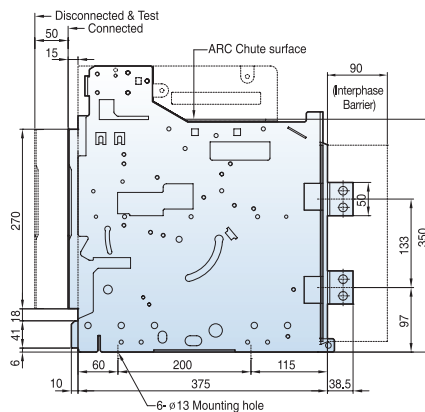

<Conductor>

Door Frame: DF (AH/AN/AS-D/E)

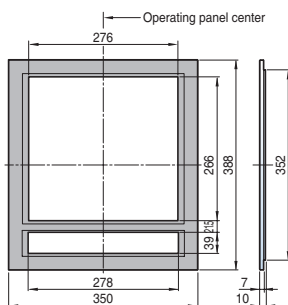

<External size>

<Mounting hole>

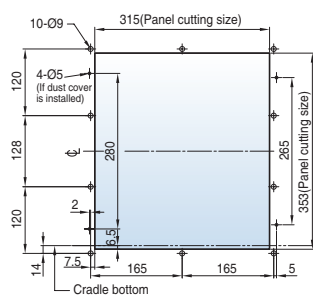

<Side hole>

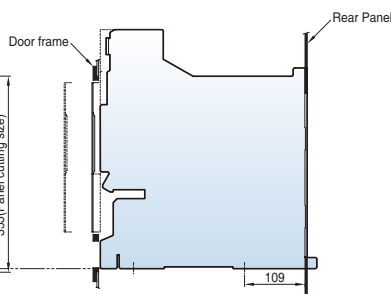

<Panel cutting >

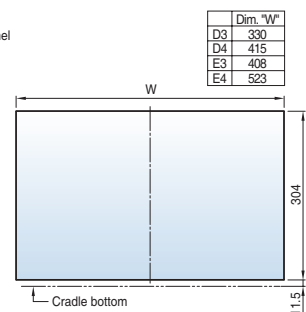

	Dim. "W"
D3	330
D4	415
E3	408
E4	523

Note) The dimensions are for drawout type.

Horizontal type

Dimensions: [mm]

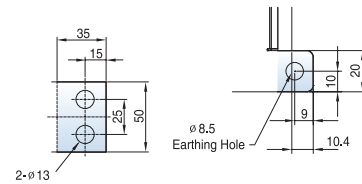
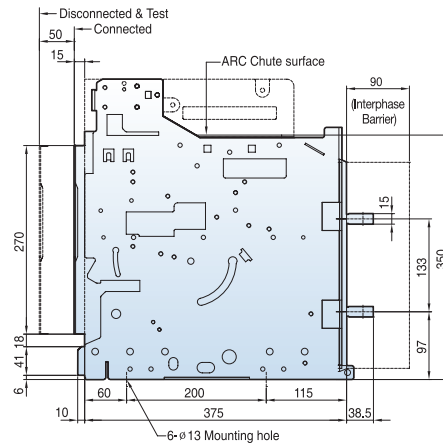
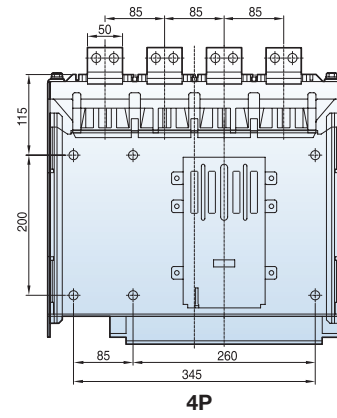
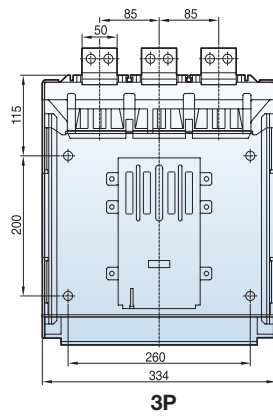



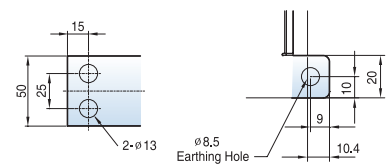
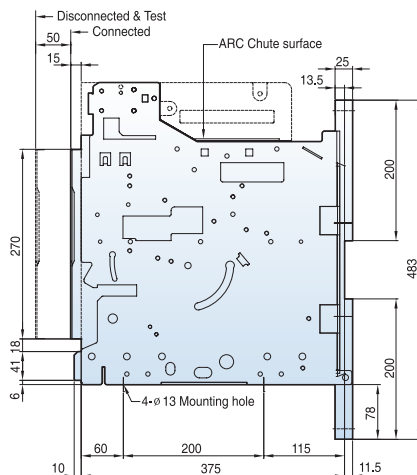
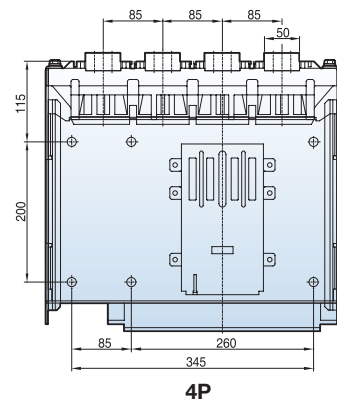
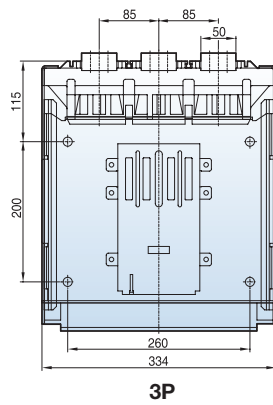

<Conductor>

Front connection type



Susol ACB (~6300AF) Trip relays

Trip relay types

Classification	N type	A type	P type	S type
Externals				
Current protection	• L / S / I / G / Thermal	• L / S / I / G(or EL) • Thermal • ZSI (Protective coordination)	• L / S / I / G(or EL) • Thermal (linear hot start) • ZSI (Protective coordination)	• L / S / I / G(or EL) • Thermal (linear hot start) • ZSI (Protective coordination)
Other protection	-	-	• Over/Under voltage • Over/Under frequency • Unbalance(Voltage/Current) • Reverse power	• Over/Under voltage • Over/Under frequency • Unbalance(Voltage/Current) • Reverse power
Measurement function	-	• Current (R / S / T / N)	• 3 Phase Voltage/Current RMS/Vector • Power(P, Q, S), PF(3-Phase) • Energy(Positive/Negative) • Frequency, Demand	• 3 Phase Voltage/Current RMS/Vector • Power(P, Q, S), PF(3-Phase) • Energy(Positive/Negative) • Frequency, Demand • Voltage/Current harmonics (1st~63th) • 3 Phase Waveforms • THD, TDD, K-Factor
Fine adjustment	-	-	• Fine adjustment for long/short time delay/instantaneous/ground	• Fine adjustment for long/short time delay/instantaneous/ground
Pre Trip Alarm	-	-	• Overload protection relays : DO (Alarm) (Ground fault is not available when using Pre trip alarm)	• Overload protection relays : DO (Alarm) (Ground fault is not available when using Pre trip alarm)
Digital Output	-	• 3DO (Fixed) • L, S/I, G Alarm	• 3DO (Programmable) • Trip, Alarm, General	• 3DO (Programmable) • Trip, Alarm, General
IDMTL setting	-	-	• Compliance with IEC60255-3 SIT, VIT, EIT, DT	• Compliance with IEC60255-3 SIT, VIT, EIT, DT
Communication	-	• Modbus/RS-485 • Profibus-DP	• Modbus/RS-485 • Profibus-DP	• Modbus/RS-485 • Profibus-DP
Power supply	• Self Power - Power source works over 20% of load current.	• Self Power 1) 1 ϕ : Power source works over 30% of load current 2) 3 ϕ : Power source works over 15% of load current - External power source are required for comm. • AC/DC 100~250V • DC 15~60V	• AC/DC 100~250V • DC 15~60V	• AC/DC 100~250V • DC 15~60V
RTC timer	-	• Available	• Available	• Available
LED for trip info.	• Long time delay • Short time delay/Instantaneous • Ground fault	• Long time delay • Short time delay/Instantaneous • Ground fault	• Long time delay • Short time delay/Instantaneous • Ground fault	• Long time delay • Short time delay/Instantaneous • Ground fault
Fault recording	-	• 10 records (Fault/Current/Date and Time)	• 256 records (Fault/Current/Date and Time)	• 256 records • Last fault wave form recording (Voltage, current are recorded in 3-phase, and can be read only by communication)
Event recording	-	-	• 256 records (Content, Status, Date)	• 256 records (Content, Status, Date)
Operating button	• Reset button	• Reset, Menu Up/Down, Tap, Enter	• Reset, Menu Up/Down, Tap, Enter	• Reset, Menu Up/Down, Tap, Enter

Basic protection function(L / S / I / G) is still under normal operation without control power.

Each OCR type has Battery in itself.
 1. Battery lifespan
 1) When turned off : 14~28years
 2) When using 1 LED consecutively or turned off : 7~14days
 2. The display minimum range of OCR current
 1) OCR-A type : When more 15% than rated current (In)
 2) OCR-P/S type : When more 12% than rated current (In)

* L/S/I/G(or EL)configuration as standard (Only. Unable to select ground fault and earth leakage, simultaneously)

Smart Trip Unit ordering

N type



N	
Trip unit type	
O	N/A

H	
Communication & Leakage detection	
O	N/A

G	
Control power & Frequency	
O	N/A

N	
Trip unit type	
N	Normal

H	
Relay Function / Commutation Function(Default)	
H	L,S,I,G + NFC

G		
Frequency (Main Circuit)	Control power voltage	
O	60Hz	No control power
5	50Hz	No control power

* NFC : Near Field Communication

* Self-power is Default
* No Output Contact
(Accident indication can be confirmed only by LED)

A type



A	
Trip unit type	
A	Ammeter

G	
Relay function / Commutation function	
H	L,S,I,G
D	L,S,I,G / Communication
J	L,S,I,Gext + ZCT / Communication
Y	L,S,I,Gext + Ground wire CT / Communication
B	L,S,I + PTA / Communication
O	L,S,I,G + Neutral CT / Communication
V	L,S,I + PTA (For Marine)

0		
Frequency (Main Circuit)	Control power voltage	
0	60Hz	No control power
1	60Hz	AC/DC 110V~220V
2	60Hz	DC 24V~48V TBD
5	50Hz	No control power
6	50Hz	AC/DC 110V~220V
7	50Hz	DC 24V~48V TBD

* Self-power is Default
* Only AH Type can select "0, 5"(AH0, AH5)
* No Output Contact when choosing "0"
(Accident indication can be confirmed only by LED)
* AV Type has no LCD Screen

P type



P	
Trip unit type	
P	Power meter

S	
Relay function / Commutation function(Default)	
S	L,S,I,G + PTA
J	L,S,I,Gext + ZCT
Y	L,S,I,Gext + Ground wire CT
O	L,S,I,G + Neutral CT

1			
Frequency (Main Circuit)	Control power voltage	Communication	
1	60Hz	AC/DC 110V~220V	N/A
2	60Hz	DC 24V~48V	N/A TBD
6	50Hz	AC/DC 110V~220V	N/A
7	50Hz	DC 24V~48V	N/A TBD
3	60Hz	AC/DC 110V~220V	Bluetooth
4	60Hz	DC 24V~48V	Bluetooth TBD
8	50Hz	AC/DC 110V~220V	Bluetooth
9	50Hz	DC 24V~48V	Bluetooth TBD

S type



S	
Trip unit type	
S	Supreme meter

S	
Relay function / Commutation function(Default)	
S	L,S,I,G + PTA
J	L,S,I,Gext + ZCT
Y	L,S,I,Gext + Ground wire CT
O	L,S,I,G + Neutral CT

1			
Frequency (Main Circuit)	Control power voltage	Communication	
1	60Hz	AC/DC 110V~220V	Bluetooth/NFC
2	60Hz	DC 24V~48V	Bluetooth/NFC TBD
6	50Hz	AC/DC 110V~220V	Bluetooth/NFC
7	50Hz	DC 24V~48V	Bluetooth/NFC TBD

- * Self-power is Default (Automatic power supply to the Trip Unit without additional control power)
- * L,S,I: Long time delay trip, Short time delay trip, Instantaneous trip
- * G: Ground fault (Residual earth fault protection)
- * Gext + ZCT: Earth leakage protection (Earth Fault Current: 0.5A ~ 30A) - Only suitable for under 1600A products and cables
- * Gext + Ground wire CT: Source return Type * PTA: Pre-trip alarm Function
- * Customers purchase their own Ground wire CT (Secondary output: 5A, accuracy 1%)
- * Customers purchase their own Neutral CT (Primary output: same as ACB's Rated Current / Secondary output: 5A, accuracy 1%)
- * The STU acceptable voltage range is 100 to 250V.
- * If you want an external VDM, please insert '(-V)' at the end of the full ordering.

Item	Description	Features	Remark
72313460708	TOTAL ASSY,VDM(Shield Cable), EXTERNAL, STU	Accessory	Separate purchasing

* If you want to apply external VDM separately, please order the code above.

Susol Compact ACB (1600A)



Fixed type

Draw-out type

Rating

Common characteristics								
Number of poles	(P)					3P / 4P		
Frequency	(Hz)					50/60Hz		
Rated operational voltage	(V, Ue)					690V		
Rated insulation voltage	(V, Ui)					1000V		
Rated impulse withstand voltage	(kV, Uimp)					12kV		
Circuit breaker as per IEC60947-2								
Type			AN/AH/AR-C					
Description			AN-08C	AN-16C	AH-08C	AH-16C	AR-08C	AR-10C
Ampere Frame	(AF)		800	1600	800	1600	800	1000
Rated current (In Max.) at 40°C	(A)		400	-	400	-	400	-
	(A)		630	-	630	-	630	-
	(A)		800	800	800	800	800	800
	(A)		-	1000	-	1000	-	1000
	(A)		-	1250	-	1250	-	-
	(A)		-	1600	-	1600	-	-
Rated current of neutral pole	(A)		100%					
Rated breaking capacity (Icu)	(kA)	IEC60947-2	AC 690V/600V/550V	42	50		-	
			AC 500V/480V/460V	42	50		130 ¹⁾	
			AC 415V/380V/220V	50	60		150	
Rated service breaking capacity (Ics)	(kA, %×Icu)		100%					
Rated making capacity (Icm)	(kA)		88.2		105		17 ²⁾	
Rated Short-time capacity (Icw)	(kA)		1sec/3sec	42/25	50/30		10 ³⁾	
Operating time (t)	(ms)		Total breaking time		40			
			Closing time		80			
Common mechanical and electrical life cycle								
Life cycle	(time)		Mechanical		12,500		5,000	
			Electrical		6,000		3,000	
Common dimension and weight								
Weight	(kg)		Draw-out type (3P/4P)		16/19.5			
			Fixed type (3P/4P)		16/19.5			
			Cradle (3P/4P)		22/26			
Dimension	(mm)	Draw-out type	3P	W: 256 D: 269.5 ⁴⁾ H: 364.3				
			4P	W: 326 D: 269.5 ⁴⁾ H: 364.3				
		Fixed type	3P	W: 272.4 D: 198.5 ⁴⁾ H: 322				
			4P	W: 342.4 D: 198.5 ⁴⁾ H: 322				

1) 130kA/460V, 100kA/500V 2) at 500V 3) 0.5sec 4) Exclude terminal length

Susol Compact ACB (up to 800Vac)



Fixed type



Draw-out type

Rating

Characteristics			
Number of poles	(P)		3 / 4
Rated operational voltage (Ue)	(Vac)		~ 800
Rated insulation voltage (Ui)	(V)		1000
Rated impulse withstand voltage (Uimp)	(kV)		12kV
Version			Fixed / Withdrawable
Suitability for isolation			
Degree of pollution	IEC60661-1		3
Certification			CB certification according to IEC 60947-2
Brand name		Susol AW	
Model		AW-08C	AW-16C
Ampere Frame	(AF)	800	1600
Rated current (In max)	(A)	400 630 800	800 1000 1250 1600
Rated ultimate breaking capacity (Icu)	800V (kA)		40
Rated service breaking capacity (Ics)	(% Icu)		100
Rated short-time withstand current (Icw)	1s (kA)		40
	3s (kA)		40
Rated making capacity (Icm)	(%)		84
Selectivity category (according to IEC 60947-2)			B
Operation time (ms)	Total Breaking time < Icw		max. 75
	≥ Icw		max. 25
	Closing time		max. 80
Mechanical and Electrical Life cycle			
Endurance (times) (Without maintenance)	Mechanical		12,500
	Electrical		500
Dimension and Weight			
Weight	Draw-out (3P/4P)	(kg)	22/26
	Fixed (3P/4P)	(kg)	16/19.5
External Dimensions (H×W×D)	Draw-out	3P (mm)	W: 256 D: 274.5 ¹⁾ H: 364.3
		4P (mm)	W: 326 D: 274.5 ¹⁾ H: 364.3
	Fixed	3P (mm)	W: 272.4 D: 198.5 ¹⁾ H: 322
		4P (mm)	W: 342.4 D: 198.5 ¹⁾ H: 322

¹⁾ Exclude terminal length

* AW-08/16C are applicable for IT system

Susol Compact ACB dimensions

• 3P [Fixed H: Horizontal type / V: Vertical type]

(Unit : mm)

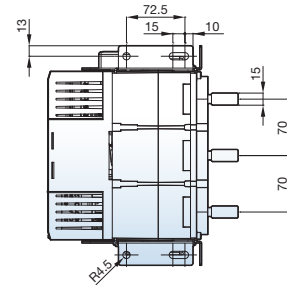
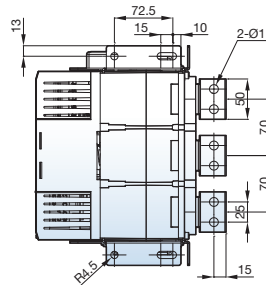
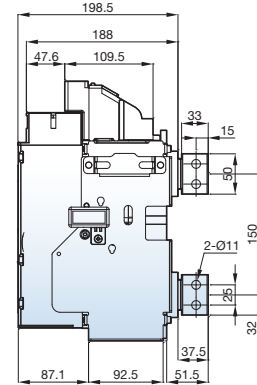
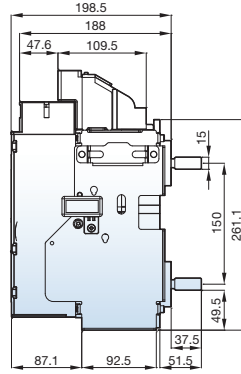
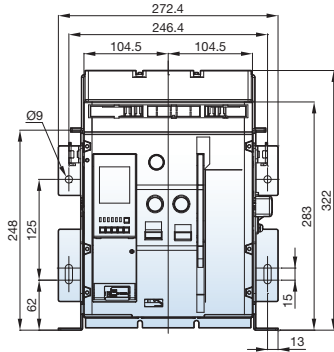

H Type (Horizontal type)

V Type (Vertical type)

• 3P [Fixed M: Upper-Horizontal type, Lower-Vertical type / N: Upper-Vertical type, Lower-Horizontal type]

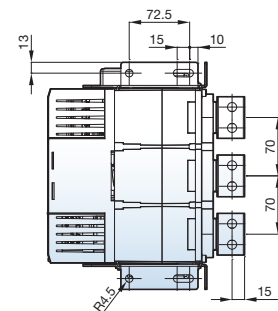
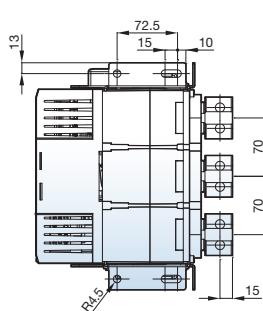
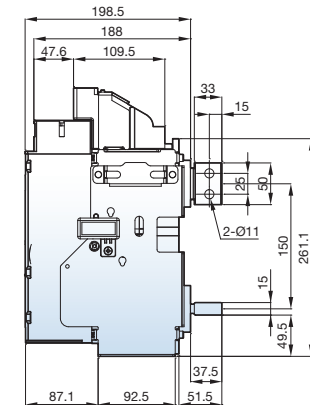
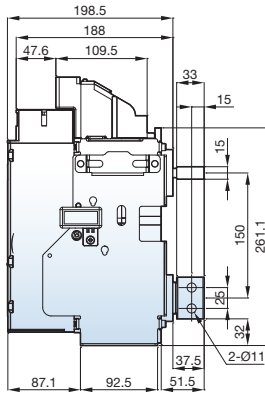
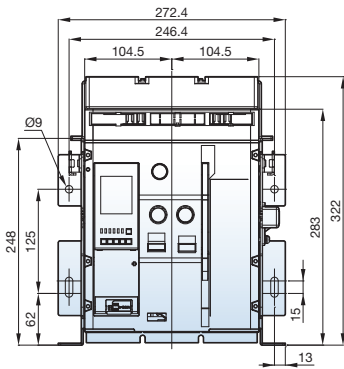

M Type

(Upper-Horizontal type, Lower-Vertical type)

N Type

(Upper-Vertical type, Lower-Horizontal type)

• 3P [Fixed P: Plane type / R: Spread type]

(Unit : mm)

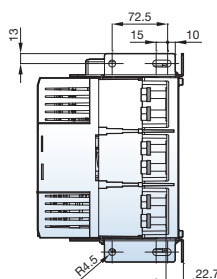
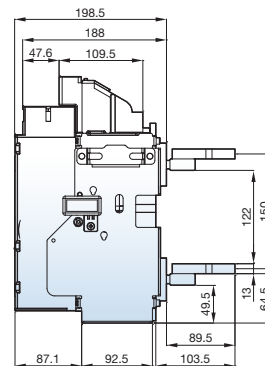
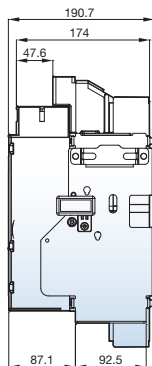
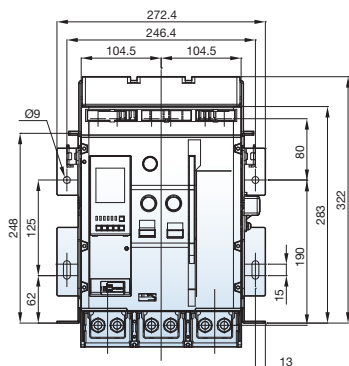

P Type (Plane type)

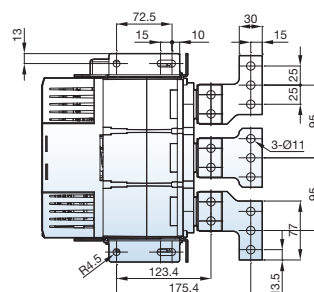

R Type (Spread type)

• 3P [Fixed Z: Plane spread type / T: Plane vertical type]

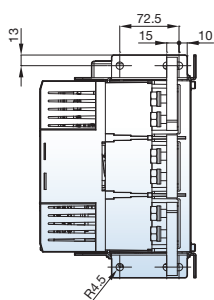
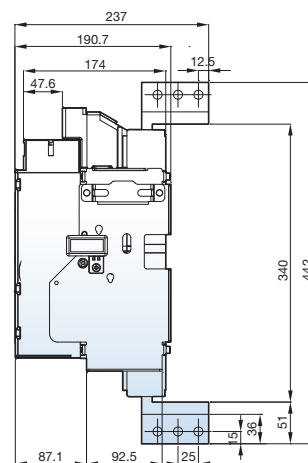
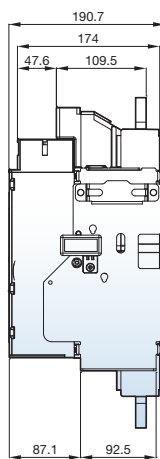
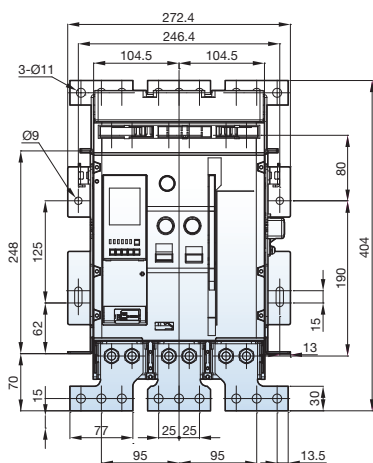

Z Type (Plane spread type)

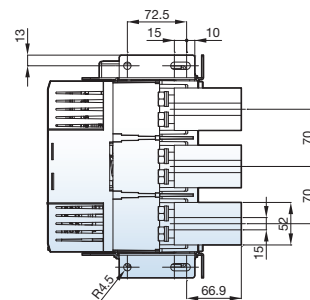

T Type (Plane vertical type)

Susol Compact ACB dimensions

• 3P [Draw-out H: Horizontal type / V: Vertical type]

(Unit : mm)

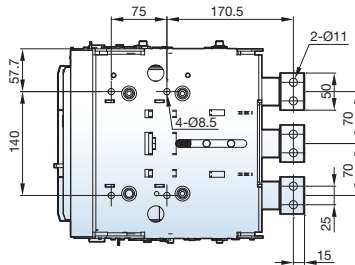
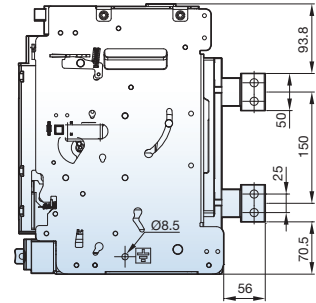
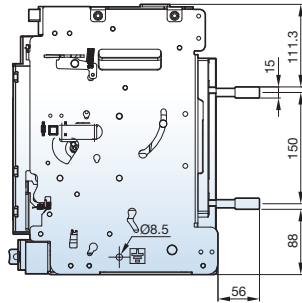
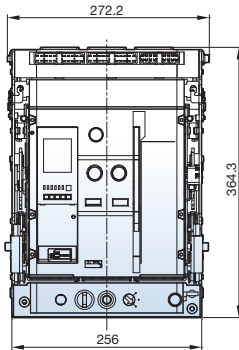

H Type (Horizontal type)

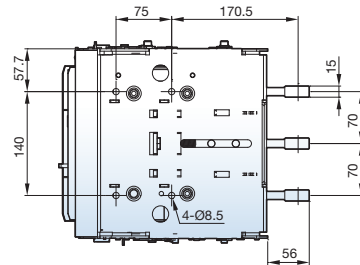

V Type (Vertical type)

• 3P [Draw-out M: Upper-Horizontal type, Lower-Vertical type / N: Upper-Vertical type, Lower-Horizontal type]

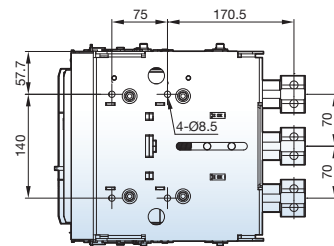
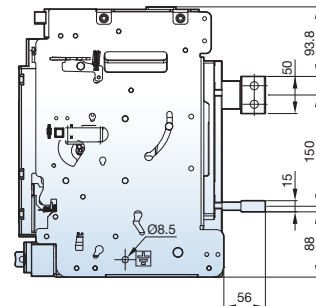
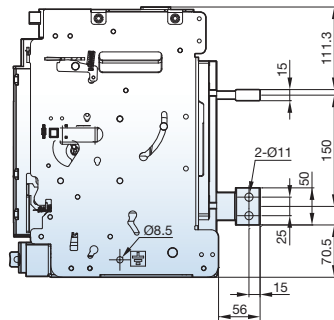
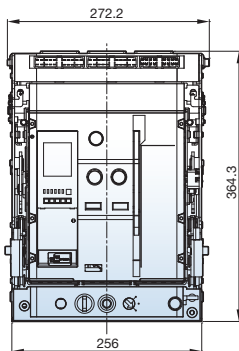

M Type

(Upper-Horizontal type, Lower-Vertical type)

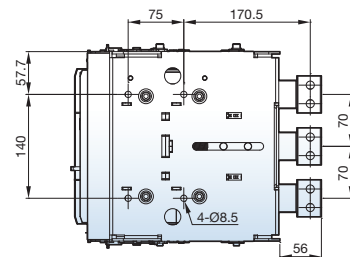

N Type

(Upper-Vertical type, Lower-Horizontal type)

• 3P [Draw-out P: Plane type / R: Spread type]

(Unit : mm)

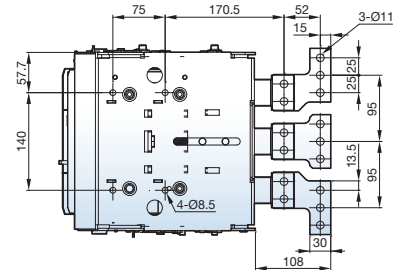
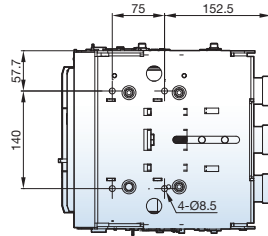
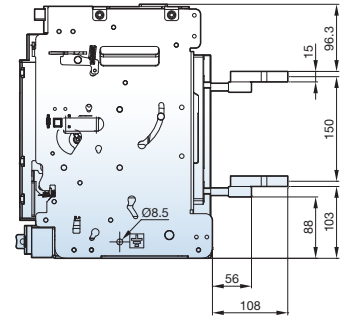
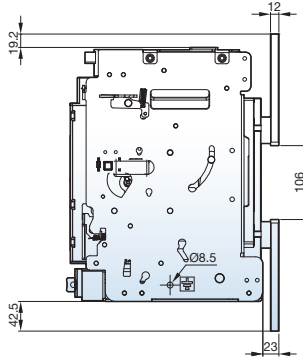
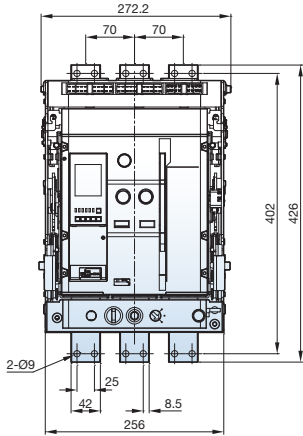

P Type (Plane type)

R Type (Spread type)

• 3P [Draw-out Z: Plane spread type / T: Plane vertical type]

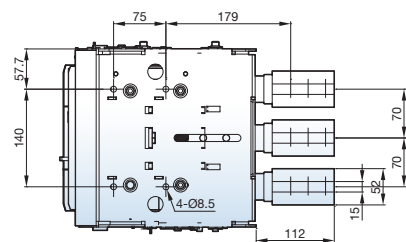
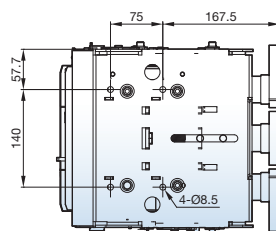
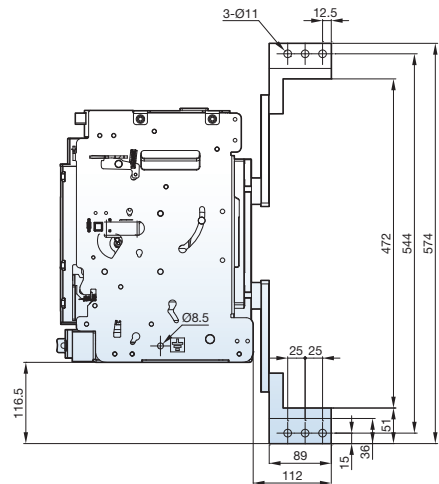
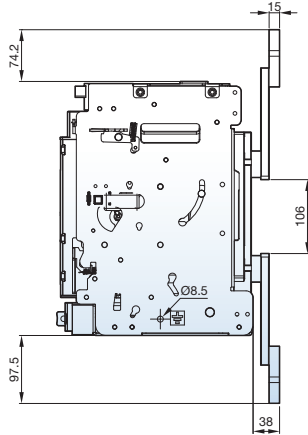
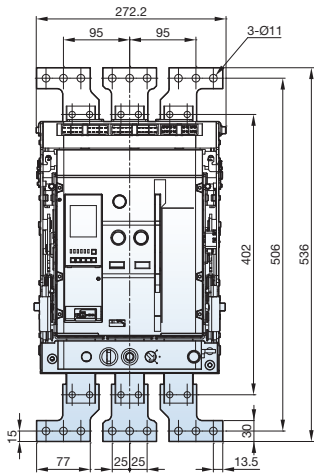

Z Type (Plane spread type)

T Type (Plane vertical type)

Susol Compact ACB diagram

Electrical diagram

This diagram is based on "CONNECTED" position of a circuit breaker and Opening, Motor charging, Releasing of locking plate should be normal condition.

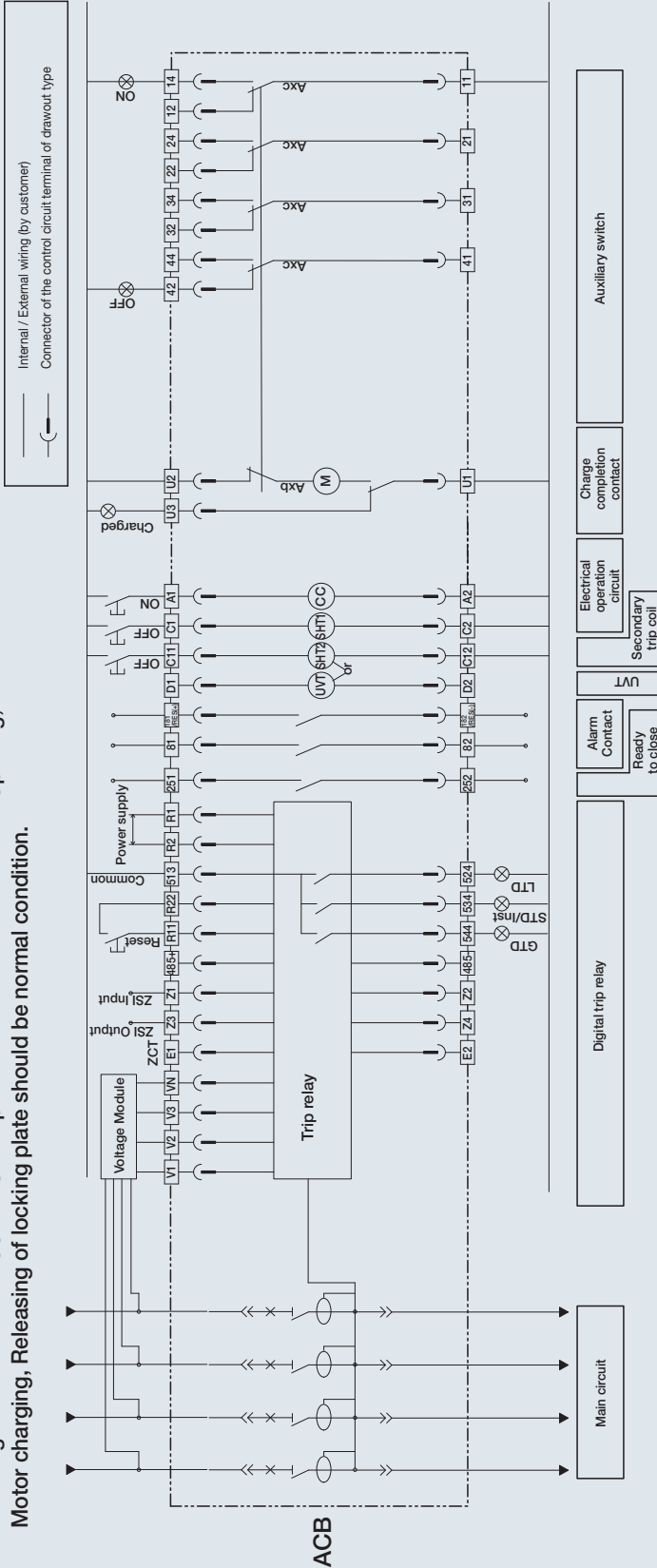

Terminal code description

11	12	~	41	42	Auxiliary switch "b" contact
11	14	~	41	44	Auxiliary switch "a" contact
U1	U3				Charge completion signal
U1	U2				Motor charging
A1	A2				Closing coil
C1	C2				Shunt trip
C11	C12				2nd shunt trip

Accessory code description

Axc	Auxiliary switch
LTD	Long time delay trip indicator
STD/Inst	Short time delay/instantaneous
GTD	Ground fault trip indicator
CL1-CL4	Cell switch
(M)	Motor
(CC)	Closing coil
(SHT)	1st Shunt coil
(SHT)	2nd Shunt coil
(UVT)	UVT coil





Terminal code description

D1	D2	Voltage input terminal of UVT coil	
81	82	Alarm1 "a" contact	
181	182	Alarm2 "a" contact or RES Coil	
251	252	Ready to close switch	
R1	R2	Control power for trip unit	
513	~	544	Fault cause indication contacts
R11	R22	Alarm reset (Trip cause LEDs, contacts)	

- Note) 1. The diagram is shown with circuit de-energized, all devices open and charged and relays in normal position
 2. Relay is normal condition and charging type is "Off-Charging"
 3. The standard of auxiliary contact is 4C.
 4. Option
 - Ready to close contact, Trip alarm contact, UVT coil, Fully charged contact, secondary trip coil
 - Temperature module, Voltage module, ZCT, ZSI
 5. Please consult us for the use of ZSI (Zone selective Interlocking)
 6. For connecting RS-485 verify if the polarity is correct
 7. Contact configuration for Cell Switch can be changeable if necessary

Susol Compact ACB 1600A Trip relays

Trip relay types

Classification	N type	A type	P type	S type
Externals				
Current protection	<ul style="list-style-type: none"> L/S/I/G/Thermal 	<ul style="list-style-type: none"> L/S/I/G/Thermal ZSI (Protective coordination) 	<ul style="list-style-type: none"> L/S/I/G ZSI (Protective coordination) Thermal (Linear Hot Start) 	<ul style="list-style-type: none"> L/S/I/G ZSI (Protective coordination) Thermal (Linear Hot Start)
Other protection	-	<ul style="list-style-type: none"> Earth leakage (Option) 	<ul style="list-style-type: none"> Earth leakage (Option) Over/Under voltage Over/Under frequency Unbalance (Voltage/Current) Reverse power 	<ul style="list-style-type: none"> Earth leakage (Option) Over/Under voltage Over/Under frequency Unbalance (Voltage/Current) Reverse power
Measurement function	-	<ul style="list-style-type: none"> Current (R/S/T/N) 	<ul style="list-style-type: none"> 3 Phase Voltage/Current RMS/Vector Power (P, Q, S), PF (3-Phase) Energy (Positive/Negative) Frequency, Demand 	<ul style="list-style-type: none"> 3 Phase Voltage/Current RMS/Vector Power (P, Q, S), PF (3-Phase) Energy (Positive/Negative) Frequency, Demand Voltage/Current harmonics (1st~63th) 3 Phase Waveforms THD, TDD, K-Factor
Fine adjustment	-	-	<ul style="list-style-type: none"> Fine adjustment for long/short time delay/instantaneous/ ground 	<ul style="list-style-type: none"> Fine adjustment for long/short time delay/instantaneous/ ground
Digital Output	-	<ul style="list-style-type: none"> 3DO (Fixed) L, S/I, G Alarm 	<ul style="list-style-type: none"> 3DO (Programmable) Trip, Alarm, General 	<ul style="list-style-type: none"> 3DO (Programmable) Trip, Alarm, General
IDMTL setting	-	-	<ul style="list-style-type: none"> Compliance with IEC60255-3: SIT, VIT, EIT, DT 	<ul style="list-style-type: none"> Compliance with IEC60255-3: SIT, VIT, EIT, DT
Communication	-	<ul style="list-style-type: none"> Modbus/RS-485 Profibus-DP 	<ul style="list-style-type: none"> Modbus/RS-485 Profibus-DP 	<ul style="list-style-type: none"> Modbus/RS-485 Profibus-DP
Power supply	<ul style="list-style-type: none"> Self Power Power source worksover 20% of load current. 	<ul style="list-style-type: none"> Self Power Power source worksover 20% of load current. External power source are required for comm. AC/DC 100~250V DC 24~60V 	<ul style="list-style-type: none"> AC/DC 100~250V DC 24~60V Basic protection function (L/S/I/G) is still under normal operation without control power. 	<ul style="list-style-type: none"> AC/DC 100~250V DC 24~60V Basic protection function (L/S/I/G) is still under normal operation without control power.
RTC Timer	<ul style="list-style-type: none"> Available 	<ul style="list-style-type: none"> Available 	<ul style="list-style-type: none"> Available 	<ul style="list-style-type: none"> Available
LED for trip info.	<ul style="list-style-type: none"> Long time delay Short time delay/Instantaneous Ground fault 	<ul style="list-style-type: none"> Long time delay Short time delay/Instantaneous Ground fault 	<ul style="list-style-type: none"> Long time delay Short time delay/Instantaneous Ground fault 	<ul style="list-style-type: none"> Long time delay Short time delay/Instantaneous Ground fault
Fault recording	-	<ul style="list-style-type: none"> 10 records (Fault/Current/Date and Time) 	<ul style="list-style-type: none"> 256 records 	<ul style="list-style-type: none"> 256 records Last fault wave form recording (3 Phase)
Event recording	-	-	<ul style="list-style-type: none"> 256 records (Content, Status, Date) 	<ul style="list-style-type: none"> 256 records (Content, Status, Date)
Operating button	<ul style="list-style-type: none"> Reset button 	<ul style="list-style-type: none"> Reset, Menu Up/Down, Left/Right, Enter 	<ul style="list-style-type: none"> Reset, Menu Up/Down, Left/Right, Enter 	<ul style="list-style-type: none"> Reset, Menu Up/Down, Left/Right, Enter

Each OCR type has Battery in itself.

1. Battery lifespan

1) When turned off: 14~28years

2) When using 1 LED consecutively or turned off: 7~14days

2. The recognizable range of OCR current

1) 10: When more 20% than rated current(I_n) (ratio to I_n regardless of I_u and I_r)

2) 30: When more 12% than rated current(I_n)

Memo

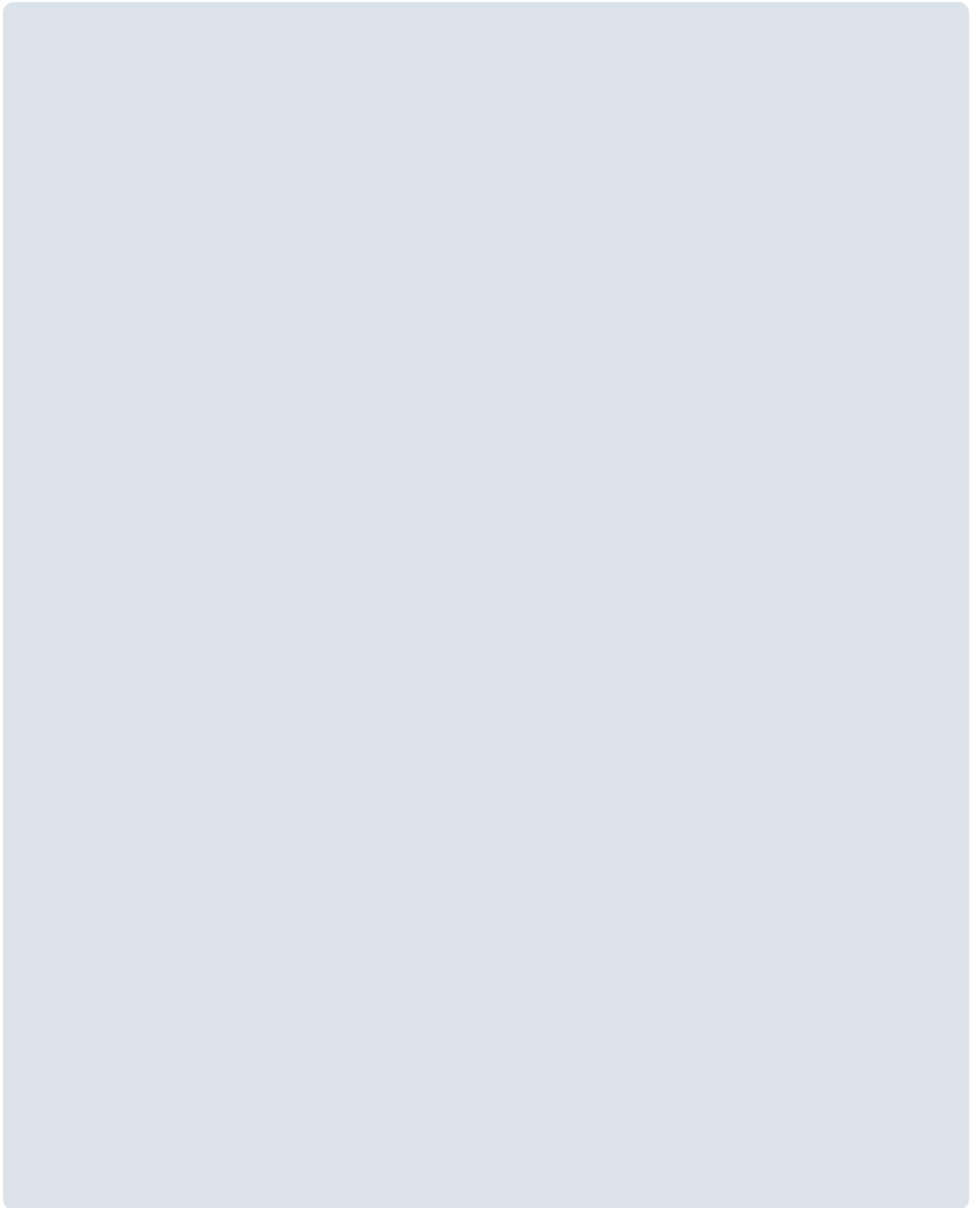

VCB

Vacuum Circuit Breakers

Vacuum Circuit Breaker, VCB is installed in the medium voltage distribution lines to protect life and load equipment. In case of accidents such as over current, short circuit and ground fault current, VCB works by interrupting the circuit through the inner Vacuum Interrupter which is acted by signal from the outside separate relay.

Suitable for use as the main circuit breaker to protect key installations in the places such as device industry, power plants, high-rise buildings, large ships.

- ▶ **Strengthening of the high interrupting capacity and large current models and full line-up new VCB models to high/middle/low.**
- ▶ **Main circuit structure with high reliability.**
 - Maximizing the durability and reliability of the main circuit contactors (Stego Tulip contactor).
 - Strong structure for the temperature rise (Natural cooling system).
- ▶ **Convenience of switchgear configuration and a variety of accessories.**
 - CB compartment structure: Metal isolation structures to prevent the accident spread and ensure safety. And the convenience of switchgear building is extended by its module style.
 - A variety of accessories: UVT, Locking Magnet, Plug Interlock, Key lock, Temperature Sensor, MOC, TOC, Earthing S/W.
 - Maximizing compatibility with existing products through the dualistic deployment of phases and compact models.

※ Type testing is complete for all models according to latest standard, IEC62271-100 (2012) [M2, E2 (List1 or 3), C2].





7.2kV (VL-06)

- Rated short-time (for withstand current) : 3sec.
- Rated operating sequence: O-0.3s-CO-15s-CO
- Type test level: M2, E2 (List1), C2
- 100% Compatibility
 - with existing fixed type breakers
 - with existing drawout type breakers
- Various cradle: E, F and G type
- A variety of control power
 - DC 24~30V, DC 48~60V, DC 110V, DC 125V, DC 220V
 - AC 48V, AC 100~130V, AC 220~250V
- A variety of accessories
 - Charge switch, UVT, Secondary trip Coil, Current trip coil, Trip Latch Checking S/W, Position S/W
 - Key-lock, Button lock, Button cover, Padlock, UVT, Time Delay Controller, Lifting hook, CTD
- Anti Pumping Device
- TEST/SERVICE Automatic Position Indicator
- Standards and certification
 - IEC62271-100 (2012) [M2, C2, E2 (List1)]
 - Tested in enclosure
 - KERI type tested, V-check (KESCO) certification

Susol VCB Family

Susol VCB series are premium-type products featuring main structure with high reliability application and a variety of accessories and ability to maximize to be suitable for use as the main circuit breaker to protect key installations in the places such as device industry, power plants, high-rise buildings, large ships



Ur (kV)	Isc (kA)	Ir (A)
7.2	8	400
	12.5	630



Full line-up & Compact

Full line-up new VCB models to the high interrupting capacity and large current (~ 50kA, ~ 5000A) featuring maximization of compatibility with existing products through the dualistic deployment of phases and compact models

7.2/12/17.5/24/25.8/36kV (VL-06/12/17/20/25/36)

7.2/12/17.5/24/25.8/36kV (VH-06/12/17/20/25/36)

- Rated short-time (to withstand current): 3sec. 4sec*
- Rated operating sequence: O-0.3s-CO-15s-CO, (O-0.3s-CO-3min-CO**)
- Type test level: M2, E2 (List3), C2
- Compatibility with existing Pro-MEC breakers
- Various cradle: E, F, G and H type
- CB Compartment for MCSG available
- A variety of control power
 - DC 24~30V, DC 48~60V, DC 110V, DC 125V, DC 220V
 - AC 48V, AC 100~130V, AC 220~250V
- A variety of accessories
 - VCB part: Charge switch, UVT, Secondary trip coil, Latch checking switch, Position switch, Locking magnet, Plug interlock, Key lock, Button cover, Button padlock, Padlock (H type Door interlock), MOC
 - Cradle part: MOC (Mechanical Operated Cell switch), TOC (Truck Operated Cell switch), Temperature sensor, Earthing switch & accessories, Door, Door interlock, Door emergency button
 - Others: Racking in/out handle, UVT Time delay controller, CTD (Condensor Trip Device), Temperature module
- Anti Pumping Device
- TEST/SERVICE Automatic Position Indicator
- Standards and certification
 - IEC62271-100 (2012) [M2, C2, E2 (List3)]
 - KEMA, KERI type tested, V-check (KESCO) certification

- Rated short-time (to withstand current): 3sec. 4sec*
- Rated operating sequence: O-0.3s-CO-3min-CO
- Type test level: M2, E2 (List3), C2
- Electrical and mechanical life: 20,000 operations
- Various cradle: K and H type
- CB Compartment for MCSG available
- A variety of control power
 - DC 48V, DC 110V, DC 125V, DC 220V
 - AC 48V, AC 110V, AC 220V
- A variety of accessories
 - VCB part: UVT, Secondary trip coil, Latch checking switch, Position switch, Locking magnet, Plug interlock, Key lock, Button cover, Button padlock, Padlock (H type Door interlock), MOC
 - Cradle part: MOC (Mechanical Operated Cell switch), TOC (Truck Operated Cell switch), Temperature sensor, Earthing switch & accessories, Door, Door interlock, Door emergency button
 - Others: Racking in/out handle, Lifting hook, UVT Time delay controller, CTD (Condensor Trip Device), Temperature module
- Anti Pumping Device
- Standards and certification
 - IEC62271-100 (2012) [M2, C2, E2 (List3)]
 - KEMA, KERI type tested, V-check (KESCO) certification

Note) * Please contact us
 ** Please refer to the ratings.

Note) * Please contact us



Ur (kV)	Isc (kA)	Ir (A)
7.2	20	630
		1250
	25	630
		1250
	31.5	630
		1250
12	20	630
		1000
	25	630
		1000
	31.5	630
		1000
17.5	20	630
		1250
	25	630
		1250
	31.5	630
		1250
24, 25.8	12.5	630
		1250
	16	630
		1250
	25	630
		1250
36	25	630
		1250
	25	630
		1250
	31.5	630
		1250



Ur (kV)	Isc (kA)	Ir (A)
7.2	31.5	1250
		2000
	40	1250
		2000
	50	1250
		2000
12	31.5	1250
		2000
	40	1250
		2000
	50	1250
		2000
17.5	31.5	1250
		2000
	40	1250
		2000
	50	1250
		2000
24, 25.8	25	2500
		3150
	31.5	1250
		2000
	40	1250
		2000
36	25	1250
		2000
	31.5	1250
		2000
	40	1250
		2000

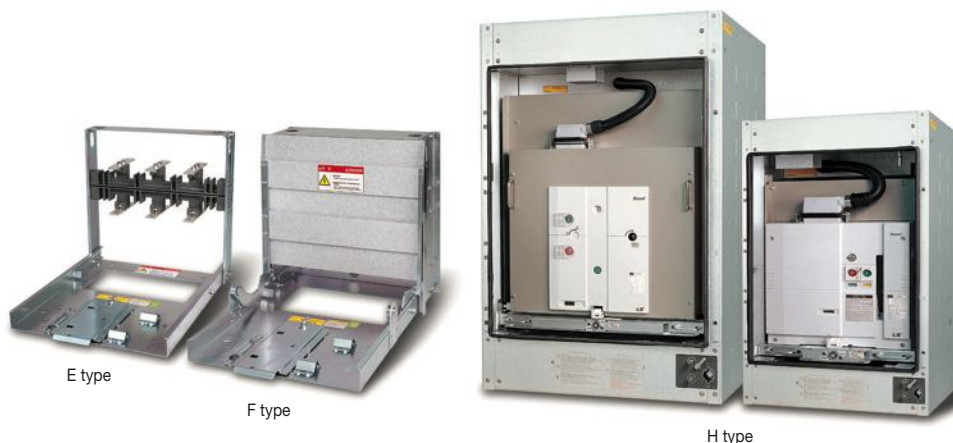

VCB Cradle type

Susol VCB

7.2/12/17.5/24/25.8/36kV (VL-06/12/17/20/25/36)

Ur [kV]	Isc [kA]	Ir[A]					VCB		CRADLE		Connector
		p=130	p=150	p=210	p=265	p=275	Type	Version	Type	Version	
7.2	8	400					VL-06□08A04	P,E,F,G	VCL-06□08A04	E,F,G	A
							VL-06□08B04	P,E,F,G	VCL-06□08B04	E,F,G	A
							VL-06□13A06	P,E,F,G	VCL-06□13A06	E,F,G	A
	12.5	630					VL-06□13B06	P,E,F,G	VCL-06□13B06	E,F,G	A
							VL-06□20A(K)06	P,E,F,G,H	VCL-06□20A(K)06	E,F,G,K,H	P,E,F,G,K:A/B, H:B
							VL-06□20A(K)13	P,E,F,G,H	VCL-06□20A(K)13	E,F,G,K,H	P,E,F,G,K:A/B, H:B
	20		630				VL-06□20A20	P,E,F,G,H	VCL-06□20A20	E,F,G,H	P,E,F,G:A/B, H:B
			1250				VL-06□25A(K)06	P,E,F,G,K,H	VCL-06□25A06	E,F,G,K,H	P,E,F,G,K:A/B, H:B
			2000				VL-06□25A(K)13	P,E,F,G,K,H	VCL-06□25A13	E,F,G,K,H	P,E,F,G,K:A/B, H:B
	25		630				VL-06□25A(K)20	P,E,F,G,K,H	VCL-06□25A20	E,F,G,K,H	P,E,F,G,K:A/B, H:B
			1250				VL-06□32A06	P,H	VCL-06H32A06	H	B
			2000				VL-06□32A(K)13	P,E,F,Fs,G,Gs,K,H	VCL-06□32A13	E,F,Fs,G,Gs,K,H	P,E,F,Fs,G,Gs,K:A/B,H:B
31.5		630				VL-06□32A(K)20	P,E,F,Fs,G,Gs,K,H	VCL-06□32A20	E,F,Fs,G,Gs,K,H	P,E,F,Fs,G,Gs,K:A/B,H:B	
		1250				VL-12□20A(K)06	P,K,H	VCL-12□20A06	K,H	K:A/B, H:B	
		2000				VL-12□20A(K)13	P,K,H	VCL-12□20A13	K,H	K:A/B, H:B	
12	20					VL-12H20A20	H	VCL-12H20A20	H	B	
				630			VL-12□20B06	P,E,F,H	VCL-12□20B06	E,F,H	P,E,F:A/B, H:B
				1250			VL-12□20B13	P,E,F,H	VCL-12□20B13	E,F,H	P,E,F:A/B, H:B
				2000			VL-12□20B20	P,E,F,H	VCL-12□20B20	E,F,H	P,E,F:A/B, H:B
				630			VL-12□20F06	E,F	VCL-12□20F06	E,F	A/B
				1250			VL-12□20F13	E,F	VCL-12□20F13	E,F	A/B
	25						VL-12□25A(K)06	P,K,H	VCL-12□25A06	K,H	K:A/B, H:B
							VL-12□25A(K)13	P,K,H	VCL-12□25A13	K,H	K:A/B, H:B
							VL-12□25A(K)20	K,H	VCL-12□25A20	K,H	K:A/B, H:B
				630			VL-12□25B06	P,E,F,H	VCL-12□25B06	E,F,H	P,E,F:A/B, H:B
				1250			VL-12□25B13	P,E,F,H	VCL-12□25B13	E,F,H	P,E,F:A/B, H:B
				2000			VL-12□25B20	P,E,F,H	VCL-12□25B20	E,F,H	P,E,F:A/B, H:B
	31.5						VL-12□25F06	E,F	VCL-12□25F06	E,F	A/B
							VL-12□25F13	E,F	VCL-12□25F13	E,F	A/B
				630			VL-12□32A06	P,H	VCL-12H32A06	H	B
				1250			VL-12□32A(K)13	P,Gs,K,H	VCL-12□32A13	Gs,K,H	Gs,K:A/B, H:B
				2000			VL-12□32A(K)20	Gs,K,H	VCL-12□32A20	Gs,K,H	Gs,K:A/B, H:B
				630			VL-12□32B06	P,H	VCL-12H32B06	H	B
17.5	20					VL-12□32B13	P,H	VCL-12H32B13	H	B	
						VL-12□32B20	P,H	VCL-12H32B20	H	B	
						VL-12□32B25	P,H	VCL-12H32B25	H	B	
					2500		VL-12□32D25	P,H	VCL-12H32D25	H	B
				630			VL-17H20A06	H	VCL-17H20A06	H	B
				1250			VL-17H20A13	H	VCL-17H20A13	H	B
	25						VL-17H20A20	H	VCL-17H20A20	H	B
				630			VL-17□20B06	P,E,F,H	VCL-17□20B06	E,F,H	P,E,F:A/B, H:B
				1250			VL-17□20B13	P,E,F,H	VCL-17□20B13	E,F,H	P,E,F:A/B, H:B
				2000			VL-17□20B20	P,E,F,H	VCL-17□20B20	E,F,H	P,E,F:A/B, H:B
				630			VL-17□20F06	E,F	VCL-17□20F06	E,F	A/B
				1250			VL-17□20F13	E,F	VCL-17□20F13	E,F	A/B
31.5						VL-17H25A06	H	VCL-17H25A06	H	B	
						VL-17H25A13	H	VCL-17H25A13	H	B	
						VL-17H25A20	H	VCL-17H25A20	H	B	
			630			VL-17□25B06	P,E,F,H	VCL-17□25B06	E,F,H	P,E,F:A/B, H:B	
			1250			VL-17□25B13	P,E,F,H	VCL-17□25B13	E,F,H	P,E,F:A/B, H:B	
			2000			VL-17□25B20	P,E,F,H	VCL-17□25B20	E,F,H	P,E,F:A/B, H:B	
31.5						VL-17□25F06	E,F	VCL-17□25F06	E,F	A/B	
						VL-17□25F13	E,F	VCL-17□25F13	E,F	A/B	
			630			VL-17□32A06	P,H	VCL-17H32A06	H	B	
			1250			VL-17□32A13	P,H	VCL-17H32A13	H	B	
			2000			VL-17□32A20	H	VCL-17H32A20	H	B	
			630			VL-17□32B06	P,H	VCL-17H32B06	H	B	
						VL-17□32B13	P,H	VCL-17H32B13	H	B	
						VL-17□32B20	P,H	VCL-17H32B20	H	B	
						VL-17□32B25	P,H	VCL-17H32B25	H	B	
					2500	VL-17□32D25	P,H	VCL-17H32D25	H	B	

Ur [kV]	Isc [kA]	Ir[A]					VCB		CRADLE		Connector
		p=130	p=150	p=210	p=265	p=275	Type	Version	Type	Version	
24	12.5			630			VL-20□13B06	G,K,H	VCL-20□13B06	G,K,H	G,K:A/B, H:B
				1250			VL-20□13B13	G,K,H	VCL-20□13B13	G,K,H	G,K:A/B, H:B
					630		VL-20□13F06	P,E,F,G,K	VCL-20□13F06	E,F,G,K	A/B
					630		VL-20□13G06	E,F	VCL-20□13G06	E,F	A/B
					1250		VL-20□13F13	P,E,F,G,K	VCL-20□13F13	E,F,G,K	A/B
					1250		VL-20□13G13	E,F	VCL-20□13G13	E,F	A/B
					630		VL-20H13D06	H	VCL-20H13D06	H	B
					1250		VL-20H13D13	H	VCL-20H13D13	H	B
		16			630		VL-20□16B06	G,K,H	VCL-20□16B06	G,K,H	G,K:A/B, H:B
					1250		VL-20□16B13	G,K,H	VCL-20□16B13	G,K,H	G,K:A/B, H:B
					630		VL-20□16F06	P,E,F,G,K	VCL-20□16F06	E,F,G,K	A/B
					630		VL-20□16G06	E,F	VCL-20□16G06	E,F	A/B
				1250		VL-20□16F13	P,E,F,G,K	VCL-20□16F13	E,F,G,K	A/B	
				1250		VL-20□16G13	E,F	VCL-20□16G13	E,F	A/B	
	25				630		VL-20H16D06	H	VCL-20H16D06	H	B
					1250		VL-20H16D13	H	VCL-20H16D13	H	B
				630		VL-20□25B06	G,K,H	VCL-20□25B06	G,K,H	G,K:A/B, H:B	
				1250		VL-20□25B13	G,K,H	VCL-20□25B13	G,K,H	G,K:A/B, H:B	
				2000		VL-20□25B20	G,H	VCL-20□25B20	G,H	G:A/B, H:B	
				630		VL-20□25F06	P,E,F,G,K	VCL-20□25F06	E,F,G,K	A/B	
				630		VL-20□25G06	E,F	VCL-20□25G06	E,F	A/B	
				1250		VL-20□25F13	P,E,F,G,K	VCL-20□25F13	E,F,G,K	A/B	
				1250		VL-20□25G13	E,F	VCL-20□25G13	E,F	A/B	
				2000		VL-20□25F20	P,E,F,K	VCL-20□25F20	E,F,K	A/B	
			2000		VL-20□25G20	E,F	VCL-20□25G20	E,F	A/B		
25.8		12.5			630			VL-25□13B06	G,K,H	VCL-25□13B06	G,K,H
	1250						VL-25□13B13	G,K,H	VCL-25□13B13	G,K,H	G,K:A/B, H:B
					630		VL-25□13F06	P,E,F,G,K	VCL-25□13F06	E,F,G,K	A/B
					630		VL-25□13G06	E,F	VCL-25□13G06	E,F	A/B
					1250		VL-25□13F13	P,E,F,G,K	VCL-25□13F13	E,F,G,K	A/B
					1250		VL-25□13G13	E,F	VCL-25□13G13	E,F	A/B
					630		VL-25H13D06	H	VCL-25H13D06	H	B
					1250		VL-25H13D13	H	VCL-25H13D13	H	B
	16				630		VL-25□16B06	G,K,H	VCL-25□16B06	G,K,H	G,K:A/B, H:B
					1250		VL-25□16B13	G,K,H	VCL-25□16B13	G,K,H	G,K:A/B, H:B
					630		VL-25□16F06	P,E,F,G,K	VCL-25□16F06	E,F,G,K	A/B
					630		VL-25□16G06	E,F	VCL-25□16G06	E,F	A/B
				1250		VL-25□16F13	P,E,F,G,K	VCL-25□16F13	E,F,G,K	A/B	
				1250		VL-25□16G13	E,F	VCL-25□16G13	E,F	A/B	
	25				630		VL-25H16D06	H	VCL-25H16D06	H	B
					1250		VL-25H16D13	H	VCL-25H16D13	H	B
				630		VL-25□25B06	G,K,H	VCL-25□25B06	G,K,H	G,K:A/B, H:B	
				1250		VL-25□25B13	G,K,H	VCL-25□25B13	G,K,H	G,K:A/B, H:B	
				2000		VL-25□25B20	G,H	VCL-25□25B20	G,H	G:A/B, H:B	
				630		VL-25□25F06	P,E,F,G,K	VCL-25□25F06	E,F,G,K	A/B	
				630		VL-25□25G06	E,F	VCL-25□25G06	E,F	A/B	
				1250		VL-25□25F13	P,E,F,G,K	VCL-25□25F13	E,F,G,K	A/B	
				1250		VL-25□25G13	E,F	VCL-25□25G13	E,F	A/B	
				2000		VL-25□25F20	P,E,F,K	VCL-25□25F20	E,F,K	A/B	
			2000		VL-25□25G20	E,F	VCL-25□25G20	E,F	A/B		
36		25					630	VL-25H25D06	H	VCL-25H25D06	H
						1250	VL-25H25D13	H	VCL-25H25D13	H	B
						2000	VL-25H25D20	H	VCL-25H25D20	H	B
						2500	VL-25H25D25	H	VCL-25H25D25-AS	H	B
						630	VL-36□25D06	P,H	VCL-36□25D06	H	P:A/B, H:B
						1250	VL-36□25D13	P,H	VCL-36□25D13	H	P:A/B, H:B
						2000	VL-36□25D20	P,H	VCL-36□25D20	H	P:A/B, H:B
						2500	VL-36□25D25	P,H	VCL-36□25D25	H	P:A/B, H:B

Note) 1. Ur = Rated voltage
 2. Isc = Rated short-circuit current
 3. Ir = Rated normal current
 4. p = Phase distance
 5. E, F and G types are cradles for MESH(Metal Enclosed Switchgear) and H type for MCSG(Metal Clad Switchgear)
 6. For the partial replacement of 7.2kV 8/12.5kA VCB, in case of using the existing old type cradle and replacing breaker only, please order type B (Compatible with existing breaker). Compatible busbars are required for fixed version.
 To replace VCB fully(breaker and cradle) please order type A for breaker and compatible cradle B.

Susol VCB

7.2/12/17.5/24/25.8/36kV (VH-06/12/17/20/25/36)

Ur [kV]	Isc [kA]	Ir[A]					VCB		CRADLE		Connector					
		p=150	p=210	p=254	p=275	p=320	Type	Version	Type	Version						
7.2	31.5	1250					LVB-06□-32L/12	P,E,F,G,G/T	LCL-06□-32D/12	E,F,G,G/T	A/B					
		2000					LVB-06□-32L/20	P,E,F,G,G/T	LCL-06□-32D/20	E,F,G,G/T	A/B					
			3150				VH-06□32B32	Fs,Gs,K,H	VCH-06□32B32	Fs,Gs,K,H	K:A/B, Fs,Gs,H:B					
							LVB-06□-32L/30	P,E,F,G/T	LCL-06□-32D/30	E,F,G,G/T						
	40	1250	1250				VH-06□40A13	P,E,F,Fs,G,Gs,K,H	VCH-06□40A13	E,F,Fs,G,Gs,K,H	P,E,F,Fs,G, Gs,K:A/B,H:B					
							LVB-06□-40L/12	P,E,F,G,G/T	LCL-06□-40D/12	E,F,G,G/T						
		2000	2000				VH-06□40A20	P,E,F,Fs,G,Gs,K,H	VCH-06□40A20	E,F,Fs,G,Gs,K,H	P,E,F,Fs,G, Gs,K:A/B,H:B					
							LVB-06□-40L/20	P,E,F,G,G/T	LCL-06□-40D/20	E,F,G,G/T						
			3150					VH-06□40B32	Fs,Gs,K,H	VCH-06□40B32	Fs,Gs,K,H	K:A/B, Fs,Gs,H:B				
								LVB-06□-40L/30	P,E,F,G/T	LCL-06□-40D/30	E,F,G,G/T					
											3150	VH-06□40D32	K,H	VCH-06□40D32	K,H	K:A/B, H:B
											4000	VH-06□40D40	P,K,H	VCH-06□40D40	K,Ha,Hb	
	50		1250				VH-06□50B13	P,H	VCH-06H50B13	H	B					
							VH-06□50B20	P,H	VCH-06H50B20	H						
								VH-06□50D25	P,H	VCH-06H50D25	H	B				
								VH-06□50D32	P,H	VCH-06H50D32	H					
								VH-06□50D40	P,K,H	VCH-06□50D40	K,Ha,Hb	B				
								VH-06H50L50	H	VCH-06Ha50L50	Ha					
		12	31.5	1250	1250				LVB-12G-32L/12-T2	G/T	LCL-12G-32D/12-T2	G/T	A/B			
									LVB-12G-32L/20-T2	G/T	LCL-12G-32D/20-T2	G/T	A/B			
	3150							VH-12□32B32	Gs,K,H	VCH-12□32B32	Gs,K,H	K:A/B, Gs,H:B				
								LVB-12G-32L/30-T2	G/T	LCL-12G-32D/30-T2	G/T		A/B			
40	1250		1250				VH-12□40A(K)13	Gs,K,H	VCH-12□40A(K)13	Gs,K,H	Gs,K:A/B, H:B					
							LVB-12G-40L/12-T2	G/T	LCL-12G-40D/12-T2	G/T		A/B				
	2000		2000					VH-12□40A(K)20	Gs,K,H	VCH-12□40A(K)20	Gs,K,H	K:A/B, Gs, H:B				
								LVB-12G-40L/20-T2	G/T	LCL-12G-40D/20-T2	G/T		A/B			
			1250					VH-12□40B13	K,H	VCH-12□40B13	K,H	B				
								VH-12□40B20	K,H	VCH-12□40B20	K,H					
			3150					VH-12□40B32	Gs,K,H	VCH-12□40B32	Gs,K,H	K:A/B, Gs,H:B				
								LVB-12G-40L/30-T2	G/T	LCL-12G-40D/30-T2	G/T		A/B			
										3150	VH-12H40D32	H	VCH-12H40D32	H	B	
										4000	VH-12□40D40	P,K,H	VCH-12□40D40	K,Ha,Hb		B
50			1250				VH-12□50B13	P,H	VCH-12H50B13	H	B					
							VH-12□50B20	P,H	VCH-12H50B20	H						
								VH-12□50D25	P,H	VCH-12H50D25	H	B				
								VH-12□50D32	P,H	VCH-12H50D32	H					
								VH-12□50D40	P,K,H	VCH-12□50D40	K,Ha,Hb	B				
								VH-12H50L50	H	VCH-12Ha50L50	Ha					
	17.5	31.5		3150				VH-17H32B32	H	VCH-17H32B32	H	B				
								VH-17H32D32	H	VCH-17H32D32	H					
40		1250						VH-17□40B13	K,H	VCH-17□40B13	K,H	K:A/B, H:B				
								VH-17□40B20	K,H	VCH-17□40B20	K,H					
			2000						VH-17H40B32	H	VCH-17H40B32	H	B			
									VH-17K40C32	K	VCH-17K40C32	K				
				3150					VH-17H40D32	H	VCH-17H40D32	H	B			
									VH-17□40D40	P,K,H	VCH-17□40D40	Ha,Hb				

Ur [kV]	Isc [kA]	Ir[A]				VCB		CRADLE		Connector
		p=150	p=210	p=275	p=300	Type	Version	Type	Version	
17.5	50		1250			VH-17□50B13	P,H	VCH-17H50B13	H	B
			2000			VH-17□50B20	P,H	VCH-17H50B20	H	B
				2500		VH-17□50D25	P,H	VCH-17H50D25	H	B
				3150		VH-17□50D32	P,H	VCH-17H50D32	H	B
				4000		VH-17□50D40	P,H	VCH-17□50D40	Ha,Hb	B
24	25			2500		VH-20□25D25	P,H	VCH-20H25D25	H	B
	31.5		1250			VH-20□32B13	P,H	VCH-20H32B13	H	B
								VCH-20H32F13	H	B
			2000			VH-20□32B20	P,H	VCH-20H32B20	H	B
								VCH-20H32F20	H	B
				1250		VH-20□32D13	P,H	VCH-20H32D13	H	B
			2000		VH-20□32D20	P,H	VCH-20H32D20	H	B	
			3150		VH-20□32D32	P,H	VCH-20H32D32	H	B	
	40		1250			VH-20□40B13	P,H	VCH-20H40B13	H	B
								VCH-20H40F13	H	B
			2000			VH-20□40B20	P,H	VCH-20H40B20	H	B
								VCH-20H40F20	H	B
				1250		VH-20□40D13	P,H	VCH-20H40D13	H	B
			2000		VH-20□40D20	P,H	VCH-20H40D20	H	B	
		3150		VH-20□40D32	P,H	VCH-20H40D32	H	B		
25.8	25			2500		VH-25□25D25	P,H	VCH-25H25D25	H	B
	31.5		1250			VH-25□32B13	P,H	VCH-25H32B13	H	B
								VCH-25H32F13	H	B
			2000			VH-25□32B20	P,H	VCH-25H32B20	H	B
								VCH-25H32F20	H	B
				1250		VH-25□32D13	P,H	VCH-25H32D13	H	B
			2000		VH-25□32D20	P,H	VCH-25H32D20	H	B	
			3150		VH-25□32D32	P,H	VCH-25H32D32	H	B	
	40		1250			VH-25□40B13	P,H	VCH-25H40B13	H	B
								VCH-25H40F13	H	B
			2000			VH-25□40B20	P,H	VCH-25H40B20	H	B
								VCH-25H40F20	H	B
				1250		VH-25□40D13	P,H	VCH-25H40D13	H	B
			2000		VH-25□40D20	P,H	VCH-25H40D20	H	B	
		3150		VH-25□40D32	P,H	VCH-25H40D32	H	B		
36	25				1250	VH-36□25E13	P,H	VCH-36H25E13	H	B
					2000	VH-36□25E20	P,H	VCH-36H25E20	H	B
					3150	VH-36□25E32	P,H	VCH-36H25E32	H	B
	31.5				1250	VH-36□32E13	P,H	VCH-36H32E13	H	B
					2000	VH-36□32E20	P,H	VCH-36H32E20	H	B
					3150	VH-36□32E32	P,H	VCH-36H32E32	H	B
	40				1250	VH-36□40E13	P,H	VCH-36H40E13	H	B
					2000	VH-36□40E20	P,H	VCH-36H40E20	H	B
					3150	VH-36□40E32	P,H	VCH-36H40E32	H	B

- Note) 1. Ur = Rated voltage
 2. Isc = Rated short-circuit current
 3. Ir = Rated normal current
 4. p = Phase distance
 5. H type is MCSG style drawable type with a box type cradle for CB compartment construction.
 6. G/T types are MCSG style drawable types with a cradle for building in the switchgear, not a box type. (K of VCL type name indicates 4000A)
 Example of G/T type : LVB-06G-32L/12-T2, LCL-06G-32D/12-T2
 7. G/T types use LVB and LCL names.
 8. E, F and G types provide cradles for MESG(Metal Enclosed Switchgear) and H, G/T types for MCSG(Metal Clad Switchgear).
 9. In case of 7.2/12kV, 31.5kA/40kA H type: Please contact us.

Control circuit diagram (VL-06)

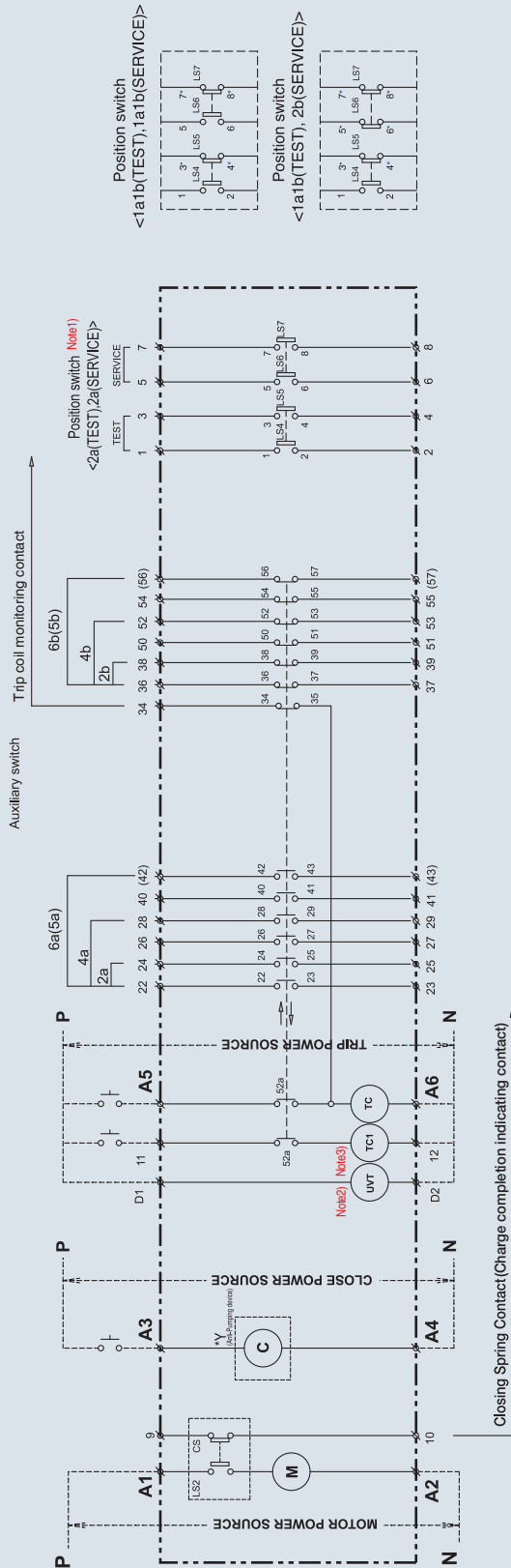

<Connecting terminal arrangement>

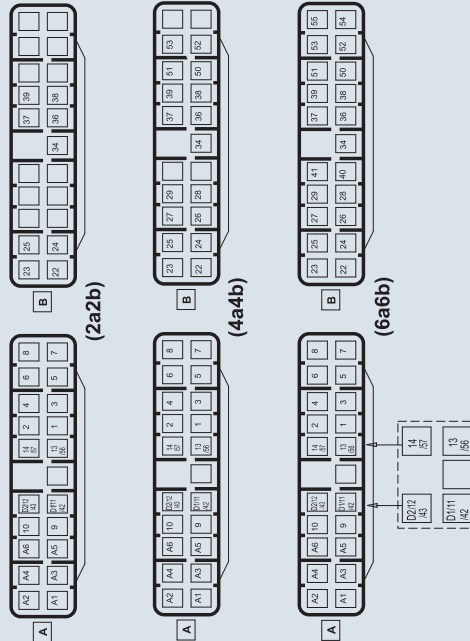

0: External terminal of VCB
 S2: Vacuum circuit breaker
 M: Spining charging motor
 TC: Trip coil
 TC1: Secondary trip coil
 C: Closing coil
 UVT: Under voltage trip
 S2a: Auxiliary switch (a)
 S2b: Auxiliary switch (b)
 CTC: Current trip coil
 CTC1: Secondary Current trip coil
 CS: Closing spring charged Limit Switch
 Y: Anti-Pumping Device
 Anti-Pumping Device is installed inside as standard IEC62271-100 3.6.128

SW No.	TEST : 2a		SERVICE : 2a	
	A3	A4	A4	A5
LS4	Close at TEST position	Close at TEST position	Close at TEST position	Close at TEST position
LS5	OPEN at TEST position	Close at TEST position	Close at TEST position	OPEN at TEST position
LS6	OPEN at SERVICE position	Close at SERVICE position	Close at SERVICE position	Close at SERVICE position
LS7	OPEN at SERVICE position	Close at SERVICE position	Close at SERVICE position	OPEN at SERVICE position

- Note) 1. Position SW : TEST 2a, SERVICE 2a (Terminal No. : 1, 2, 3, 4, 5, 6, 7, 8)
 * TEST position 1a1b, SERVICE position 1a1b/2b are available
 (* marked contact is b contact)
 2. UVT : Under Voltage Trip (Terminal No. : D1, D2)
 3. TC1 : Secondary Trip Coil (Spare trip coil, terminal No. : 11, 12)
 4. CTC : Current Trip Coil (Terminal No. : A5, A6)
 CTC1 : Secondary Current Trip Coil (Terminal No. : 11, 12)
 5. Close and Trip coil is One Pulse type, excluding trip coil (DC110/220V)
 6. In above optional accessories, UVT/TC and TC1 can not be selected simultaneously
 7. UVT, TC1 are selected, Maximum auxiliary switch is 4#40
 8. Above circuit diagram is based on 'OFF' status of VCB and closing spring is charged
 9. Please make sure that keep the direction of PN on this circuit diagram
 *Y : Anti-pumping device
 Anti-pumping device Y supply anti-pumping function to VCB as below. It is composed with circuit in close coil and mechanism.
 In case the closing coil(C) becomes permanently energized, the circuit breaker remains in the open position after it has been opened,
 either by manual or electrical operation. The circuit breaker can be closed only if the closing coil(C) is momentarily de-energized.

Control circuit diagram (VL-06/12/17/20/25/36)

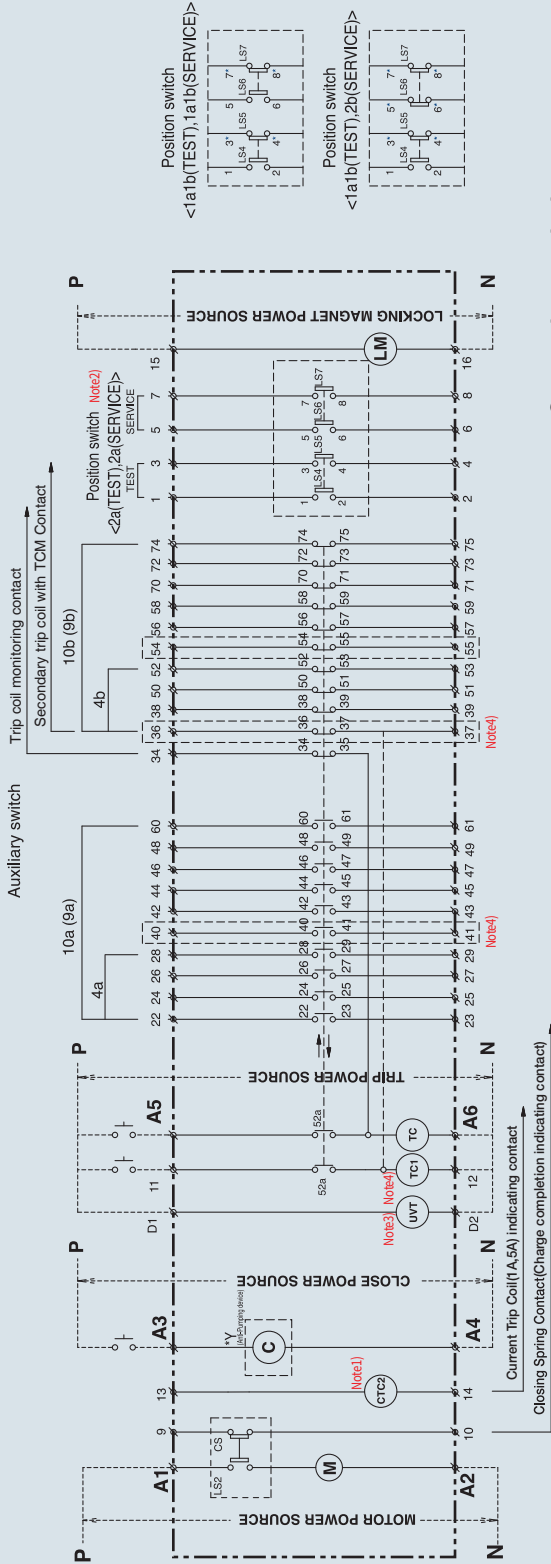

<Connecting terminal arrangement>

- Ø: External terminal of VCB
- 52 : Vacuum circuit breaker
- M : Spring charging motor
- TC : Trip coil(SHT)
- TC1 : Secondary Trip coil(SHT1)
- C : Closing coil(CC)
- UVT : Under Voltage Trip
- 52a : Auxiliary switch (NO)
- 52b : Auxiliary switch (NC)
- LS2 : Motor stop limit switch
- CTC : Current Trip coil(A)
- CTC1 : Secondary Current Trip coil(3A)
- CTC2 : Current Trip coil(A,5A)
- CTC3 : Current Trip coil(A,5A)
- LET : Low Energy Trip Device(25m,100m)
- CS : Closing spring charged indication limit switch

SW No.	TEST : 1a1b	TEST : 2a	TEST : 1a1b
LS4	SERVICE : 2b	SERVICE : 2a	SERVICE : 1a1b
LS5	A3	A4	A5
LS6	Close at TEST position	Close at TEST position	Close at TEST position
LS7	Open at TEST position	Open at TEST position	Open at TEST position
LS8	Close at SERVICE position	Close at SERVICE position	Close at SERVICE position
LS9	Open at SERVICE position	Open at SERVICE position	Open at SERVICE position

- LM : Locking magnet(only withdrawable type)

- Note) 1. CTC2 : Current Trip Coil(Terminal No. : 13,14)
 2. Position S/W - TEST 2a, SERVICE 2a(Terminal No. : 1,2,3,4,5,6,7,8)
 - TEST position 1a1b, SERVICE position 1a1b/2b are available.
 (* marked contact is b contact)
3. UVT - Under Voltage Trip (Terminal No.:D1, D2)
 4. TCI - Secondary Trip Coil (Terminal No.:11,12)
 In case TCI is selected and auxiliary switch is 10a10b, Some 'a' contact (Terminal No.: 40,41) and 'b' contact(Terminal No.:54, 55) are not available.
5. Secondary Trip Coil Monitoring Contact (Terminal No. :36)
 In case Secondary Trip Coil TCM Contact is selected and auxiliary switch is 9a8b, Some 'a' contact (Terminal No.: 40,41) and 'b' contact(Terminal No.:36, 37) are not available.
6. CTC - Current Trip Coil (Terminal No. : A5,A6)
 CTC1 - Secondary Current Trip Coil (Terminal No. : 11,12)
 CTC2 - Current Trip Coil (Terminal No. : 13,14)
 CTC3 - Current Trip Coil (Terminal No. : D1,D2)
7. LET - Low Energy Trip Device (Terminal No. : 13,14)
 8. LM - Locking Magnet (Terminal No.:15, 16). In case of B type connector is available
9. Close and Trip coil is One Pulse type, excluding Trip coil (DC110, 220V)
 10. In above optional accessories, UVT,CTC and TCI can not be selected simultaneously.
 11. Above circuit diagram is based on "OFF" state of VCB and closing spring is charged.
 12. Please, keep the direction of PN on this circuit diagram.
 *Y : Anti-pumping device
 Anti-pumping device Y supply anti-pumping function to VCB as below. It is composed with circuit in close coil and mechanism. In case the closing coil(C) becomes permanently energized, the circuit breaker remains in the open position after it has been opened, either by manual or electrical operation. The circuit breaker can be closed only if the closing coil(C) is momentarily de-energized.

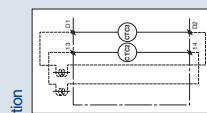
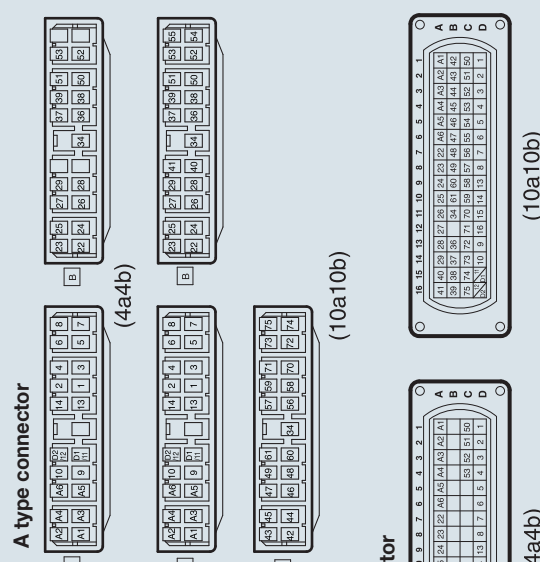

Control circuit diagram (VH-06/12/17/20/25/36)

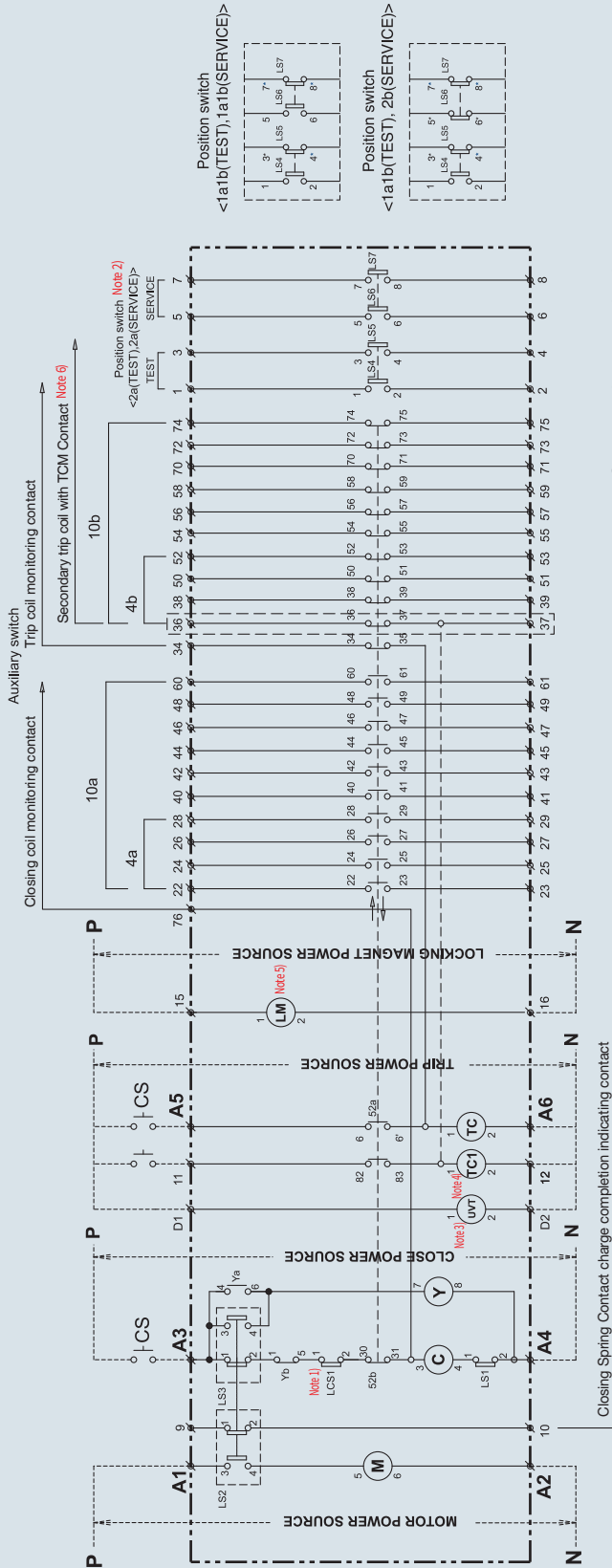

<Connecting terminal arrangement>

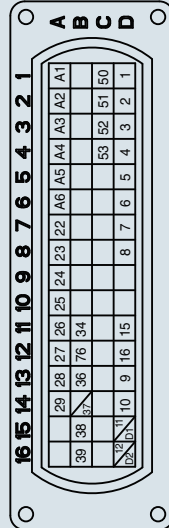

(4a4b)

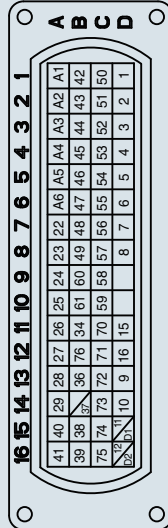

(10a10b)

SW No.	TEST : 1a1b	SERVICE : 2a	TEST : 1a1b	SERVICE : 1a1b
LS4	Close at TEST position	Close at TEST position	A4	A5
LS5	OPEN at TEST position	Close at TEST position	A4	A5
LS6	OPEN at SERVICE position	Close at SERVICE position	A4	A5
LS7	OPEN at SERVICE position	Close at SERVICE position	A4	A5

LM: Locking magnet (only withdrawable type)

- Ø: External terminal of VCB
- SZ: Vacuum circuit breaker
- M: Spring charging motor
- TC: Trip coil
- TC1: Secondary trip coil
- C: Close coil
- Y: Anti-pump relay
- UVT: Under-voltage trip
- 52a: Auxiliary switch (a)
- 52b: Auxiliary switch (b)
- LS1: Close interlock limit switch (only withdrawable type)
- LS2: Motor stop, close spring charged indication limit switch

- Note
- LCS1: Latch Checking Switch
 - Position S/W - TEST 2a, SERVICE 2a(Terminal No. 1, 2, 3, 4, 5, 6, 7, 8) 1a1b at TEST position and 1a1b at SERVICE position are also available. (In case of 1a1b *marked contact is b - normally open contact)
 - UVT - Under Voltage Trip (Terminal No. D1, D2)
 - TC1 - Secondary Trip Coil (Spare trip coil, terminal No. 11, 12)
 - LM - Locking Magnet (Terminal No. 15, 16), Type H only withdrawable type.
 - Secondary Trip Coil monitoring contact (Terminal No. 36)
 - b contact(36, 37) is not available if Trip Coil monitoring contact is applied to Secondary Trip Coil.
 - Above options TCI and UVT can not be used simultaneously.
 - LS1(closing-interlock Limit-switch) is not available for fixed version
 - Above circuit diagram is based on 'OFF' status of VCB and closing spring is charged.
 - Please make sure that keep the direction of P, N on this circuit diagram.

Compartment Control circuit diagram

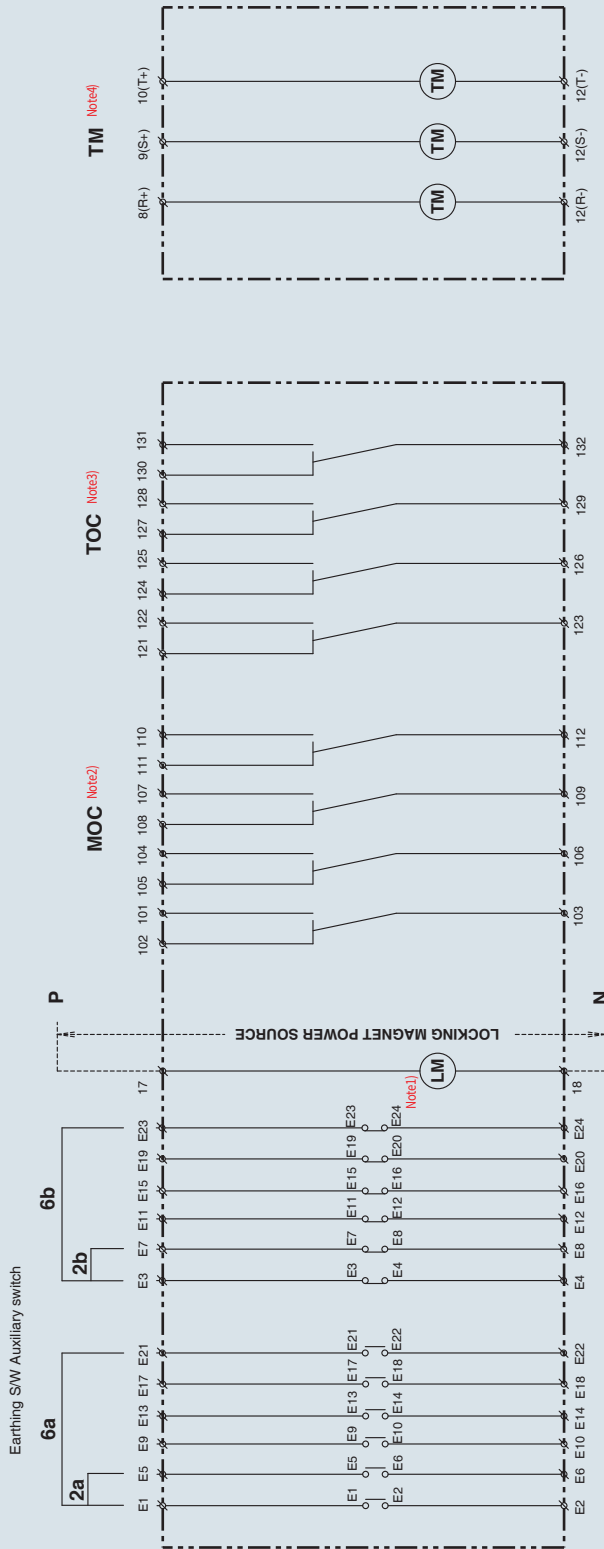

Ø: External terminals for auxiliary contacts and locking magnet

LM: Locking magnet for earthing switch

MOC: Mechanism operated cell switch (for H type cradle)

TOC: Truck operated cell switch (for H type cradle)

TM: Temperature alarm (for H type cradle)

- Note 1. LM - If it is energized with the rated power the earthing switch can be closed or opened (for H type cradle)
2. MOC - This auxiliary switch is used to indicate the Close/Open of VCB (for H type cradle)
3. TOC - This auxiliary switch is used to indicate the 'SERVICE' position of VCB (for H type cradle)
4. TM - Temperature Alarm Unit displays the input temperature detected through the temperature sensor installed in H-type cradle. Temperature sensor can be installed in each phase and can be connected with the temperature module.
5. Please make sure that keep the direction of P, N on this circuit diagram.

* Above circuit diagram is based on the status that the earthing S/W is Open and the breaker is at Test or between Test and Service position. MOC indicates the Open of the breaker. If the breaker is Closed from Service, the contacts configuration is displayed on the contrary.

Susol VCB

VL-06 Dimensions

7.2kV, 8/12.5kA, 400/630A

Withdrawable (Compatible with existing breaker E/F/G type, phase distance 130mm)

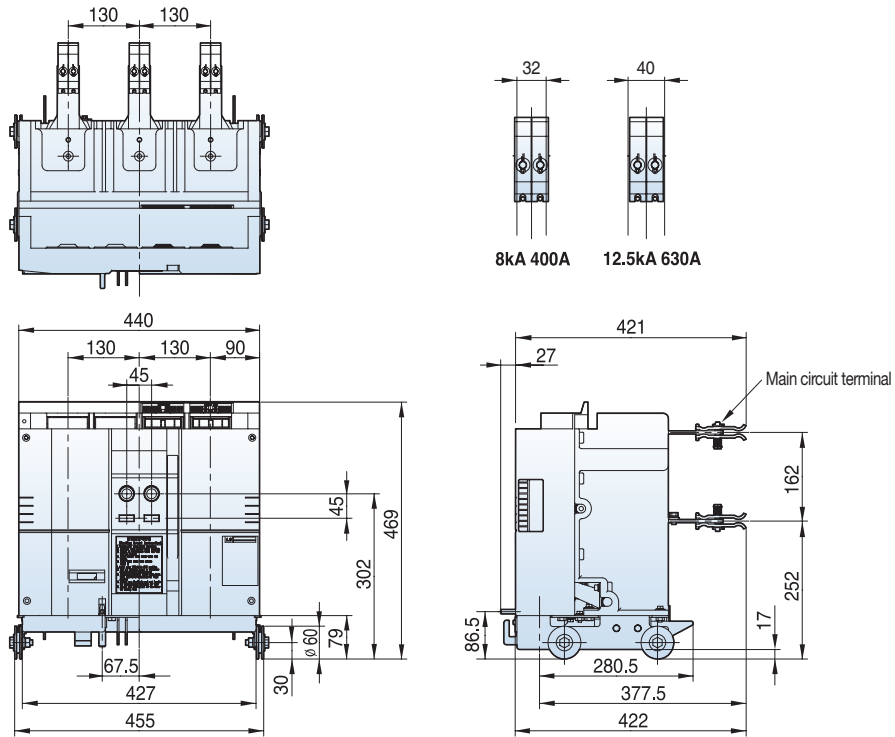

Withdrawable (E type cradle, phase distance 130mm)

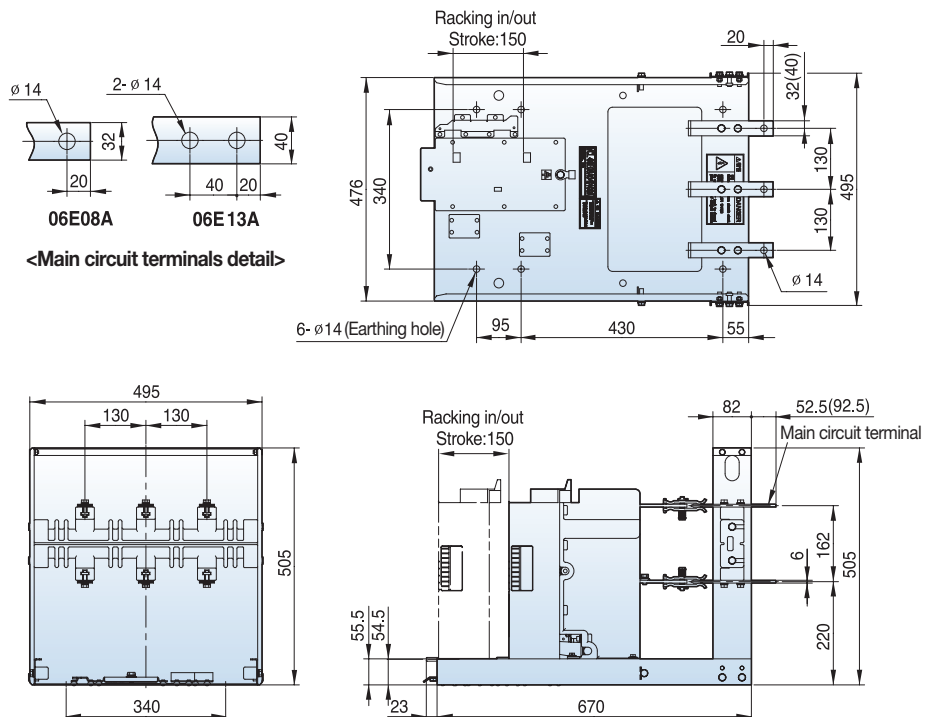

7.2kV, 8/12.5kA, 400/630A

Withdrawable (F type cradle, phase distance 130mm)

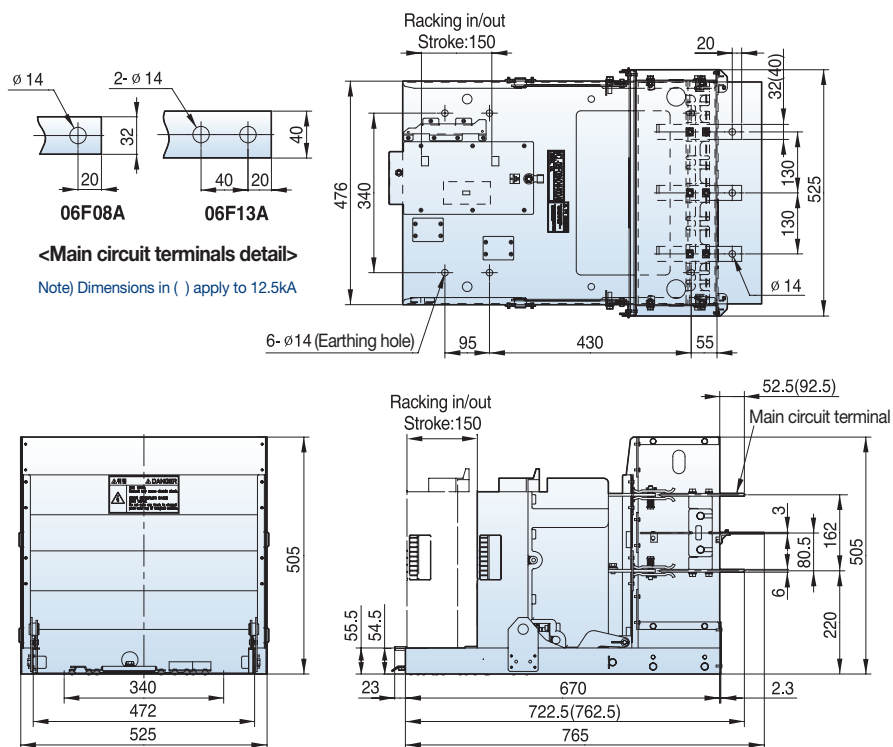

Withdrawable (G type cradle, phase distance 130mm)

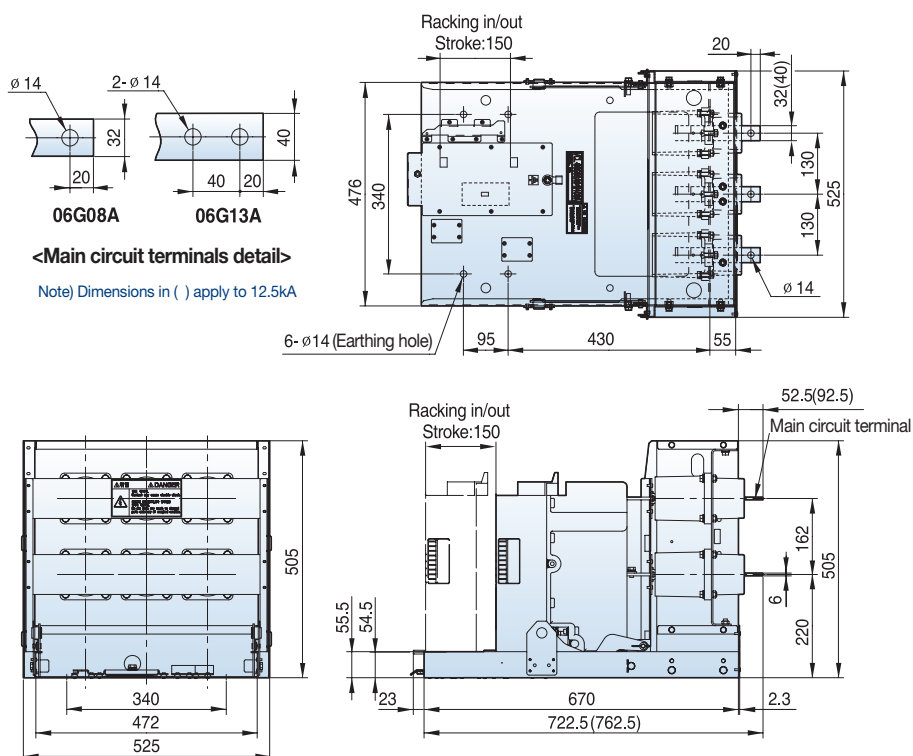

Susol VCB

VL- 06/12/17/20/25/36 Dimensions

7.2kV, 20/25kA, 630/1250A

Withdrawable (E type unit, phase distance 150mm)

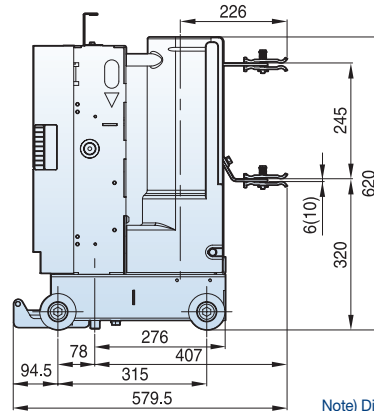
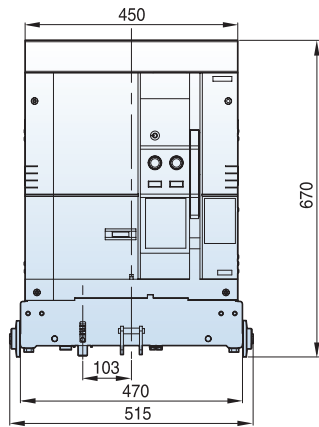
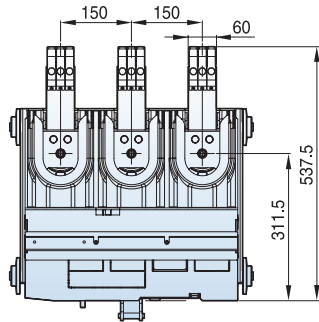

Note) Dimensions in () apply to 1250A

Withdrawable (E type cradle, phase distance 150mm)

Rating	630A	1250A
A	6	10
B	55	60
C	95	90

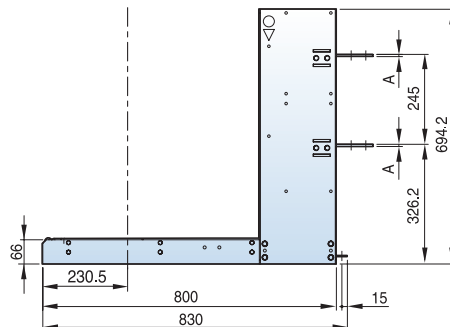
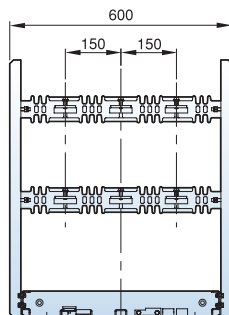
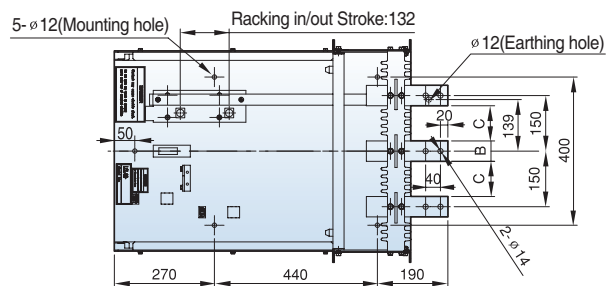

* Please be informed that the switchgear IP cover has to be back of - - - - mark.

Susol VCB

VH- 06/12/17/20/25/36 Dimensions

7.2kV, 31.5/40kA, 1250/2000A

Withdrawable (E, F G type unit, phase distance 150mm)

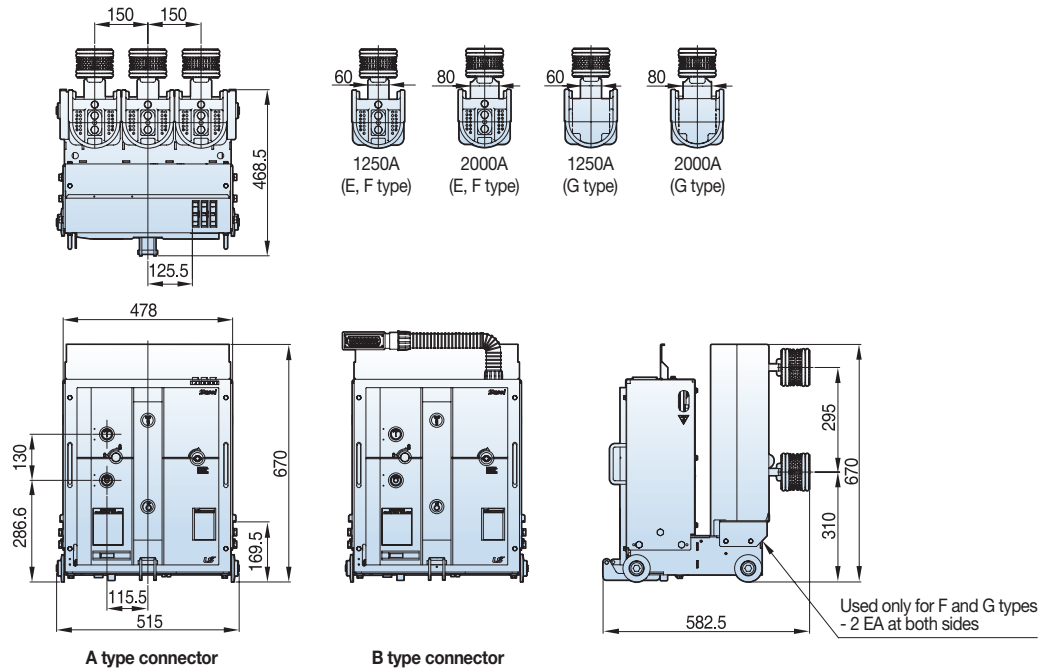

Withdrawable (E type cradle, phase distance 150mm)

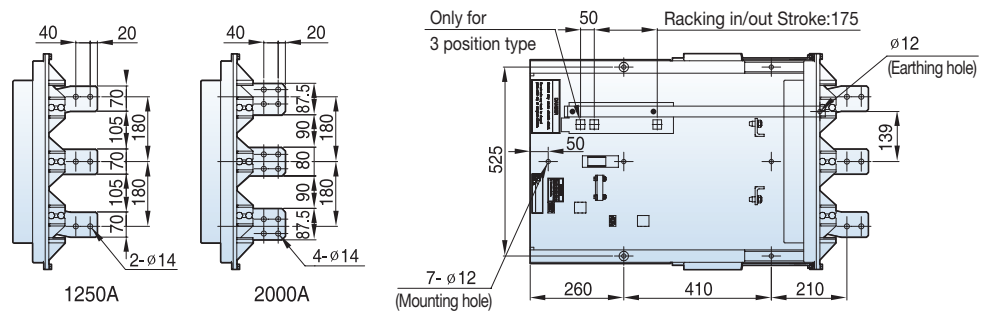

Rating	1250A	2000A
A	10	20

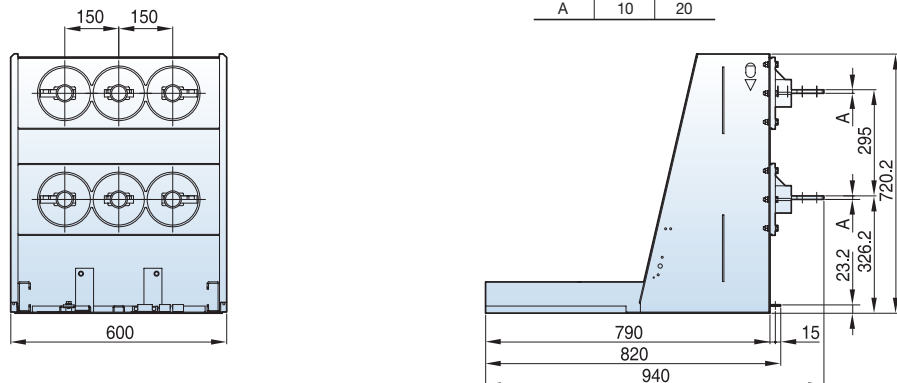

36kV, 25/31.5/40kA, 1250/2000A

Withdrawable (H type unit, phase distance 300mm)

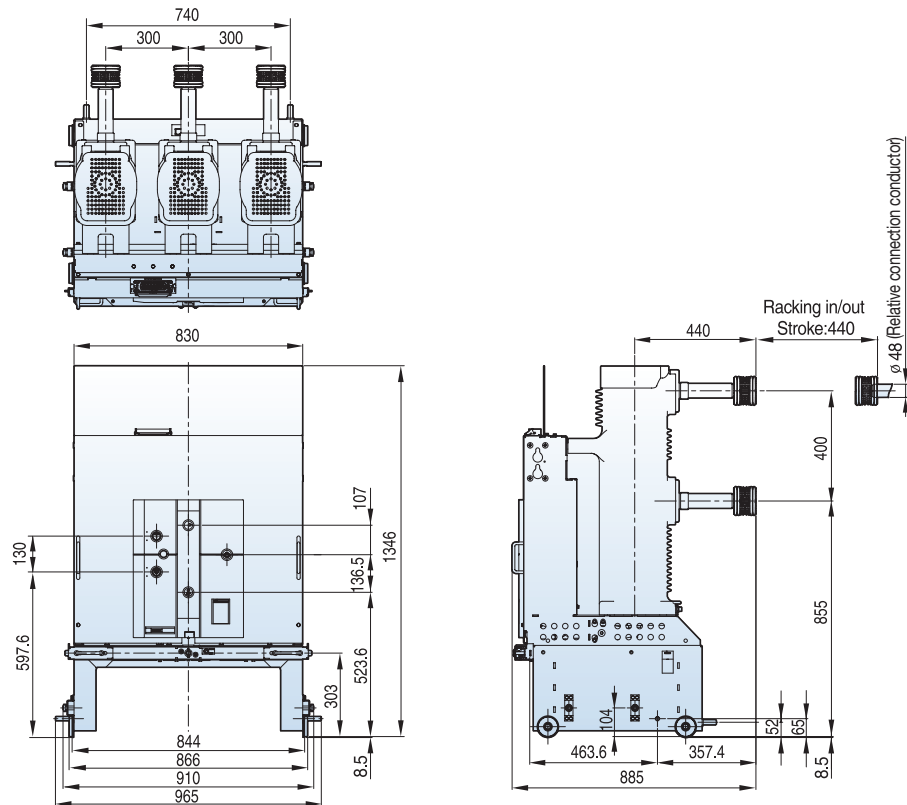

Withdrawable (H type cradle, phase distance 300mm)

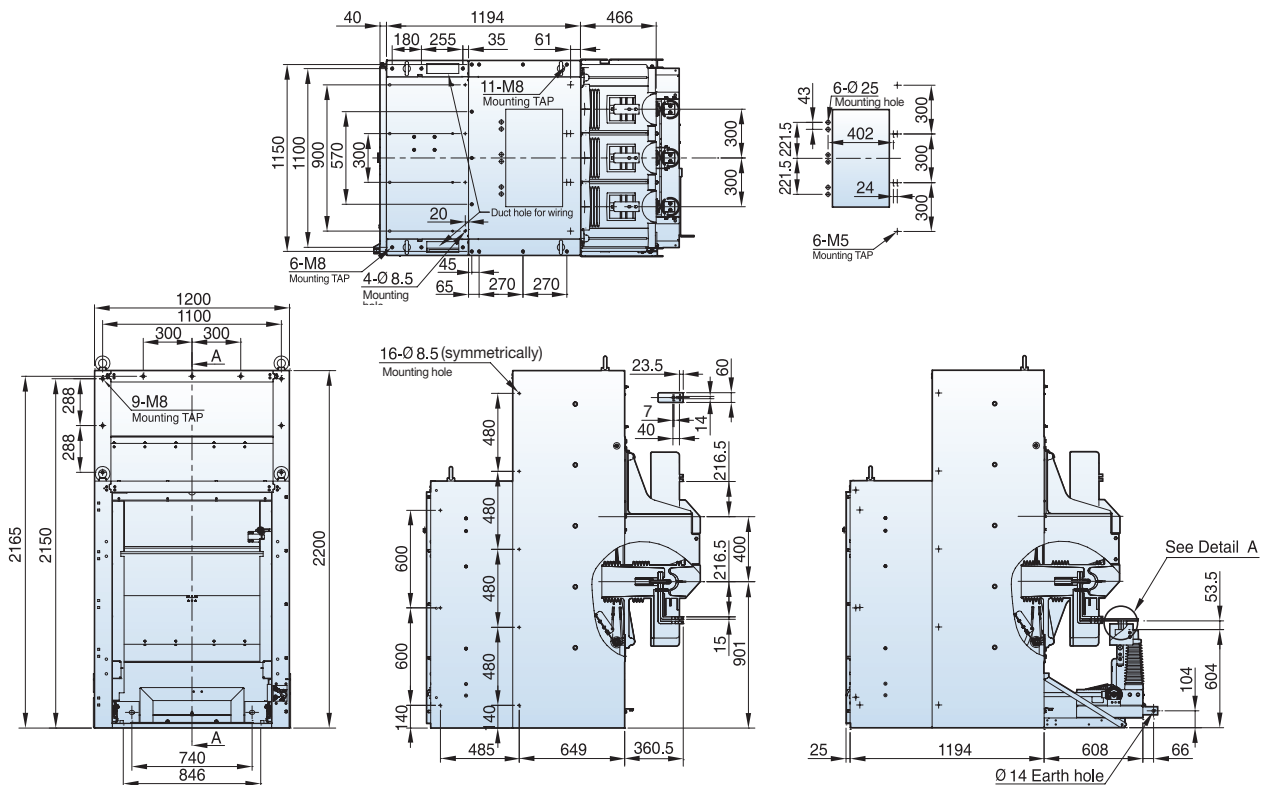

Memo

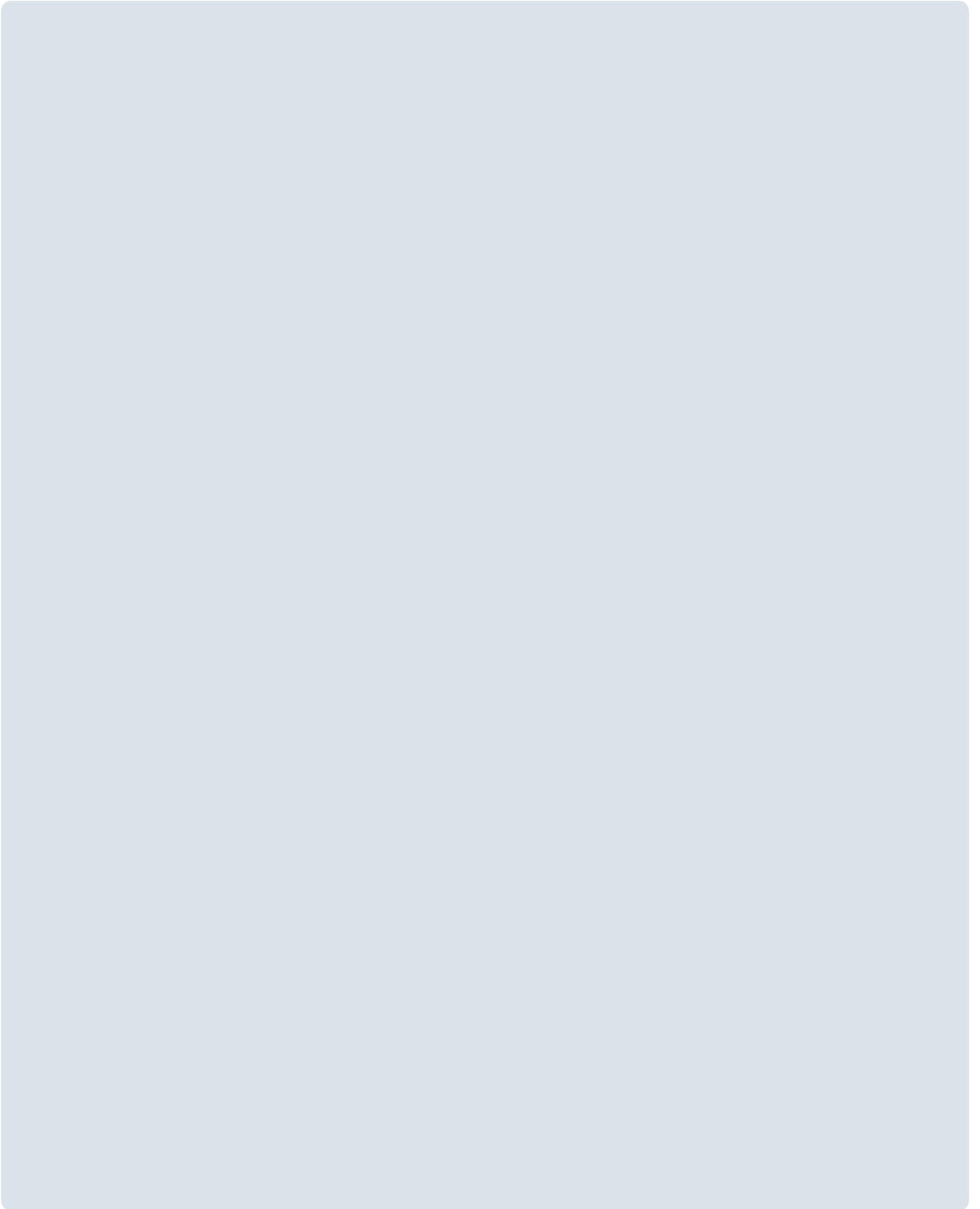

MS

Contactors and Overload relays

Sealed structure has improved its safety features so that no arc flash is exposed. In order to emphasize its durability as an industrial device, Metasol series adopt simple design form and sophisticated shape applying diamond cut concepts on product surface.

- Advanced technology & Expert solution
 - Offering economical solution with compact size & easy connection
 - Ensure reliability in the system: Type II Coordination
 - Perfect system with peripheral devices
 - Environment friendly product: complies with International environment standard RoHS
 - 25 Models in 9 Frames
-
- Compact design for space saving
 - DIN rail and screw mountable (upto 150AF)
 - Finger-proof design
 - World class products conforming to IEC and UL standards



Metasol Contactors

MC type Magnetic Contactors



Frame size				18AF				22AF				
Type	Screw clamp terminals			MC-6a	MC-9a	MC-12a	MC-18a	MC-9b	MC-12b	MC-18b	MC-22b	
	Lug clamp terminals			-	-	-	-	-	-	-	-	
Number of poles				3P				3P				
Rated operational voltage, Ue				690V				690V				
Rated insulation voltage, Ui				690V				690V				
Rated frequency				50/60Hz				50/60Hz				
Rated impulse withstand voltage, Uimp				6kV				6kV				
Maximum operating rate in operating cycles per hour(AC3)				1,800 operations per hour				1,800 operations per hour				
Durability (mil. operations)	Mechanical			1500				1500				
	Electrical			250				250				
Current and power (IEC)	AC-1, Thermal current	A		25	25	25	32	25	27	32	45	
		AC-3	200/240V	kW	2.2	2.5	3.5	4.5	2.5	3.5	4.5	5.5
			380/440V	kW	9	11	13	18	11	13	18	22
			A		3	4	5.5	7.5	4	5.5	7.5	11
			500/550V	kW	7	9	12	18	9	12	18	22
				A		3	4	7.5	7.5	4	7.5	7.5
			690V	kW	6	7	12	13	7	12	13	20
				A		3	4	7.5	7.5	4	7.5	7.5
			1000V	kW	4	5	9	9	6	9	9	18
				A		-	-	-	-	-	-	-
Rated Short-time withstand current (IEC 60947)	1s	A		210	250	280	300	250	280	300	400	
	10s	A		105	110	120	130	110	120	154	186	
	30s	A		70	70	80	85	70	80	100	130	
	1min	A		61	61	61	70	61	61	84	90	
	3min	A		40	45	47	50	45	50	60	60	
	10min	A		30	30	30	40	30	30	40	50	
Rating (UL)	Continuous current	A		25	25	25	32	25	25	40	40	
		Single phase	110~120V	HP	0.5	0.5	0.75	1	0.5	0.75	1	2
			220~240V	HP	1.5	1.5	2	3	1.5	2	3	3
		Three phase	200~208V	HP	2	2	3	7.5	2	3	7.5	7.5
			220~240V	HP	3	3	5	7.5	3	5	7.5	10
			440~480V	HP	5	5	7.5	10	5	7.5	10	15
		550~600V	HP	7.5	7.5	10	15	7.5	10	15	20	
NEMA size			00	00	0	1	00	0	1			
Size and weight	AC control	Weight	kg	0.33				0.34				
		Size(W×H×D)	mm	45×73.5×80.4				45×73.5×87.4				
	DC control	Weight	kg	0.4				0.41				
		Size(W×H×D)	mm	45×73.5×96.6				45×73.5×103.6				
Auxiliary(standard)				1NO or NC				1NO1NC				
Auxiliary	Side mount			UA-1				UA-1				
	Front mount			UA-2, UA-4				UA-2, UA-4				



40AF	
MC-32a	MC-40a
•	•
-	-
3P	
1000V	
1000V	
50/60Hz	
8kV	
1,800 operations per hour	
1200	
200	
55	60
7.5	11
32	40
15	18.5
32	40
18.5	22
28	32
18.5	22
20	23
22	22
17	17
600	700
260	300
160	190
100	120
70	80
55	65
50	60
50	60
2	3
5	7.5
7.5	15
10	15
20	30
25	30
1P	2
0.55	
69×83×90	
0.77	
69×83×117.1	
2NO2NC	
UA-1	
UA-2, UA-4	

65AF	
MC-50a	MC-65a
•	•
•	•
3P	
1000V	
1000V	
50/60Hz	
8kV	
1,200 operations per hour	
1200	
200	
100	115
15	18.5
55	65
22	30
50	65
30	33
43	60
30	33
28	35
30	30
23	23
1000	1050
550	700
330	380
250	270
150	200
90	120
87	96
70	100
3	5
10	15
20	25
25	30
40	50
50	60
1.05	
79×106×119	
1.3	
79×106×146.4	
2NO2NC	
UA-1	
UA-2, UA-4	

100AF		
MC-75a	MC-85a	MC-100a
•	•	•
•	•	•
3P		
1000V		
1000V		
50/60Hz		
8kV		
1,200 operations per hour		
1200		
200		100
125	135	160
22	25	30
75	85	105
37	45	55
75	85	105
37	45	55
64	75	85
37	45	55
42	45	65
37	37	37
28	28	28
1100	1200	1320
750	800	900
400	450	500
300	350	400
220	270	270
140	170	180
114	150	160
110	135	160
5	7.5	10
15	15	20
25	30	30
30	40	40
50	60	75
60	75	75
1.93		
94×140×135.8		
2.8		
94×140×172.3		
2NO2NC		
UA-1		
UA-2, UA-4		

150AF	
MC-130a	MC-150a
•	•
•	•
3P	
1000V	
1000V	
50/60Hz	
8kV	
1,200 operations per hour	
500	
100	
200	250
37	45
130	150
60	75
130	150
60	70
90	100
55	55
60	60
75	75
50	50
1350	1800
950	1200
700	800
550	600
350	450
200	300
175	280
200	250
10	15
20	25
40	40
40	50
75	100
75	75
2.4	
119×158×130.3	
2NO2NC	
UA-1	
UA-2, UA-4	

Metasol Contactors

MC type Magnetic Contactors



Frame size				225AF		400AF		
Type	Screw clamp terminals			MC-185a	MC-225a	MC-265a	MC-330a	MC-400a
	Lug clamp terminals			-	-	-	-	-
Number of poles				3P		3P		
Rated operational voltage, Ue				1000V		1000V		
Rated insulation voltage, Ui				1000V		1000V		
Rated frequency				50/60Hz		50/60Hz		
Rated impulse withstand voltage, Uimp				8kV		8kV		
Maximum operating rate in operating cycles per hour(AC3)				1,200 operations per hour		1,200 operations per hour		
Durability (mil. operations)	Mechanical			500		500		250
	Electrical			100		100		50
Current and power (IEC)	AC-1, Thermal current	200/240V	A	300	350	400	500	520
			kW	55	75	80	90	125
	AC-3	380/440V	A	185	225	265	330	400
			kW	90	132	147	160	200
		500/550V	A	185	225	265	330	400
			kW	110	132	147	160	225
		690V	A	180	200	225	280	350
			kW	110	140	160	200	250
		1000V	A	120	150	185	220	300
			kW	132	132	147	147	147
		A	90	90	105	105	105	
Rated Short-time withstand current (IEC 60947)	1s	A	2000	2500	3500	4000	4600	
	10s	A	1500	1700	2400	3000	4400	
	30s	A	1000	1200	1500	2500	2974	
	1min	A	800	1000	1100	1700	1846	
	3min	A	520	700	800	1000	1313	
	10min	A	350	500	600	620	760	
	≥15min	A	320	400	500	553	699	
Rating (UL)	Continuous current		A	300	350	400	500	520
	Single phase	110~120V	HP	15	15	-	-	-
		220~240V	HP	30	40	-	-	-
	Three phase	200~208V	HP	60	60	75	100	125
		220~240V	HP	60	75	100	100	150
		440~480V	HP	125	150	200	200	300
		550~600V	HP	125	150	200	200	300
NEMA size					5			
Size and weight	AC control	Weight	kg	5.4		9.2		
		Size(W×H×D)	mm	138×203×185.1		163×243×204.4		
	DC control	Weight	kg					
		Size(W×H×D)	mm					
Auxiliary(standard)				2NO2NC		2NO2NC		
Auxiliary	Side mount			AU-100, AU-100E (Max.4NO4NC)		AU-100, AU-100E (Max.4NO4NC)		
	Front mount			-		-		

Metasol Contactors



MC type Magnetic Contactors (4pole)

Frame size				18AF			
Type				MC-6a/4	MC-9a/4	MC-12a/4	MC-18a/4
Screw clamp terminal				●			
Number of poles				4P			
Rated operational voltage (Ue)				690V			
Rated insulation voltage (Ui)				690V			
Rated frequency				50/60Hz			
Rated impulse withstand voltage, Uimp				6kV			
Maximum operating rate in operating cycles per hour(AC3)				1,800 operations per hour			
Durability		Mechanical		1500			
		Electrical		50		80	
Current and Power (IEC)	Thermal current		A	25	25	25	40
	AC-1	200/240V	kW	9	9	9	15
			A	25	25	25	40
	380/400V	kW		17	17	17	27
		A		25	25	25	40
	500/550V	kW		21	21	21	35
		A		25	25	25	40
	690V	kW		27	27	27	44
A			25	25	25	40	
UL rating (UL)	Continuous current		A	25	25	25	32
	Single	110~120V	HP	0.5	0.5	0.75	1
		Phase	220~240V	HP	1.5	1.5	2
	Three	200~208V	HP	2	2	3	7.5
		Phase	220~240V	HP	3	3	5
	440~480V	HP	5	5	7.5	10	
		550~600V	HP	7.5	7.5	10	15
Size and weight	AC	Weight	kg	0.33			
		Control Size(W×H×D)	mm	45×73.5× 80.4			
	DC	Weight	kg	0.4			
		Control Size(W×H×D)	mm	45×73.5×96.6			
Auxiliary(standard)				-			
Auxiliary	Side Mount			UA-1			
	Front Mount			UA-2, UA-4			





22AF	40AF		85AF			
MC-22a/4	MC-32a/4	MC-40a/4	MC-50a/4	MC-65a/4	MC-75a/4	MC-85a/4
●	●		●			
4P	4P		4P			
690V	690V		690V			
690V	690V		1000V			
50/60Hz	50/60Hz		50/60Hz			
6kV	6kV		8kV			
1,800 operations per hour	1,800 operations per hour		1,800 operations per hour			
1500	1500		1200			
100	100		100			
40	50	60	80	100	110	135
15	18	22	30	37	41	51
40	50	60	80	100	110	135
27	35	42	56	70	76	95
40	50	60	80	100	110	135
35	43	52	70	88	97	120
40	50	60	80	100	110	135
44	55	66	88	110	120	150
40	50	60	80	100	110	135
32	45	50	70	80	90	100
2	2	3	3	5	5	7.5
3	5	5	7.5	10	15	15
7.5	7.5	10	10	15	20	25
7.5	10	10	15	20	25	30
10	20	25	30	40	50	50
15	20	25	30	40	50	50
0.4	0.59		1.2			
47.2×80×86.8	59×83.5×94.5		91×123.5×117.8			
0.5	0.7		1.29			
47.2×80×113.2	59×83.5×121		91×123.5×117.8			
-	-		-			
AU-1	AU-1		AU-1			
UA-2, UA-4	UA-2, UA-4		UA-2, UA-4			

Metasol Contactors



MC type Magnetic Contactors (4pole)

Frame size				225AF				
Type	Screw clamp terminal			MC-100a/4	MC-130a/4	MC-150a/4	MC-185a/4	MC-225a/4
Number of poles				●				
Rated operational voltage (Ue)				4P				
Rated insulation voltage (Ui)				690V				
Rated frequency				1000V				
Rated impulse withstand voltage, Uimp				50/60Hz				
Maximum operating rate in operating cycles per hour(AC3)				8kV				
Durability	Mechanical			1,200 operations per hour				
	Electrical			500				
Current and Power (IEC)	Thermal current		A	200	250	275	300	350
	AC-1	200/240V	kW	57	60	76	87	100
			A	200	250	275	300	350
		380/400V	kW	106	110	142	165	185
			A	200	250	275	300	350
		500/550V	kW	132	137	180	205	230
			A	200	250	275	300	350
UL rating (UL)	Continuous current	690V	kW	165	170	225	255	290
			A	200	250	275	300	350
	Single	110~120V	HP	200	250	275	300	350
		Phase	220~240V	HP	7.5	10	15	15
	Three	200~208V	HP	15	20	25	30	40
		Phase	220~240V	HP	30	40	40	60
	440~480V	HP	30	40	50	60	75	
	550~600V	HP	60	75	100	125	150	
Size and weight	AC	Weight	kg	60	75	100	125	150
		Control	Size(W×H×D)	5.6				
	DC	Weight	kg	175×203×185				
		Control	Size(W×H×D)	mm				
Auxiliary(standard)				2NO2NC				
Auxiliary	Side Mount			AU-100, AU-100E				
	Front Mount			-				

* - FLA = 722 A, LRA = 5618 A
 ** - FLA = 566 A, LRA = 4495 A



400AF

MC-265a/4	MC-330a/4	MC-400a/4
●		
4P		
690V		
1000V		
50/60Hz		
8kV		
1,200 operations per hour		
250		
50		
400	500	520
115	135	160
400	500	520
215	250	300
400	500	520
265	315	375
400	500	520
335	390	470
400	500	520
400	500	520
-	-	-
-	-	-
75	100	125
100	125	150
200	200	300
200	200	300

9.9
206×243×205

2NO2NC

AU-100, AU-100E
-

800AF

MC-500a/4	MC-630a/4	MC-800a/4
●		
4P		
690V		
1000V		
50/60Hz		
8kV		
1,200 operations per hour		
250		
50		
700	900	1050
245	255	310
700	900	1050
450	470	570
700	900	1050
560	590	710
700	900	1050
710	740	900
700	900	1050
700	900	1050
-	-	-
-	-	-
150	200	200
200	250	300
400	500	600 *
400	500	600 **

26.3
346×310 ×244

2NO2NC

AU-100, AU-100E
-

Metasol Contactors



Renewable Magnetic Contactor

- Eco-friendly contact material applied (Cd free)
- Type 2 coordination data with MCCB or ACB

Frame size			
Type	Screw clamp terminals		
Number of poles		pole	
Rated operational voltage (Ue)		Vac	
Rated insulation voltage (Ui)		Vac	
Rated frequency		Hz	
Rated impulse withstand voltage (Uimp)		kV	
Mechanical operating cycle		cycles/hour	
Electrical operating cycle		cycles/hour	
Durability	Mechanical	million	
	Electrical (AC-1@690V)	million	
	Electrical (AC-1@400V)	million	
Current and Power (IEC)	AC-1 1000V 55/60/70°C	A	
	Thermal current	A	
	Heat dissipation	W	
Rated Short-time withstand current(I _{cw}) (IEC 60947)	1s	A	
	10s	A	
	1min	A	
	10min	A	
max. breaking capacity (I _{cd})	400V	A	
	690V	A	
	1000V	A	
Type-2 Coordination (with MCCB or ACB)		kA	
Current and HP (UL)	Thermal current		
	Single phase	110~120V	HP
		220~240V	HP
	Three phase	200~208V	HP
		220~240V	HP
		440~480V	HP
550~600V		HP	
Weight (kg)			
Size (W×H×D)		mm	
Auxiliary(standard)			
Auxiliary	Side Mount		
	Front Mount		

1260AF			
	MCI-900	MCI-1050	MCI-1260
		●	
		3	
		1000	
		1000	
		50/60	
		8	
	600	600	300
	600	600	300
	100	100	50
	26	26	15
	50	50	20
	900/850/700	1050/875/720	1260/1060/900
	900	1050	1260
	100	170	170
	7000	7500	8000
	6400	7000	7200
	3500	3800	4000
	1550	1550	2300
	6000	7500	7500
	5000	7000	7000
	2000	2500	2500
	42kA (Break time: less than 20ms)		
	900	1050	1260
	-	-	-
	-	-	-
	200	200	-
	250	300	-
	500	600	-
	500	600	-
	22.2	22.2	25
	285×310×246	285×310×246	285×352×246
2NO2NC			
	AU-100, AU-100E (max.4NO4NC)		
	-		



2650AF		
MCI-1700	MCI-2100	MCI-2650
	●	
	3	
	1000	
	1000	
	50/60	
	8	
	300	
300	300	120
50	50	30
5	5	2
5	5	5
1700/1450/1300	2100/1750/1500	2650/2350/2150
1700	2100	2650
220	350	350
	12000	
	10000	
	5500	
	3000	
9000	12000	1200
8000	8500	8500
3000	3150	3150
42kA (Break time: less than 50ms)		
1700	2100	2650
-	-	-
-	-	-
-	-	-
-	-	-
-	-	-
34.6	34.6	47
431 × 380 × 246	431 × 380 × 246	431 × 392 × 246
2NO2NC		
AU-100, AU-100E (max.4NO4NC)		
-		

Metasol Contactors

Dimensions (18AF/22AF)

MC-6a-18a AC

1NO or 1NC

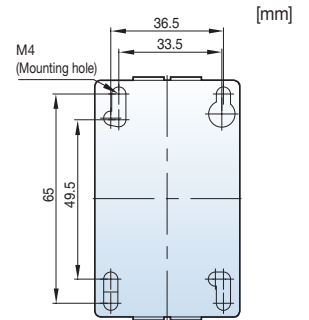
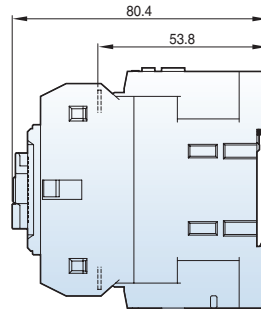
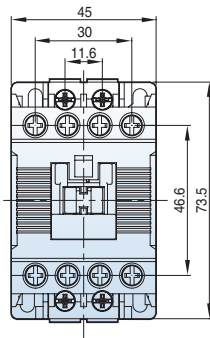

0.3kg

MC-6a-18a DC

1NO or 1NC

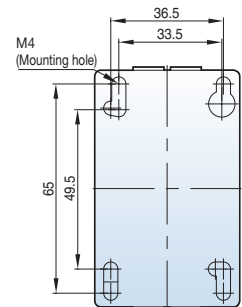
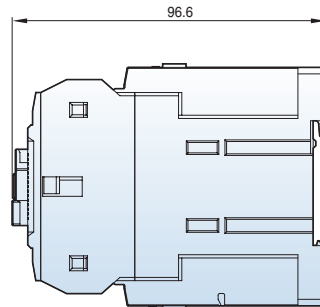
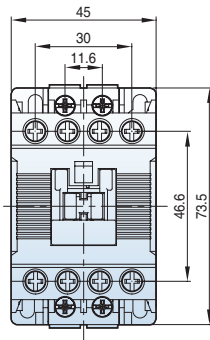

0.5kg

MC-9b-22b AC

1NO1NC

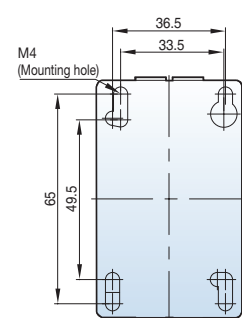
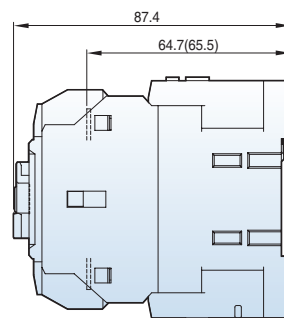
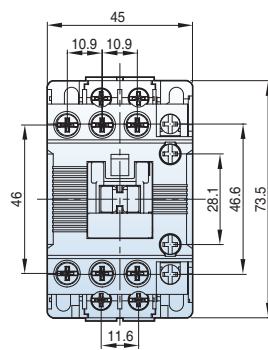

* () MC-18b, 22b

0.3kg

MC-9b-22b DC

1NO1NC

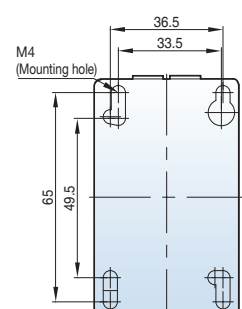
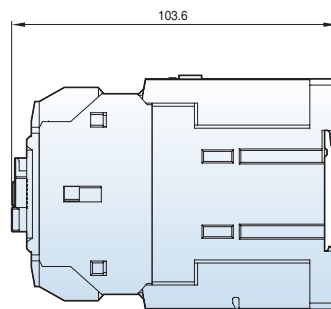
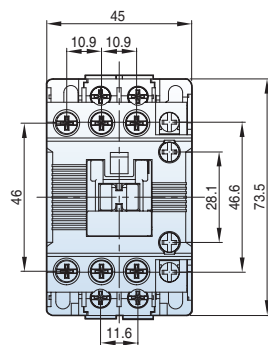

0.5kg

Dimensions (40AF/65AF)

MC-32a-40a AC
2NO2NC

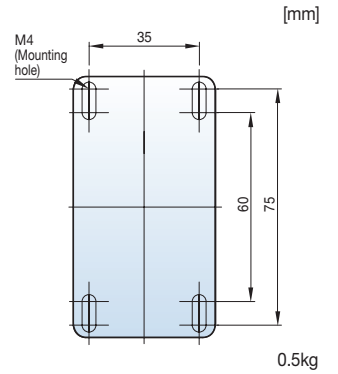
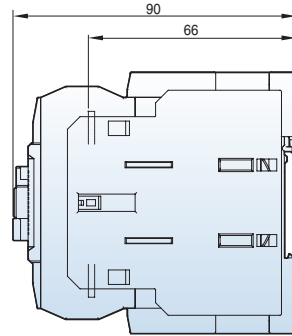
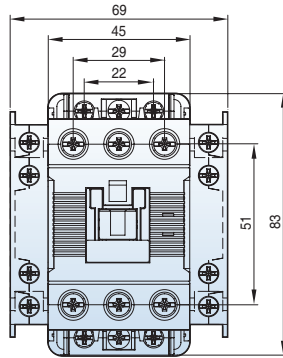

MC-32a-40a DC
2NO2NC

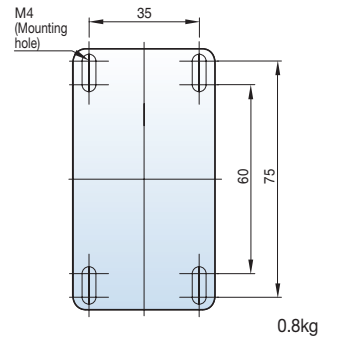
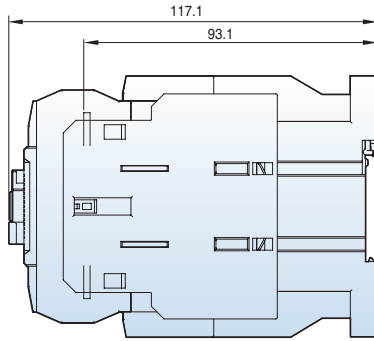
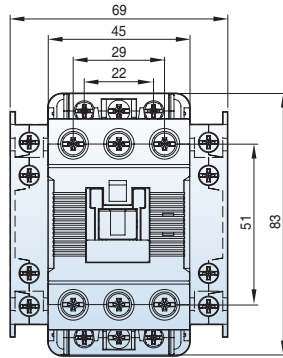

MC-50a-65a AC
2NO2NC

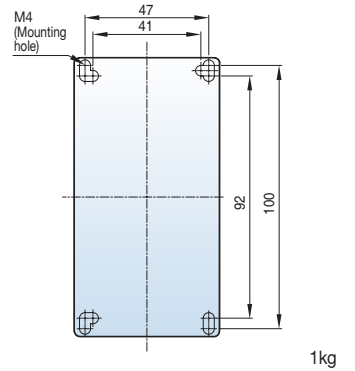
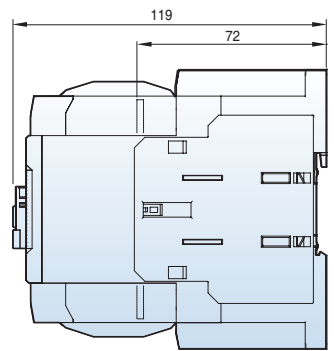
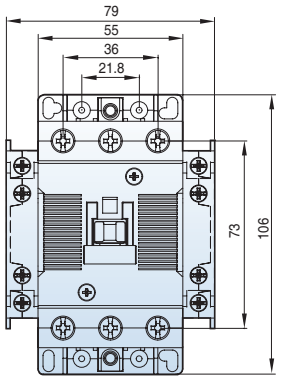

MC-50a-65a DC
2NO2NC

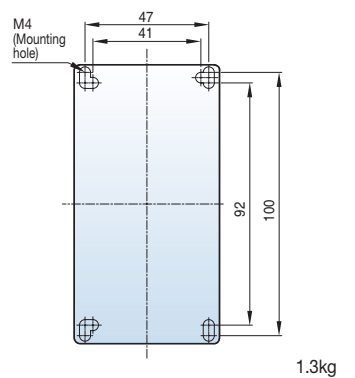
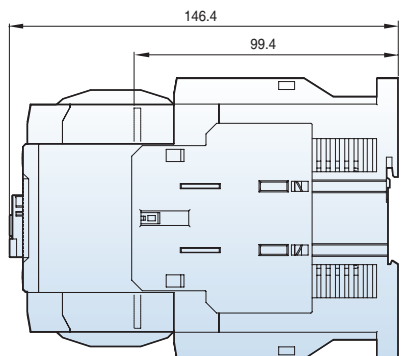
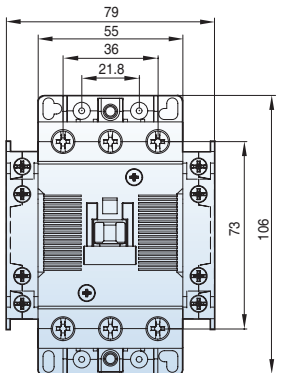

Metasol Contactors

Dimensions (100AF~400AF)

MC-75a~100a AC
2NO2NC

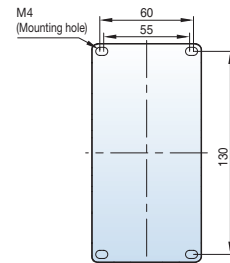
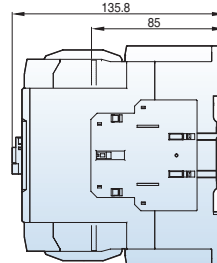
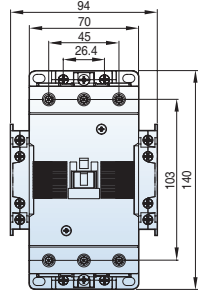

[mm]

1.9kg

MC-75a~100a DC
2NO2NC

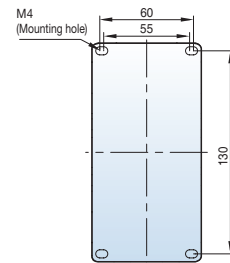
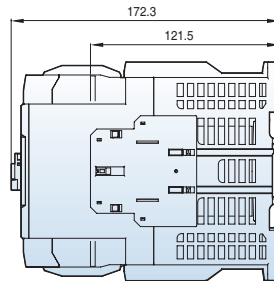
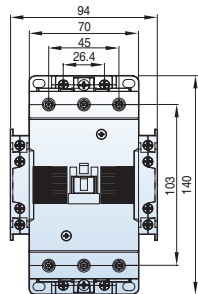

2.8kg

MC-130a
MC-150a

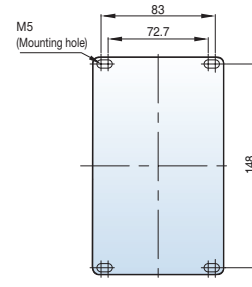
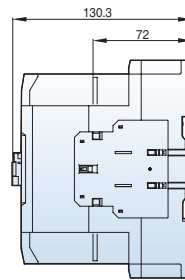
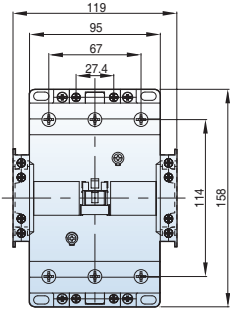

2.4kg

MC-185a
MC-225a

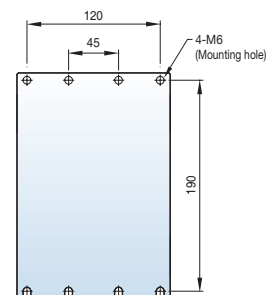
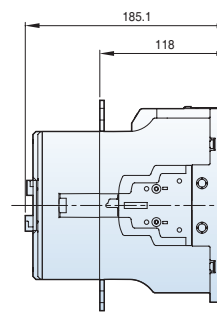
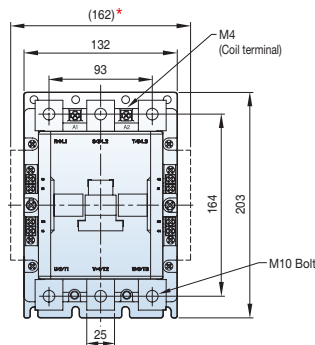

5.4kg

MC-265a
MC-330a
MC-400a

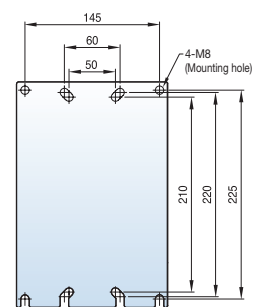
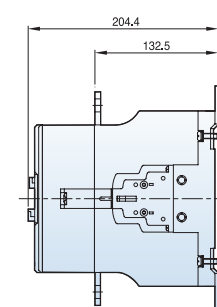
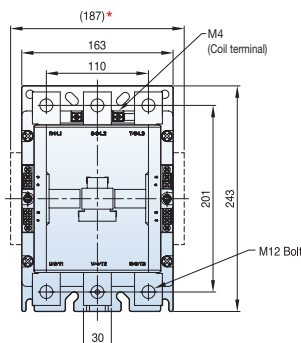

9.2kg

* Optional auxiliary contact unit (side mount type)

Dimensions (800AF~2650AF)

- MC-500a
- MC-630a
- MC-800a
- MCi-900
- MCi-1050

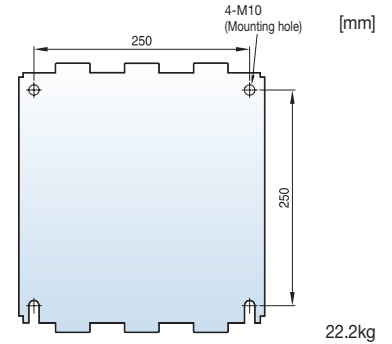
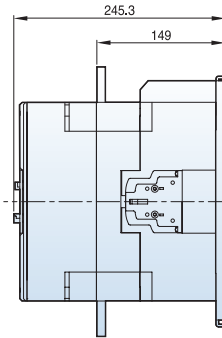
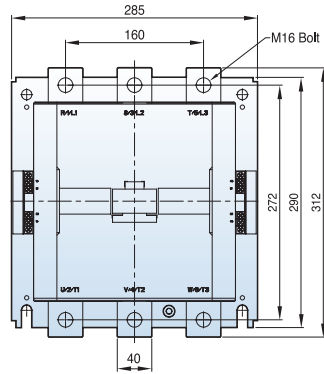

22.2kg

- MC-1260a
- MCi-1260

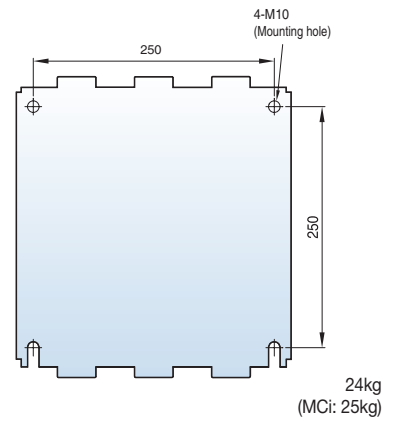
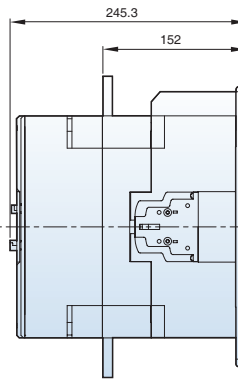
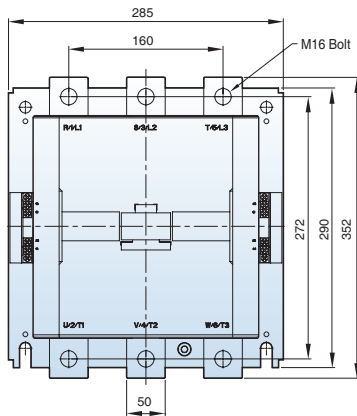

24kg
(MCi: 25kg)

- MC-1400a
- MC-1700a
- MC-2100a
- MCi-1700
- MCi-2100

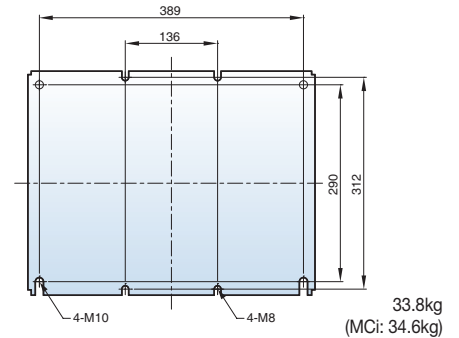
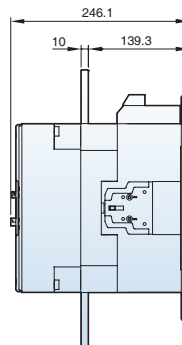
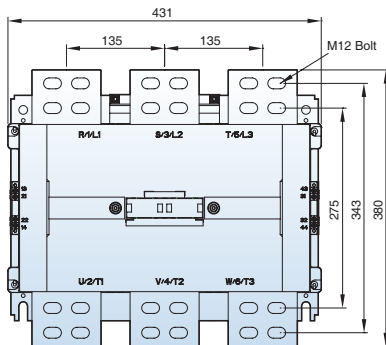

33.8kg
(MCi: 34.6kg)

- MC-2650a
- MCi-2650

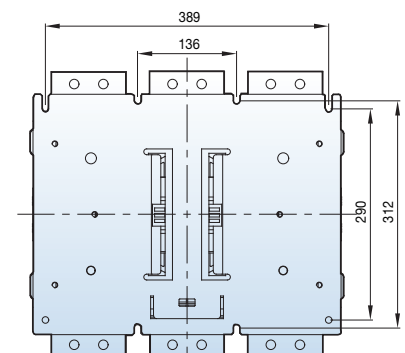
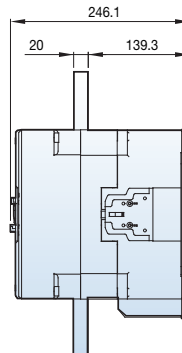
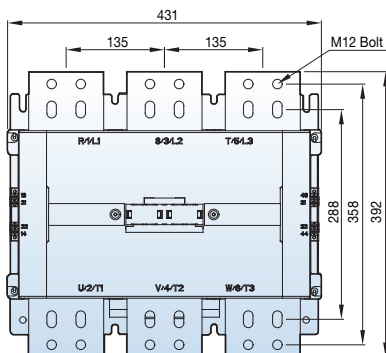

47kg

Metasol Contactors

Dimensions (MC-6a/4~22a/4)

MC-6a/4~18a/4 AC

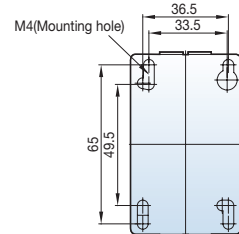
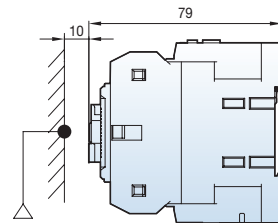
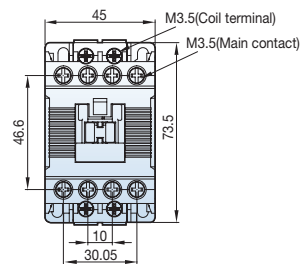

[mm]

0.3kg

MC-6a/4~18a/4 DC

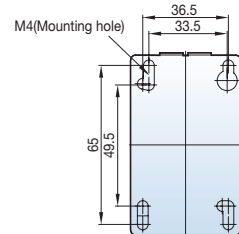
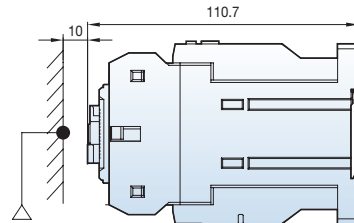
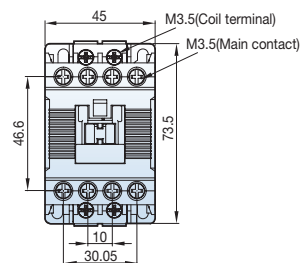

0.45kg

MC-22a/4 AC

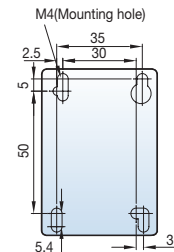
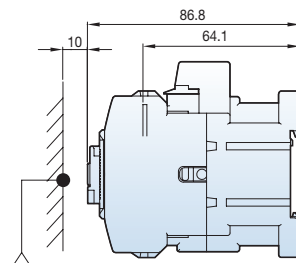
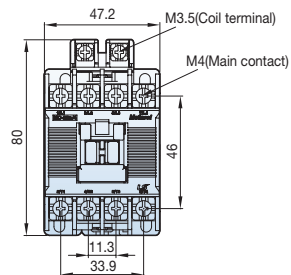

0.4kg

MC-22a/4 DC

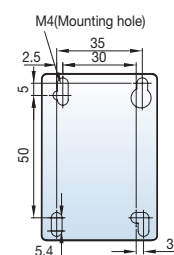
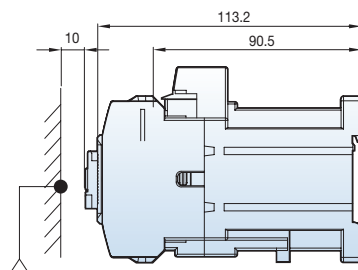
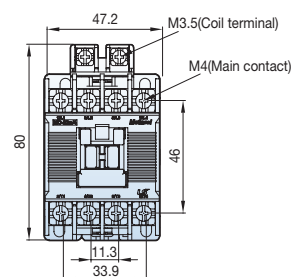

0.5kg

Dimensions (MC-32a/4~85a/4)

MC-32a/4~40a/4 AC

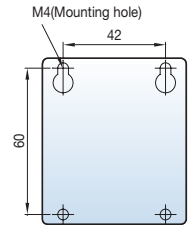
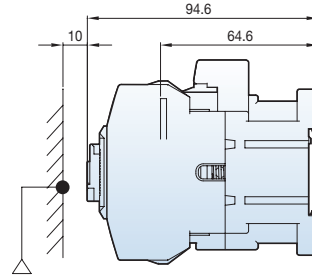
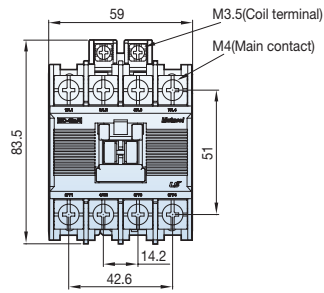

[mm]

0.59kg

MC-32a/4~40a/4 DC

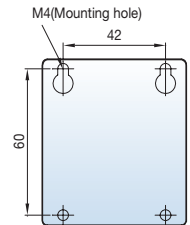
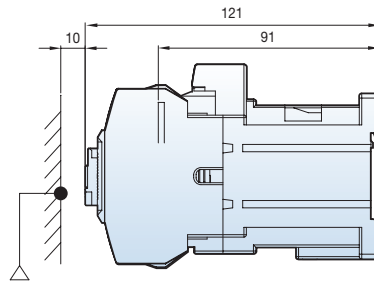
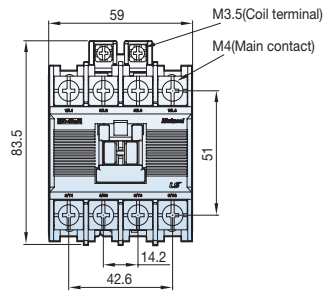

0.7kg

MC-50a/4~85a/4 AC

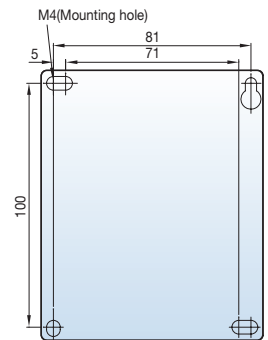
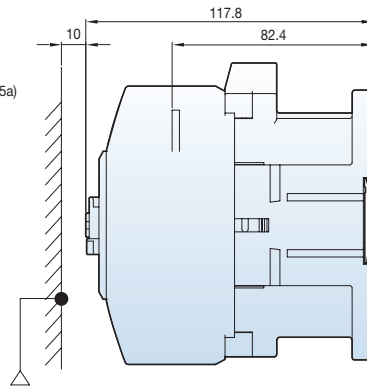
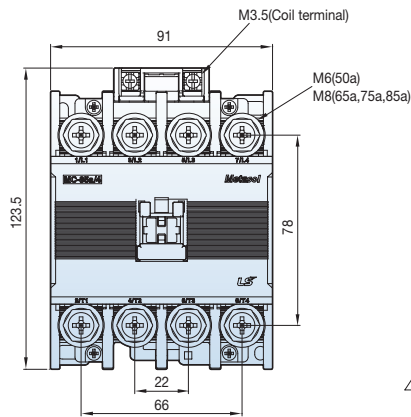

1.2kg

MC-50a/4~85a/4 DC

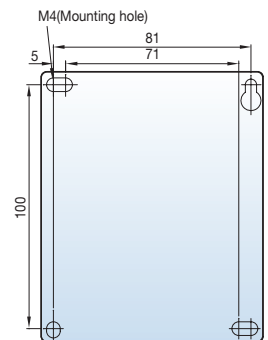
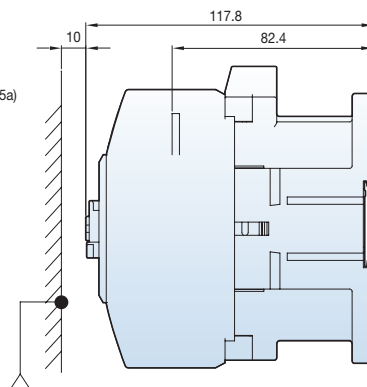
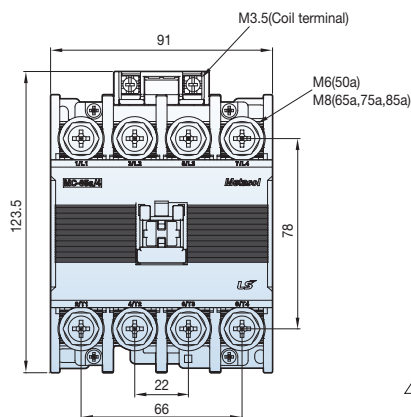

Metasol Contactors

Dimensions (MC-100a/4~800a/4)

[mm]

- MC-100a/4
- MC-130a/4
- MC-150a/4
- MC-185a/4
- MC-225a/4

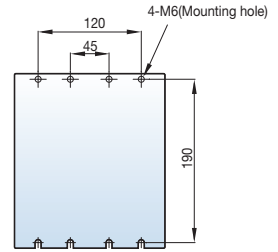
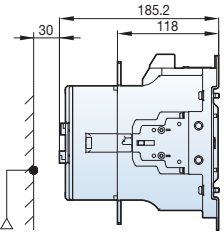
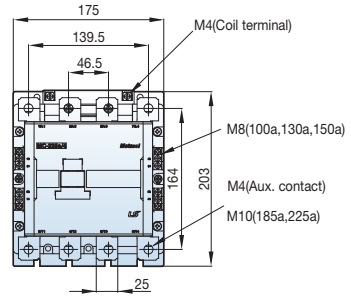

5.6kg

- MC-265a/4
- MC-330a/4
- MC-400a/4

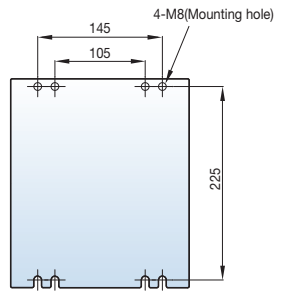
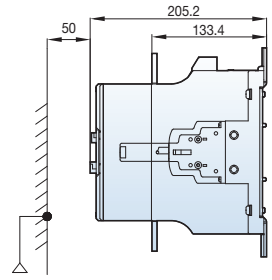
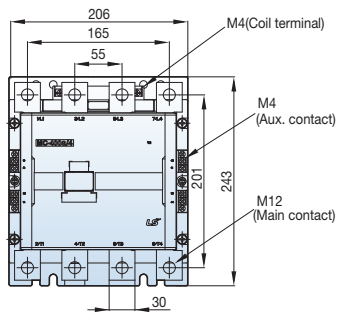

9.9kg

- MC-500a/4
- MC-630a/4
- MC-800a/4

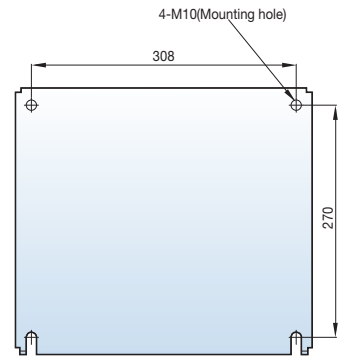
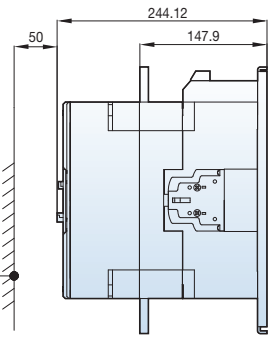
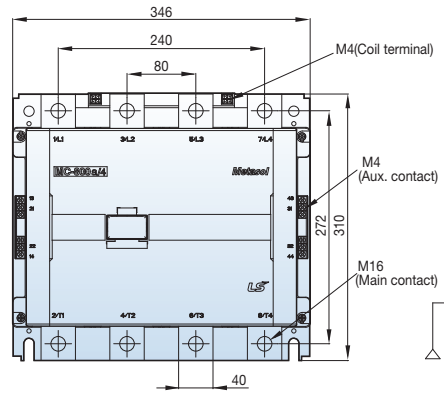

26.3kg

Susol Busways

Characteristics

- AC 1000V or less/DC 1500V or less, 50/60Hz, Al/Cu conductor
- Compact enclosure minimizes footprint.
- Sealed Enclosure: Protection class IP54 (Indoor)/65 (Outdoor)
- High reliability with short-circuit strength and fire resistance
- Eco-friendly lightweight product with batch extrusion insulation coating and aluminum alloy material
- Easy installation and maintenance through joint pack assembly
- Up to 7,500A current capacity (Cu type) ensuring large capacity of power supply
- Al-Al Type, Total capacity (A) KS certification and ASTA certificate



Rating

Item	Rating		
Rated voltage	AC1000V/DC1500V		
Rated current	Al	630 ~ 6000A	
	Cu	630 ~ 7500A	
Rated frequency	50/60Hz		
Short-time withstand current	Al	2000A	121kA/1sec
		4000A	200kA/1sec
	Cu	2000A	135kA/1sec
		4000A	220kA/1sec
Wiring system	3W, 4W, 5W		
Grounding	Basic method	Grounding to housing	
	Maximum capacity	Over 200%	
	Grounding type	Housing : over 100%	
Internal Type : 50/100 %			
Resistance to fire, optional	AC 1000V : 840°C / 180min.		
Degree of protection	Indoor	IP54	
	Outdoor	IP65	
Enclosure material	High Strength Aluminum Extrusion (Thickness : 3mm)		
Insulation material	Insulation Coating : Polyvinyl Chloride Insulation Spacer : Lexan Resin		
Conductor material	Aluminum or Copper		
Environment	Altitude	Below 1000m	
	Ambient temp	Max. 40 , min. -5 (min. -25 for Outdoor Type)	
	Humidity	Below 95%	
Allowable temp. (IEC standard)	Housing	55K	
	Joint part	95K	
Color of painting	MUNSELL No.	5Y 7/1	
		7.5 BG 6/1.5	
Standard	IEC 60439 - 1, 2		

Susol Busways

Application

Building distribution system

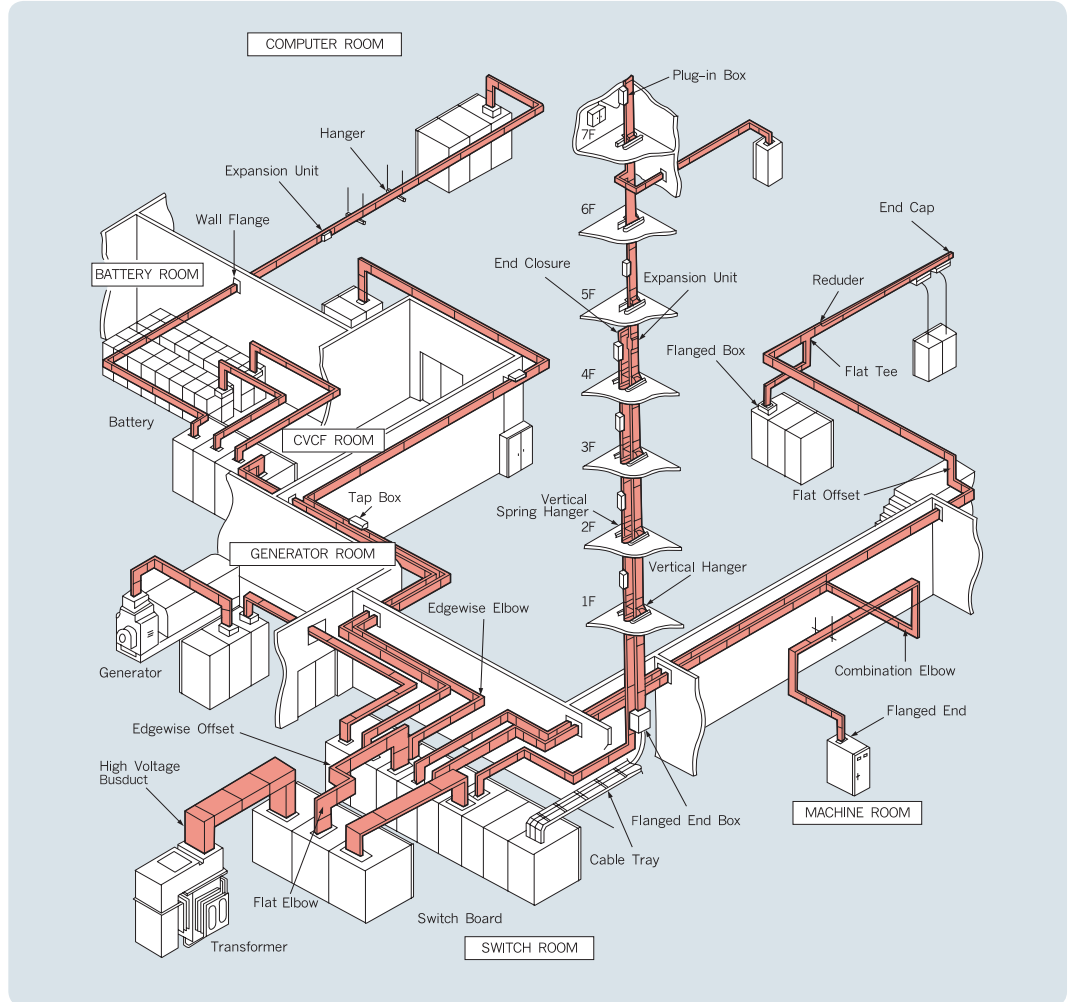

Plant distribution system

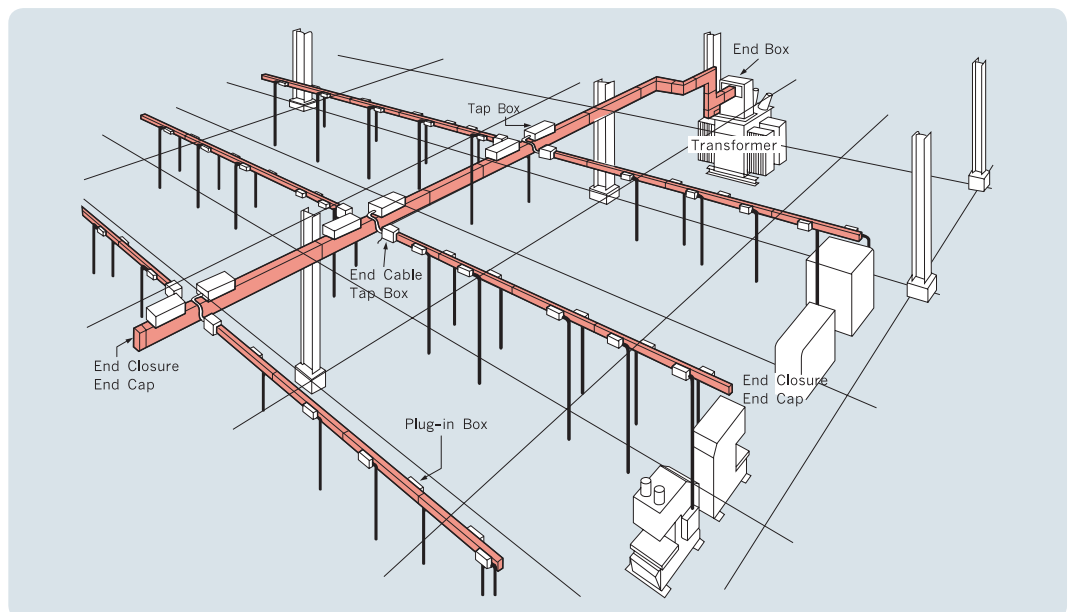

Cross section and dimensions (Indoor type)

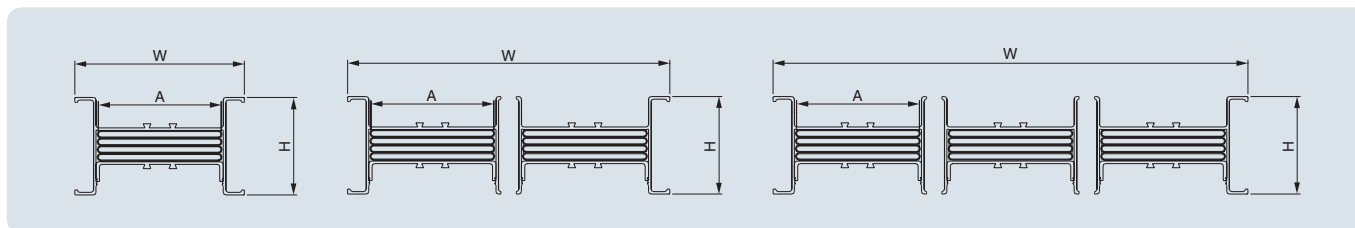

<Fig.1>

<Fig.2>

<Fig.3>

Aluminum Conductor

Rated current (A)	Fig.	Al Busbar		3W				4W				5W			
		T (mm)	A (mm)	W (mm)	H (mm)	Weight(kg/m)		W (mm)	H (mm)	Weight(kg/m)		W (mm)	H (mm)	Weight(kg/m)	
						3W	50%E			4W	50%E			5W	50%E
630	Fig.1	6,35	41	96	106	6	6.4	96	115	6.5	7	96	124	7.7	8.1
800			62	117		7.5	8	117		9	9.5	117		10.1	10.6
1000			86	141		8.5	9	141		10.5	11	141		12.5	13.2
1250			108	163		10	11	163		12	13	163		14.8	15.6
1600			164	219		14	15.5	219		17	18.5	219		20.5	21.7
2000	Fig.2	6,35	210	265	106	17	18.5	265	115	21	22.5	265	124	25.1	26.8
2500			126 × 2	342		23	25	342		27.5	29.5	342		32.5	34.4
3200			164 × 2	418		28.5	31	418		34	36.5	418		40.2	42.8
3600			184 × 2	458		31	34	458		37.5	40.5	458		44.2	47.1
4000			210 × 2	510		35	38.5	510		42	45.5	510		49.6	52.8
5000	Fig.3	6,35	184 × 3	677	106	46.5	50.5	677	115	56.5	60.5	677	124	65.9	70.2
6000			210 × 3	755		51.5	56.5	755		63	67.5	755		74.0	78.9

Copper Conductor

Rated current (A)	Fig.	Al Busbar		3W				4W				5W			
		T (mm)	A (mm)	W (mm)	H (mm)	Weight(kg/m)		W (mm)	H (mm)	Weight(kg/m)		W (mm)	H (mm)	Weight(kg/m)	
						3W	50%E			4W	50%E			5W	50%E
630	Fig.1	6,35	41	96	106	10.5	11.5	96	115	13	14	96	124	15.6	16.7
800			41	96		10.5	11.5	96		13	14	96		15.6	16.7
1000			57	112		13.5	15	112		17	18.5	112		20.7	22.1
1250			73	128		16.5	18.5	128		20.5	22.5	128		25.6	27.4
1600			108	163		23	26	163		29	32	163		36.3	39.1
2000	Fig.2	6,35	145	200	106	30	33.5	200	115	38.5	42	200	124	47.6	51.4
2500			195	250		39	44.5	250		50	55.5	250		62.9	68.0
3200			108 × 2	306		46	52	306		58.5	64.5	306		72.0	77.5
3600			126 × 2	342		52.5	59.5	342		67	74	342		83.0	89.5
4000			145 × 2	380		60	67	380		77.5	84.5	380		94.6	102.1
5000	Fig.3	6,35	195 × 2	480	106	78	88.5	480	115	101	111.5	480	124	125.2	135.3
6000			145 × 3	560		89.5	100.5	560		115.5	126.5	560		141.1	152.3
7500			195 × 3	710		117	133.5	710		151	167.5	710		187.0	202.2

Note) 5W is applied to the structure of 4W+100%E and 3P+N200%

Susol Busways

Cross section and dimensions (Outdoor type)

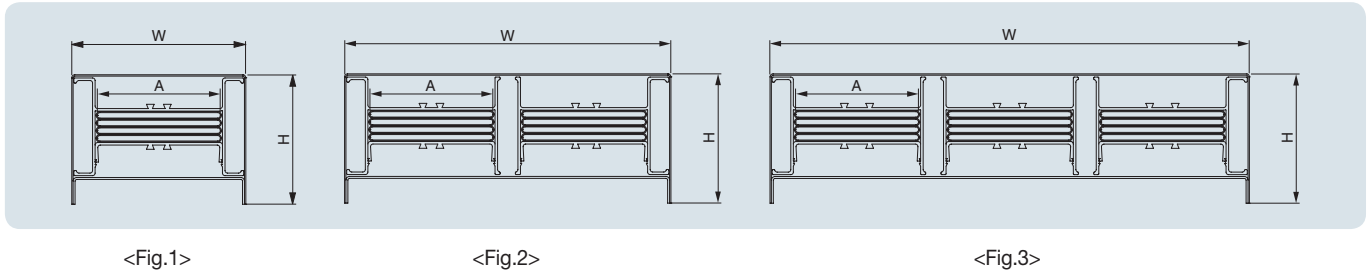

Aluminum Conductor

Rated current (A)	Fig.	Al Busbar		3W				4W				5W			
		T (mm)	A (mm)	W (mm)	H (mm)	Weight(kg/m)		W (mm)	H (mm)	Weight(kg/m)		W (mm)	H (mm)	Weight(kg/m)	
						3W	50%E			4W	50%E			5W	50%E
630	Fig.1	6.35	41	101	143.5	7.3	7.6	101	152.5	8.2	8.5	101	161.5	9.1	9.5
800			62	122		9.0	9.5	122		10.3	10.8	122		11.5	12.0
1000			86	146		10.7	11.4	146		12.3	13.0	146		14.0	14.7
1250			108	169		12.3	13.1	169		14.3	15.1	169		16.4	17.2
1600			164	224		16.2	17.5	224		19.2	20.5	224		22.3	23.5
2000	Fig.2	210	270	143.5	19.5	21.1	270	152.5	23.2	24.9	270	161.5	27.0	28.7	
2500		126 × 2	347		25.3	27.2	347		30.0	31.9	347		34.6	36.5	
3200		164 × 2	423		30.7	33.3	423		36.6	39.2	423		42.6	45.2	
3600		184 × 2	463		33.5	36.4	463		40.2	43.1	463		46.7	49.6	
4000	Fig.3	210 × 2	515	143.5	37.3	40.5	515	152.5	44.7	48.0	515	161.5	52.3	55.5	
5000		184 × 3	682		19.4	53.8	682		60.1	63.7	682		69.1	73.4	
6000		210 × 3	760		55.0	59.9	760		66.2	71.1	760		77.5	82.4	

Copper Conductor

Rated current (A)	Fig.	Al Busbar		3W				4W				5W			
		T (mm)	A (mm)	W (mm)	H (mm)	Weight(kg/m)		W (mm)	H (mm)	Weight(kg/m)		W (mm)	H (mm)	Weight(kg/m)	
						3W	50%E			4W	50%E			5W	50%E
630	Fig.1	6.35	41	101	143.5	12.1	13.1	101	152.5	14.6	15.5	101	161.5	17.0	18.1
800			41	101		12.1	13.1	101		14.6	15.5	101		17.0	18.1
1000			57	117		15.3	16.8	117		18.8	20.1	117		22.1	23.5
1250			73	133		18.3	20.2	133		22.7	24.5	133		27.1	28.9
1600			108	168		25.0	27.8	168		31.2	34.2	168		37.9	40.7
2000	Fig.2	145	205	143.5	32.0	35.7	205	152.5	40.3	44.5	205	161.5	49.3	53.1	
2500		195	255		14.3	46.4	255		52.6	58.3	255		64.8	69.9	
3200		108 × 2	311		48.2	53.7	311		61.3	66.8	311		74.0	79.5	
3600		126 × 2	347		54.9	61.5	347		70.3	76.8	347		85.1	91.6	
4000	Fig.3	145 × 2	385	143.5	62.2	69.7	385	152.5	79.9	87.3	385	161.5	96.9	104.4	
5000		195 × 2	485		81.0	91.1	485		105.0	115.0	485		127.8	137.9	
6000		145 × 3	565		92.3	103.5	565		118.5	129.7	565		143.9	155.1	
7500	195 × 3	715	120.7	135.8	715	156.2	171.3	715	190.3	205.5					

Note) 5W is applied to the structure of 4W+100%E and 3P+N200%

XGIPAM

Characteristics

- Protective use model (F, B, M, T, DG)
- 8.4 inches of color Touch Screen
- Performing 0.2% measurement accuracy for Current and Voltage
- Sag, Swell, Interruption & Harmonic analysis of 1~63rd orders
- Increasing reliability/Flexibility through Duplex communication



Type of Protection

Type	Vsage	Protection
XGIPAM - F	Feeder/Incomming	OCR(50/51), OCGR(50/51N), UVR(27), OVR(59), SGR(67G), DGR(67N) ^{Note)} , OVGR(64I/D), NSOVR(47N), POR(47), SYNC Check(25), Reclosing(79), Temperature(38)
XGIPAM - B	Bay controller	OCR(50/51), OCGR(50/51N), UVR(27), OVR(59), SGR(67G), DGR(67N) ^{Note)} , OVGR(64I/D), NSOVR(47N), POR(47), SYNC Check(25), Reclosing(79), Temperature(38), DOCR(67I/D), NSOCR(46I/D), UFR(81U), OFR(81O), DPR(32P), DQR(32Q)
XGIPAM - M	Motor	OCR(50/51), OCGR(50/51N), UVR(27), OVR(59), SGR(67G), DGR(67N) ^{Note)} , OVGR(64I/D), NSOVR(47N), POR(47), Temperature(38), Stall/Locked Rotor(48/51LR), THR(49), DOCR(67I/D), UCR(37), NCH(66), NSOCR(46I/D)
XGIPAM - T	Transformer	OCR(50/51)×2, OCGR(50/51N), UVR(27), OVR(59), Temperature(38), DPR(32P), DFR(87T)
XGIPAM - DG	Distributed Generator	OCR(50/51), OCGR(50/51N), UVR(27), OVR(59), DPR(32P), UPR(37P), DQR(32Q), UFR(81U), OFR(81O), DGR(67N) ^{Note)} , SYNC Check(25), DOCR(67I/D), NSOCR(46I/D), POR(47), NSOVR(47N), ROCOF(81R), SGR(67G), OVGR(64I/D)
XGIPAM - 3wT	Transformer (3권선)	OCR(50/51)×3, OCGR(50N/51N), UVR(27), OVR(59), OVGR(64I/D), DFR(3W87T)

Note) DGR is the same as DOGR.

Ratings

Type	Specification		
Wiring	3P3W, 3P4W		
Input	Frequency	60Hz (50Hz *)	
	Voltage	PT: 100/√3, 110/√3, 120/√3, 190/√3, 100, 110, 120V GPT: 100~190V	
	Current	CT: 5A, ZCT: 1.5mA	
	Power consumption	Normal: Max. 30W, Operating: Max. 70W	
	Control voltage	AC 110V, DC 110~125V	
	Burden	PT: Max. 0.5VA (Phase PT Standard), CT: Max. 1.0VA Input contact Digital Input, AC/DC 110V	
Output contact	TRIP	Rated	AC 250V 10A / DC 30V 10A, Resistive Load
		Open	AC 2500VA, DC 300W
	ALARM	Close	AC 250V 5A / DC 30V 5A, Resistive Load
		Open	AC 1250VA, DC 150W
Insulation Resistance	Over DC 500V 10MΩ		
Dielectric Strength	Electric circuits to Earth : AC 2kV(1kV) / for 1 min Between electric circuits : AC 2kV(1kV) / for 1 min Between terminals of contact circuit: AC 1kV(1kV) / for 1 min		
Overload withstand	Current circuit	3 In for 3 hours, 20 In for 2 seconde	
	Voltage circuit	1.15Vn for 3 hours	
Fast Transient Disturbance	Power Input 4kV, Other Input 2kV		
Electrostatic Discharge(ESD)	Air 8kV, Contact 6kV		
Operation temperature	-10°C ~ 55°C		
Storage temperature	-25°C ~ 70°C		
Humidity	30% ~ 80%		
Height above sea level	1500m or less		
Others	Non-impact place, Non-air pollution place		
Weight	7kg (HMI: 2kg)		

* Please contact the sales department for 50Hz in parentheses.

XGIPAM

XGIPAM - F Characteristics

Protection	Operating part	Setting range	Operating characteristics	Operating time	Delay time	Remarks
OCR (50)	Stage 1	OFF, 0.10~32.00In/0.01In	Instantaneous Definite	30msec and below 0.050~300.000s/0.001s	-	-
	Stage 2					
OCR (51)	Stage 1	OFF, 0.02~10.00In/0.01In	Definite Inverse	0.050~300.000s/0.001s 0.05~1.2/0.01	-	IEC SI/VI/EI/LI ANSI SI/VI/LI KEPCO SI/VI
	Stage 2					
OCGR (50N)	Stage 1	OFF, 0.1~32.00In/0.01In	Instantaneous Definite	30msec and below 0.050~300.000s/0.001s	-	-
	Stage 2					
OCGR (51N)	Stage 1	OFF, 0.02~10.00In/0.01In	Definite Inverse	0.050~300.000s/0.001s 0.05~1.2/0.01	-	IEC SI/VI/EI/LI ANSI SI/VI/LI KEPCO SI/VI
	Stage 2					
SGR (67G)	Stage 1	OFF, 0.6~6.0mA/0.1mA Vo: 0V, 8V~80V/1V Characteristics angle: 0~±90°/1°	Definite	0.050~10.000s/0.001s	-	-
	Stage 2					
DGR (67N)	Stage 1	OFF, 0.02~10.00In/0.01In Vo: 8~80V/1V Characteristics angle: 0~±90°/1° Operating range: 60~87°/1°	Instantaneous Definite Inverse	50msec and below 0.050~300.000s/0.001s 0.05~1.20/0.01	-	IEC SI/VI/EI/LI ANSI SI/VI/LI KEPCO SI/VI
	Stage 2					
UVR (27)	Stage 1	OFF, 0.10~1.10Vn/0.01Vn Auto Reset: Enable/Disable	Definite	0.050~300.000s/0.001s	-	Dead Voltage Block: 0.05Vn
	Stage 2					
OVR (59)	Stage 1	OFF, 0.80~1.60Vn/0.01	Definite Inverse	0.050~300.000s/0.001s 0.01~1.20/0.01	-	IEC SI/VI/EI/LI ANSI SI/VI/EI
	Stage 2					
OVGR (64)	Stage 1	OFF, 5~80V/1V	Instantaneous Definite	30msec and below 0.050~300.000s/0.001s	-	-
	Stage 2					
OVGR (64D)	Stage 1	OFF, 5~80V/1V	Definite Inverse	0.050~300.000s/0.001s 0.05~1.20/0.01	-	IEC SI/VI/EI/LI ANSI SI/VI/EI
	Stage 2					
NSOVR (47N)	Stage 1	OFF, 11~120V/1V	Definite	0.050~300.000s/0.001s	-	-
	Stage 2					
POR (47)	Stage 1	OFF, 2.0~100%/1%	Definite	0.050~300.000s/0.001s	-	-
	Stage 2					
Synchro-check (25)	Stage 1	V Diff: OFF, 2~50V/1V Phase Diff: OFF, 5~45/1° F Diff: 0.01~0.50/0.01Hz Dead V: 0.2~0.4Vn/0.01Vn	-	After the synchronous Conditions are satisfied, it operate within 1sec.	-	Synchronous allowable voltage 0.5Vn~1.2Vn
Temperature (38)	Stage 1	OFF, 20~180°C/1°C	Definite	0.050~300.000s/0.001s	-	Range setting required for stage 2 on AI set to relay
	Stage 2					
Reclosing (79)	Stage 1	Reclosing counts: 1 ~ 5 times • Prepare Timer : 0.020 s ~ 60.000 s (0.001 s) • Dead Timer : 5, 0.060 s ~ 300.000 s (0.001 s) • CB Operation Timer : 0.05 s ~ 0.500 s (0.001s) • Reclaim Time : 1.000 s ~ 300.000 s (0.001s) • Scheme : Dead Bus-Dead Line, Dead Bus-Live Line, Live Bus-Dead Line, Live Bus-Live Line • Dead: 0 ~ 0.1Vn • Live: 0.5Vn ~				

* When the relay element OVGR (64) is operated instantaneously using VectorSum (vector sum, Vo), its operation time will be within 50msec.

XGIPAM - F/B/M/DG (3P3W) Wiring

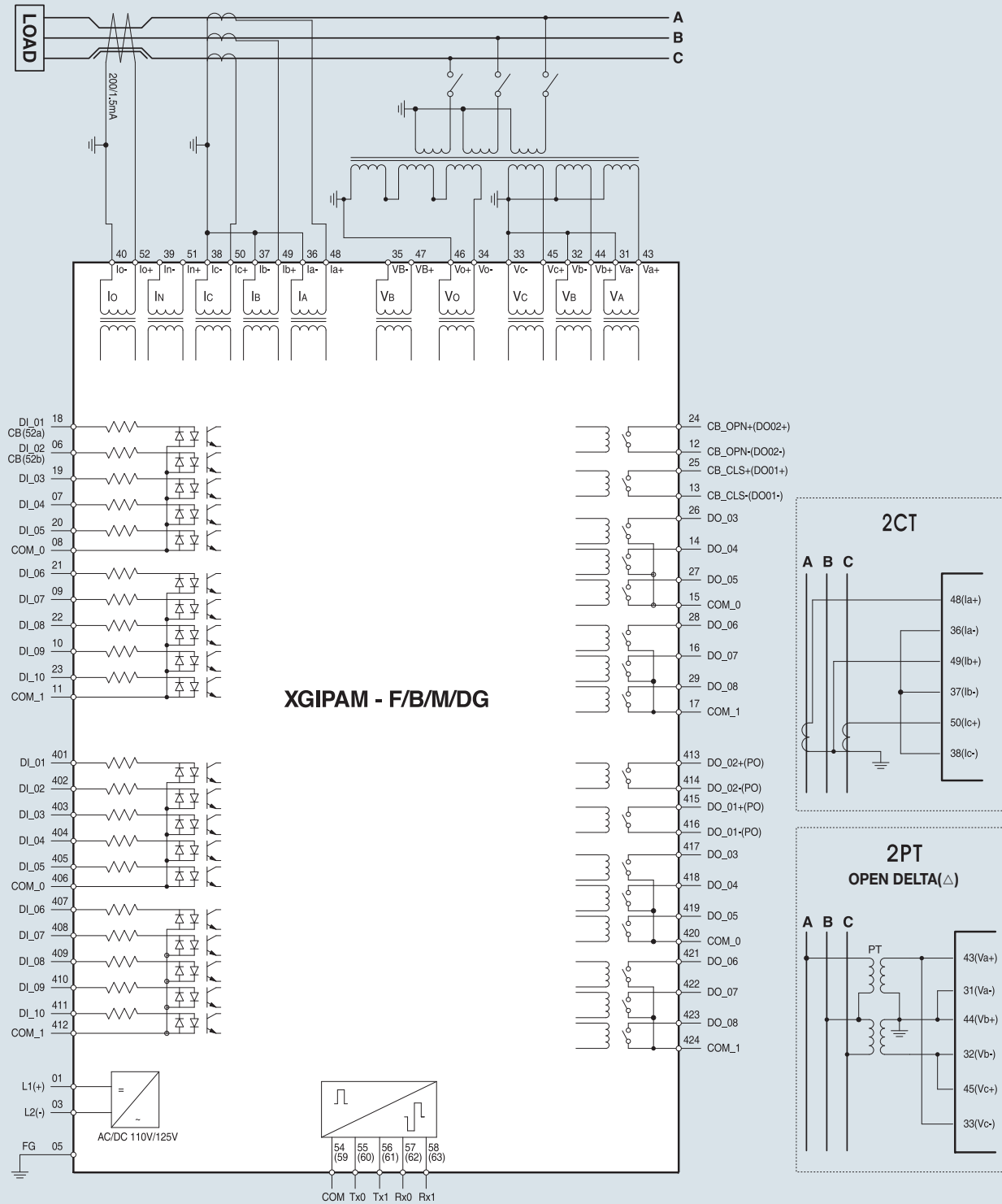

XGIPAM - F/B/M/DG

* For example is Number 413 described 13 in slot #4

XGIPAM

with integrated HMI)

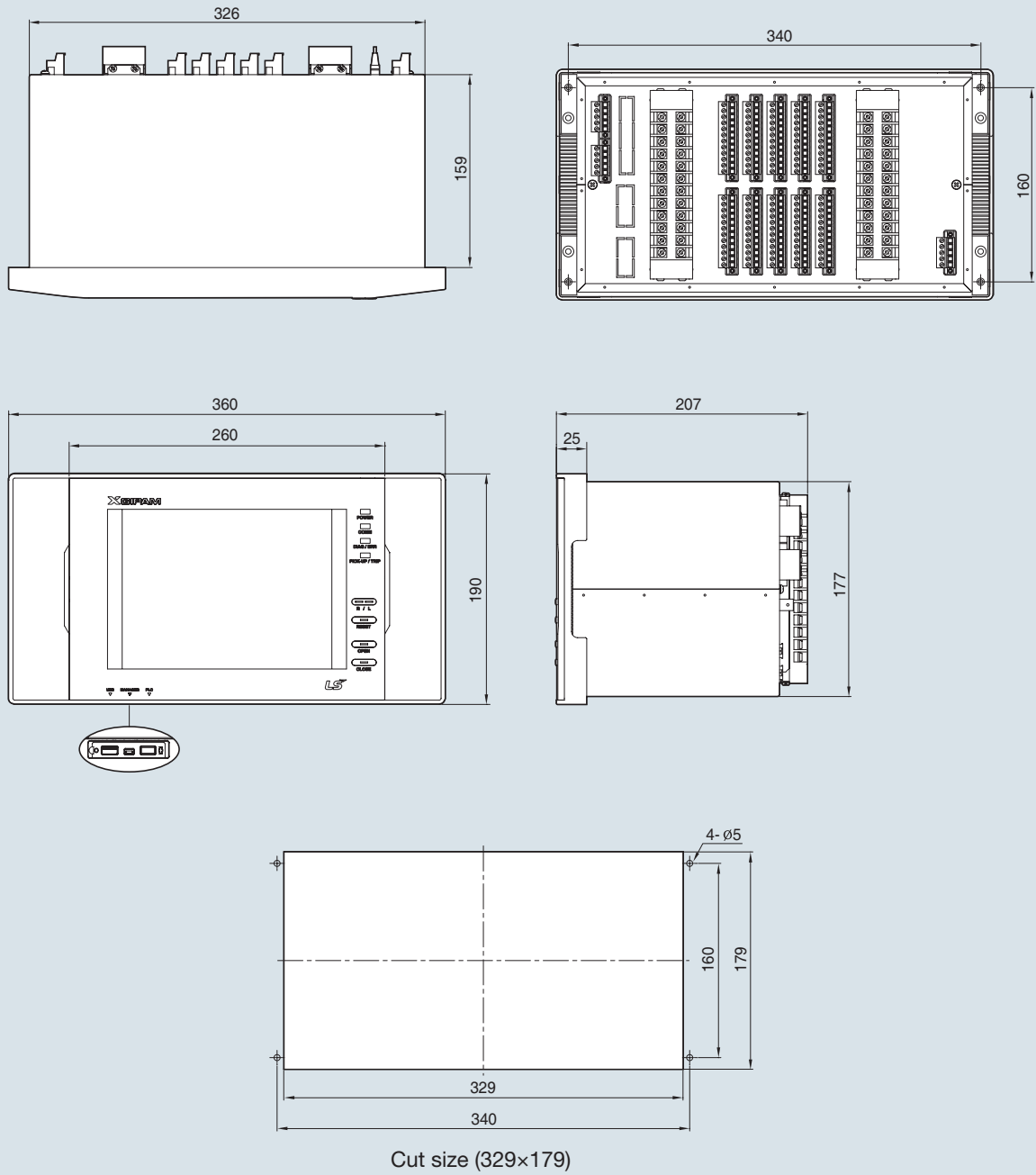

Susol RMU

Characteristics

- Applicable to renewable electricity generation (wind, solar)
- Configurable TR Container Pack



Susol RMU

Ratings

Rated voltage	kV	12	17.5	24	36
Rated frequency	Hz	50 / 60	50 / 60	50 / 60	50 / 60
Rated power frequency withstand voltage	kV	28	38	50	70
Rated power frequency withstand voltage	kV	75	95	125	170
Rated current main busbars	A	630	630	630	630
Rated short-time withstand current (3s)	kA	21	21	21	20
Rated short-circuit making current	kA	54.6	54.6	54.6	52
Internal arc fault current (1s, AFAL)	kA	21	21	21	20
Rated SF ₆ gas pressure	Psi.G	5	5	5	5

Applicable type



24kV LFL type



24kV LCL type



24kV Extensible type



36kV LCL type

Susol RMU

12/17.5/24kV CB Feeder Non-Extensible RMU

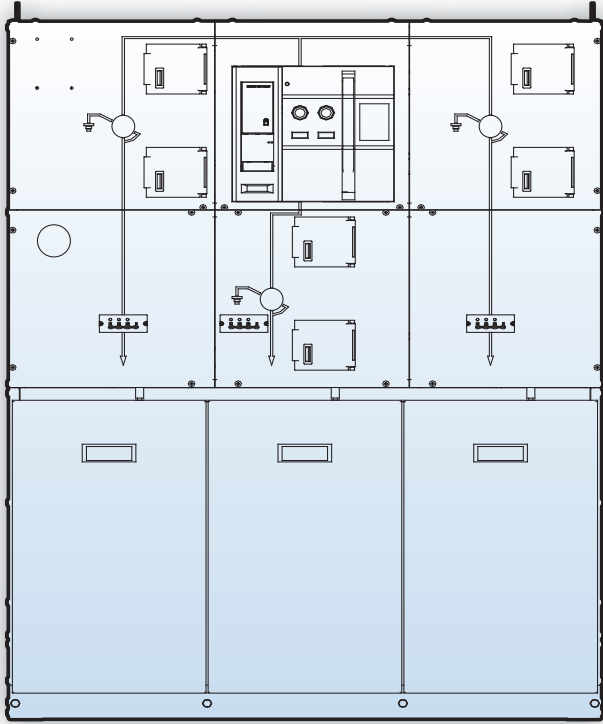

- Consists of two circuit LBS and one circuit CB-DS in a single chamber
- Protects equipment using Circuit Breaker
- Complete Sealing System
- Increases durability through S/S application
- L: Load break switch
- C: Vacuum circuit breaker

Applicable type

[W×H×D, mm]

RC (1R1C)

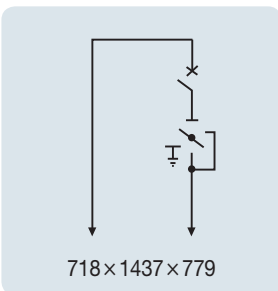

LC (1L1C)

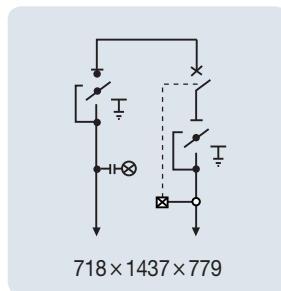

LCL (2L1C)

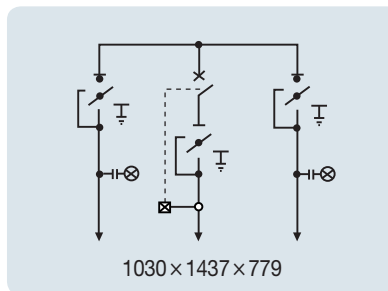

LLCL (3L1C)

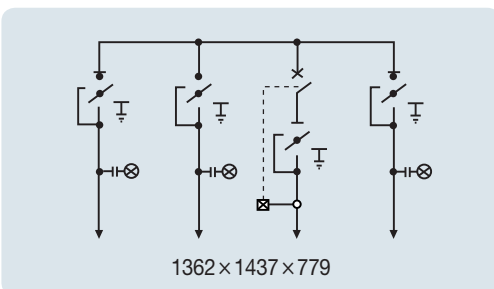

LCCL (2L2C)

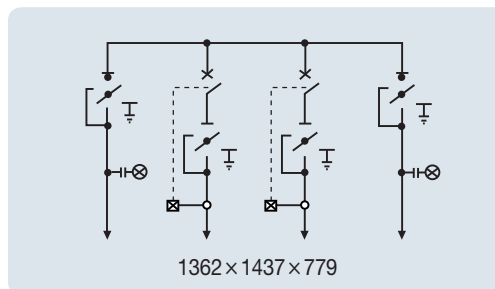

36kV CB Feeder Non-Extensible RMU

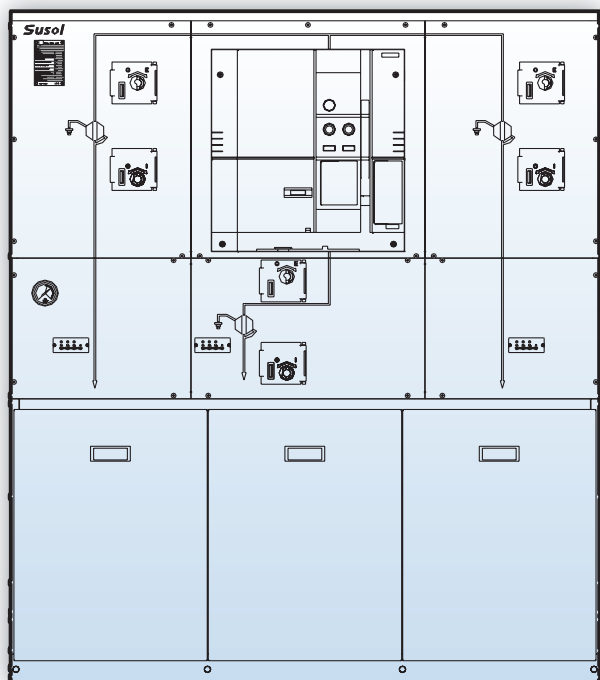

- Consists of two circuit LBS and one circuit Switch-Fuse in a single chamber
- Protects equipment using Switch Fuse
- Complete Sealing System
- Application of high grade OCR
- Increase durability through S/S application
- L: Load break switch
- C: Vacuum circuit breaker

Applicable type

[W×H×D, mm]

RC (1R1C)

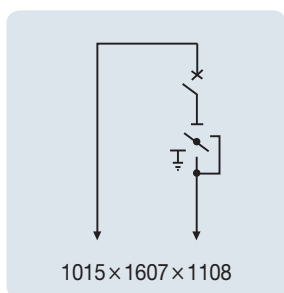

LC (1L1C)

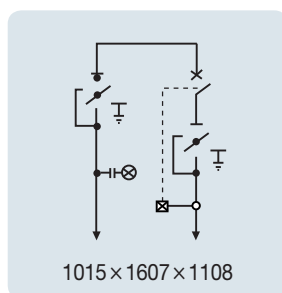

LCL (2L1C)

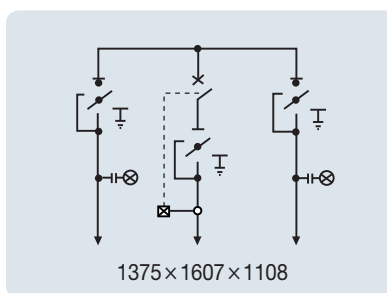

LLCL (3L1C)

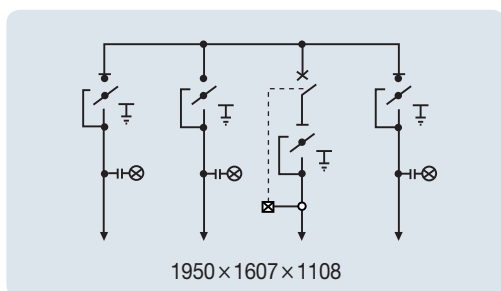

LCCL (2L2C)

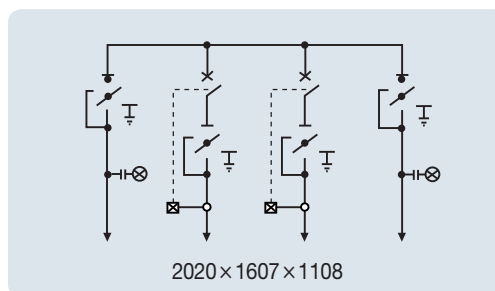

Susol RMU

12/17.5/24kV Switch-Fuse Feeder Non-Extensible RMU

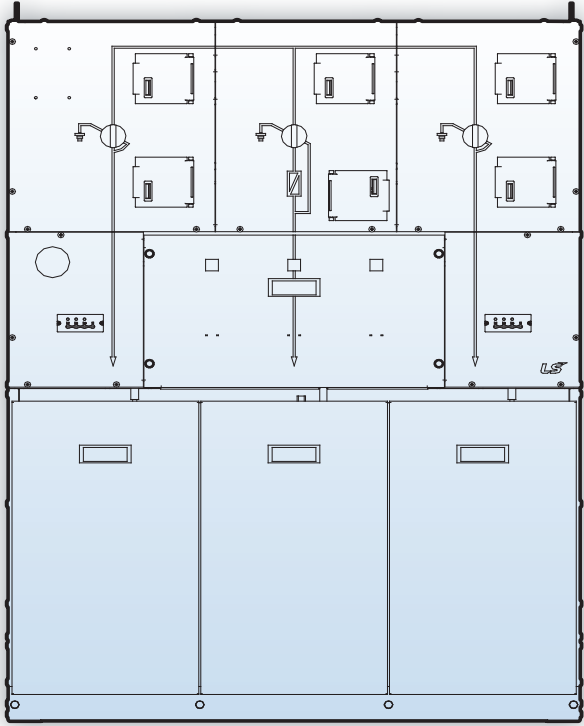

- Consists of two circuit LBS and one circuit Switch-Fuse in a single chamber
- Protects equipment using Switch Fuse
- Complete Sealing System
- Increase durability through S/S application
- L: Load break switch
- C: Vacuum circuit breaker

Applicable type

[W×H×D, mm]

RF (1R1F)

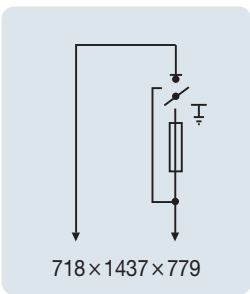

LF (1L1F)

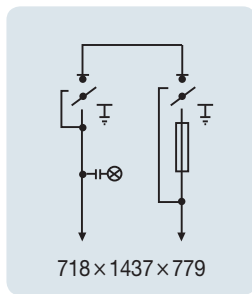

LFL (2L1F)

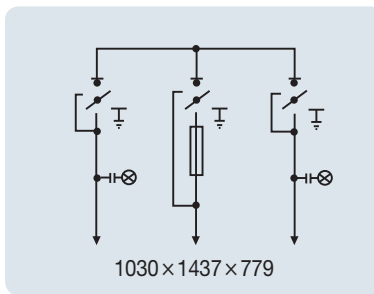

LLFL (3L1F)

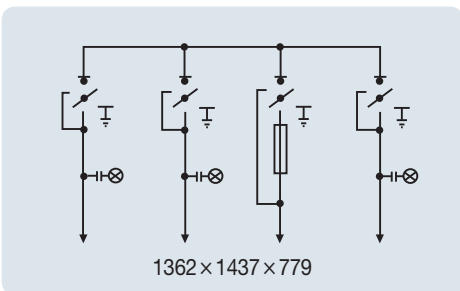

LFFL (2L2F)

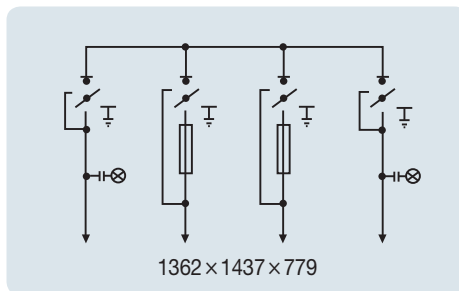

12/17.5/24kV LBS Feeder Non-Extensible RMU

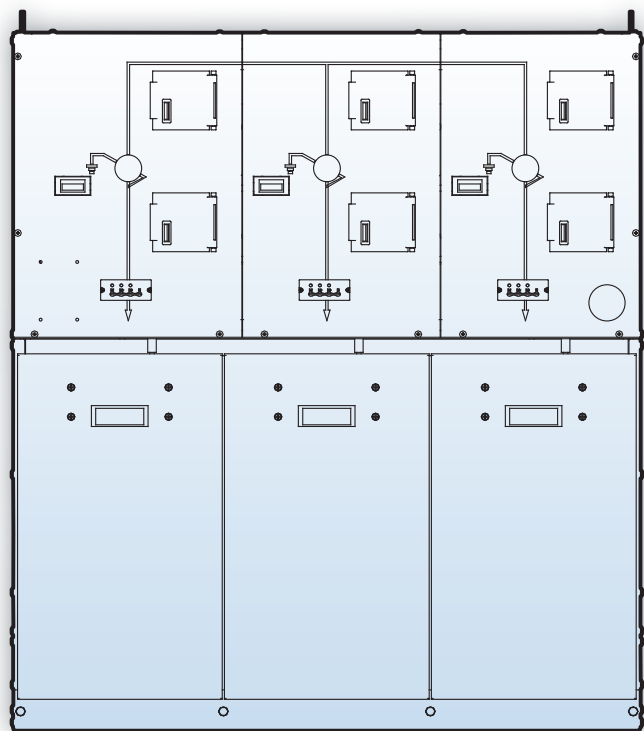

- Complete Sealing System
- Increase durability through S/S application
- L: Load break switch

Applicable type

[W×H×D, mm]

LR (1L1R)

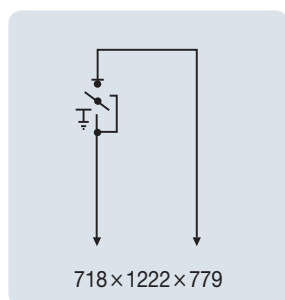

LLL (3L)

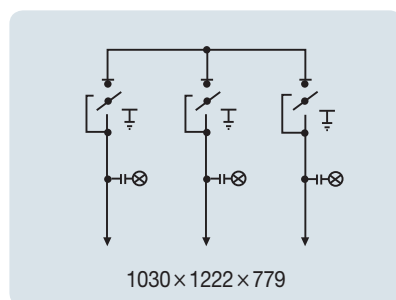

LLLL (4L)

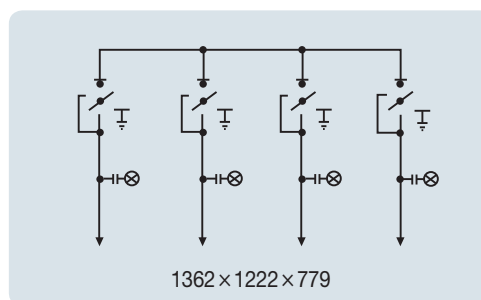

Susol RMU

Extensible RMU

- Protects equipment using Switch Fuse
- Complete Sealing System
- Increase durability through S/S application
- L: Load break switch
- C: Vacuum circuit breaker



12/17.5/24kV Extensible RMU

[W×H×D, mm]

R	L	C	F
411 × 1456 × 779	411 × 1456 × 779	521 × 1456 × 779	521 × 1456 × 779

Trip Relay

Standard OCR

- Performing optimum relay operation
- Overload protection
 - 51T Protection characteristic (Curve selection)
 - 51D Protection characteristic (Definite time characteristic)
- Ground fault protection
 - 51ND Protection characteristic (Definite time characteristic)
- Remote Trip function • Self Powered
- Viewing fault records via PC Manager



1 LED: Indication of trip information and power status

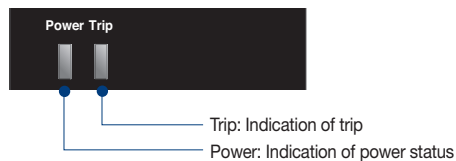

2 Reset key: Trip initialization

Premium OCR

- Dual-powered protective relay
 - Self-Power (CT)
 - Auxiliary Power: AC/DC 100~220V 50/60Hz
- Overload protection
 - Low current region (definite/inverse time characteristics)
 - High current region (instantaneous time characteristic)



2 User interface button



- Ground fault protection
 - Low current region (definite/inverse time characteristics)
 - High current region (instantaneous time characteristic)
- LCD user interface
- Event/Fault history search function
 - 128 system events can be saved
 - 10 fault events can be saved
 - 1 fault waveform can be saved
- Remote monitoring function (RS-485 network)

1 LED: Indication of trip information and power status

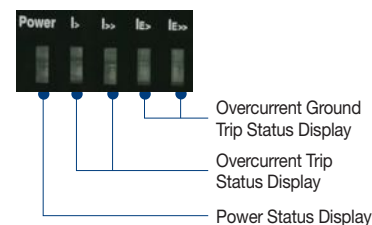

- 3 I>: 51T current setting
tI>: 51T time delay and lever setting
- 4 Cv: 51T operation curve setting
- 5 I>>: 51D current setting,
tI>>: 51D time delay setting
- 6 In: rated current setting
- 7 IE>: ground fault current setting,
tIE>: ground fault time delay setting
- 8 Automatically tripped: to protect from fault current when a fuse is blown

Optional components

CT (Current transformer)



Max. system voltage	kV	0.6
Primary current	A	7.2 / 14/4 / 28.8 / 57.6 / 115.2 / 230.4
Secondary current	A	0.075
Rated burden	VA	0.1
Accuracy class		10P80
Short time-current	KA / 1s	21
Rated frequency	Hz	50 / 60

Susol RMU

Dimensions

12/17.5/24kV Non-Extensible CB Feeder RMU

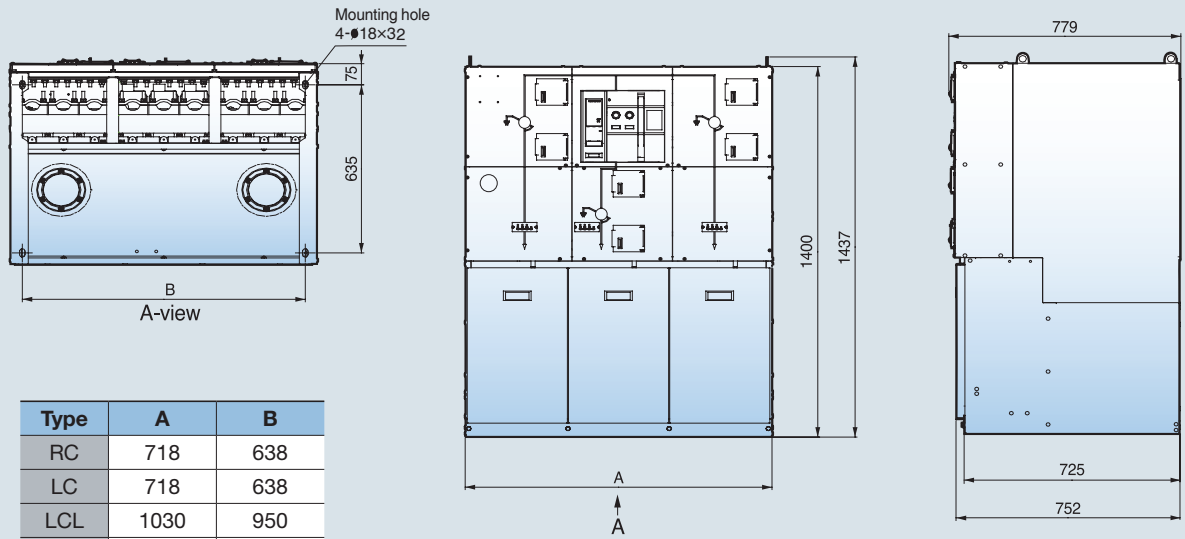

Type	A	B
RC	718	638
LC	718	638
LCL	1030	950
LLCL	1362	1282
LCCL	1362	1282

36kV Non-Extensible CB Feeder RMU

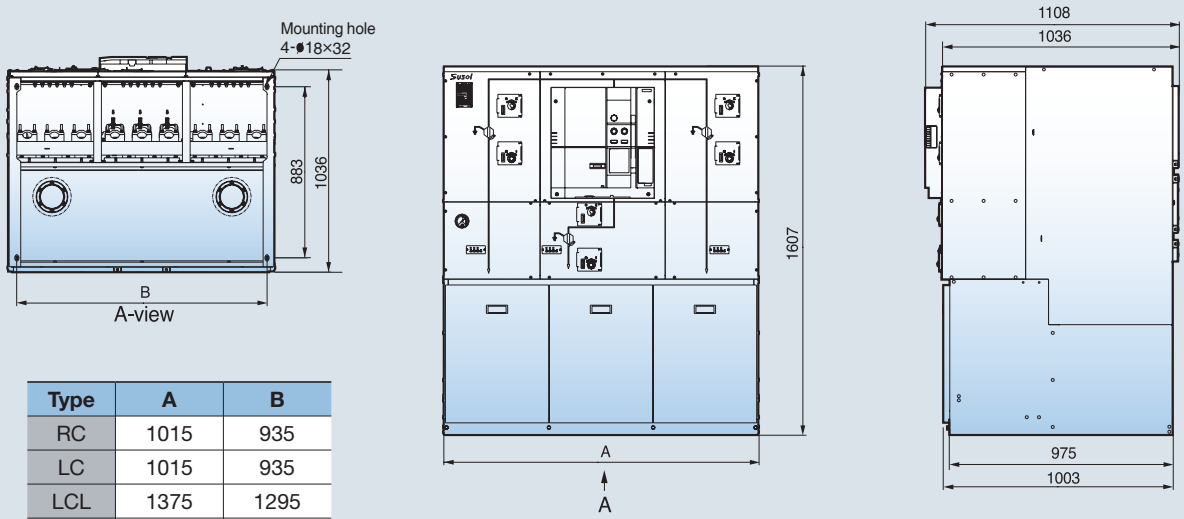

Type	A	B
RC	1015	935
LC	1015	935
LCL	1375	1295
LLCL	1950	1870
LCCL	2020	1940

12/17.5/24kV Non-Extensible Switch-Fuse Feeder RMU

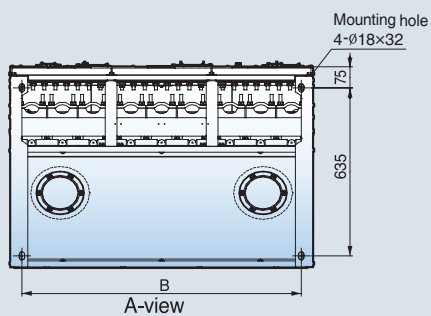

Type	A	B
RF	718	638
LF	718	638
LFL	1030	950
LLFL	1362	1282
LFFL	1362	1282

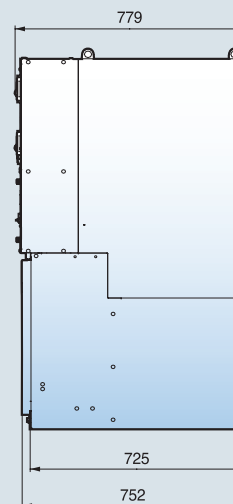
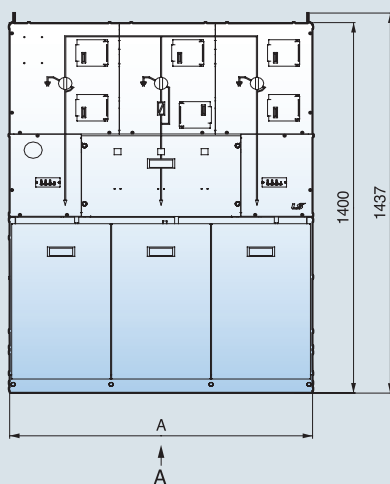

36kV Non-Extensible CB Feeder RMU

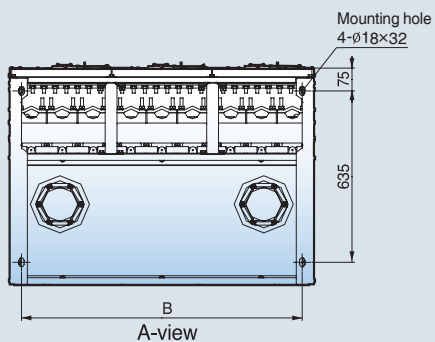

Type	A	B
LR	718	638
LLL	1030	950
LLLL	1362	1282

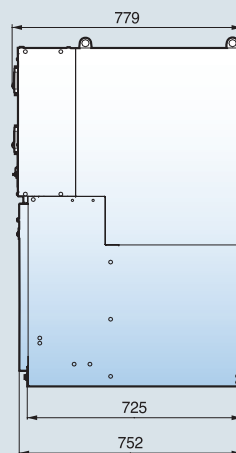
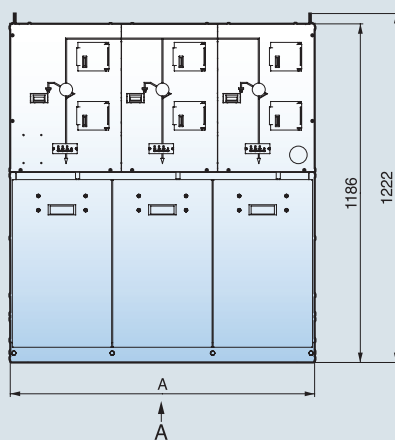

Susol RMU

Dimensions

12/17.5/24kV Extensible RMU

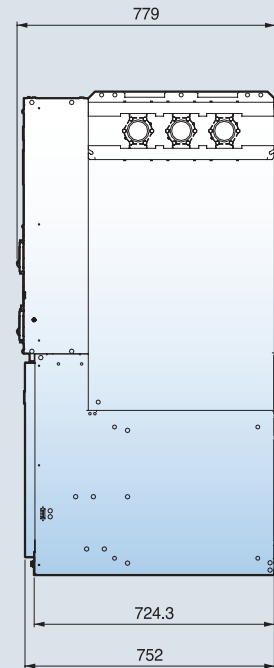
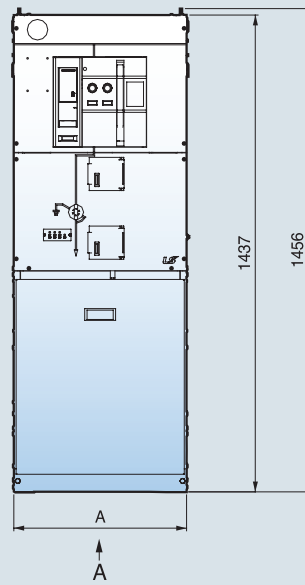
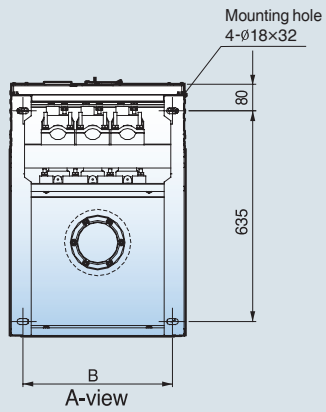

Type	A	B
R	411	341
L	411	341
C	521	451
F	521	451

Cast Resin Transformer

Characteristics

- Applicable to wind power plant
- Superior shock voltage (125kV BIL)
- Strengthening seismic performance (scale 8.0)
- Low noise and high efficiency
- Up to 36kV voltage and 25MVA capacity



Ratings

Division		Standard specification				
Installation place		Indoor(Enclosure needed for outdoor)				
Applicable standard		KS C 4311				
Frequency		60				
Insulation kind		F type				
Coil temperature rise		100K				
1st rated voltage	kA	22.9kV			6.6 or 3.3kV	
1st tap voltage	V	F23900-R22900-21900-20900-19900			F6900-R6600-6300-6000-5700 F3450-R3300-3150-3000-2850	
2nd rated voltage		6.6 or 3.3kV	380-220V	220-110V	380-220V	220-110V
Phase		3P	3P	1P	3P	1P
Angular displacement		Dd0	Dyn11	-	Dyn11	-
Impulse withstand voltage	(1st/ 2nd) kV	95 / 40(20) 125 / 40(20)	95 / - 125 / -	95 / - 125 / -	40(20) / -	40(20) / -
Normal frequency withstand voltage	(1st/ 2nd) kV	50 / 20(10)	50 / 3	50 / 3	20(10) / 3	20(10) / 3
Rated capacity	kVA		100	100	100	100
			200	200	200	200
			300	300	300	300
			400	400	400	400
		500	500	500	500	500
		600	600	600	600	600
		750	750	750	750	750
		1000	1000	1000	1000	1000
		1250	1250		1250	
		1500	1500		1500	
		2000	2000		2000	
		2500	2500		2500	
		3000	3000		3000	
		4000				
5000						
6000						
7500						
8500						
10000						

* The above descriptions are standard specifications, but other specifications are available according to orders. (-36kV, -25MVA)

* The () in the impulse withstand voltage and the normal frequency withstand voltage is insulation classes for 3.6kV.

Cast Resin Transformer

Standard components



1st terminal

This is connected to the inlet cable, so check the bolt tightening condition before inputting power.



2nd terminal

This is connected to the flexible bus and cable in the 2nd load side, so check the bolt tightening condition before inputting power.



Grounding terminal

This is attached on the bottom frame, so check the grounding condition before inputting power.



Tap change terminal

To change the 2nd voltage of the transformer, turn off the tap and adjust the tap terminal.

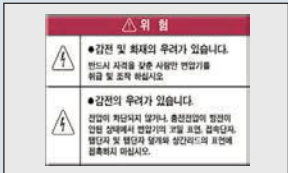

Danger mark

Touching the coil surface during operation of the transformer can cause danger, so never touch it during operation



Lifting eye

This is attached on the top of the top frame, so use it to lift the transformer.

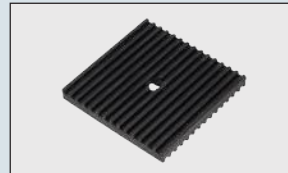

Cushion rubber

Insert cushion rubber between the transformer bed frame and the ground to prevent iron core vibrations from transferring to the floor during operation to reduce noises.



Tap change terminal cover Insulate

The conductor part of the tap terminals to secure an insulation distance and improve safety.

Dimensions

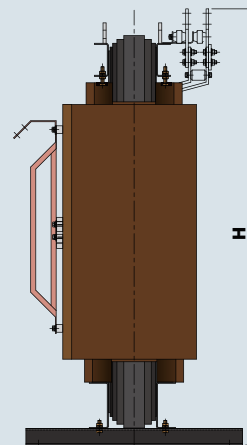
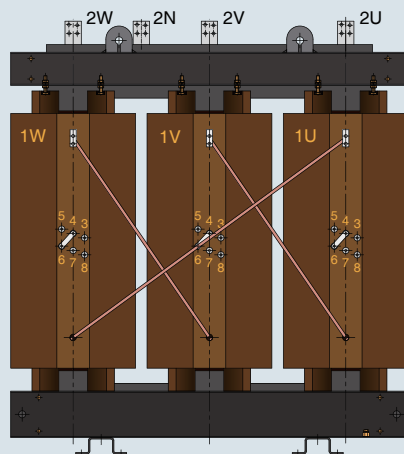
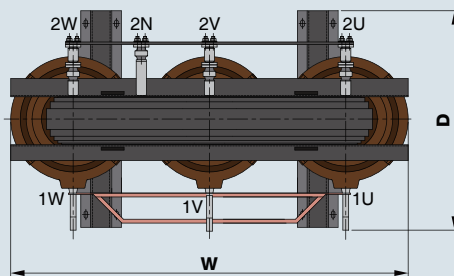

Installation and operation conditions

Pre-checking and maintenance are essential to increase the lifespan and efficiency of the product. Maintaining by all means because the maintenance of cast resin transformers is simple compared to other kinds.

Checkpoints when installing cast resin transformers

- **Installation condition**

- The installation place shall be clean, have no worry of flooding, and have no danger of water falling from the ceiling.
- The installation place shall have a ventilation structure to ventilate the heat generated from the transformer enough.

- **Checking of cast resin transformers that are in a long-term storage condition**

- If dust is accumulated after long-term storage of cast resin trans-formers, then remove dust using a vacuum cleaner or blow out dust using a compressor and wipe out dust using a dry cloth.

- **The vinyl packing for prevention of foreign substances such as dust, screws, nuts and washers from invading shall be maintained until power is inputted after installation.**

- **Torque management when connecting the low voltage terminal**

Bolt	M8	M10	M12	M16
Torque	125	250	405	1500

Unit: kgf.cm

Caution when connecting the terminals

When connecting cables or busbars to the 1st, 2nd terminals, avoid mechanical stresses to the 1st, 2nd terminals, and especially when connecting busbars, use flexible busbars by all means to reduce mechanical stresses due to transformer vibrations. Connecting busbars directly to the 1st, 2nd terminals can loosen the connection parts or cause abnormal noises due to transformer vibrations during operation.

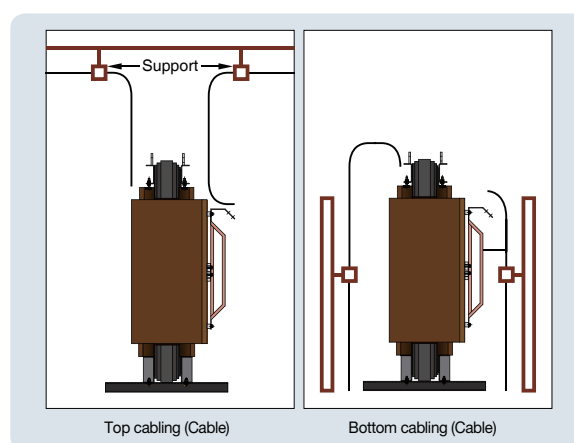

How to minimize transformer noises when installing transformers

- Install cushion rubber beneath the bed frame.
- When installing transformers, separate them mechanically from their enclosures to prevent vibrations of the enclosures.
- When connecting terminals, use flexible busbars.
- The transformer installation places shall be rigid and maintain horizons well.
- Large-capacity transformers shall be installed near pillars of the building to reduce vibrations.
- Avoid corners of the wall for installation.
- Install non-flammable sound-absorbing materials inside the panels if necessary.

Cast Resin Transformer

Considerations for ventilation

Vent height and vent area

- In the case of natural cooling, ventilation of the enclosure shall discharge the heat generated from total heat loss of the transformer enough via natural convection.
- Proper ventilation is realized by the inflow of cold air from the inlet A and the outflow of hot air through the outlet A' located at a height H.

Forced ventilation

- When the average ambient temperature is higher than 20°C or the transformer is operated often in an overload condition, forced ventilation using fans is necessary if the vent area is less than the standard.

$$A = \frac{HL}{0.1 \sqrt{H \Delta \theta a^3}} \quad (m^2)$$

$$A' > A \times 110\%(\text{min.})$$

A : Required inlet area (m²)

A' : Required outlet area (m²)

$\Delta \theta a$: Air temperature rise (K) = 15K (Approximate value)

HL : Heat loss (kW)

H : Distance from the center of the outlet and the center of the TR (m)

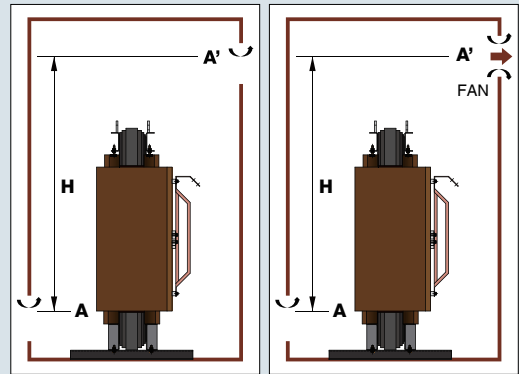

Minimum isolation distance

- Epoxy resin surface - Ground
- Insulation-reinforced inter-phase lead surface – Insulation cable

Voltage	Withstand voltage (kV)	Impulse voltage (kV)	Isolation distance (mm)
1.1kV or less	3	-	10
6.6kV or less	20	60	50
15kV or less	38	75	70
22.9kV or less	50	95	100
		125	150

Checkpoints before receiving power

- Remove the packing vinyl cover and check the wiring condition, isolation distance, foreign substance residuals, component breakage, bolt torque, etc.
- Check if the wiring was realized according to the nameplate.
- Measure the insulation resistance using a DC1000V insulation tester(Megger).

Maintenance / Repair

General use environment

Remove dust using a vacuum cleaner and blow out the overaccumulated dust using a dry compressor every year. the cleaning period can differ depending on the use environment. during maintenance work, check the bolt mounting conditions using a torque wrench.

A/S requesting method

If transformer-related A/S is necessary, tell the serial number on the nameplate of the cast resin transformer and the phenomenon exactly for quick and exact A/S.

Oil-Immersed Transformer

Characteristics

- Applicable to solar/wind power plant
- Mobile transformer (Connection type)
- Quality control through multiple tests
- Various accessories available
- Up to 72kV voltage and 80MVA capacity



LS transformer adopts a structure that can reduce the loss, and it ensures the electrical stability of the transformer by selecting the high efficiency and the optimum insulation structure. Also, it realizes the optimum cooling system, seismic condition considering the short-circuit mechanical power and external shock occurred in the transformer in case of system failure. And strong design of structure that can endure the impact during transportation.

Ratings

Applicable specifications		
Applicable standard		IEC 60076 / ANSI(IEEE) C57
Installation location		Outdoor / Indoor
Frequency		50 / 60Hz
Thermal class		A type 105°C
Winding temp. rising		65K
Oil Temp. rising		60K
Cooling method	Internal	ON / OF / OD
	External	AN / AF / WF
Voltage		Up to 69kV
Capacity (MVA)		Up to 80MVA
Conductor		Al or Cu

Oil-Immersed Transformer

Standard components

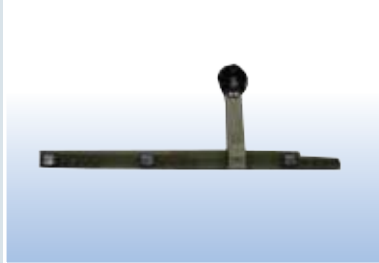

Tap changer

The tap changer is a device for adjusting the voltage, No load tap changer and on-load tap-changer, etc. use.



Breather

Breather is used to prevent deterioration and aging of insulating oil. It consists of two containers filled with moisture absorbent and insulating oil.

* 3000kVA or less is not required.



Winding temperature indicator

Winding temperature indicator do not directly measure the winding temperature but indirectly measure it using a current transformer (BCT) and a temperature detector It can be used by alarm or break contact.



Oil temperature indicator

Oil temperature indicator is located in the protective pipe attached to the transformer enclosure and indicates the temperature of oil level of the top of transformer during operation. It can be used by alarm or break contact.



Oil level gauge

This displays the height of the oil level of the tank and the conservator.



Buchholz relay

Buchholz relay is installed between the pipes connecting the transformer and the controller. Alarm and trip signal is generated by detecting changes of gas and flow rate when any internal error occurs.



Pressure relief device

Pressure relief device releases the pressure generated by an accident of the transformer to the outside air, and is attached to the cover of the transformer enclosure. It has a alarm and a break contact.



Sudden pressure relay

Sudden pressure relay is operated at the time of accident such as short circuit and flash over of the transformer, and has alarm and trip contact.



Conservator

It is responsible for contraction and expansion of insulation oil due to changes in oil temperature.

* 3000kVA or less is not required.



Ratings

Applicable specifications	
Applicable standard	ANSI, IEEE, NEMA and IEC
Voltage	Up to 138kV
Capacity	Up to 50MVA
Available fluids	Mineral oil, silicon oil and FR3 (Vegetable oil)
Tap changer type	DETC and OLTC

Dimensions

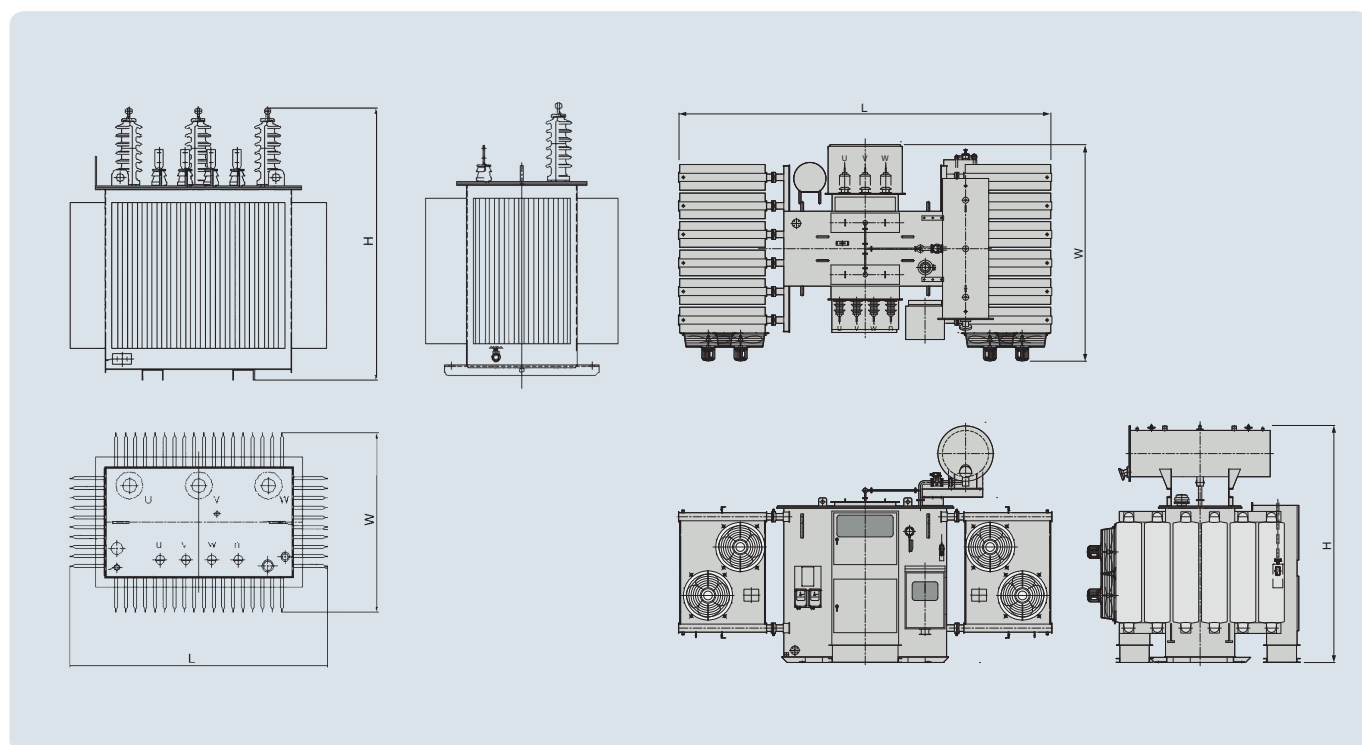

Oil-Immersed Transformer

Dimensions

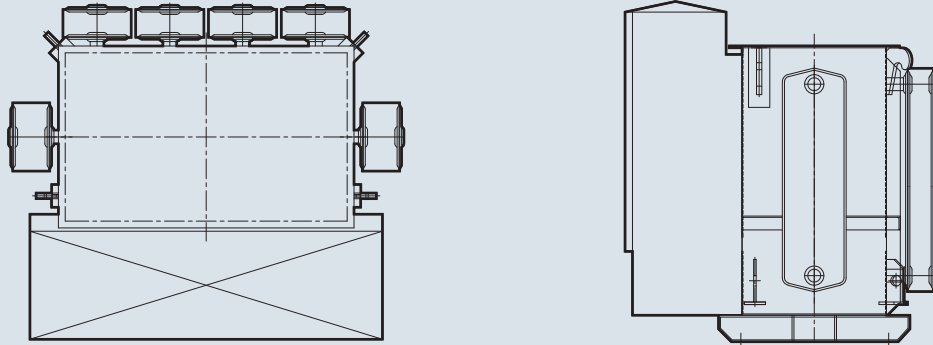

Information required for Order

1. Details of markings to be applied to the transformer (for example IEC 60076-1 or ANSI/IEEE 57.12.40)
2. Constant of the system
3. Frequency
4. Cooling type (for example, self-cooling or forced cooling)
5. Rated voltages of primary and secondary windings
6. Whether tabs are required Mark type of tap changer, if necessary
7. Number and range of tabs
8. The maximum voltage of the device for each winding
9. Method of system grounding (for each winding)
10. Isolation rating for each winding
11. Winding symbol and neutral terminal (Vector Group)
12. Characteristics of installation, assembly, transportation and handling Limitations on Dimensions and Weights
13. Auxiliary power (fans, switches, alarms, etc.)
14. Attachment location of other necessary equipment, instruments and nameplate
15. Types of Oil Preservation Methods
16. For multi-winding transformers, especially in case of multi-winding single phase transformers, active and reactive outputs are required for combination and statement of power load.
17. Specified impedance for a pair of windings, in case of a short-circuit impedance multi-winding transformer
18. Altitude, when it exceeds 1,000m above sea level
19. Installation area where seismic activity is expected
20. Possibility of unbalanced load Describe unbalanced conditions if possible
21. Frequent overcurrent effects of the transformer
22. Overload of the intended periodic cycle
23. Whether an parallel operation is used or not

Memo

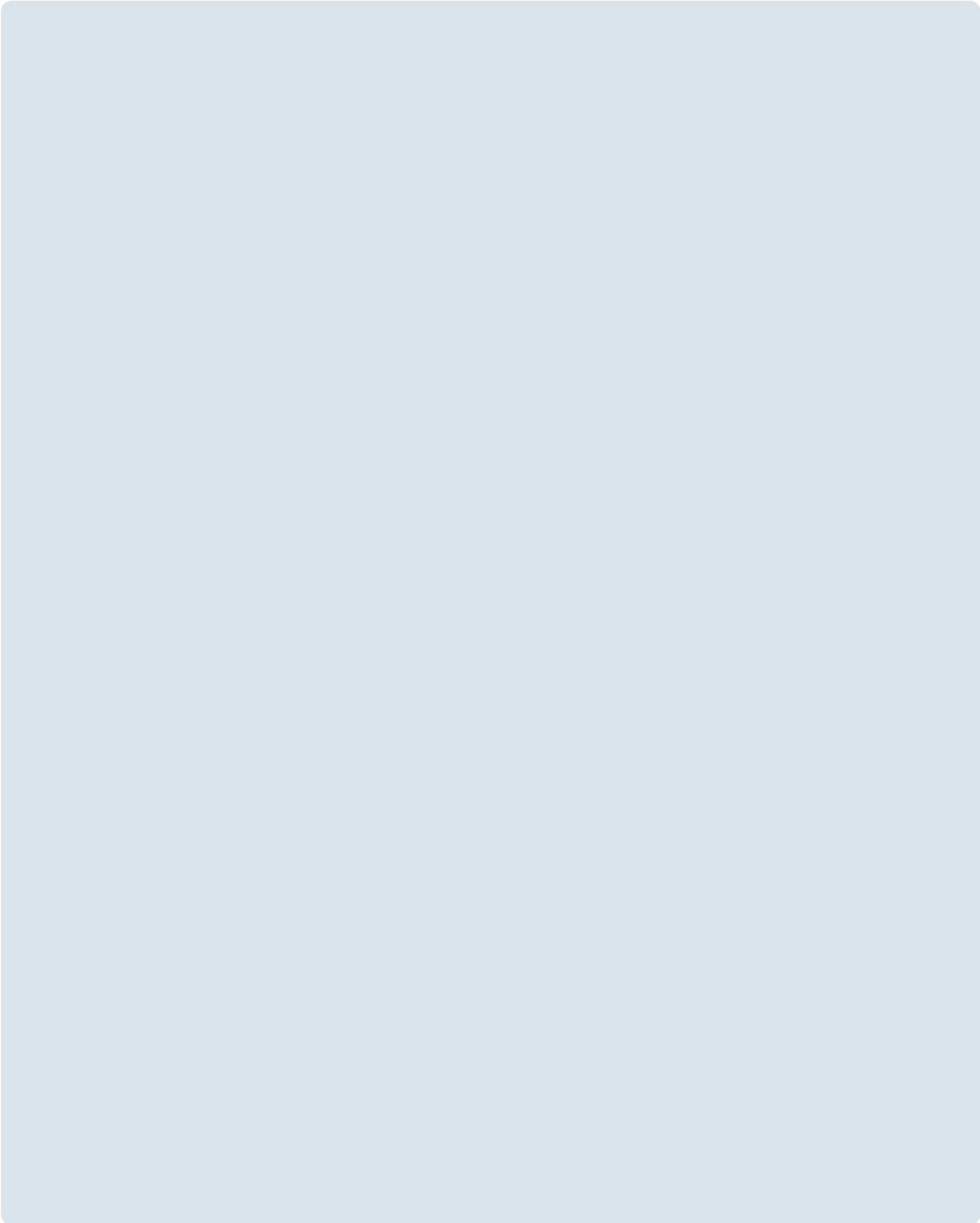



Safety Instructions

- For your safety, please read user's manual thoroughly before operating.
- Contact the nearest authorized service facility for examination, repair, or adjustment.
- Please contact qualified service technician when you need maintenance. Do not disassemble or repair by yourself!
- Any maintenance and inspection shall be performed by the personnel having expertise concerned.



- According to The WEEE Directive, please do not discard the device with your household waste.



www.ls-electric.com

■ **Headquarter**

127 LS-ro (Hogye-dong) Dongan-gu, Anyang-si, Gyeonggi-Do, 14119, Korea

■ **Seoul Office**

LS Yongsan Tower, 92, Hangang-daero, Yongsan-gu, Seoul, 04386, Korea
Tel. 82-2-2034-4916, 4684, 4429

■ **Overseas Subsidiaries**

- **LS ELECTRIC Japan Co., Ltd. (Tokyo, Japan)**
Tel: 81-3-6268-8241 E-Mail: japan@ls-electric.com
- **LS ELECTRIC (Dalian) Co., Ltd. (Dalian, China)**
Tel: 86-411-8730-5872 E-Mail: china.dalian@ls-electric.com.cn
- **LS ELECTRIC (Wuxi) Co., Ltd. (Wuxi, China)**
Tel: 86-510-6851-6666 E-Mail: china.wuxi@ls-electric.com.cn
- **LS ELECTRIC Vietnam Co., Ltd. (Hanoi, Vietnam)**
Tel: 84-222-2221-110 E-Mail: vietnam@ls-electric.com
- **LS ELECTRIC Middle East FZE (Dubai, U.A.E.)**
Tel: 971-4-886-5360 E-Mail: middleeast@ls-electric.com
- **LS ELECTRIC Europe B.V. (Hoofddorp, Netherlands)**
Tel: 31-20-654-1424 E-Mail: europartner@ls-electric.com
- **LS ELECTRIC America Inc. (Chicago, USA)**
Tel: 1-800-891-2941 E-Mail: sales.us@lselectricamerica.com
- **LS ENERGY SOLUTIONS LLC (Charlotte, USA)**
Tel: 1-704-587-4051 E-Mail: cmfeldman@ls-es.com
- **LS ELECTRIC Türkiye Co., Ltd. (Istanbul, Türkiye)**
Tel: 90-212-806-1252 E-Mail: turkiye@ls-electric.com
- **LS ELECTRIC IBERIA S.L.U. (Madrid, Spain)**
Tel: 34-910-28-02-74 E-Mail: iberia@ls-electric.com

■ **Overseas Branches**

- **LS ELECTRIC Tokyo Office (Japan)**
Tel: 81-3-6268-8241 E-Mail: tokyo@ls-electric.com
- **LS ELECTRIC Beijing Office (China)**
Tel: 86-10-5095-1631 E-Mail: china@lselectric.com.cn
- **LS ELECTRIC Shanghai Office (China)**
Tel: 86-21-5237-9977 E-Mail: china@lselectric.com.cn
- **LS ELECTRIC Guangzhou Office (China)**
Tel: 86-20-3818-2883 E-Mail: china@lselectric.com.cn
- **LS ELECTRIC Chengdu Office (China)**
Tel: 86-28-8670-3201 E-Mail: china@lselectric.com.cn
- **LS ELECTRIC Qingdao Office (China)**
Tel: 86-532-8501-2065 E-Mail: china@lselectric.com.cn
- **LS ELECTRIC Nanjing Office (China)**
Tel: 86-25-8467-0005 E-Mail: china@lselectric.com.cn
- **LS ELECTRIC Bangkok Office (Thailand)**
Tel: 66-90-950-9683 E-Mail: thailand@ls-electric.com
- **LS ELECTRIC Jakarta Office (Indonesia)**
Tel: 62-21-2933-7614 E-Mail: indonesia@ls-electric.com
- **LS ELECTRIC Moscow Office (Russia)**
Tel: 7-499-682-6130 E-Mail: info@lselectric-ru.com
- **LS ELECTRIC America Western Office (Irvine, USA)**
Tel: 1-949-333-3140 E-Mail: america@ls-electric.com
- **LS ELECTRIC India Office (India)**
Tel: 91-80-6142-9108 E-Mail: info_india@ls-electric.com
- **LS ELECTRIC Singapore Office (Singapore)**
Tel: 65-6958-8162 E-Mail: singapore@ls-electric.com
- **LS ELECTRIC Italy Office (Italy)**
Tel: 39-030-8081-833 E-Mail: italia@ls-electric.com