



Beyond X™

**Cast Resin
Transformer**



LS ELECTRIC

High quality



High efficiency



Eco-friendly





CAST RESIN TRANSFORMER

Closer than you imagine

Where there is light illuminating and moving around the world from homes to offices and from factories to airports, power is supplied everywhere by LS ELECTRIC. Our products bring light to you, wherever you are.

Contents

Features	4
Applications	6
Components	8
Manufacturing and quality management	10
Standard specifications	11
Metasol technical data	12
Installation and operating conditions	14
Global Business	18

Features

Metasol D1 **CAST RESIN TRANSFORMER**

Our transformer complies with IEC standards. The transformer's compact design is more durable than Metasol T1 and T2 with the same specifications and offers lower initial purchasing costs. Various options are available to provide the right solution for each application condition.



“We have an authorized power testing technology center that operates an ISO 9001-certified quality assurance system and performs tests according to IEC 60076 and other international standards.”



This is a compact and high-efficiency product made with cutting-edge technology that is easy to maintain, excellent in short-circuit strength, humidity resistance and non-combustibility, and also suitable for equipment with severe load variations such as electric-train power supply systems, etc.

Short-circuit strength

The coils are vacuum-cast with epoxy resin, providing heavy-duty electrical and mechanical strength against short-circuit conditions.

Suitable for supplying power to equipment with rapidly changing loads

The transformer is designed for electric train power supply units, rolling equipment and more.

Impulse voltage strength

The transformer has excellent impulse voltage strength owing to the reliable insulation performance of epoxy resin and the split-winding design.

Easy to maintain

The transformer doesn't need insulation oil exchange or separate fire-fighting equipment.

Humidity resistance

The high voltage coils are vacuum-cast to prevent moisture ingress during long-term storage, allowing energization without drying.

Reduction of environmental impact

The LS Cast Resin Transformer has obtained F1, E2, and C1 certifications from CESI (Italy), and E3 and C3 certifications from KERI (Korea), in accordance with IEC 60076-11.

Overload tolerance

The LS Cast Resin Transformer has a robust overload tolerance compared to a normally used oil-immersed transformer, even under temporary overload conditions.

Non-combustible

The LS Cast Resin Transformer uses noncombustible epoxy resin to prevent fires caused by electric arcs and processes self-extinguishing properties.

Overload capability

The LS Cast Resin Transformer provides reliable overload capability compared to conventional oil-immersed transformers, even under temporary overload conditions.

Applications

**“LS Cast Resin Transformers can be used in various fields.
Here are some possible applications.”**

1	2	3
4	5	6
7	8	9

1. Semiconductor or LCD factories
2. Commercial building and apartments
3. Subway or high-speed railways
4. Thermal power plants, transformer stations and petrochemical plants
5. Hospitals
6. Solar photovoltaic systems
7. Automobile factories or rolling mills
8. Airports and ports
9. Hydropower plants and water treatment facilities

Operations requiring high reliability

Nuclear power plants, semiconductor factories, automotive manufacturing facilities, petrochemical factories, drilling ships, dock cranes, rolling mills, international airports, thermal power plants, transformer substations, etc.

Power supply for complex facilities

High-rise building, commercial building and apartment

Public places requiring fire prevention

Underground store, subway, hotel, hospital, etc.

Places requiring protection in rugged environments such as water contamination, etc.

Water treatment facilities and hydro-power plants

Renewable energy

Solar photovoltaics, wind power, etc.

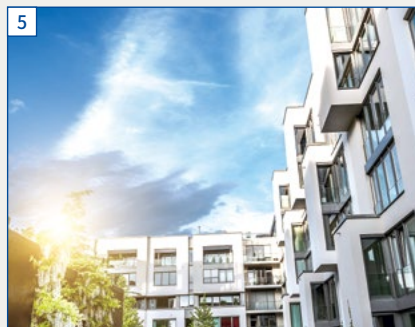
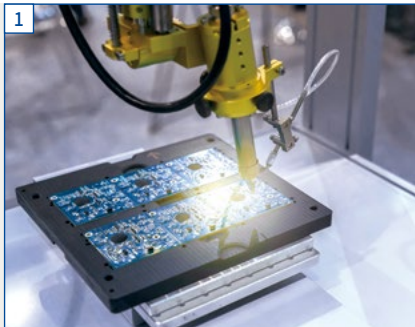

Special-purpose Cast Resin Transformer

LS Cast Resin Transformers are widely used for general power distribution and power generation. The units can be customized to meet the requirements of customer order specifications.

* For special-purpose transformers, please contact us for more information

Ground transformer

- This transformer provides a neutral point for grounding in power systems where a proper grounding method is difficult to implement.
- The unit mainly uses Wye-Delta or Zigzag connections, and is designed for short-time rating.

Equipment test transformer

- This type of transformer is used for short-circuit and other related tests for equipment. It handles large currents and requires a special insulation design considering transient voltages due to frequent switching.

Subway power supply transformer

- This transformer is designed for locations with rugged environments, such as exposure to water contamination.

Transformer for nuclear power plant

- This transformer meets the requirements (seismic and environmental) for Class 1E electrical equipment required by nuclear power plants.
- The unit carries quality assurance qualification certificates required by the Korea Electric Power Industry Code (KEPIC).

Harmonic mitigating transformer

- If a conventional transformer is used on a load that contains distorted electrical waves or harmonics rather than a pure sine wave, it causes problems such as overheating, noise increase, etc.
- This transformer is specially designed based on harmonic component analysis data (K-Factor). It can be applied to loads such as communication equipment, rectifiers, inverters, etc.

Ship transformer

- This transformer meets the severe environmental conditions of ships that require high reliability such as vibration resistance and salt resistance, etc.
- AFWF (forced water cooling type transformer) technology is used considering that the temperature in transformer stations is high due to the characteristics of ships.
- We have secured ship class certifications such as ABS, BV, GL, DNV, KR, etc. for this transformer.

Variable Voltage Variable Frequency (VVVF) transformer

- This is used as an input/output transformer for 6-pulse, 12-pulse, and 24-pulse

Input transformer

- This is used when the system voltage differs from the VVVF input voltage or when isolation is needed.
- The input transformer isolates VVVF from the system and reduces short-circuit currents.
- Using an electromagnetic shield specially designed between high and low voltage coils not only reduces harmonics generated by the VVVF but also reduces transient voltages introduced from the system to protect VVVF.

Output transformer

- This is used when the VVVF output voltage is different from the motor voltage or when isolation is needed.
- It is generally designed as a step-up transformer.
- This is designed based on data from the rectifier maker because output voltages contain frequency variations, harmonic components and transient DC components.

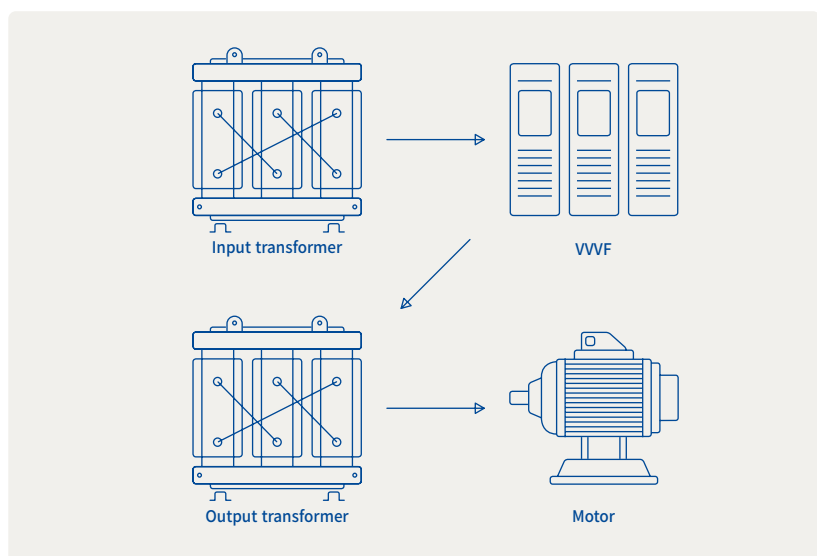

Components

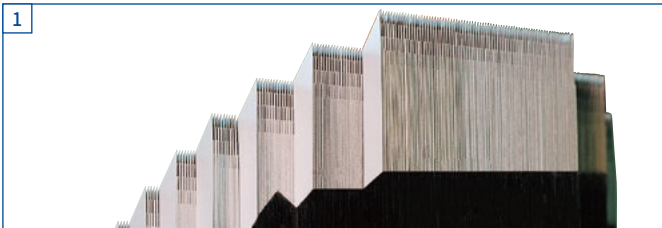
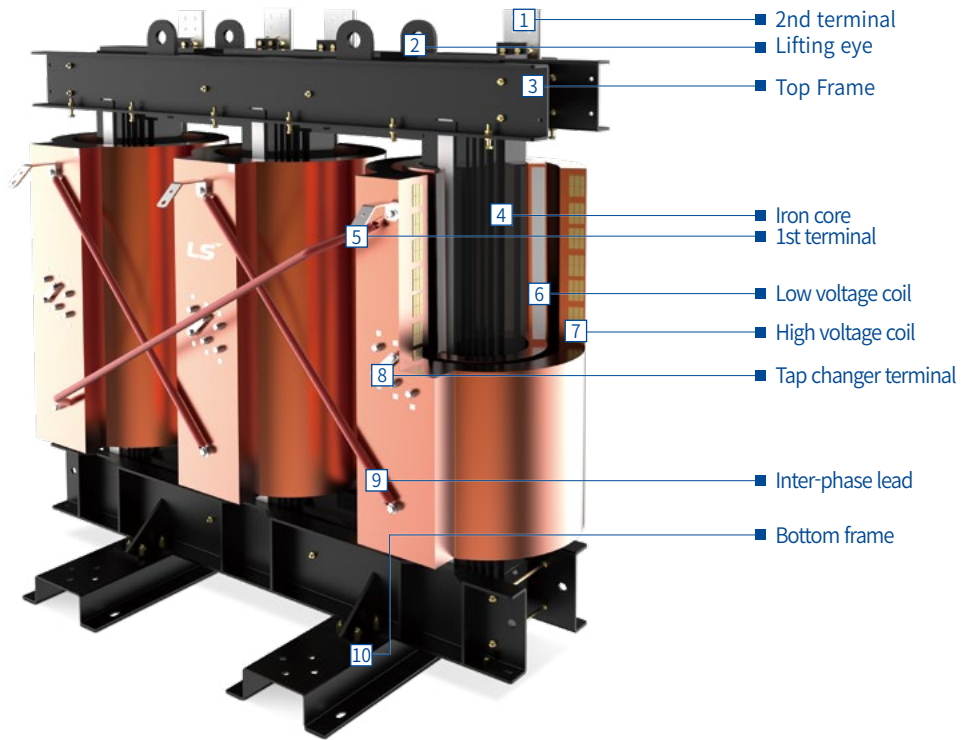

Iron core

The iron core uses high-quality cold-rolled oriented silicon steel plates and a step-lap method to preserve its characteristics, improving no-load loss and current characteristics.

The surface of the iron core is protected by a rust-resistant coating.

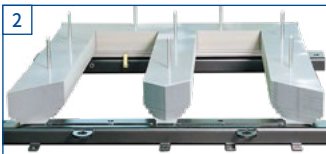

1. Step lap core
2. Core stacking
3. Core assembly

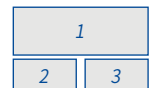

High voltage coil

The high voltage coil is vacuum-cast with epoxy resin, using high-conductivity conductors to achieve superior mechanical and electrical performance, short-circuit strength, and insulation performance.

Low voltage coil

The low voltage coil is cast in epoxy resin using conductors and prepreg insulating paper to ensure short-circuit strength and humidity resistance.

1. HV coil vacuum cast type
2. LV coil encapsulated cast type
3. LV coil vacuum cast type (Optional)



Standard components



HV terminal

The HV terminal is connected to the inlet cable. Ensure that all bolts are properly tightened before applying input power.



LV terminal

The LV terminal is connected to the flexible bus and cables on the low-voltage load side. Ensure that all bolts are properly tightened before applying input power.



Grounding terminal

The grounding terminal is attached to the bottom frame. Ensure that the grounding condition is verified before applying input power.



Tap change terminal

To change the 2nd voltage of the transformer, turn off the power and adjust the tap terminal.



Danger mark

Do not touch the coil surface while the transformer is operating. It is dangerous.



Lifting eye

The lifting eye is attached to the top frame. Use it when lifting the transformer.

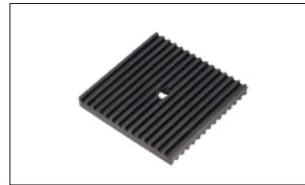

Anti-vibration pad

Insert the anti-vibration pad between the transformer and the ground to prevent vibrations of the iron core from being transmitted to the ground during operation.



Tap change terminal cover

The tap change terminal cover maintains proper insulation distance and enhances safety.

Optional components

Digital thermometer/Controller



P2-300M

3-point temperature measurement, alarm, trip, and fan control



P2-300F

3-point temperature measurement, alarm, trip, fan control, fan fault check, fan operating time/alarm, and step-by-step fan operation



P2-400

4-point temperature measurement, alarm, trip, and fan control



p4-800

8-point temperature measurement, alarm, trip, fan control, fan fault check, fan operating time/alarm, and step-by-step fan operation, voting function, fail safe function, FCD, UL Listed(E549048)

Cooling fan



Low noise cooling fan



Large cooling fan

Other accessories



Bidirectional wheel



Enclosure



Extension busbar

Manufacturing and quality management

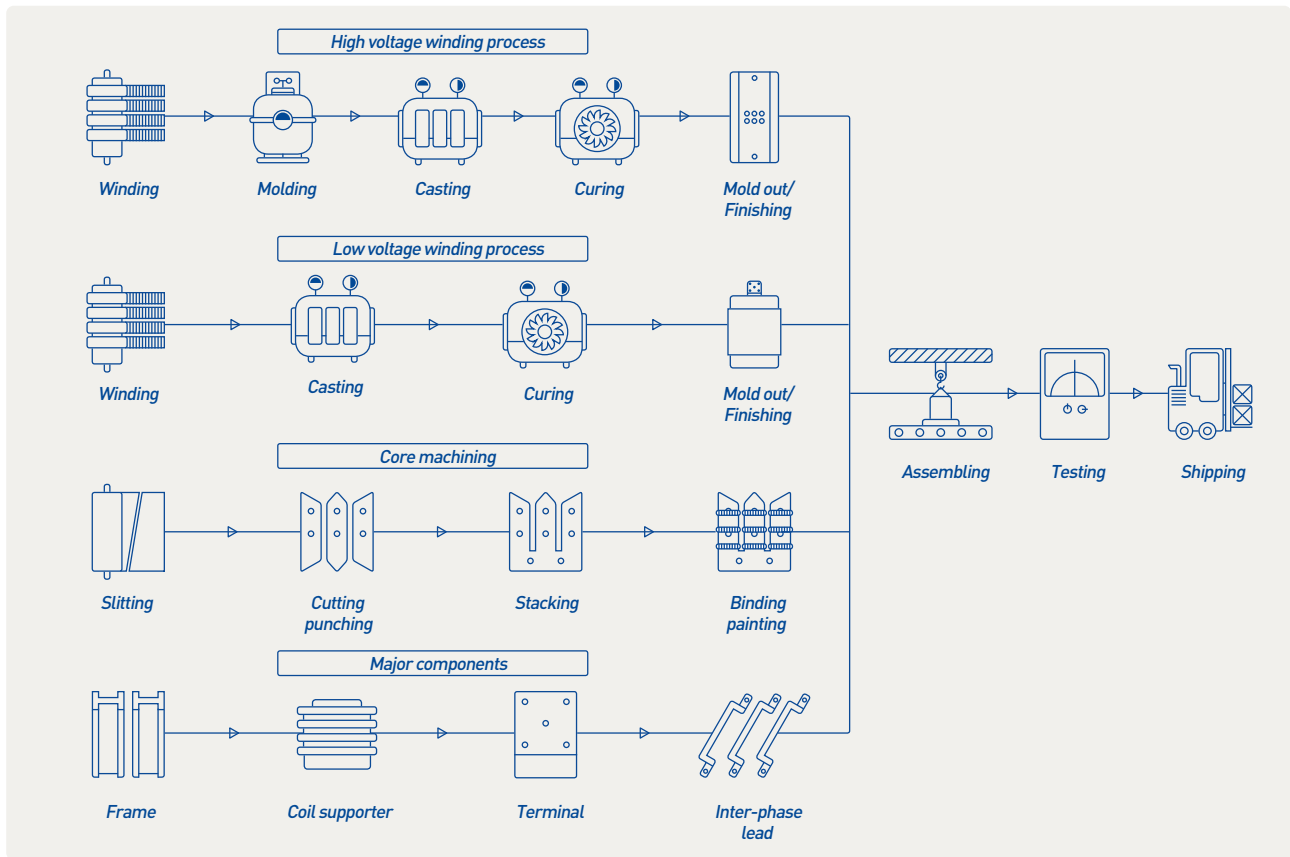

We have an authorized power testing technology center, operating an ISO 9001 certified quality management system and performing tests according to IEC 60076-11, IEEE C57.12.01, KSC 4311, etc.

Routine test

We manage the quality of all transformers produced by our factory according to the ISO 9001 system, and perform tests according to National Standard.

- Structure inspection
- Coil resistance measurement
- Transformation ratio, polarity and angular displacement test
- No-load current and no-load loss test
- Load loss and impedance voltage tests
- Normal frequency withstand voltage test
- Induction withstand voltage test
- Partial discharge test (10pC or less)

Type test

The type test is executed when there is a demand from customers or when changing the type of transformer.

- Full wave lightning impulse test (LI)
- Temperature rise test

Special test

The LS Cast Resin Transformer completed the following tests during product development to verify performance under various environmental conditions:

- Short-circuit test certified by KERI and PT&T
- Noise test according to IEC 60076-10, measuring Sound Pressure Level (Lp)

$$Lw(A) = Lp(A) + 10\log(S)$$

S = 1.25 × H × P
 H : Transformer height
 P : Length of the ellipse connecting the measurement positions

An environment resistance test was performed on the LS Cast Resin Transformer according to the revised standard IEC 60076-11 at an international institution, CESI (Italy) for the first time in Korea.

- Environmental test (moisture-resistance test): Verifies that the transformer operates normally under moisture, water condensation, or contamination conditions at the site.
- Climatic test (thermal shock test): Checks for internal cracks and evaluates performance under rapid temperature or load changes during transportation, storage, and operation.
- Fire behavior test (non-flammability and toxic gas tests): Tests self-extinguishability and whether toxic gases are generated in case of fire.

Standard specifications

Division	Standard specification		
Installation place	Indoor, Outdoor with enclosure		
Applicable standard	IEEE C57.12.01		
Rated frequency, fr [Hz]	60		
Insulation system temperature class (°C)	180 °C	155 °C	
Average winding temperature rise (°C) [k]	80 °C, 115 °C (Optional)	80 °C, 95 °C (Optional)	
Nominal L-L system voltages [kV]	34.5	15	5
HV rated voltage, Ur [kV]	34.5	13.8	4.16
Tapping volatge step, range	5 Taps, $\pm 2 \times 2.5\%$		
LV rated voltage, Ur [V]	480		
Connection symbol	Dyn1 (or Dyn11, Dd0, YNd1, etc.)		
Basic lightning impulse insulation levels (HV/LV) [kV]	150 / 10	95 / 10	60 / 10
Low frequency voltage insulation level (HV/LV) [kV]	70 / 3	40 / 3	34 / 3
Rated Power, Sr [kVA]	225	225	225
	300	300	300
	500	500	500
	750	750	750
	1000	1000	1000
	1500	1500	1500
	2000	2000	2000
	2500	2500	2500
Enclosure	NEMA 1, 2, 3R, etc.		

* The above descriptions are standard specifications, but other specifications are available according to orders. (~34.5 kV, ~30 MVA)



Metasol D1

Typical Performance Data and Dimensions / Weight

Standard : IEEE C57.12.01, DOE 2016 Energy Efficient (225–2500 kVA)

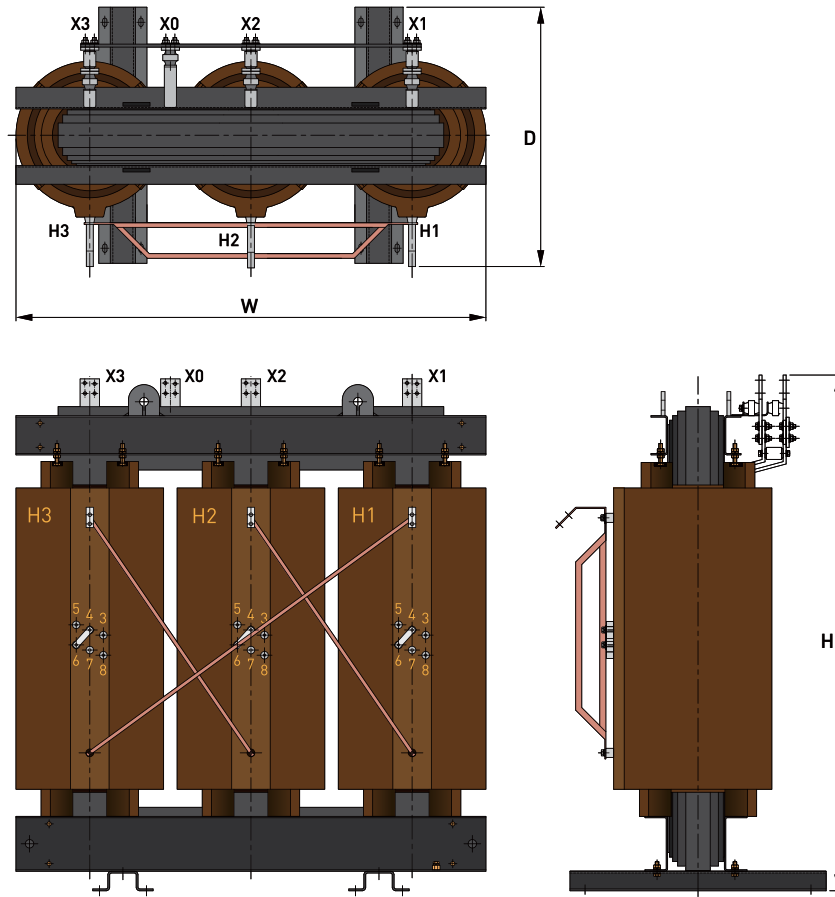

Rated voltage (U_r): 22 kV/380 V

Rated power (kVA)	Impedance voltage: U_k (%)	No-load loss: P_0 (W)	Load loss: PK (W)		Efficiency (%) at 75°C		Exciting Current: IO (%)	Voltage regulation (%)	Sound level: LpA (dB)	Dimensions (inch/mm)				Weight (lbs/kg)
			at 120°C	100% Load	50% Load	Width (W)				Depth (D)	Height (H)	Height+ Wheels		
300	6	1000	4500	98.0	98.5	0.9	2.0	64	49.21/1250	31.49/800	59.05/1500	59.64/1515	2425/1100	
500	6	1600	7500	98.0	98.5	0.9	1.8	64	54.52/1385	35.43/900	65.15/1655	65.74/1670	3417/1550	
600	6	1700	6000	98.6	98.8	0.9	1.5	64	56.29/1430	35.43/900	64.96/1650	65.15/1665	3968/1800	
650	6	1800	8000	98.4	98.7	0.9	1.5	64	58.46/1485	35.43/900	65.15/1665	66.14/1680	4078/1850	
1000	6	2500	11000	98.6	98.9	0.7	1.3	65	65.55/1665	39.37/1000	73.42/1865	74.01/1880	6172/2800	
1500	6	2550	11500	98.7	99	0.7	1.1	67	68.50/1740	39.37/1000	71.25/1810	73.42/1865	7054/3200	
1800	6	3700	13800	98.8	99.1	0.6	1.0	68	72.63/1845	47.24/1200	82.67/2100	87.20/2215	9479/4300	
2000	6.5	3700	16700	99.8	99.1	0.5	1.0	68	72.63/1845	47.24/1200	82.67/2100	87.20/2215	9479/4300	
2500	6.5	4900	16000	99.9	99.1	0.5	0.9	70	79.33/2015	47.24/1200	83.46/2120	87.99/2235	11574/5250	
3200	7	6050	18500	99.0	99.2	0.9	1.0	65	90.35/2295	55.11/1400	85.43/2170	89.96/2285	14770/6700	

Rated voltage (Ur) : 13.8 kV/480 V

95 kV BIL, CU/CU, Temperature Rise : 80 °C (180 °C Class)

kVA	%IZ [%]	%IR [%]	%IX [%]	X/R ratio	No load losses [W]	Full load losses [W] ¹⁾	Total losses [W]	Exciting current [%]	Regulation [%]				% Efficiency at different loads				Audible sound levels [dB]	Width [inches]	Depth [inches]	Height [inches]	Weight [lb]
									at 50% load		at 100% load		25%	50%*	75%	100%					
									pf=1	pf=0.8	pf=1	pf=0.8									
225	5.75	1.30	5.60	4.3	720	3080	3800	0.6	0.73	2.25	1.53	4.53	98.40	98.69	98.57	98.34	58	49.2	32.3	57.3	2866
300	5.75	1.07	5.65	5.3	850	3800	4650	0.6	0.68	2.22	1.43	4.48	98.57	98.81	98.69	98.47	58	49.8	32.5	59.1	3307
500	5.75	0.94	5.67	6.0	1230	5250	6480	0.6	0.57	2.20	1.22	4.32	98.77	98.99	98.90	98.72	60	53.3	35.4	65.0	4409
750	5.75	0.63	5.72	9.1	1900	5700	7600	0.8	0.43	2.05	0.93	4.13	98.81	99.12	99.10	99.00	64	57.5	39.4	66.1	5842
1000	5.75	0.72	5.70	7.9	2150	7450	9600	0.8	0.42	2.03	0.91	4.11	98.96	99.20	99.16	99.05	64	63.2	39.4	71.7	7275
1500	5.75	0.53	5.73	10.8	3050	8800	11850	0.8	0.34	2.14	0.76	4.00	99.05	99.30	99.29	99.22	65	68.5	47.2	73.4	9480
2000	5.75	0.50	5.73	11.5	3750	10900	14650	0.8	0.32	1.97	0.71	3.97	99.12	99.36	99.35	99.27	66	70.5	47.2	80.1	11685
2500	5.75	0.45	5.73	12.7	4350	12250	16600	0.8	0.29	1.94	0.66	3.93	99.19	99.41	99.40	99.34	68	73.8	47.2	84.8	13338

* Meets DOE 2016/NRCAN 2019 Energy Efficiency Regulation for Medium-voltage dry-type distribution transformer
 1) At a reference temperature of 75 °C

Rated voltage (Ur) : 34.5k V/480 V

kVA	%IZ [%]	%IR [%]	%IX [%]	X/R ratio	No load losses [W]	Full load losses [W] ¹⁾	Total losses [W]	Exciting current [%]	Regulation [%]				% Efficiency at different loads				Audible sound levels [dB]	Width [inches]	Depth [inches]	Height [inches]	Weight [lb]
									at 50% load		at 100% load		25%	50%*	75%	100%					
									pf=1	pf=0.8	pf=1	pf=0.8									
225	6.50	0.74	6.46	8.7	1160	1900	3060	0.7	0.48	2.31	1.06	4.67	97.78	98.57	98.70	98.66	58	64.0	42.3	71.5	4850
300	6.50	0.88	6.44	7.3	1330	2640	3970	0.7	0.50	2.32	1.09	4.68	98.05	98.69	98.76	98.69	58	64.0	42.3	72.6	4960
500	6.50	0.86	6.44	7.5	1730	4300	6030	0.6	0.49	2.31	1.07	4.66	98.43	98.89	98.91	98.81	60	65.2	43.1	76.4	5842
750	6.50	0.59	6.47	11.0	2560	4590	7150	0.6	0.36	2.22	0.83	4.49	98.50	99.02	99.09	99.06	64	68.7	47.4	77.6	7275
1000	6.50	0.60	6.47	10.8	2900	6330	9230	0.6	0.37	2.23	0.85	4.51	98.70	99.11	99.15	99.09	64	76.0	48.8	81.1	9480
1500	6.50	0.55	6.48	11.8	3750	8890	12640	0.6	0.35	2.22	0.81	4.48	98.86	99.21	99.23	99.16	65	77.6	49.0	87.6	11574
2000	6.50	0.47	6.48	13.8	4680	10250	14930	0.6	0.32	2.20	0.74	4.43	98.95	99.28	99.31	99.26	66	81.3	50.2	90.2	13779
2500	6.50	0.38	6.49	17.1	5990	9770	15760	0.6	0.25	2.14	0.61	4.34	98.95	99.33	99.39	99.37	68	90.0	51.2	94.9	17747

* Meets DOE 2016/NRCAN 2019 Energy Efficiency Regulation for Medium-voltage dry-type distribution transformer
 1) At a reference temperature of 75 °C

Installation and operating conditions

“Pre-inspection and regular maintenance are essential to maximize the lifespan and efficiency of the product. Follow the recommended instructions below for basic maintenance of the cast resin transformer.”

Checkpoints when installing cast resin transformers

Installation condition

- The installation location must be clean and free from flooding or dripping water from the ceiling.
- Ensure the installation location has adequate ventilation to dissipate heat generated by the transformer.

Checking of cast resin transformers in long-term storage

- If dust has accumulated during long-term storage, remove it using a vacuum cleaner or compressed air, and wipe the surface with a dry cloth.

Vinyl packing, which protects against foreign objects such as dust, screws, nuts, and washers, shall be kept in place until the transformer is energized after installation.

Torque values for connection with low voltage terminals

Bolt	M8	M10	M12	M16
Torque	125	250	405	1500

Unit: kgf·cm

Caution when connecting the terminals

When connecting cables or bus-bars to the HV and LV terminals, avoid applying mechanical stress to the terminals. Use flexible bus-bars to reduce stress caused by transformer vibration. Directly connecting bus-bars to the HV and LV terminals may loosen connection components or generate abnormal noise during operation due to transformer vibration.

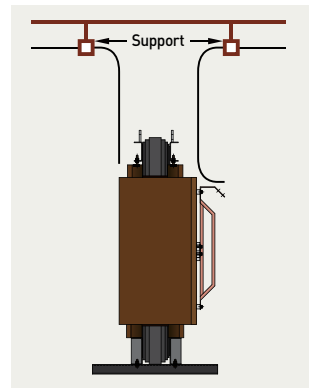

Top cabling

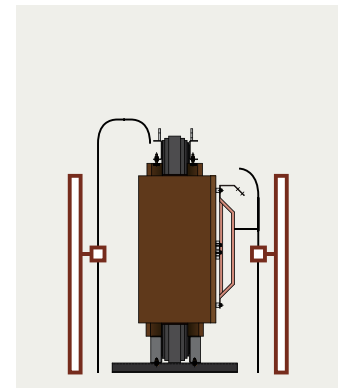

Bottom cabling

How to minimize transformer noise during installation

- Install rubber cushions under the bottom frame.
- Keep transformers separated from enclosures during installation to minimize vibration.
- Use flexible bus-bars when connecting terminals.
- Ensure transformer installation locations are rigid and level.
- Install large-capacity transformers near building pillars to reduce vibration.
- Avoid installing transformers near wall corners.
- Install non-flammable, sound-absorbing materials inside panels if necessary.

Considerations for ventilation

Vent Height and Area

- For natural cooling, the enclosure ventilation shall dissipate the transformer's total heat loss through natural convection.
- Proper ventilation is achieved by cold air entering through inlet A and hot air exiting through outlet A' at height H.

Forced ventilation

- When the average ambient temperature is higher than 68 °F (20 °C) or the transformer is often operated in an overload condition, forced ventilation using fans is necessary if the vent area is less than the standard.

$$A = \frac{HL}{0.1 \sqrt{H \Delta \theta a^3}} \text{ (m}^2\text{)}$$

$$A' > A \text{ 110\% (min.)}$$

A: Required inlet area (m²)
 A': Required outlet area (m²)
 Δθa: Air temperature rise (K) = 15K (Approximate value)
 HL: Heat loss (kW)
 H: Distance from the center of the outlet and the center of the TR (m)

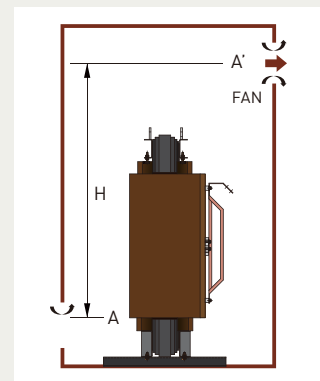
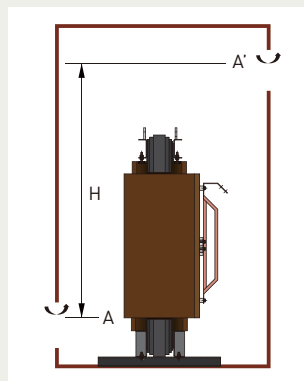

Minimum insulation distance

- Epoxy resin surface
- Ground
- Insulation-reinforced inter-phase lead surface
- Insulation cable

Checkpoints before receiving power

- Remove the vinyl packing cover and inspect the wiring condition, isolation distances, foreign material residues, component damage, bolt torque, and other relevant items.
- Compare the inter-phase connections of the cast resin transformer with the vector diagram on the nameplate.
- Measure insulation resistance using a 1000 V DC insulation tester (Megger).

Highest voltage (kV)	BIL (kV)	Minimum clearance (inch/mm)	
		Active – Earthed	Surface of epoxy resin – Earthed
≤1.1	-		0.39/10
3.6	40	2.36/60	1.96/50
7.2	60	3.54/90	1.96/50
12	75	4.72/120	2.95/75
17.5	95	6.29/160	3.93/100
24	125	9.84/250	5.90/150
36	170	13.77/350	7.87/200

Maintenance/Repair

Environment for general use

Remove dust using a vacuum cleaner and blow out the over-accumulated dust using a dray compressor every year. The cleaning period can differ depending on the use environment. During maintenance work, check the bolt mounting conditions using a torque wrench.

How to request after-sales service

If after-sales service is required, provide the transformer's nameplate serial number and a detailed description of the issue to ensure prompt and proper support.

Global Business



LS ELECTRIC set a mid- to long-term vision for each overseas market to broaden its global business presence. In addition to pursuing the evolution of our existing businesses, we are discovering new business opportunities and strengthening the basis of business operations to take a tailor-made approach to each local market.

<p>1 Europe</p> <p>Accelerating growth mainly in the renewable energy market</p>	<p>2 Middle East & Southwest Asia</p> <p>Strengthening direct sales through localization</p>	<p>3 China</p> <p>Strengthening business capabilities for power equipment and systems</p>
<p>4 Southeast Asia</p> <p>Focusing on the sale of strategic products and project development</p>	<p>5 North America</p> <p>Delivering global products and solutions, tapping into the Central and Latin American markets</p>	

► R&D



R&D Campus

Focuses on gaining competitive advantages through development of next generation platforms



Automation R&D Center

Serves as the main research institute for LS ELECTRIC

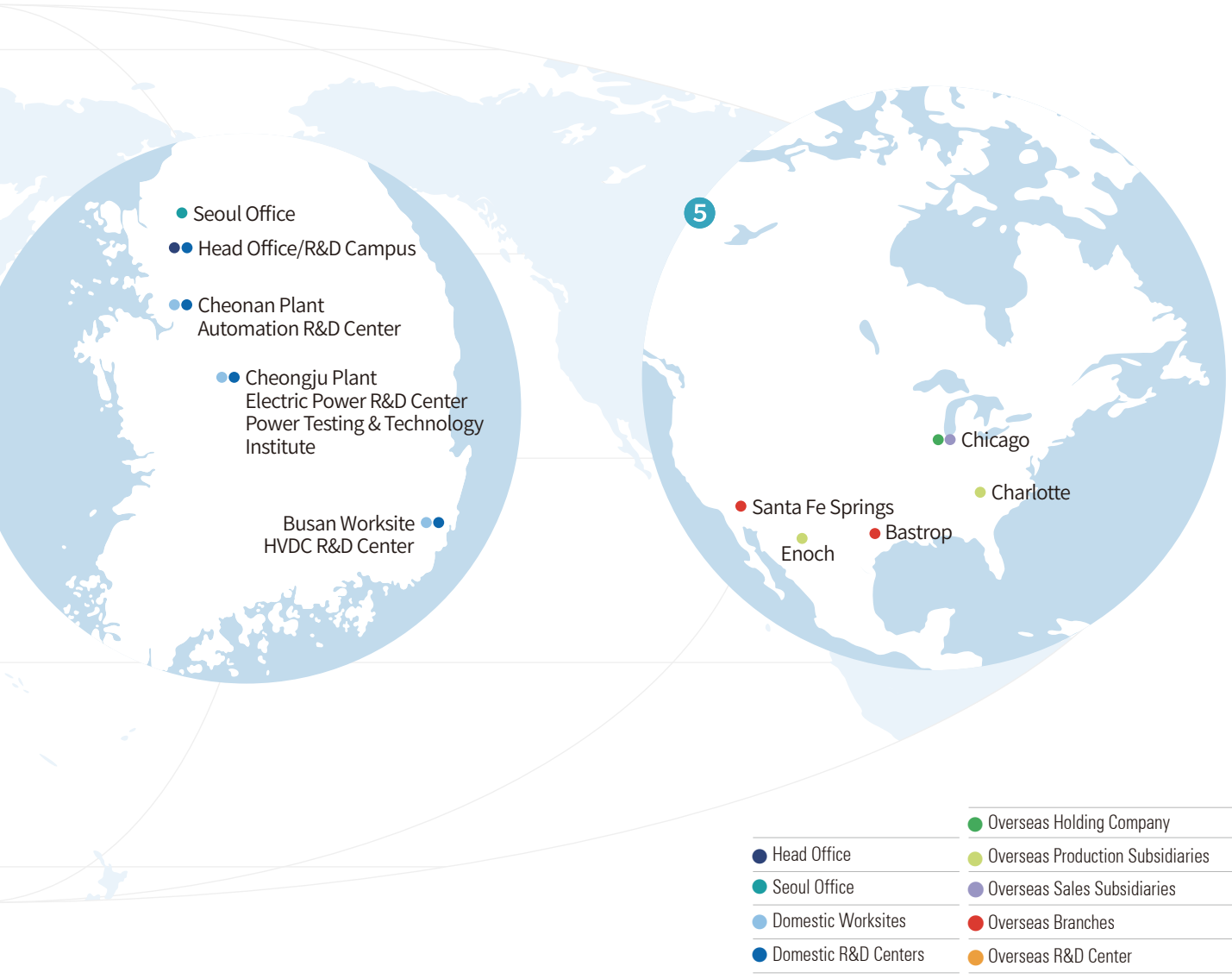

► **Factory**



Power Device R&D Center
Leading technology in electric industry and continuously developing future-growth dynamic engines



Cheongju Factory (Korea)
Electric Products, Mold TR, MV/LV Switchgear, and HV GIS



Cheonan Factory (Korea)
PLC, AC Drive, HMI, DCS, and PV Module



Busan Factory (Korea)
HV TR, HVDC, and FACTS



Ulsan Factory (Korea, LS Power Solution)
HV TR, Mold TR, and Pad TR



PT&T (Testing laboratory)
Internationally-renowned testing center that has formed partnerships with UL, CE, KEMA, and CESI



Wuxi Factory (China)
Electric Products



Dalian Factory (China)
MV/LV Switchgear, and MV Contactor



Hanoi Factory (Vietnam)
MV/LV Switchgear, and Mold TR



Tangerang Factory (Indonesia)
Pad TR, Distribution Oil TR, and Distribution Panel

**LS ELECTRIC America Inc. Chicago Head Office**

625 Heathrow Dr, Lincolnshire, IL 60069, USA

Tel. 1-800-891-2941 E-Mail: sales.us@lselectricamerica.com

Headquarter

127 LS-ro (Hogye-dong) Dongan-gu, Anyang-si, Gyeonggi-Do, 14119, Korea

Seoul Office

LS Yongsan Tower, 92, Hangang-daero, Yongsan-gu, Seoul, 04386, Korea

Tel. 82-2-2034-4916, 4684, 4429

China

LS ELECTRIC (Dalian) Co., Ltd.

+86-411-8730-5872

china.dalian@lselectric.com.cn

LS ELECTRIC (Wuxi) Co., Ltd.

+86-510-6851-6666

china.wuxi@lselectric.com.cn

LS ELECTRIC (Lishui) Co., Ltd.

+86-578-6866-780

china.lishui@lselectric.com.cn

Shanghai Office

+86-21-5237-9977

china@lselectric.com.cn

Beijing Office

+86-10-5095-1631

china@lselectric.com.cn

Guangzhou Office

+86-20-3818-2883

china@lselectric.com.cn

Qingdao Office

+86-532-8501-2065

china@lselectric.com.cn

Chengdu Office

+86-28-8670-3201

china@lselectric.com.cn

Nanjing Office

+86-25-84 67-0005

china@lselectric.com.cn

India

India Office

+91-80-6142-9108

Info_india@ls-electric.com

Indonesia

PT. LS ELECTRIC INDONESIA

+62-21-2933-7614

indonesia@ls-electric.com

Italy

Italy office

+39-030-8081-833

italia@ls-electric.com

Japan

LS ELECTRIC Japan Co., Ltd.

+81-3-6268-8241

japan@ls-electric.com

Tokyo Office

+81-3-6268-8241

tokyo@ls-electric.com

Netherlands

LS ELECTRIC Europe B.V.

+31-20-654-1424

europartner@ls-electric.com

Russia

Moscow Office

+7-499-682-6130

info@lselectric-ru.com

Singapore

Singapore Office

+65-6958-8162

singapore@ls-electric.com

Spain

LS ELECTRIC IBERIA S.L.U.

+34-910-28-02-74

iberia@ls-electric.com

Thailand

Bangkok Office

+66-2-128-0295

thailand@ls-electric.com

Türkiye

LS ELECTRIC Türkiye Co., Ltd.

+90-212-806-1252

turkiye@ls-electric.com

U.A.E.

LS ELECTRIC Middle East FZE (Dubai)

+971-4-886-5360

middleeast@ls-electric.com

USA

LS ELECTRIC America Inc.

+1-800-891-2941

sales.us@lselectricamerica.com

LS ENERGY SOLUTIONS LLC

+1-980-221-0654

info@ls-es.com

MCM Engineering II

+1-435-865-0125

sales.us@lselectricamerica.com

America Western Office

+1-949-333-3140

america@ls-electric.com

America Bastrop Campus

+1-800-891-2941 EXT 2

power_support.us@lselectricamerica.com

Vietnam

LS ELECTRIC Vietnam Co., Ltd.

+84-222-2221-110

vietnam@ls-electric.com

Hanoi Office

+84-24-6275-8054

vietnam@ls-electric.com

Ho Chi Minh Office

+84-3823-7890

vietnam@ls-electric.com

Specifications in this catalog are subject to change without notice due to continuous product development and improvement

© 2017. 11 LS ELECTRIC Co., Ltd. All rights reserved. English (02) 2026. 04 Human Power

www.LSElectricAmerica.com