



**Beyond**™

**Power Transformer**

**LS** ELECTRIC



## Growing as the World's Best from the Nation's First

The company serves its customers!

Leading company in the industrial electric, electronic, materials and energy field following its separation from LG in 2003. LS aims to develop into a company that provides its clients with total solutions, contributes to the overall society, and offers a business environment where

## Innovators in Industrial Electrical and Automation Systems

LS ELECTRIC goes toward a global leading company in the Industrial electric & Automation field, providing customers with the total solution. We provide customers with distinctive and eco-friendly products & Win-Win Strategy in the various fields such as Power Transmission & Distribution ; Electric Equipment ; Automation Equipment & Systems and Smart Grid.

# BeyondX™ Power Transformer



## Contents

LS ELECTRIC Power Transformer .....	04
Line-Up .....	06
Core .....	08
Coils and Windings .....	09
Magnetic Field Analysis .....	10
Insulation Analysis .....	11
Cooling System Analysis .....	12
Mechanical Structure Analysis .....	13
Process .....	14
Test .....	15
Definite Purpose High Voltage Transformer .....	16
Smart and Wide Area Combined Diagnosis System .....	18
PDPS (Power Equipment Diagnosis and Preventive System) .....	20
Quality Assurance .....	22
LS QIS (Quality Information System) .....	23
Check List .....	24
References .....	25
Global Business .....	26

# LS ELECTRIC Power Transformer

The power transformer is a static inductive device that steps voltage up and down to transfer electrical power effectively. Winding types and methods that offer the least loss were selected using magnetic field analysis and are used in LS ELECTRIC power transformers to ensure high efficiency. Moreover, by selecting the optimal insulating structure through electric field analysis of insulation between turns, sections, windings, and phases, electrical stability of the power transformer is achieved. LS ELECTRIC's advanced analysis technology has enabled the realization of an optimal cooling system, and 3D structural strength analysis has enabled a structural design that can withstand internal mechanical forces during short circuits caused by system faults, seismic conditions from external impacts, and the impact of transportation.

The LS ELECTRIC Power Transformer factory is equipped with the latest core processing machines, advanced winding machines, high-capacity vacuum heat drying equipment, state-of-the-art cleaning facilities, and the industry's best testing facility.



## **LS ELECTRIC is a new top-tier supplier in the power transformer market. This is why LS ELECTRIC continues to work longer and harder for you.**

As a leading company in Korea's power solutions industry, LS ELECTRIC plays a central role in the national power supply network, based on its reliability and technology. LS ELECTRIC's experience in transformer manufacturing and production technologies, spanning more than 20 years, has enabled us to proudly present power transformers that meet and exceed the current standards of the industry. LS ELECTRIC will instill confidence in customers through high-quality products.



### **Over 30 years of experience in electrical solutions (Since 1974)**

LS ELECTRIC has been focused on industrial electrical and electronics solutions for over 30 years. The company has achieved technological innovations and improved competitiveness through continuous R&D and investments.

### **Not only the latest, but also the newest technology!**

LS ELECTRIC Power Transformers do not merely possess the latest technologies. The state-of-the-art products are also equipped with the newest technologies. On top of all the merits that are part of existing systems, our power transformers provide a complete solution with a network control system for the benefit of private consumers, as well as commercial power plants.



### **Trust LS ELECTRIC transformers based on flawless performance**

Safety and reliability are critical in a power transformer. This is why you need to choose a reliable company for your transformer. LS ELECTRIC's Power Transformers ensure optimum reliability through stable performance in any given condition.

### **Strict testing makes reliable and safe products**

LS ELECTRIC's conviction that rigorous testing is the only way to ensure perfectly operational products at industrial sites has also been applied to power transformers. If you are concerned about reduced competitiveness caused by maintenance problems and defects, hesitate no more and choose LS ELECTRIC Power Transformers.



### **Professional staff with superior expertise make your project succeed**

LS ELECTRIC's top Korean engineers will lead you to success in your business with highly trained skills and careful management.

### **The latest facilities and equipment produce exceptional products**

LS ELECTRIC has constructed an ultra-modern factory in an effort to satisfy the diverse demands of its customers. Our clean facilities enable the production of zero-defect products, where even a single speck of dust is not allowed.



### **LS ELECTRIC always considers efficiency and the environment**

LS ELECTRIC considers the global environment in harmony with future-oriented technologies. We aim not only to provide economic advantages for our customers through increased energy efficiency, but also to fulfill our social responsibilities through the development of environmentally friendly products.

# Line-up

LS ELECTRIC's power transformers are produced on a clean, zero-defect production line, and come in capacities up to 550 kV, 800 MVA.

33 kV

69 kV

132 kV

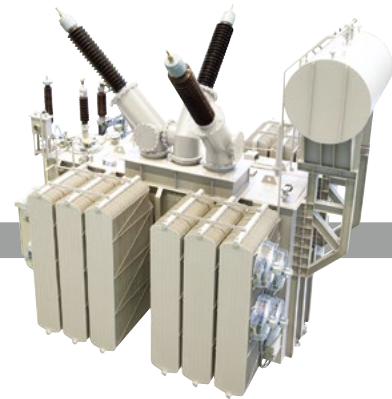

## Power Transformer up to 550 kV/800 MVA

Applicable Standard		IEC 60076/ANSI (IEEE) C57
Installation Location		Outdoor/Indoor
Frequency [Hz]		50/60
Insulation		Oil type
Insulation Class [°C]		A (105 °C)
Winding Temp. Rise [K]		65
Oil Temp. Rise [K]		60
Cooling Method	Internal	ON/OF/OD
	External	AN/AF/WF
Capacity (MVA)		Up to 800 for Three Phase
		Up to 500 for Single Phase

220 kV

400 kV

550 kV



Oil Preservation System	Conservator Type N <sub>2</sub> Sealing Type Air Seal Cell Type
Base	Skid, Roller
Insulation	Oil Type
Application	Generation Plant (GSU) Substation Transmission and Distribution
Special Purpose	Scott Connection Electric Furnace Shunt Reactor HVDC Converter Transformer

※ LS ELECTRIC produces and supplies products that conform to customer specifications as well as IEC and ANSI standards.



# Core

Non-aging grain-oriented silicon steel sheets with high permeability and low hysteresis loss are used in core construction. They are thinly laminated to reduce eddy current loss, and the joints are arranged in a step-lap configuration to reduce loss and noise.

The thin silicon steel sheets produced by the core manufacturing equipment are stacked to form magnetic circuits that can generate magnetic flux. The stacking process cannot be carried out in an upright position due to the thin and large size of the silicon steel sheets. Therefore, the process is instead carried out horizontally on a stand. Upon completion of the stacking process, the top and bottom of the core are supported by frame tie plates. Glass resin tape is wound securely around the core, after which it is stood upright.

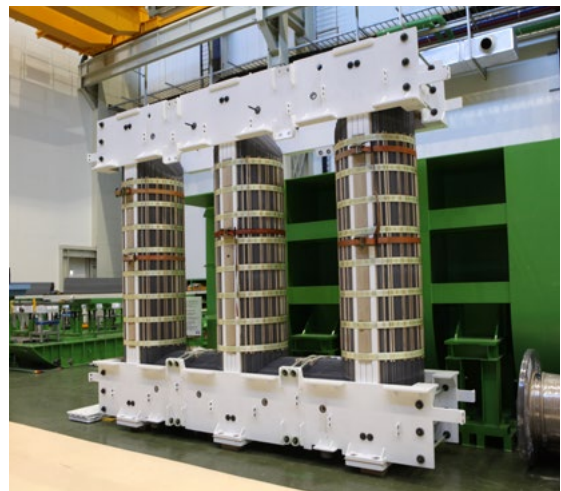

## Coils and Windings

Coils and windings prevent insulation damage caused by contraction and expansion during temperature changes, and variation and bending caused by severe abnormal conditions.

The windings are produced by winding pure copper coils of at least 99.9% purity around a circular winding machine. The winding machines are separated into vertical and horizontal types. The vertical type is used for high-voltage, low-current applications with a small number of conductors and implements a complex winding method. The horizontal type is used for low-voltage, high-current applications with a large number of conductors. Winding processes are carried out in a dust-free room to protect the windings from harmful particles.



# Magnetic Field Analysis

Magnetic fields can be calculated using 3D magnetic field analysis, as well as stray losses in structures inside the magnetic field such as the tank and frame, and hot spot temperatures.

## Eddy Current Loss Minimization

A Magnetic field analysis is used to minimize eddy current losses that occur in conductors due to magnetic flux. At the ends of the windings, magnetic flux in the horizontal components is high. In the central parts of the winding, magnetic flux in vertical components is high. Conductor sizes are optimized accordingly to minimize eddy current losses.

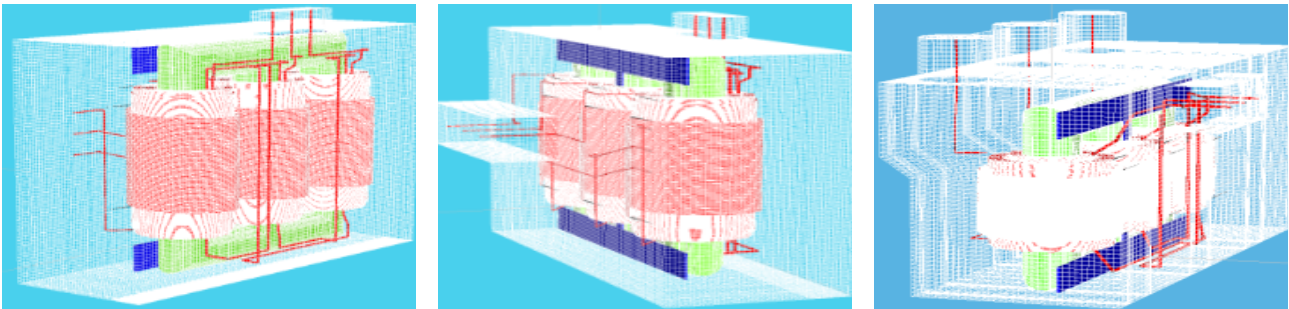

## Frame Temperature Rise/Tie Plate Temperature Rise

At the design stage, the distribution of magnetic flux leakage in the core-supporting frame and the leg coresupporting tie plate is analyzed using 3D modeling.

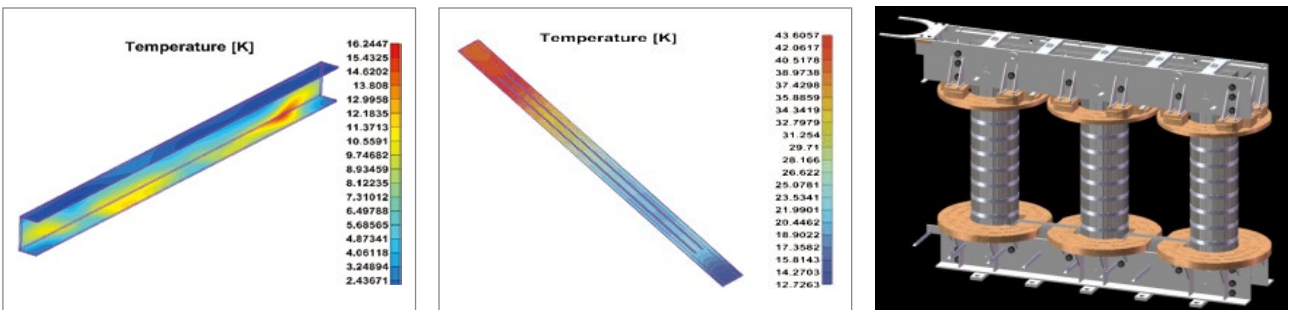

## 3D Magnetic Field Analysis

Losses in structures such as the frame or tank caused by magnetic flux leakage are estimated using 3D magnetic field analysis software. Based on the analysis results, adjustments are made to the frame structure and dimensions, and magnetic shielding such as magnetic shunts is attached to the interior walls to minimize losses and temperature rise.

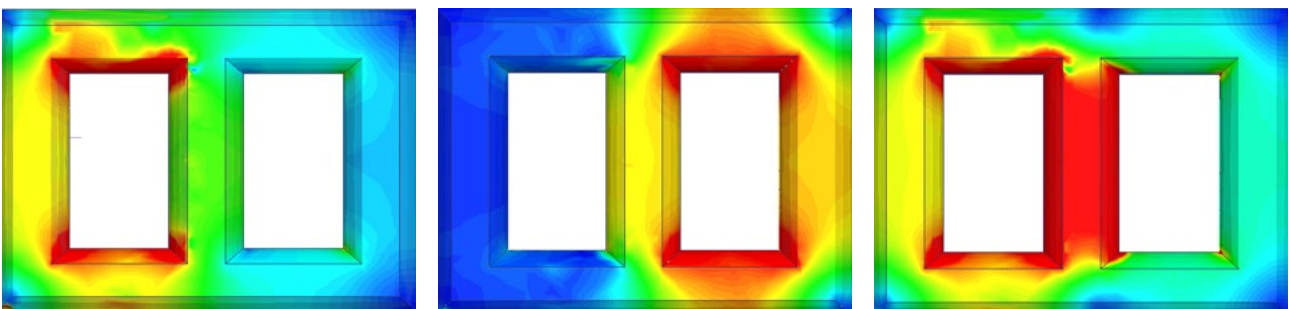

# Insulation Analysis

Transient analysis software is used to analyze the transient state when impulse voltages are applied, and to analyze the insulation strength between turns, sections, and windings. An electric field analysis program is used to analyze the insulation strength at the main gap in the center of the windings and at the end of the windings.

## Transient Stage Voltage Oscillation

Using results from a transient voltage analysis program, the insulation strength between specific sections, electrodes, and nodes is examined. By measuring the concentrated electric field in the insulating materials at the middle and end of the windings, it is possible to verify whether the insulating structure meets the required insulation standards. The results are used to determine the size and number of the insulating barrier's oil gaps, and whether angle rings should be inserted. At the ends where electric fields are concentrated, a static shield ring is inserted to relieve the electric field. The series capacitance is increased to improve excessive voltage characteristics, resulting in a safe and compact insulating structure.

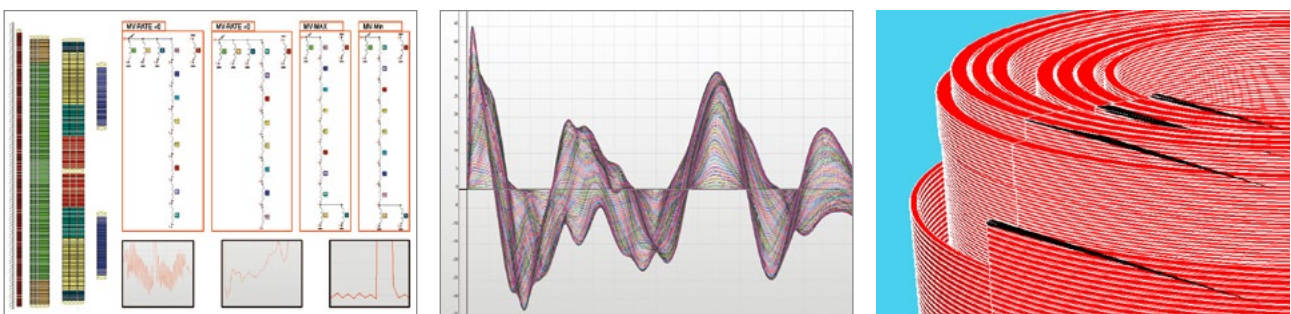

## Electric Field Analysis

To guarantee the transformer's electrical safety margin, electric field analysis is carried out. The LS ELECTRIC design software can replicate several possible conditions that may arise if the winding is subjected to basic lightning impulses, chopped-wave impulses, and switching impulses. The winding's inductance, resistance, and capacitance, together with the electric field of the nodes that are distributed along the windings, can be tested using such conditions. Analysis results are used to design electrically safe devices by inserting contra shields at the winding ends to relieve the electric field and by using interleaved windings. Where electric fields are concentrated, a static shield ring is inserted to relieve the electrical stress. The series capacitance is increased to improve excessive voltage characteristics, resulting in a safe and compact insulating structure.

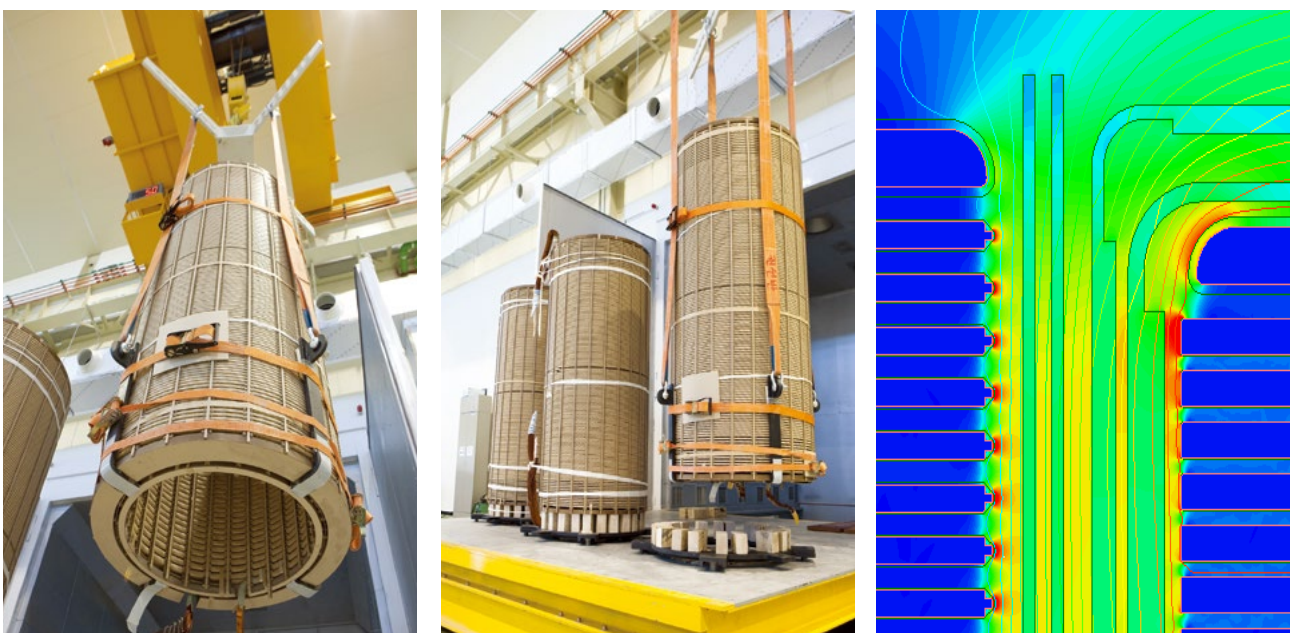

# Cooling System Analysis

The cores and the windings are designed for optimal cooling efficiency. They are designed with large heat-radiating surface areas. Some are equipped with fans and pumps for forced cooling. A program capable of applying various parameters, such as radiator surface areas, coolant types, and the size and quantity of fans and pumps, is used for verification.

## Heat Analysis

Losses that occur in structures such as the frame or the tank, caused by leakage of magnetic flux are estimated using the 3D magnetic field analysis program. Adjustments based on the analysis results are made to the frame's structure and dimensions, and magnetic covers, such as magnetic shunts, are attached to interior walls to minimize losses and temperature rise.

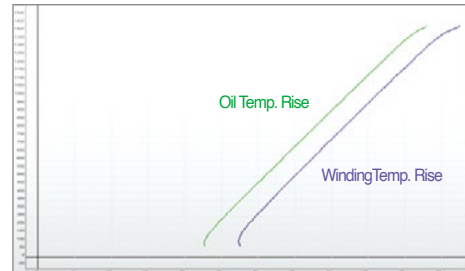
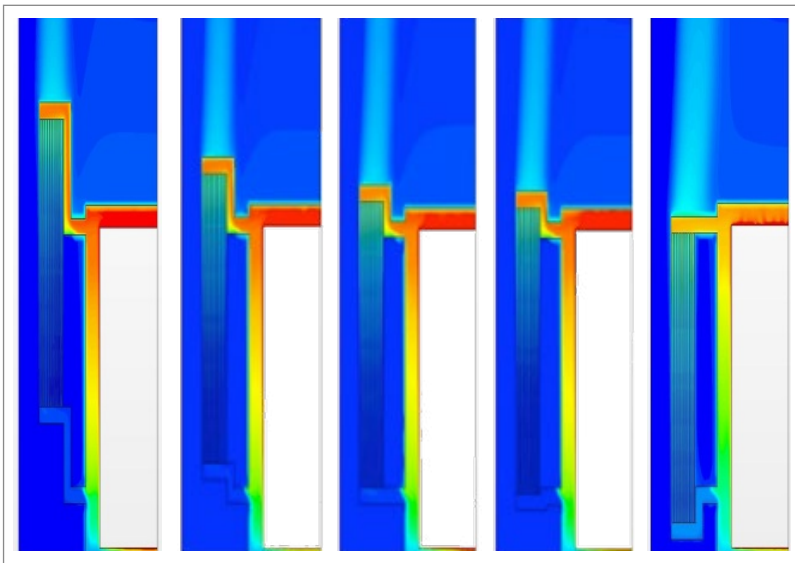

Distribution of temperatures in coils. Concenter HW, Mode HVIRAT						
Number of coil	Type of coil	Coordinate of the coil center relative to the lower yoke, mm	Heat flow density, W/m <sup>2</sup>	Average coil temperature rise over cooling in the tank, K	Average coil temperature rise over cooling medium temperature, K	Hottest spot temperature rise over cooling medium temperature, K
1	E	1432.868	876.335	18.03207	57.4577	61.30491
2	E	1385.839	853.9028	17.76387	56.79533	60.82418
3	E	1368.91	844.0848	17.69041	56.28529	60.1984
4	E	1361.781	837.8813	17.59568	55.79969	59.73536
5	E	1334.751	833.819	17.54939	55.35953	59.30362
6	E	1317.723	831.04	17.53042	54.93668	58.89472
7	E	1300.693	829.0421	17.52197	54.52435	58.49849
8	E	1293.665	827.5252	17.52004	54.11955	58.09999
9	E	1286.636	826.3066	17.5222	53.71684	57.69944
10	E	1289.607	826.2726	17.52893	53.31768	57.29177
11	E	1232.578	824.3617	17.53326	52.92014	56.89627
12	E	1215.548	823.4989	17.54059	52.52361	56.50154
13	E	1198.52	822.685	17.54854	52.12768	56.10728
14	E	1181.49	821.8613	17.55686	51.73315	55.71381

Hottest spots in relation to Temperature Rise





# Process



## Winding

The process for manufacturing a cylindrical coil involves winding rectangular copper wire (purity over 99.999%) onto a cylindrical winding mandrel.



## Core Cutting and Punching

Cores are produced by automatically cutting and punching rolled silicon steel sheets to designed sizes using automated equipment.



## Core Stacking and Assembly

The cut silicon steel sheets are stacked to form a magnetic circuits capable of generating magnetic flux.



## Assembling the Main Body

Core and windings are combined electromagnetically.



## Final Assembly

Once the main device is inserted into the tank and vacuum is achieved, the formation of electrical circuit is completed by filling with insulation fluid and installing various supplementary equipment types on the tank exterior.



## Final Testing

Upon completion of final assembly, the transformer's electrical characteristics and insulation performance are verified through final testing to ensure the highest level of quality.

# Test

We possess reliable, world-class testing and measuring equipment, and a system that provides our customers with products of the highest quality. Characteristic tests, insulation tests, and temperature rise tests are conducted in accordance with international standards such as IEC, ANSI/IEEE, NEMA, KS, and ES.

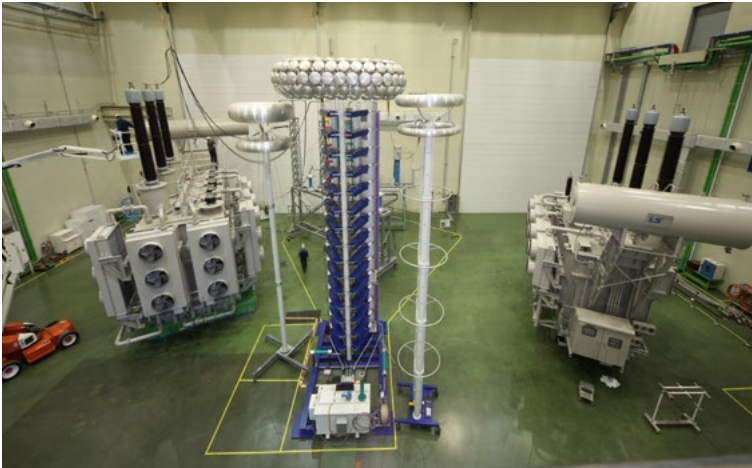

## Routine tests

- a) Measurement of winding resistance
- b) Measurement of voltage ratio and phase displacement check
- c) Measurement of short-circuit impedance and load loss
- d) Measurement of no-load loss and current
- e) Dielectric routine tests

## Type tests

- a) Temperature rise test
- b) Dielectric type tests
- c) On-load tap changer tests



## Special tests

- a) Dielectric special tests
- b) Determination of capacitances related to windings-to-earth, and between windings
- c) Determination of transient voltage transfer characteristics
- d) Measurement of zero-sequence impedance(s)
- e) Determination of sound levels
- f) Measurement of no-load current harmonics
- g) Measurement of fan and oil pump motor power consumption
- h) Measurement of insulation resistance



## Testing Equipment

Impulse Test	3000 kV 300 kJ
AC Withstand Voltage Test	600 kV 3000 kVA
P.D. Measurement	ERA/RIV 20 kHz – 20 MHz
M.G. Set	6.6 kV 2400 kVA
Loss Measurement	200 kV 4000 A
Resistance Measurement	100 A, 1 μΩ – 500 Ω
Condenser Bank	130 kV 144 MVAR



# Definite Purpose High Voltage Transformer

## Converter Transformer

This is a special transformer used in high-voltage DC (HVDC) transmission systems that converts an existing high-voltage AC (HVAC) transmission system to a HVDC transmission system.

The HVDC system is a high value-added power transmission system that can be used for long-distance power transmission, cable power transmission, asynchronous AC grid connection, grid separation, and large-scale renewable energy grid connection. Converter Transformers (C-TRs) are essential components in this system.

HVDC C-TRs are designed and manufactured using advanced technology, considering electrical and mechanical characteristics such as DC stress, polarity reversal stress, harmonic losses, insulation design and structural design of valve bushings, and cooling design as well as existing AC transformer design elements.



## Static VAR Compensator Transformer

SVC (Static VAR Compensator) transformers serve as core equipment in stationary reactive power compensators, which improve power quality and system stability by supplying or absorbing reactive power in the AC transmission system.

SVC transformers connect the Thyristor Switched Capacitor (TSC) and Thyristor Controlled Reactor (TCR) to the high-voltage transmission system to compensate for reactive power.

While similar to general-purpose transformers, SVC transformers are special-purpose transformers designed for continuous operation at maximum and minimum reactive power compensation points.

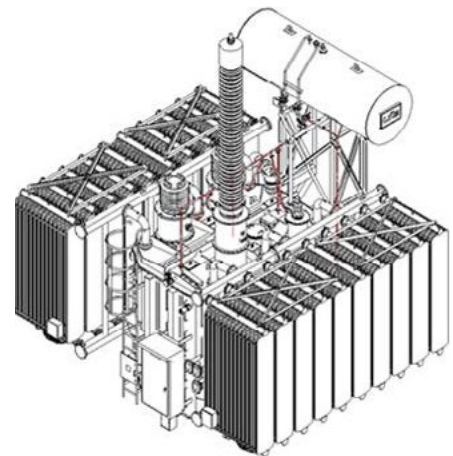

## Scott Transformer

The Scott transformer is a special transformer that converts three-phase power (120° phase difference) to two-phase power (90° phase difference).

This transformer is used for special applications such as supplying a large-capacity single-phase load as a three-phase power supply. In Korea, it is mainly used for railway power supply, where three-phase power is converted to two phases and divided into upper and lower lines.

In contrast to conventional Scott transformers consisting of two active parts, LS ELECTRIC transformers can be configured with one active part, which offers advantages such as compact size, reduced weight, and competitive pricing.



## Mobile Transformer



Compact type mobile transformers that can be trailer-mounted are available. Mobile substations offer superior mobility and system flexibility compared to conventional substations and are the ideal solutions for emergency power supply in areas experiencing power outage or for isolated power supply.

# Smart and Wide Area Combined Diagnosis System

By regularly monitoring major power equipment, potential accidents can be prevented. A database system that records events and history for each unit enables efficient management of power equipment.

**CMS**  
Centralized  
Management System

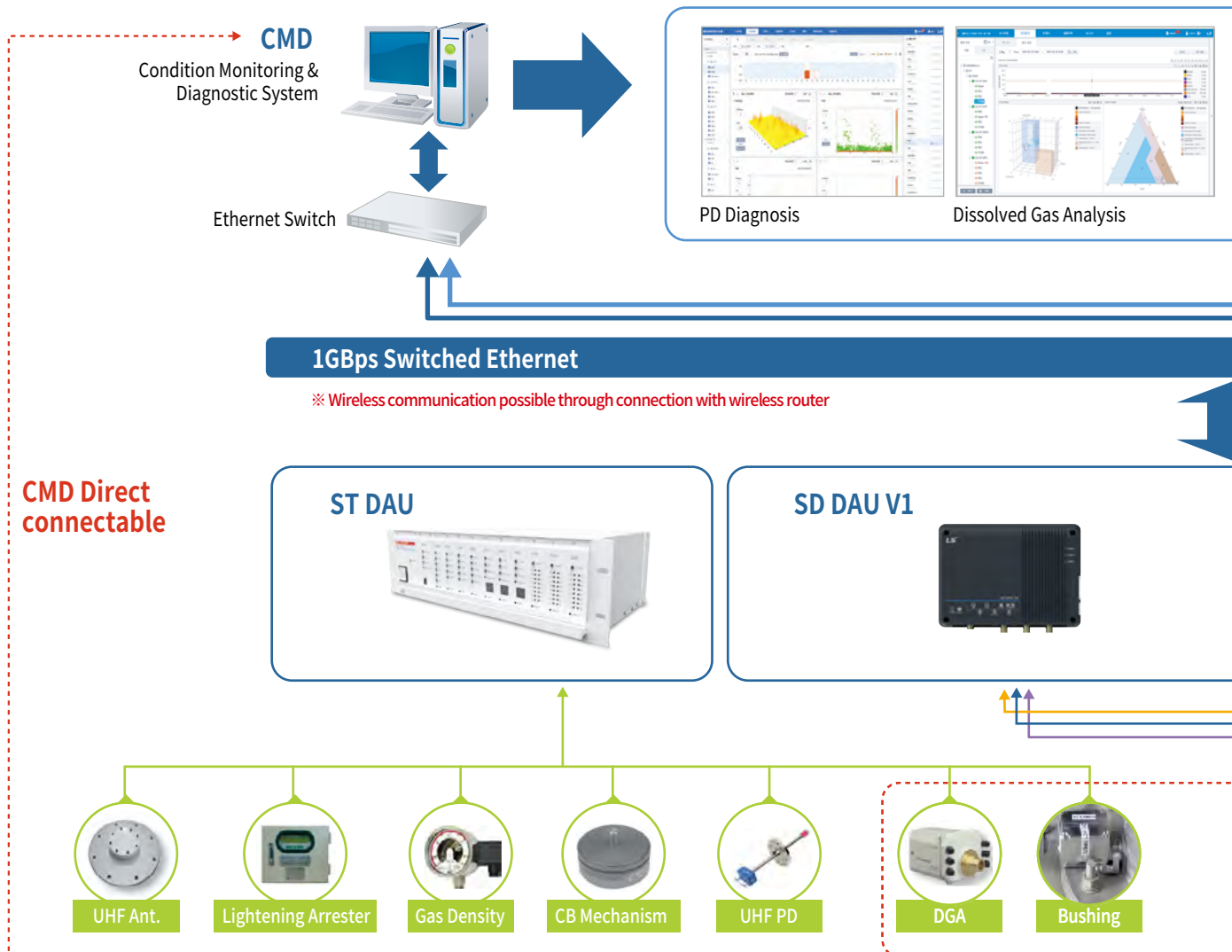

**HV GIS Diagnosis**

- Partial Discharge (UHF PD)
- Lightening Arrest
- Gas Density
- CB Operating / Contact Life

**HVTr. Diagnosis**

- Dissolved Gas
- Partial Discharge (UHF)
- Bushing PD
- OLTC
- WTI, OTI

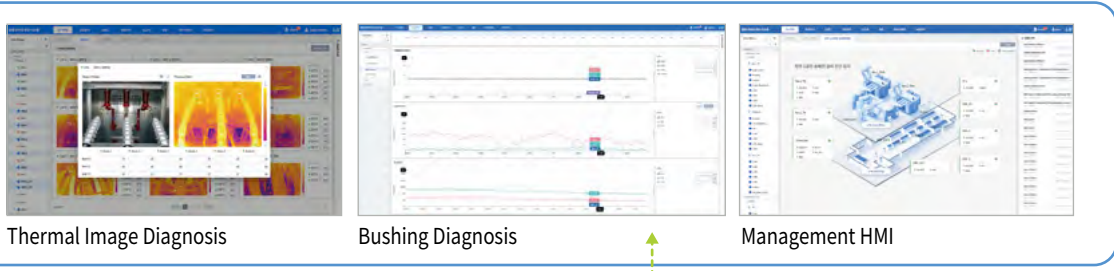

SD DAU V2



SD DAU V3



**TEV (Transient Earth Voltage) :**  
Measurement of PD signal flowing on the grounded surface

**AA (Airborne Acoustic) :**  
Non-contact sensor, detection of sound or vibration wave in the ultrasonic field transmitted into the air

**AE (Acoustic Emission) :**  
Contact sensor, transmitted through the surface of the enclosure of power equipment

**Switchgear, Mold Tr. Diagnosis**

- Partial Discharge
  - UHF Ant.
  - HFCT / TEV
  - AA / AE
- Temp (Thermal Image)



# PDPS (Power Equipment Diagnosis and Preventive System)

## Major Monitoring and Supporting Report

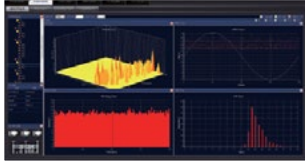

### GIS PD Diagnosis HMI

- Improved reliability using neural networks and fuzzy algorithms
- Visual diagnostic function with 2D/3D chart
- PD Pattern analysis based on sensor and event filtering

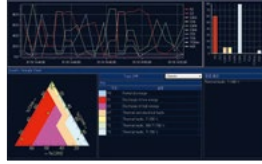

### TR Multi-Gas Diagnosis HMI

- TR degradation diagnosis using gas density
- Easy data input
- Quick assessment upon entering gas concentration

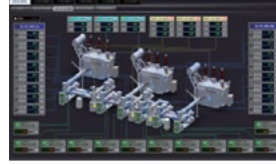

### GIS and TR Diagnosis HMI

- GIS partial discharge
- GIS gas density
- Lightning leakage monitoring
- TR oil-dissolved gas analysis
- Abnormal temperature(oil/coil) monitoring
- TR.fan group (operating current/time)
- OLTC (operating current/time)

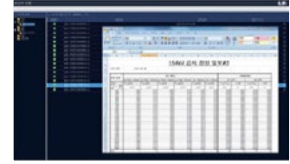

### Total Diagnosis and Report

- Diagnosis by sensor and time period
- Day/Month/Year trend analysis
- Max/Min/Average statistics by period
- Provides trend data scaling ( expansion/reduction)
- Excel report export

## Circuit Breaker (CB) Mechanical Operating Diagnosis



### CB Operating Diagnosis HMI

- CB operating assessment and specific wave
- CB interrupter contact life



- Gas density
- Oil motor
- Saving and management of the CB operating

## TR Duval Triangle/Dissolved Gas Analysis

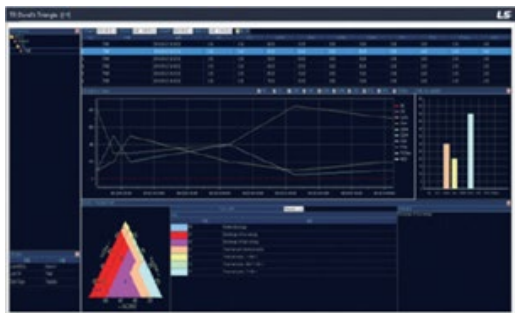

### TR Multi-Gas Diagnosis HMI

- TR degradation diagnosis function using gas density
- Easy to input data



- Quick assessment upon entering the gas concentration

### PD Data Diagnosis Using Neural Network/ Fuzzy Algorithm



**GIS PD Diagnosis HMI**

- Improved reliability using Neural Network and Fuzzy Algorithm
- Visual diagnostic function with 2D/3D chart
- PD Pattern analysis based on sensor data and event filtering

### Multi Channel PD Diagnosis

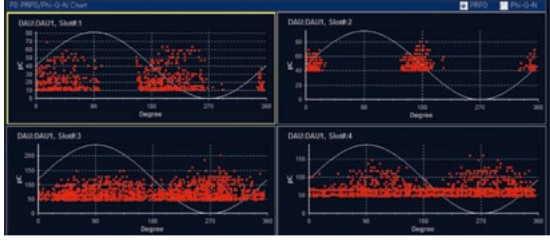

### Switchgear/Mold TR Diagnosis

**Switchgear HMI**



**Mold TR HMI**



**Neural Network/Fuzzy Algorithm**



**Temperature Trend and Library**



# Quality Assurance

Flexible and quick delivery is possible through our computerized management using an ERP system and rigorous ISO 9001 quality control. Moreover, we have obtained ISO 14001 environmental management system certification for our environmentally friendly production and after-sales service.

## Quality Management

LS ELECTRIC operates a development facility that conducts verifications under various conditions and comparison tests with other companies' products. This achieves increased customer satisfaction through high-quality products. Such quality management has earned LS ELECTRIC many certifications and awards, and has become the basis for realizing products that meet global standards.

## Customer Technology Training Service

LS ELECTRIC offers industry-leading customer training programs through the internal training institute. Factory automation and other industrial electrical and electronic processes are taught through hands-on practice apparatus. Technical advice and guidance are offered through these cutting-edge technological services.

## Web-Based Customer Service

LS ELECTRIC offers global web-based customer service, aimed at customer satisfaction by providing technical information, quick responses to inquiries, and accurate service history. Moreover, by building a supply chain management system with integrated management for purchasing, production, and supply, we are leading e-business aspects of industrial electrical automation.

**KSA**  
ISO 9001/14001 CERTIFIED  
K-OHSMS 18001

**PT&T**

**KERI**





**PT&T** | Power Testing & Technology

PT&T is a KOLAS-qualified (Korea Laboratory Accreditation Scheme) accredited testing laboratory and provides worldwide testing services with its 1,600MVA-capacity high-power laboratory, high voltage laboratory, and reliability testing laboratory.

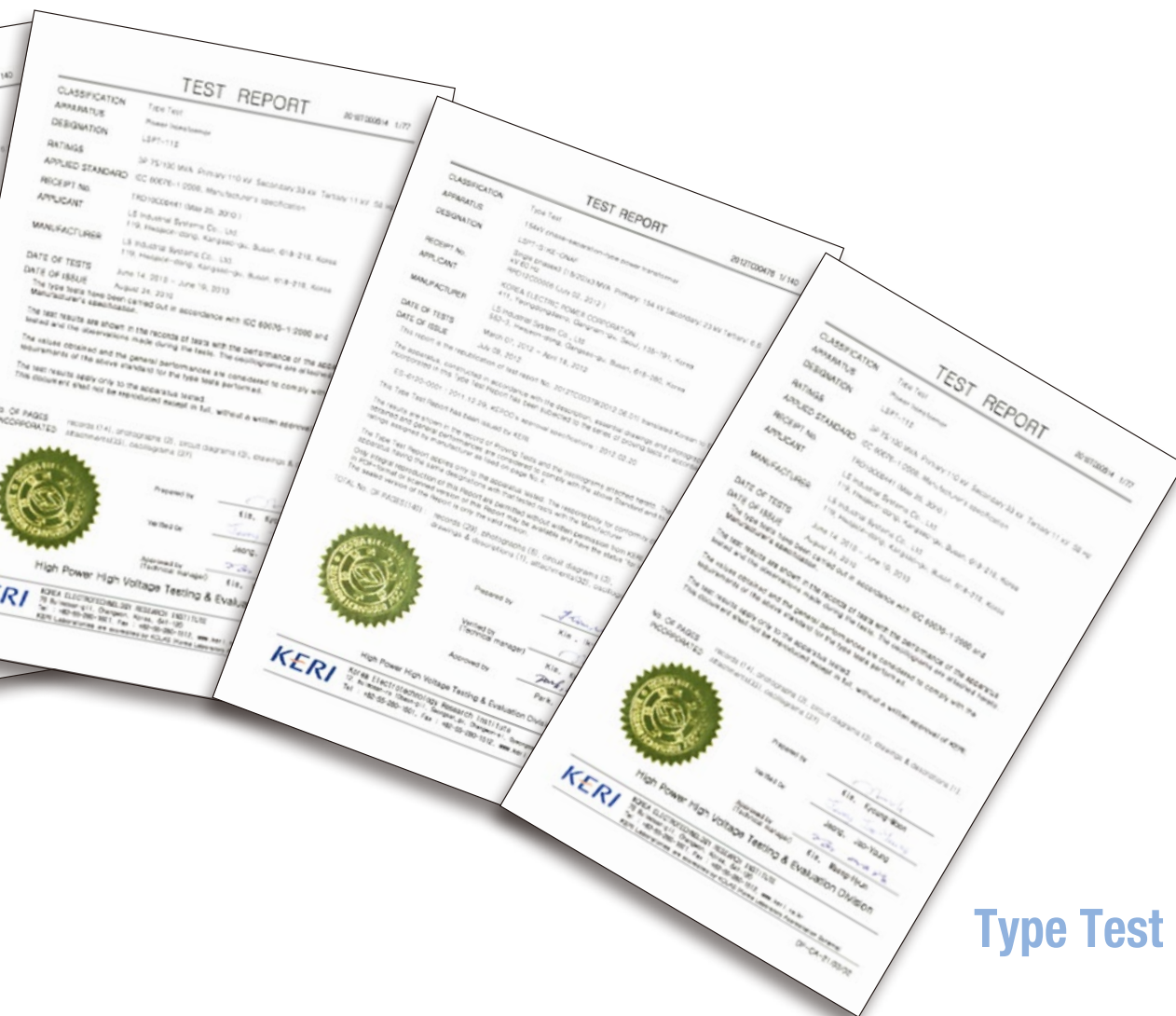

**Type Test Report**

# Check List

Item	Content			
Applicable Standard	<input type="checkbox"/> IEC	<input type="checkbox"/> ANSI	<input type="checkbox"/> etc	
Phase	<input type="checkbox"/> single-phase	<input type="checkbox"/> three-phase	<input type="checkbox"/> etc	
Place of Installation	<input type="checkbox"/> indoor	<input type="checkbox"/> outdoor		
Loading	<input type="checkbox"/> general load	<input type="checkbox"/> etc		
Condition of Installation	<input type="checkbox"/> new installation	<input type="checkbox"/> extension	<input type="checkbox"/> parallel operation	
Frequency	<input type="checkbox"/> 50Hz	<input type="checkbox"/> 60Hz		
Cooling Type	<input type="checkbox"/> ONAN	<input type="checkbox"/> ONAF	<input type="checkbox"/> etc	
Capacity	<input type="checkbox"/>	/	/	
Rated Voltage	<input type="checkbox"/> Primary kV	<input type="checkbox"/> Secondary kV	<input type="checkbox"/> kV	
Tap Changer	<input type="checkbox"/> DETC	<input type="checkbox"/> OLTC	<input type="checkbox"/> etc	
Tap Range	<input type="checkbox"/>			
Earthing Method	<input type="checkbox"/> direct	<input type="checkbox"/> resistance	<input type="checkbox"/> arrester	<input type="checkbox"/> etc
Connection	<input type="checkbox"/> Y-D	<input type="checkbox"/> D-Y	<input type="checkbox"/> D-D	<input type="checkbox"/> etc
Winding / Oil Temp rise	<input type="checkbox"/> winding	<input type="checkbox"/> oil		
Impedance	<input type="checkbox"/> %			
	<input type="checkbox"/> top-top	<input type="checkbox"/> top-side	<input type="checkbox"/> side-top	<input type="checkbox"/> side-side
Bushing Withdraw	<input type="checkbox"/> etc			
Additional Demand Item	<input type="checkbox"/>			
Painting	<input type="checkbox"/> LS standard	<input type="checkbox"/> etc		
Notes	<input type="checkbox"/>			

# References



## Republic of Korea

- Dangjin Unit 4: 3-phase, 345/18.05 kV, 616.5/690 MVA
- Sinseocheon: 1-phase, 154 kV, 403 MVA
- Samsung Electronics: 3-phase, 154kV, 45 MVA (Ester Oil)
- BukBusan/Shinyangsan: STATCOM, 1-phase, 345 kV, 167 MVA
- BukDangjin - Godeok, HVDC CTR: 1-phase, 345/220 kV (±500 kV) Y-Y, 31.5 MVA



## United States

- Atlas BESS GSUT, 3-phase, 525 kV, 425 MVA
- WAPA, 3-phase, 230 kV, 250 MVA
- RWE, 3-phase, 138 kV, 250 MVA
- Vanderbilt, 3-phase, 69 kV, 112 MVA (Ester Oil)
- Ford Essex, 3-phase, 115 kV, 46.7 MVA
- Samsung Engineering, 3-phase, 138 kV, 80 MVA



## China

LG Display: 3-phase, 220 kV, 100 MVA



## Brazil

CSP: 3-phase, 138 kV, 50 MVA



## Iraq

- MOE Mobile: 3-phase, 132 kV, 25 MVA
- MOE: 1-phase, 400 kV, 83.3 MVA
- MOE: 3-phase, 33 kV; 31.5 MVA, 132 kV 63 and 90 MVA



## Ecuador

CELEC EP: 3-phase, 230 kV, 167 MVA



## India

POSCO: 3-phase, 220 kV, 75 MVA



## Chile

Abengoa: 3-phase, 220 kV, 110 MVA

# Global Business



LS ELECTRIC set a mid- to long-term vision for each overseas market to broaden its global business presence. In addition to pursuing the evolution of our existing businesses, we are discovering new business opportunities and strengthening the basis of business operations to take a tailor-made approach to each local market.

## 1 Europe

Accelerating growth mainly in the renewable energy market

## 2 Middle East & Southwest Asia

Strengthening direct sales through localization

## 3 China

Strengthening business capabilities for power equipment and systems

## 4 Southeast Asia

Focusing on the sale of strategic products and project development

## 5 North America

Delivering global products and solutions, tapping into the Central and Latin American markets

## R&D



### R&D Campus

Focuses on gaining competitive advantages through development of next generation platforms



### Automation R&D Center

Serves as the main research institute for LS ELECTRIC

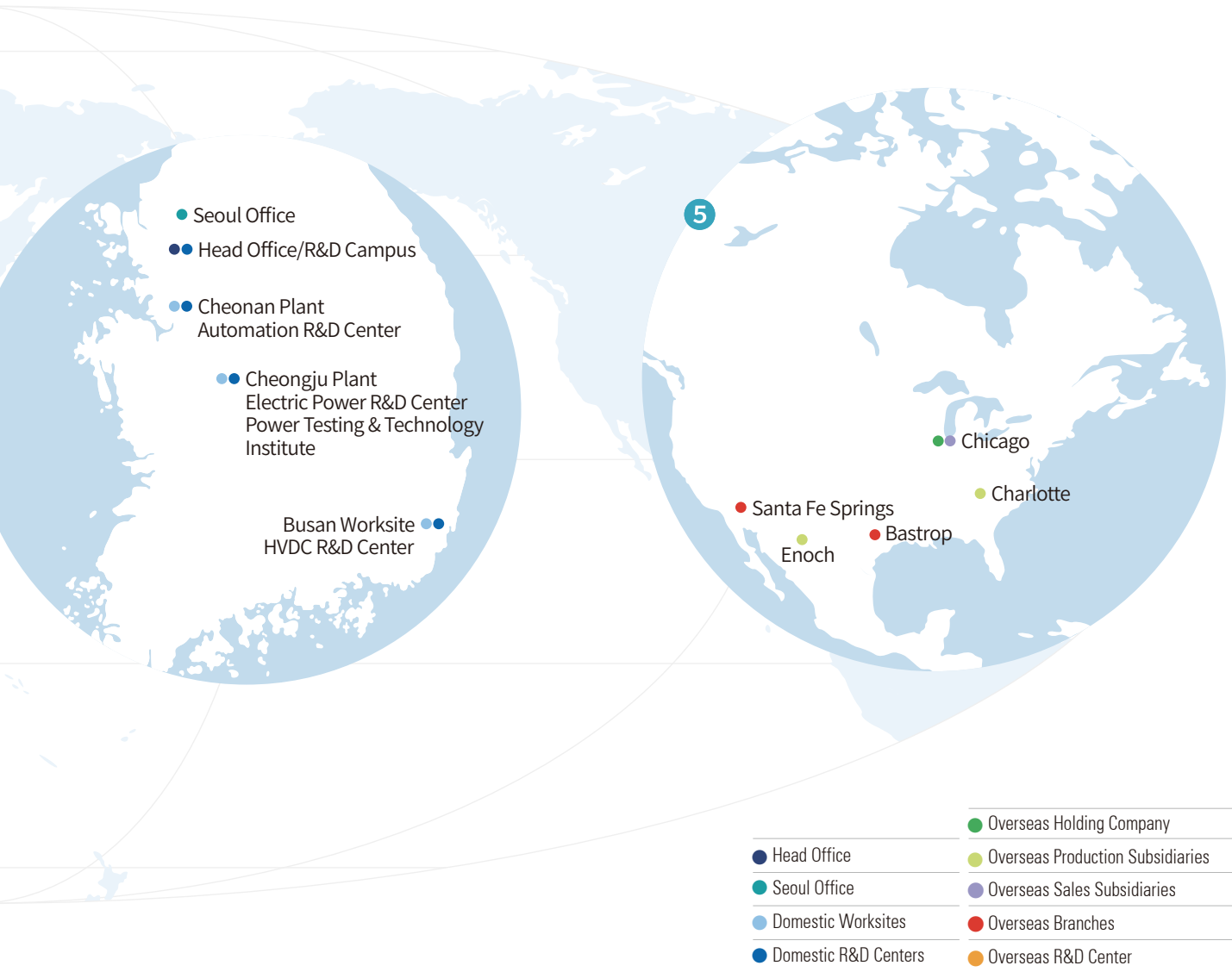

► **Factory**



**Power Device R&D Center**  
Leading technology in electric industry and continuously developing future-growth dynamic engines



**Cheongju Factory (Korea)**  
Electric Products, Mold TR, MV/LV Switchgear, and HV GIS



**Cheonan Factory (Korea)**  
PLC, AC Drive, HMI, DCS, and PV Module



**Busan Factory (Korea)**  
HV TR, HVDC, and FACTS



**Ulsan Factory (Korea, LS Power Solution)**  
HV TR, Mold TR, and Pad TR



**PT&T (Testing laboratory)**  
Internationally-renowned testing center that has formed partnerships with UL, CE, KEMA, and CESI



**Wuxi Factory (China)**  
Electric Products



**Dalian Factory (China)**  
MV/LV Switchgear, and MV Contactor



**Hanoi Factory (Vietnam)**  
MV/LV Switchgear, and Mold TR



**Tangerang Factory (Indonesia)**  
Pad TR, Distribution Oil TR, and Distribution Panel



## Headquarters

127 LS-ro (Hogye-dong) Dongan-gu, Anyang-si, Gyeonggi-Do, 14119, Korea

## Seoul Office

LS Yongsan Tower, 92, Hangang-daero, Yongsan-gu, Seoul, 04386, Korea  
TEL: 82-2-2034-4916, 4684, 4429

## China

LS ELECTRIC (Dalian) Co., Ltd.  
+86-411-8730-5872  
china.dalian@lselectric.com.cn

LS ELECTRIC (Wuxi) Co., Ltd.  
+86-510-6851-6666  
china.wuxi@lselectric.com.cn

LS ELECTRIC (Lishui) Co., Ltd.  
+86-578-6866-780  
china.lishui@lselectric.com.cn

Shanghai Office  
+86-21-5237-9977  
china@lselectric.com.cn

Beijing Office  
+86-10-5095-1631  
china@lselectric.com.cn

Guangzhou Office  
+86-20-3818-2883  
china@lselectric.com.cn

Qingdao Office  
+86-532-8501-2065  
china@lselectric.com.cn

Chengdu Office  
+86-28-8670-3201  
china@lselectric.com.cn

Nanjing Office  
+86-25-84 67-0005  
china@lselectric.com.cn

## India

India Office  
+91-80-6142-9108  
Info\_india@ls-electric.com

## Indonesia

PT. LS ELECTRIC INDONESIA  
+62-21-2933-7614  
indonesia@ls-electric.com

## Italy

Italy office  
+39-030-8081-833  
italia@ls-electric.com

## Japan

LS ELECTRIC Japan Co., Ltd.  
+81-3-6268-8241  
japan@ls-electric.com

Tokyo Office  
+81-3-6268-8241  
tokyo@ls-electric.com

## Netherlands

LS ELECTRIC Europe B.V.  
+31-20-654-1424  
europartner@ls-electric.com

## Russia

Moscow Office  
+7-499-682-6130  
info@lselectric-ru.com

## Singapore

Singapore Office  
+65-6958-8162  
singapore@ls-electric.com

## Spain

LS ELECTRIC IBERIA S.L.U.  
+34-910-28-02-74  
iberia@ls-electric.com

## Thailand

Bangkok Office  
+66-2-128-0295  
thailand@ls-electric.com

## Türkiye

LS ELECTRIC Türkiye Co., Ltd.  
+90-212-806-1252  
turkiye@ls-electric.com

## U.A.E.

LS ELECTRIC Middle East FZE (Dubai)  
+971-4-886-5360  
middleeast@ls-electric.com

## USA

LS ELECTRIC America Inc.  
+1-800-891-2941  
sales.us@lselectricamerica.com

LS ENERGY SOLUTIONS LLC  
+1-980-221-0654  
info@ls-es.com

MCM Engineering II  
+1-435-865-0125  
sales.us@lselectricamerica.com

America Western Office  
+1-949-333-3140  
america@ls-electric.com

America Bastrop Campus  
+1-800-891-2941 EXT 2  
power\_support.us@lselectricamerica.com

## Vietnam

LS ELECTRIC Vietnam Co., Ltd.  
+84-222-2221-110  
vietnam@ls-electric.com

Hanoi Office  
+84-24-6275-8054  
vietnam@ls-electric.com

Ho Chi Minh Office  
+84-3823-7890  
vietnam@ls-electric.com

Specifications in this catalog are subject to change without notice due to continuous product development and improvement

© 2017. 04 LS ELECTRIC Co., Ltd. All rights reserved. English (03) 2026. 04 HumanPower

[www.ls-electric.com](http://www.ls-electric.com)