



**Beyond** X™

# Susol MCCB

Up to 690/800/1000Vac  
for Renewable Application and High Altitude



**LS** ELECTRIC

# Characteristics and Rating

## Characteristics

For renewable and high altitude applications

- High breaking capacity (up to 1000V AC)
- Compact size
- Various trip units
- Standards: IEC/UL rated



## Rating

FRAME		UTV250		
Rated voltage		690 <sup>1)</sup> /800/1000 Vac		
Rated current		60, 80, 100, 150, 200, 250A		
Number of poles		3/4		
Breaker type		E	N	H <sup>2)</sup>
<b>UL489</b>				
Interrupting capacity (kA) UL, CSA	AC 800V	25	42	50
	AC 1000V	14	20	30
<b>IEC 60947-2</b>				
Maximum fault current (kA), Icu	AC 690V	65	85	100
	AC 800V	25	40	50
	AC 1000V	15	20	30
Fault breaking capacity (kA), Ics	AC 690V	65	85	100
	AC 800V	18.5	30	37.5
	AC 1000V	8	10	15
Insulation voltage, Ui		1000 Vac		
Impulse withstand voltage, Uimp		8 kV		
Utilization category		A		
<b>IEC 60947-3</b>				
Insulation voltage, Ui		1000 Vac		
Impulse withstand voltage, Uimp		8 kV		
Rated short-time withstand current, Icw		3 kA		
Utilization category		AC-23A		
<b>Trip Unit</b>				
Trip unit	FTU*	60, 80, 100, 150, 200, 250A		
	FMU*	60, 80, 100, 150, 200, 250A		
	ATU*	100, 150, 200, 250A		
	MCS**	60, 80, 100, 150, 200, 250A		
	DSU***	250A		
<b>Accessories</b>				
Unit mounted		available		
Mechanical lugs		available		
Busbar connectors		available		
Control wire terminal kit		available		
Motor operator		available		
Interphase barriers		available		
Shunt trip		available		
Undervoltage trip		available		
Auxiliary switch		available		
Alarm switch		available		
Directly-Mounted rotary operating handle		available		
IEC-Door-Mounted operating mechanisms		available		
Padlock attachment		available		
Weight(approximate), lbs.(kg)	3 Pole	4.85(2.20)		
	4 Pole	6.35(2.88)		
Dimensions, Inches(mm)		<b>W</b>	<b>H</b>	<b>D</b>
	3 Pole	4.13(105)	8.07(205)	3.62(92)
	4 Pole	5.51(140)	8.07(205)	3.62(92)

1), 2) TBD

\* FTU, FMU, ATU: UL489, IEC 60947-2

\*\* UL 489 Only

\*\*\* IEC 60947-3 Only

## Characteristics

For renewable and high altitude applications

- High breaking capacity (up to 1000V AC)
- Various trip units
- Standards: IEC rated



## Rating

FRAME		UTV400		
Rated voltage		800/1000 Vac		
Rated current		320, 400A		
Number of poles		3/4		
Breaker type		E	N	H
IEC 60947-2				
Interrupting capacity (kA) AC 800V, Icu		25	42	50
Interrupting capacity (kA) AC 1000V, Icu		15	20	30
Fault breaking capacity (kA), AC Ics	AC 800V	25	25	25
	AC 1000V	13	13	13
Insulation voltage, Ui		1000 Vac		
Impulse withstand voltage, Uimp		8 kV		
Utilization category		A		
Trip Unit				
Trip unit	FTU*	320, 400A		
	FMU*	320, 400A		
	ATU*	320, 400A		
Accessories				
Unit mounted		available		
Mechanical lugs		available		
Busbar connectors		available		
Control wire terminal kit		available		
Motor operator		available		
Terminal shields		available		
Interphase barriers		available		
Shunt trip, SHT		available		
Undervoltage trip, UVT		available		
Auxiliary switch, AX		available		
Alarm switch, AL		available		
Directly-Mounted rotary operating handle		available		
IEC-Door-Mounted operating mechanisms		available		
Padlock attachment		available		
Weight(approximate), lbs.(kg)	3 Pole	15.87(7.2)		
	4 Pole	19.18(8.7)		
Dimensions, Inches(mm)		<b>W</b>	<b>H</b>	<b>D</b>
	3 Pole	5.51(140)	11.42(290)	4.33(110)
	4 Pole	7.34(186.5)	11.42(290)	4.33(110)

\* FTU, FMU, ATU: IEC 60947-2    \*\* IEC 60947-3 Only

# Ordering & Temperature derating

## Ordering

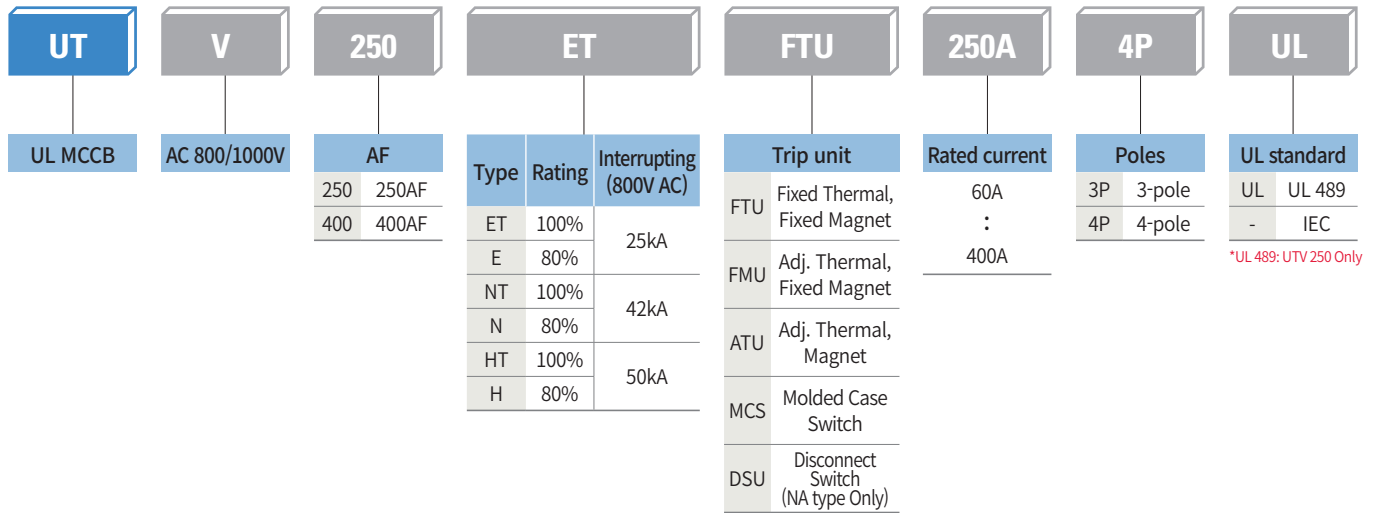

## Temperature derating

Type	Rated current (A)	Derating current (A)	Derating (%)	Compensated rated current in accordance with ambient temperature (A)																		
				10°C		20°C		30°C		40°C		45°C		50°C		60°C		70°C				
UL489	UTV250	60	60	100%	60	100%	60	100%	60	100%	60	100%	60	100%	59	98%	57	95%	53	89%	50	83%
		80	80	100%	80	100%	80	100%	80	100%	80	100%	80	100%	78	98%	76	95%	71	89%	66	83%
		100	100	100%	100	100%	100	100%	100	100%	100	100%	100	100%	98	98%	95	95%	89	89%	83	83%
		150	150	100%	150	100%	150	100%	150	100%	150	100%	150	100%	146	97%	141	94%	132	88%	123	82%
		200	200	100%	200	100%	200	100%	200	100%	200	100%	200	100%	196	98%	190	95%	178	89%	166	83%
IEC 60947-2	UTV400	250	250	100%	250	100%	250	100%	250	100%	250	100%	250	100%	243	97%	235	94%	220	88%	205	82%
		320	320	100%	320	100%	320	100%	320	100%	320	100%	320	100%	310	98%	301	95%	282	89%	262	83%
		400	400	100%	400	100%	400	100%	400	100%	400	100%	400	100%	388	97%	376	94%	352	88%	328	82%

# Characteristic curve

MCCB up to 690/800/1000Vac

## UTV250 MCCB

FTU  
FMU  
60~80A

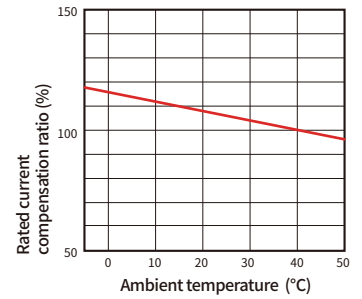
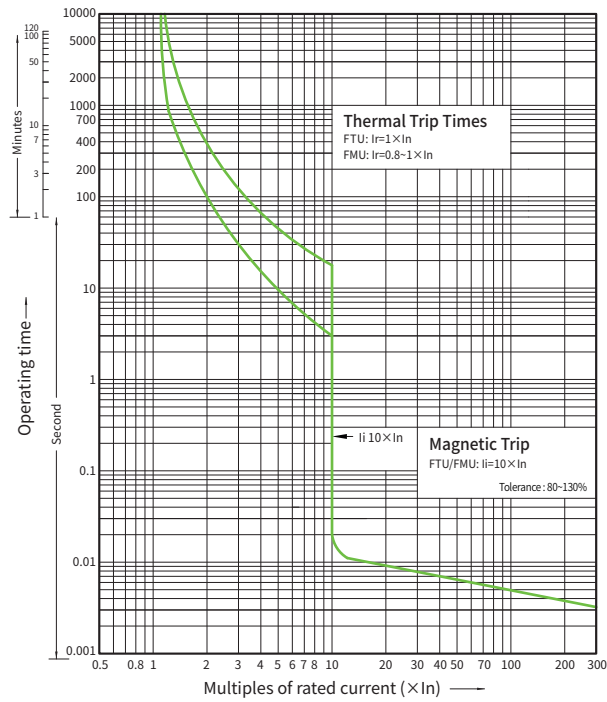

## UTV250 MCCB

FTU  
FMU  
ATU  
100~250A

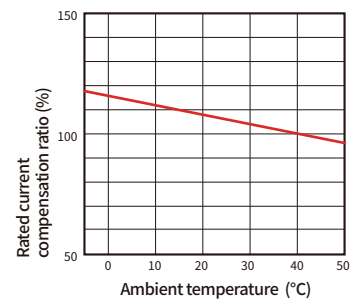
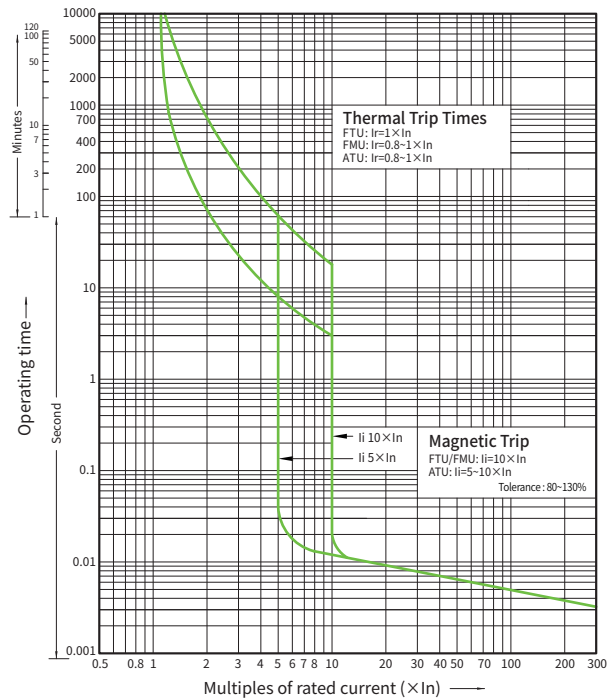

# Characteristic curve

## UTV250 MCS

60 ~ 250A

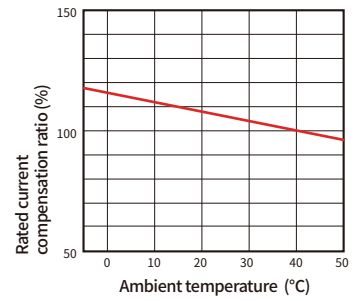
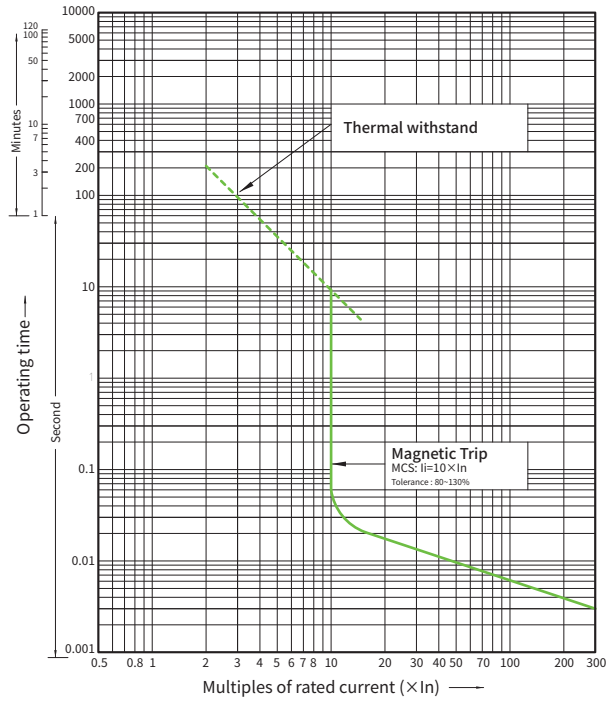

### UTV400 MCCB

ATU  
300~400A

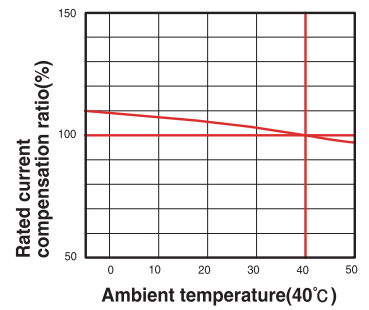
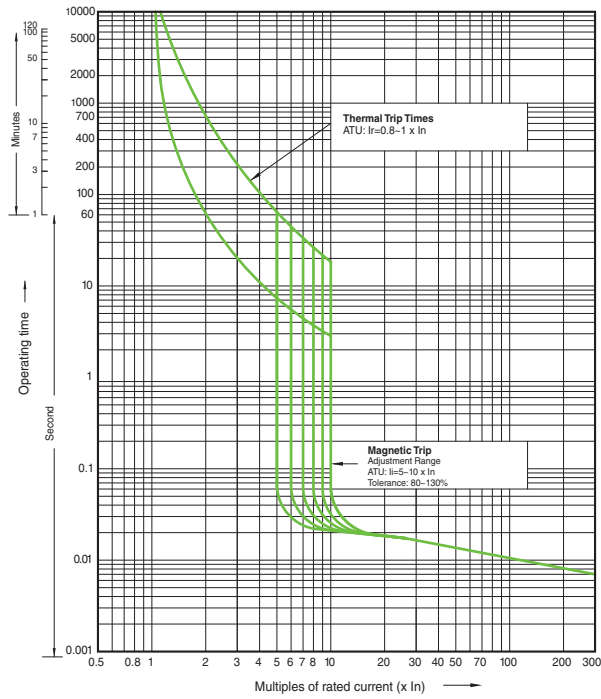

Rating UTS400	ATU		
	2P/3P	Rating Range (0.8~1 x In)	MAG Trip (80%~120%) (5~10 x In)
320	○	256~320A	1600~3200A
400	○	320~400A	2000~4000A

# Dimensions

UTV250

[Unit:inch(mm)]

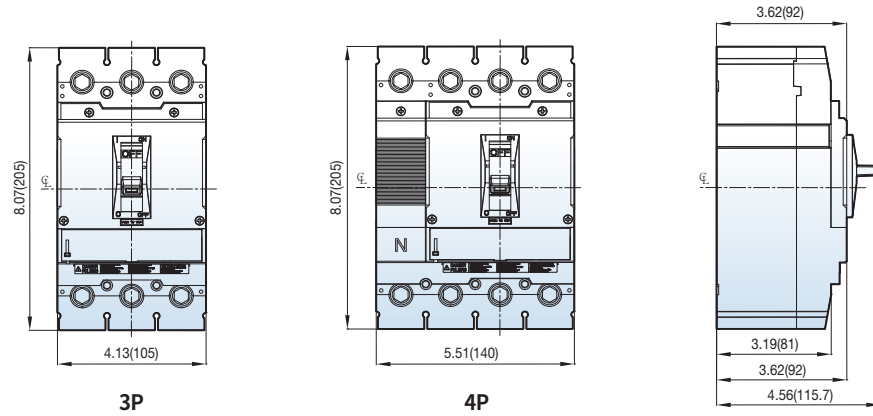

### < Panel drilling >

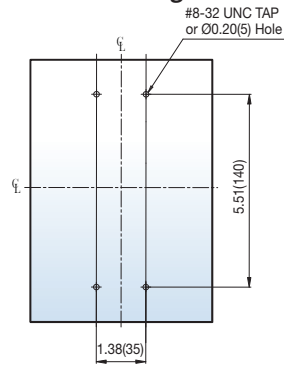

### < Front panel cutting >

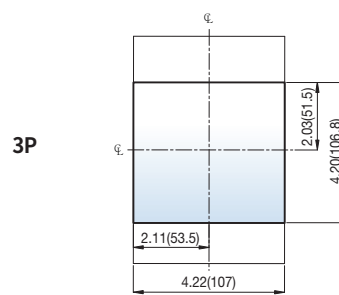

### Terminal section

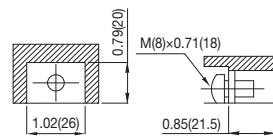

### Conductor

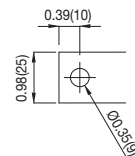

### < Panel drilling >

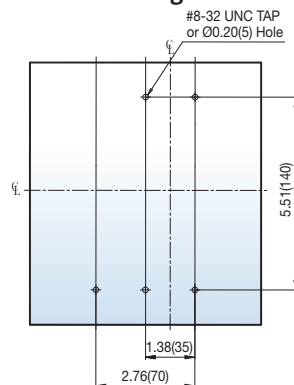

### < Front panel cutting >

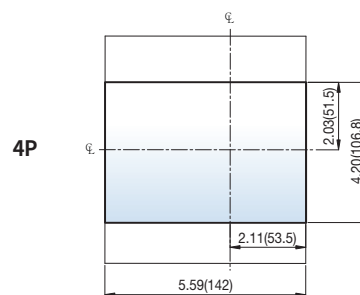

UTV250

[Unit:inch(mm)]

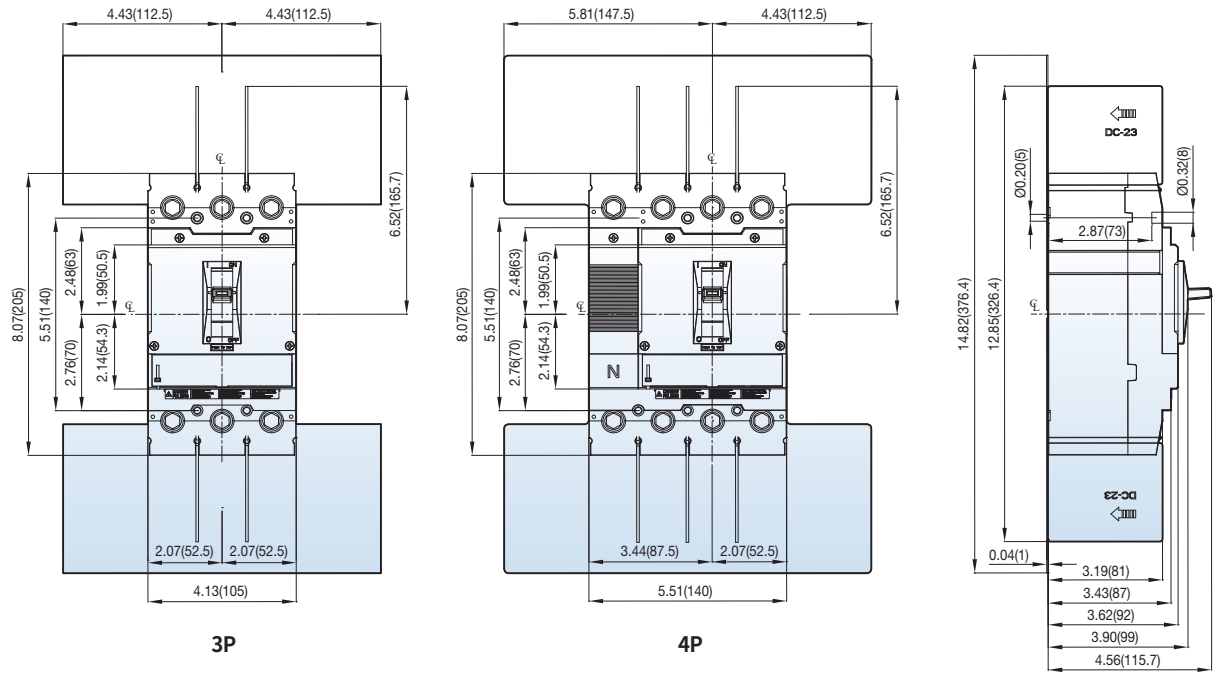

< By insulation and separation distance >

- One side (30mm or more),
- Top and bottom (106mm or more)
- Between products (60mm or more)

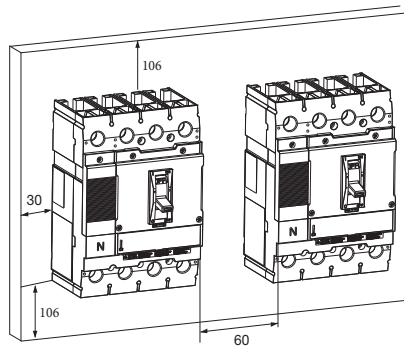

# Dimensions

UTV400

[Unit:inch(mm)]

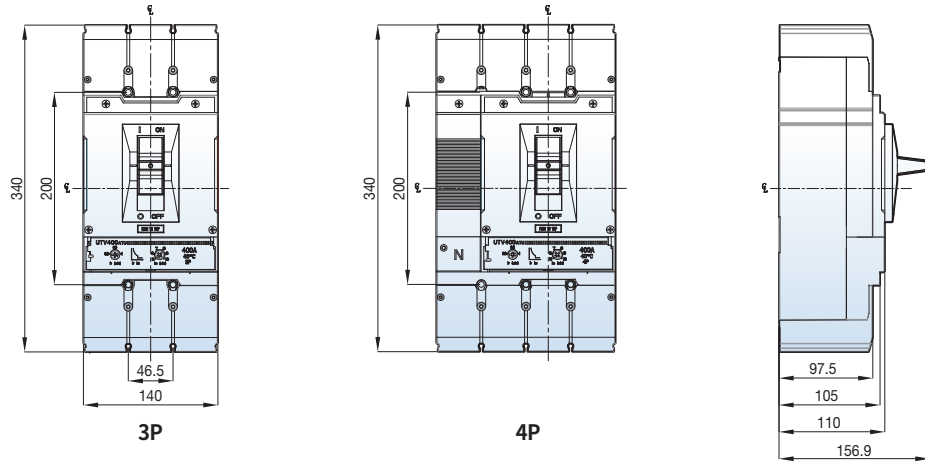

### < Panel drilling >

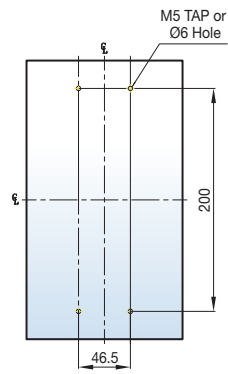

### < Front panel cutting >

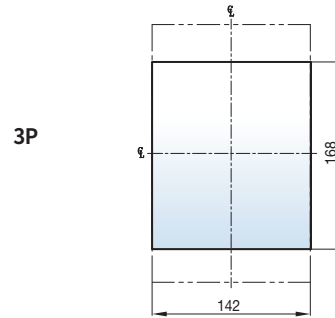

### Terminal section

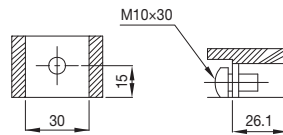

### Conductor

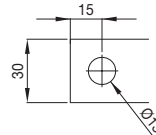

### < Panel drilling >

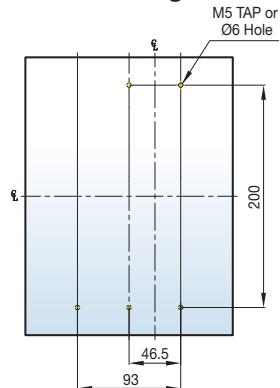

### < Front panel cutting >

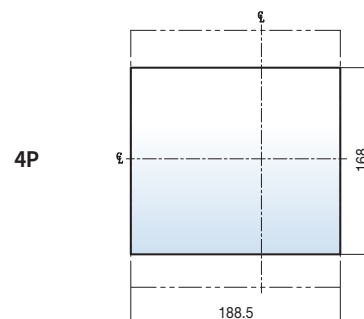

UTV400

[Unit:inch(mm)]

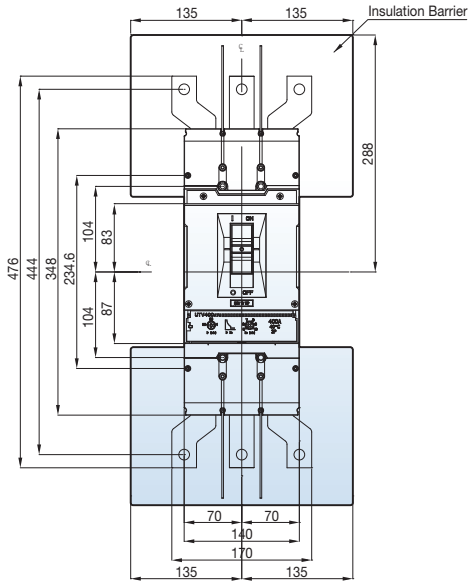

3P

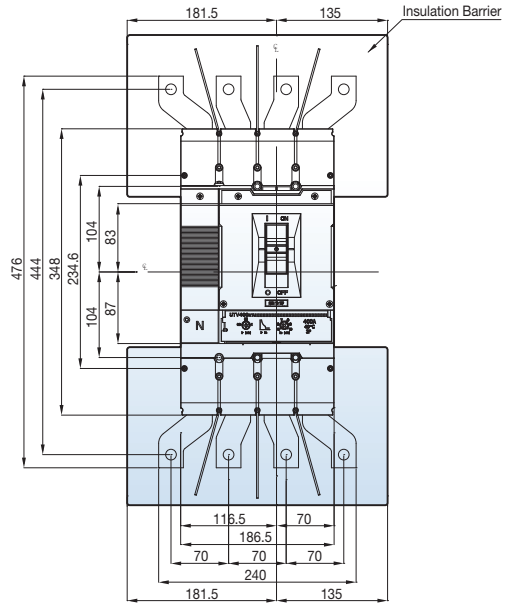

4P

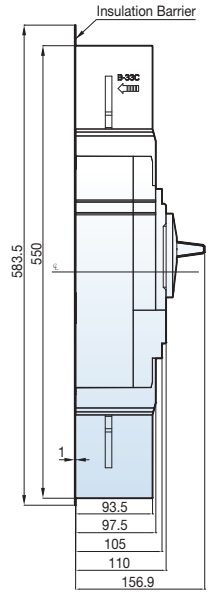

- 93.5
- 97.5
- 105
- 110
- 156.9



### LS ELECTRIC America Inc. Chicago Head Office

625 Heathrow Dr, Lincolnshire, IL 60069, USA  
Tel: 1-224-352-2265 E-Mail: sales.us@lselectricamerica.com

### Headquarter

127 LS-ro (Hogye-dong) Dongan-gu, Anyang-si, Gyeonggi-Do, 14119, Korea

### Seoul Office

LS Yongsan Tower, 92, Hangang-daero, Yongsan-gu, Seoul, 04386, Korea  
TEL: 82-2-2034-4916, 4684, 4429

### China

LS ELECTRIC (Dalian) Co., Ltd.  
+86-411-8730-7560  
china.dalian@lselectric.com.cn

LS ELECTRIC (Wuxi) Co., Ltd.  
+86-510-8534-6666  
china.wuxi@lselectric.com.cn

LS ELECTRIC (Lishui) Co., Ltd.  
+86-133-6207-7980  
china.lishui@lselectric.com.cn

Shanghai Office  
+86-21-5237-9977  
china@lselectric.com.cn

Beijing Office  
+86-10-5095-1631  
china@lselectric.com.cn

Guangzhou Office  
+86-20-3818-2883  
china@lselectric.com.cn

Qingdao Office  
+86-532-8501-2065  
china@lselectric.com.cn

Chengdu Office  
+86-28-8670-3201  
china@lselectric.com.cn

Nanjing Office  
+86-25-8467-0005  
china@lselectric.com.cn

### India

India Office  
+91-80-6142-9108  
Info\_india@ls-electric.com

### Indonesia

PT. LS ELECTRIC INDONESIA  
+62-21-2933-7614  
indonesia@ls-electric.com  
PT SYMPHOS ELECTRIC  
+62-81-1900-1474  
marketing@symphos-weltraf.com

### Italy

Italy office  
+39-030-8081-833  
italia@ls-electric.com

### Japan

LS ELECTRIC Japan Co., Ltd.  
+81-3-6268-8241  
japan@ls-electric.com  
Tokyo Office  
+81-3-6268-8241  
tokyo@ls-electric.com

### Netherlands

LS ELECTRIC Europe B.V.  
+31-20-654-1424  
europartner@ls-electric.com

### Russia

Moscow Office  
+7-499-682-6130  
info@lselectric-ru.com

### Singapore

Singapore Office  
+65-6958-8162  
singapore@ls-electric.com

### Spain

LS ELECTRIC IBERIA S.L.U.  
+34-910-28-02-74  
iberia@ls-electric.com

### Thailand

Bangkok Office  
+66-2-128-0295  
thailand@ls-electric.com

### Türkiye

LS ELECTRIC Türkiye Co., Ltd.  
+90-212-806-1252  
turkiye@ls-electric.com

### U.A.E

LS ELECTRIC Middle East FZE (Dubai)  
+971-4-886-5360  
middleeast@ls-electric.com

### USA

LS ELECTRIC America Inc.  
+1-800-891-2941  
sales.us@lselectricamerica.com

LS ENERGY SOLUTIONS LLC  
+1-980-221-0654  
cmfeldman@ls-es.com

MCM Engineering II  
+1-435-865-0125  
sales.us@lselectricamerica.com

America Western Office  
+1-949-333-3140  
america@ls-electric.com

America Bastrop Campus  
+1-224-352-2265  
sales.us@lselectricamerica.com

### Vietnam

LS ELECTRIC Vietnam Co., Ltd.  
+84-222-2221-110  
vietnam@ls-electric.com

Hanoi Sales Office  
+84-24-6275-8054  
vietnam@ls-electric.com

Ho Chi Minh Sales Office  
+84-3823-7890  
vietnam@ls-electric.com

## DIGITAL SUPPORT HUB



### LSE LENS

Scan the QR code to instantly access product materials



### Product Finder

Quickly discover the best-fit product for your needs



### Download Center

Instantly access datasheets, manuals, and CAD files



### Tech Hub-Youtube

Watch trusted tutorials and product guides from real experts

Specifications in this catalog are subject to change without notice due to continuous product development and improvement

© 2022. 07 LS ELECTRIC Co., Ltd. All rights reserved. / English (05) 2026. 02 Staffcom

[www.LSElectricAmerica.com](http://www.LSElectricAmerica.com)