

Beyond X™

UL LV Panelboard
Installation Operation Maintenance Manual



LS ELECTRIC

Table of contents

1. INTRODUCTION

- 1.1 Inspection and packaging 4
- 1.2 Document replacement 4
- 1.3 Intended use 4
- 1.4 References 5

2. SAFETY PRECAUTIONS

- 2.1 Handling electrical machinery and apparatus 8
- 2.2 Electrical shock prevention 12

3. GENERAL

- 3.1 Successful operation of panelboards 16
- 3.2 Qualified personnel 16
- 3.3 Definition of qualified personnel 16
- 3.4 Suitable ratings 17

4. INSTALLATION OF PANELBOARD CABINETS (BOXES)

- 4.1 Installation instructions 18
- 4.2 Location in building 18
- 4.3 Flammable material 18
- 4.4 Unusual service conditions 18
- 4.5 Indoor damp locations 18
- 4.6 Wet locations 18
- 4.7 Clearance from ceiling 18
- 4.8 Space around the cabinet 19
- 4.9 Mounting of cabinet 19
- 4.10 Flush mounting in wall 19
- 4.11 Unused openings in cabinet 19
- 4.12 Grounding of panelboard cabinets 19

5. INSTALLATION OF CONDUIT AND CONDUCTORS

- 5.1 Conduits installation 20
- 5.2 Machining conduit holes 20
- 5.3 National electrical code, article 300 22
- 5.4 Conductor length 22
- 5.5 Exercise care 22
- 5.6 National electrical code, section 725.54 22

6. INSTALLATION OF PANELBOARD

- 6.1 Proper storage 23
- 6.2 Unpacking 23
- 6.3 Inspection 23
- 6.4 Care 23
- 6.5 Manufacturer's instructions 24
- 6.6 Line and branch conductors 24

6.7 Panelboard grounding	24
6.8 Proper type or class and rating	25
6.9 Debris	25
6.10 Steps in section 7	25
7. STEPS TO TAKE BEFORE ENERGIZING	
7.1 Accessible electrical connections	26
7.2 Blocks and packing materials	28
7.3 Switches, circuit breakers, and other operating mechanisms	28
7.4 Short circuits and ground faults	28
7.5 Ground fault protection system	28
7.6 Adjustable time current trip device settings	28
7.7 Grounding connections	28
7.8 Foreign material	29
8. INSTALLATION OF CABINET FRONT	
8.1 Cabinet front or trim package	30
8.2 Unpacking	30
8.3 Covers and doors	30
8.4 Touch-up	30
8.5 Front alignment	30
9. ENERGIZING EQUIPMENT	
9.1 Qualified personnel	31
9.2 Load on the panelboard	31
9.3 Energized in sequence	31
9.4 Loads such as lighting circuits, contactors, heaters, and motors	31
10. MAINTENANCE	
10.1 Maintenance program	32
10.2 Panelboard which has been carrying its regular load for at least 3 hours	32
10.3 Inspect panelboard once each year	32
10.4 Accumulation of dust and dirt	32
10.5 Proper ampere, voltage, and interrupting ratings	33
10.6 Operation of all mechanical components	34
10.7 Damaged insulating material and assemblies	35
10.8 Moisture, signs of previous wetness or dripping	35
10.9 Before cleanup and corrective action is attempted	36
10.10 Severe electrical short circuit	36
10.11 Ground fault protection system	36
10.12 Insulation resistance	36
11. PERMISSIBLE LOADING OF PANELBOARDS	
11.1 National electrical code	37
11.2 Harmonics in electrical system	37

INTRODUCTION

1. Introduction

This manual provides instructions for the general installation, operation, and maintenance of LV Panelboard equipment manufactured by LS ELECTRIC. Engineering, installation, and operating staff supervisors should familiarize themselves with this manual and become acquainted with the appearance and characteristics of each piece of equipment mounted in or contained within the panelboard. These instructions and procedures apply to LV panelboard installations by LS ELECTRIC. This manual has been written in compliance with NEMA PB 1.1-2007.

1.1 Inspection and packaging

The LV panelboard is carefully inspected and packaged at the assembly factory. Quality control personnel verify compliance with structural and electrical standards, codes, and specifications. After these pre-shipment inspections are completed, the panelboard is divided to fit the packaging unit and securely packaged to prevent damage during transport. The factory order number, identification number, and shipping weights are clearly marked on each shipping section.

1.2 Document replacement

Contact your local LS ELECTRIC representative to obtain replacement instruction sheets in case of loss or damage.

1.3 Intended use

LV panelboard units are exclusively intended for switching and distributing electrical energy. They must be used within the scope of the specified standards and panelboard-specific technical data. Any other use constitutes improper use and may result in hazards or damage.

Liability Disclaimers

The manufacturer shall not be held responsible for any damage if:

- Instructions in this manual are not followed.
- The panelboard is not operated according to its intended use (see above).
- The panelboard is assembled, connected, or operated improperly.
- Accessories or spare parts used were not approved by the manufacturer.
- The panelboard is modified without the manufacturer's approval, or if inadmissible parts are added. No liability is accepted for parts provided by customers, e. g., power cables.

1. Introduction

1.4 References

National Fire Protection Association (NFPA)

Batterymarch Park
Quincy, MA 02269

NFPA 70 2005 National Electrical Code
NFPA 70E 2004 Safety Related Work Practices

National Electrical Manufacturers Association (NEMA)

1300 North 17th Street, Suite 1752
Rosslyn, Virginia 22209

PB 1.1- 2007 General Instructions for Proper Installation, Operation, and Maintenance of Panelboards Rated
600 Volts or Less
AB 4- 2003 Guidelines for Inspection and Preventative Maintenance of Molded Case Circuit Breakers Used
in Commercial and Industrial Applications
PB 2.2- 2004 Application Guide for Ground Fault Protective Devices for Equipment Guidelines for Handling
Water Damaged Electrical Products

SAFETY PRECAUTIONS

2. Safety Precautions



WARNINGS

The low-voltage panelboard is safe and effective when proper precautions are taken.

When hazardous voltage and energy levels are present, failure to follow precautions may result in death or injury.

1. Never work around a live or energized bus. Do not remove bolted covers, bolted doors, or bolted access plates while the equipment is energized. The live bus is enclosed behind metal panels, which shall not be removed unless the bus is de-energized.
2. Never use a circuit breaker rated above the equipment's maximum voltage. Never use a breaker with a lower interrupting rating than the system is designed for.
3. Only qualified personnel should maintain or operate the panelboard. Maintenance personnel must be qualified to work with low-voltage equipment and familiar with panelboard components and their proper use. Operators should be trained in the correct operation of the panelboard and its components. Both personnel should have electrical shock and burn safety training.
4. Do not insert partially disassembled breakers, test breakers, ground-and-test devices, or other items into an energized cell. Tests using these devices shall only be conducted when the main bus is de-energized.
5. Never disconnect or open the secondary circuit of current transformers while they are connected to energized circuits. Voltages will develop between contacts. Keep spare current transformers shorted on their secondary circuits.
6. When circuits are opened for maintenance, repair, or inspection, lock circuit breakers or disconnect switches in the open position and tag or mark them to indicate they are locked open for safety purposes.

2. Safety Precautions

Before operating or working on any electrical equipment, read this manual carefully to understand functions and safety precautions.

In this manual, safety precautions are divided into two types:

[DANGER] and **[CAUTION]**

DANGER

A danger notice with this symbol indicates that failure to follow the recommended procedure or practice could result in serious injury.

CAUTION

A caution notice with this symbol indicates that failure to follow the recommended procedure or practice could result in minor or moderate personal injury and/or property damage.

Note that ignoring caution notices may lead to serious injury or damage in certain situations.

The safety notice contains important information and must be read before beginning any work with the relevant products.

SAFETY PRECAUTIONS

2. Safety Precautions

2.1 Handling electrical machinery and apparatus

To prevent accidents, anyone handling electrical machinery or apparatus must be thoroughly familiar with the precautions noted below and in Section 2, "Electric Shock Prevention."

Most accidents can be avoided by exercising caution. Always follow these precautions.

2.1.1 General Precautions

Observe the following precautions when performing maintenance or inspection to prevent electric shock or short circuits. (Accidents may occur if metal tools, flashlights, or other conductive materials are dropped.)



Working Preparations

Treat electrical equipment as highly flammable material at all times.

- Do not smoke or use open flames in the vicinity of the equipment.
- Wear a helmet, safety shoes, and appropriate work clothing when working on the equipment.
- Cut off the power supply; otherwise, there is a risk of electric shock from live busbars or other current-carrying parts when the panelboard or other electrical panels are opened.
- Ensure there is no voltage in the circuit before performing any electrical work, and ground the panel. Use a voltmeter, circuit tester, or similar device to verify de-energized conditions.
- Never work in the charging area, except in emergencies.
- Inspect the surroundings for potential hazards and inform your colleagues of your planned work.
- Provide sufficient lighting in the work area.
- Maintain an orderly work area; do not scatter tools.
- Learn the proper use of a circuit tester and other necessary tools.
- Read and understand Section, "Electric Shock Prevention."

2. Safety Precautions

2.1 Handling electrical machinery and apparatus

CAUTION

Inspection and Maintenance

- Daily Inspection
 - Check the panelboard for any visible damage. Pay special attention to unusual noise, odors, or discoloration.
- Periodic Inspection
 - Inspect each busbar connection, device mounting section, and wiring section for loose connections or components. If any looseness is found, retighten the bolts.
 - Check the appearance of each device (air circuit breaker, protective relay, current and voltage transformers, fuses, module cards, etc.) for missing parts or damage. Replace any defective components with spare parts.
 - Inspect each device (MCCB, MCB, protective relay, current and voltage transformers, fuses, etc.) for unusual noise, odors, or discoloration. Replace any components showing these issues.
 - Check the mechanical operation of each device (MCCB, MCB, protective relay, etc.) for malfunctions. Replace any malfunctioning components with spare parts.

SAFETY PRECAUTIONS

2.1 Handling electrical machinery and apparatus

2. Safety Precautions

2.1.2 Precautions for Hot-line Work

Never perform hot-line work unless absolutely necessary. If repair of live circuits or electrical devices is unavoidable, refer to Section 2, "Electric Shock Prevention," and follow the precautions listed below.



Hot-line Work

Always treat electrical equipment as highly flammable material.

- Perform electrical work only under the presence and/or supervision of competent personnel, observing the following preparatory steps:
 - Provide sufficient lighting for the work area.
 - Remove wristwatches, rings, and other metal articles from the body.
 - Wear long-sleeve work clothes that fit close to the body, and ensure clothing and shoes are dry.
 - Insulate yourself from the equipment and place insulating material over any devices or structural components that may be accidentally touched.
 - Cover tools with vinyl tape wherever possible.
 - When performing electrical work, cover live parts with insulating material or safety shutters to protect against dropped tools, scrap wire, or inadvertent contact with live parts.
 - Place insulation between the live section of the circuit and the section to be worked on.
 - Wear rubber gloves on both hands and rubber boots.
- Work primarily with your dominant hand whenever possible, and maintain your balance. A loss of balance, for example due to movement of the ship, may cause an accident.
- In emergency situations, the site manager should cut off power immediately and report the issue to the relevant personnel.

2.1 Handling electrical machinery and apparatus

2. Safety Precautions

2.1.3 Guidelines for Fire Extinguishing

In the event of an electrical fire, promptly follow the procedures below.

DANGER

Fire Extinguishing

- Cut off the power to the circuit or device that started the fire.
- Cut off the power to other circuits or devices that may be affected by the fire, including those at risk if the fire spreads.
- Do not cut off power to any devices whose shutdown could cause a serious accident.
- Inform your supervisor or nearby personnel of the fire.
- Use a fire extinguisher (powder or halide type) to put out the fire.
In small rooms or enclosed sections, there is a risk of asphyxiation from fire-extinguishing materials. Take precautions to avoid this.
In all cases of electrical fires, always cut off the power supply first.
- Be cautious when using water to extinguish an electrical fire.
The person extinguishing the fire may be electrocuted if current flows through the water.
- Consider carefully when choosing between seawater and a fire extinguisher.
Once electrical devices come into contact with seawater, it is difficult to restore them to their original condition.
In some cases, a fire extinguisher may be the best choice, even if it takes more time than seawater to extinguish the fire.

2.1.4 Maintenance and Inspection of Breaker

CAUTION

Maintenance of Breaker

Refer to the operating instructions of the specific breaker for correct maintenance, inspection, and replacement procedures.

SAFETY PRECAUTIONS

2. Safety Precautions

2.1 Handling electrical machinery and apparatus

2.1.5 Precautions for Breaker Operation

 **DANGER**

Breaker Operation

- Before operating circuit breaker switches, confirm the following to avoid endangering others:
 - Ensure that powering any or all devices in the circuit will not cause problems.
 - Verify that no other individuals are working on the same circuit.
If others are working on the same circuit, inform them of the breaker or switch you will operate and advise caution.
 - Confirm that all protective devices (protective relays, fuses, etc.) in the circuits are in proper working order.
- Operate breakers and switches as follows:
 - Perform all operations with your dominant hand. Keep the other hand back and away from the breaker or switch, except for operations requiring both hands.
 - Operate knife switches with one quick motion.

2.1.6 Precautions for Current and Voltage transformer Operation

 **DANGER**

CT and VT Operation

Do not open the secondary side of a current transformer.

If the secondary side must be opened for repair, do not leave it open. High voltage may be generated on the secondary side when current flows through the primary side. Periodically check the secondary-side connections to ensure they are tight.

2. Safety Precautions

2.1 Handling electrical machinery and apparatus

2.1.7 Precautions for Changing Fuses

DANGER

Changing Fuses

- Changing fuses:
 - When removing a fuse, carefully unscrew the fuse cap.
 - When inserting the fuse into the fuse clip, ensure that the conductive part does not touch the gap between fuse clips. Contact may cause a short-circuit accident.
 - When changing a fuse, avoid contact with energized devices or any other live parts nearby (e.g., busbars). Contact may result in electric shock.
- Selecting the right spare:
 - Use a spare fuse of the same type and rated current as the blown fuse.

2.1.8 Other Precautions

CAUTION

Other Precautions

- Keep front doors and rear covers or doors closed, except when it is necessary to open them.
- Before starting electrical work, secure all moving parts by fastening the door or any objects that can move the panelboard cover.
- Do not remove protective plates or covers. If removal is necessary, ensure they are returned to their proper positions.
- Do not leave tools or work materials on or around the panelboard after completing work.

SAFETY PRECAUTIONS

2. Safety Precautions

2.2 Electrical shock prevention

2.2.1 General Information on Electric Shock

- The Danger of Electricity

- Receiving an electric shock is extremely dangerous.

- Even a relatively small amount of current can be fatal if it passes through the head, lungs, or other vital organs.

- 220 V AC is more dangerous than we think.

- At 220 V AC, 60/50 Hz, even 50 milliamperes (mA) is dangerous and 50 – 100 mA can cause a fatal electric shock.

- Symptoms of Electric Shock

The symptoms described below require immediate treatment with artificial respiration or Cardiopulmonary Resuscitation (CPR) until the victim recovers. These symptoms indicate electric shock and should not be mistaken for death. It is common for a person exhibiting these symptoms to recover even after several hours of artificial respiration or CPR. The symptoms are listed in order from mild to most severe:

The symptoms are listed in order from mild to most serious cases.

- Breathing stops.

- Normal breathing can usually be restored after a short period of artificial respiration.

- Breathing stops, the face is pale, and the pulse is very weak or undetectable.

- Totally unconscious.

- In the worst case, the victim's body may become rigid within two to three minutes after the shock.

2. Safety Precautions

2.2 Electrical shock prevention

2.2.2 Prevention of Electric Shock

Anyone who operates, maintains, or repairs electrical equipment, or who supervises such work, shall take the following measures to prevent electric shock.



Prevention of Electric Shock

- Never estimate the voltage applied to a circuit until it has been confirmed by measurement.
- Always disconnect the power supply and verify that no voltage is present before performing any electrical work. Most accidents occur because the power is mistakenly assumed to be off.
- Always use rubber gloves, rubber boots, and an insulating mat when performing electrical work.
- Tag the power supply switch when performing electrical work.
(ex. "Do Not Turn on Power: Maintenance Work")
- Turning on the power during maintenance may cause a serious accident.
- Operate switches with your dominant hand while keeping the other hand away from your body.
- The site manager shall remain near the panelboard installation area to immediately disconnect the power in case of an accident.

3. General



WARNING

Hazardous voltages in electrical equipment can cause severe personal injury or death. Unless otherwise specified, inspection and maintenance shall be performed only on panelboards and equipment from which power has been turned off, disconnected, and electrically isolated to prevent accidental contact with energized parts. Follow all manufacturer's warnings and instructions.

※ Safety

Related work practices, as described in NFPA 70E, shall be followed at all times.



CAUTION

Hydrocarbon spray propellants and hydrocarbon-based sprays or compounds can degrade certain plastics. Contact the panelboard manufacturer before using these products to clean, dry, or lubricate components during installation or maintenance.

3.1 Successful operation of panelboards

The safe and reliable operation of panelboards depends on proper installation, operation, and maintenance. Failure to comply with fundamental installation and maintenance requirements may result in personal injury, death, or damage to electrical equipment or other property.

3.2 Qualified personnel

Installation, operation, and maintenance of panelboards shall be performed only by qualified personnel.

3.3 Definition of qualified personnel

For the purposes of these guidelines, a qualified person is one who is familiar with the installation, construction, and operation of the equipment and the associated hazards. In addition, the person shall:

3.3.1 Requirements

Be knowledgeable of the requirements of the National Electrical Code and of all other applicable codes, laws, and standards.

3. General

3.3 Definition of qualified personnel

3.3.2 Established Safety Practices

Shall be trained and authorized to test, energize, clear, ground, tag, and lock out circuits and equipment in accordance with established safety practices.

3.3.3 Protective Equipment

Shall be trained in the proper care and use of protective equipment, such as rubber gloves, hard hats, safety glasses or face shields, and flame-resistant clothing, in accordance with established safety practices.

3.3.4 First Aid

Shall be trained in rendering first aid.

3.4 Suitable ratings

Shall verify that all equipment being installed has ratings suitable for the installation.

INSTALLATION OF PANELBOARD CABINETS (BOXES)

4. Installation of panelboard cabinets (boxes)

4.1 Installation instructions

Install the cabinet in a neat and professional manner. Follow all of the manufacturer's installation instructions.

4.2 Location in building

Select an installation location that is readily accessible and protected from physical damage.

4.3 Flammable material

Select an installation location that is away from flammable materials.

4.4 Unusual service conditions

Do not install the cabinet where it will be exposed to ambient temperatures above 40 °C (104 °F), corrosive or explosive fumes, dust, vapors, dripping or standing water, abnormal vibration, mechanical shock, high humidity, tilting, or unusual operating conditions, unless the cabinet/panelboard combination is designed and identified by the manufacturer for such conditions.

4.5 Indoor damp locations

Locate the cabinet or provide shielding to prevent moisture and water from entering and accumulating inside. Mount the cabinet with at least 1/4 inch (6 mm) of air space between the cabinet and the wall or other supporting surface.

4.6 Wet locations

Cabinets shall be specifically approved for wet locations. Mount the cabinet with at least 1/4 inch (6 mm) of air space between the cabinet and the wall or other supporting surface.

4.7 Clearance from ceiling

Do not install the cabinet against a non-fireproof ceiling. Maintain at least 3 ft (0.9 m) of clearance between the ceiling and the cabinet unless an adequate fireproof shield is provided.

4. Installation of panelboard cabinets (boxes)

4.8 Space around the cabinet

When selecting a location, provide sufficient access and working space around the cabinet (see Section 110.26 of the National Electrical Code). The width of the working space in front of the panelboard shall be at least 30 in (760 mm), and this space shall not be used for storage. Ensure the working space has adequate lighting and a minimum headroom of 6 ft 6 in (1.98 m). Install the cabinet in an area that is readily accessible and protected from physical damage.

4.9 Mounting of cabinet

The cabinet shall be securely mounted to the supporting surface. Do not rely on wooden plugs driven into masonry, concrete, plaster, or similar materials (see Section 110.13 of the National Electrical Code).

4.10 Flush mounting in wall

Do not install the cabinet in a location where it will be exposed to ambient temperatures above 40 °C (104 °F), corrosive or explosive fumes, dust, vapors, dripping or standing water, abnormal vibration, mechanical shock, high humidity, tilting, or unusual operating conditions, unless the cabinet/panelboard combination is designed and identified by the manufacturer for such conditions.

4.11 Unused openings in cabinet

Choose a dry location for installation or provide shielding to prevent moisture and water from entering and accumulating inside the unit. Mount the cabinet with at least 1/4 in (6 mm) of air space between the cabinet and the wall or other supporting surface.

4.12 Grounding of panelboard cabinets

Cabinets shall be specifically approved for wet locations. Mount the cabinet with at least 1/4 in (6 mm) of air space between the cabinet and the wall or other supporting surface.

INSTALLATION OF CONDUIT AND CONDUCTORS

5. Installation of conduit and conductors

5.1 Conduits installation

Conduits shall be installed to prevent moisture or water from entering and accumulating within the enclosure. Provisions shall be made to protect conductors from abrasion in accordance with Article 312 of the National Electrical Code.

5.2 Machining conduit holes

- 1) Separate the cable entry components to prepare the conduit opening.
(The bolt is a 1/4 in. hex head. Use a 3/8 in. hex socket wrench.)

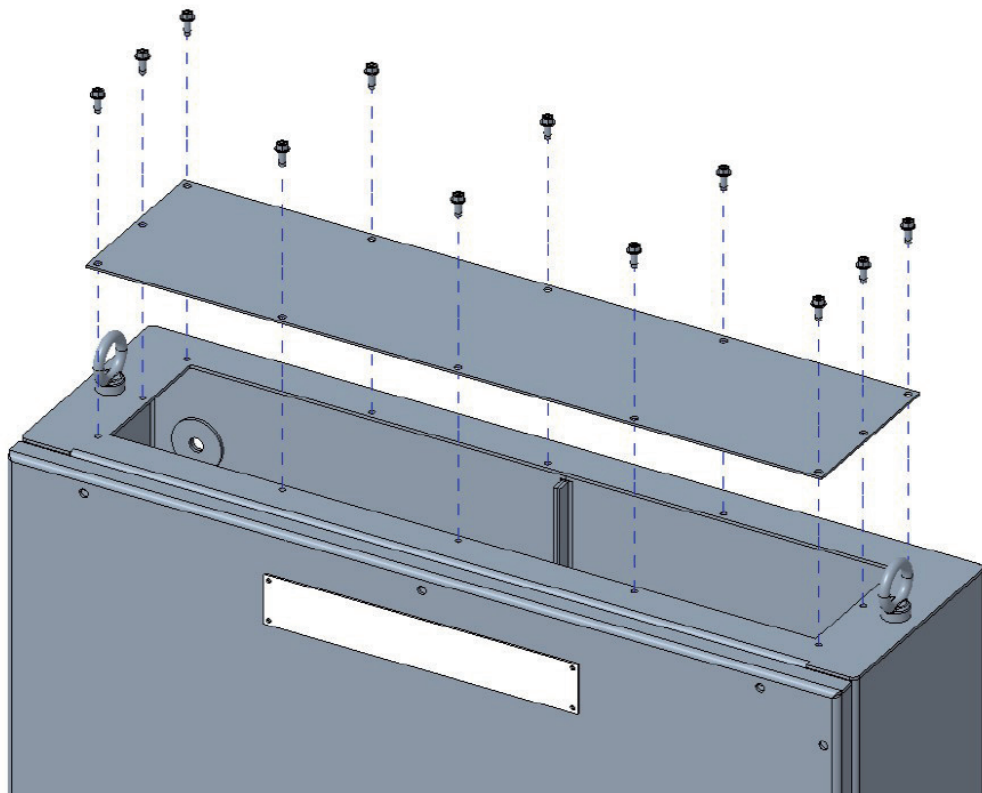

5. Installation of conduit and conductors

5.2 Machining conduit holes

- 2) Machine a conduit hole of the desired size in the separated plate using an appropriate tool. A hydraulic knockout tool or hole cutter is recommended. Follow the tool manufacturer's instructions during use.



- 3) Reassemble the machined components in their original positions.

INSTALLATION OF CONDUIT AND CONDUCTORS

5. Installation of conduit and conductors

5.3 National electrical code, article 300

Refer to the National Electrical Code, Article 300, for proper wiring methods. See Section 6.6 for proper connections.

5.4 Conductor length

Keep conductor lengths to a minimum within the wiring gutter. Excessive conductor length can cause additional heating and may lead to overheating. Conductors shall be long enough to reach the terminal location without placing strain on the terminal.

5.5 Exercise care

Exercise care to maintain the largest practical bending radius of conductors. Otherwise, insulation may be damaged, and terminal connections may become loose. Conductor deflection shall comply with NEC Section 312.6.

5.6 National electrical code, section 725.54

Refer to the National Electrical Code, Section 725.54, for conductor separation requirements for Class 2 and Class 3 remote-control, signaling, and power-limited circuits.

6. Installation of panelboard

6.1 Proper storage

Store the panelboard in a clean, dry location to prevent mechanical damage from personnel in the area.

6.2 Unpacking

Exercise care when unpacking the panelboard to prevent damage and to retain instruction materials and loose parts.

6.3 Inspection

Inspect the panelboard for shipping damage and verify that it is the correct unit for installation in the cabinet.

6.4 Care

Protect the panelboard internal parts from contamination during installation.

6.4.1 Cleaning

Clean the cabinet of all foreign materials. If connection points are spattered with cement, plaster, paint, or other foreign materials, carefully remove them to avoid damaging the plating.



CAUTION

Hydrocarbon spray propellants and hydrocarbon-based sprays or compounds can degrade certain plastics. Contact the panelboard manufacturer before using these products to clean, dry, or lubricate panelboard components during installation or maintenance.

INSTALLATION OF PANELBOARD

6. Installation of panelboard

6.5 Manufacturer's instructions

Carefully follow the manufacturer's instructions and labels.
Check the manual enclosed with the installation parts.

6.6 Line and branch conductors

Connect the line and branch conductors.

6.6.1 Conductors

Use care when stripping insulation from conductors to avoid nicking or ringing the conductor. For aluminum conductors, remove all oxide from the stripped portion and apply an anti-oxide compound.

6.6.1.1 Wiring Gutters

Distribute and arrange conductors neatly within the wiring gutters (see Section 5).

6.6.1.2 Types and Temperature Ratings

Exercise care to ensure that the types and temperature ratings of conductors installed in the panelboard are suitable for use with the provided terminals.

6.6.1.3 Tighten All Terminals

Use the manufacturer's torque values. (see 7.1)

6.7.1 Equipment Grounding Conductors

Where separate equipment grounding conductors are used, prepare them in accordance with Section 6.7.1 and connect them to the equipment grounding terminal bar. Verify that the terminal bar is securely bonded to the cabinet or panelboard frame, and that it is not connected to the neutral bar except at service equipment (per Section 250.28 of the National Electrical Code) or at separately derived systems (per Section 250.30 of the National Electrical Code).

※ Note:

An equipment grounding terminal bar is not always required. For example, it is not required when a properly installed metallic raceway is used as the equipment grounding path, or when the grounded conductor terminals (neutral bar) comply with the conditions described in the last sentence of Section 408.40 of the National Electrical Code.

6.7 Panelboard grounding

6. Installation of panelboard

6.8 Proper type or class and rating

When installing circuit breakers or fuses, ensure that they are of the proper type or class and rating.

6.9 Debris

Clean the cabinet of all debris accumulated during panelboard installation (see Section 6.4.1).

6.10 Steps in section 7

Upon completion of the job, perform the steps in Section 7, then install the cabinet front (see Section 8).

STEPS TO TAKE BEFORE ENERGIZING

7. Steps to take before energizing

7.1 Accessible electrical connections

Tighten all accessible electrical connections to the manufacturer's torque specifications.

7.1.1 Mechanical LUG for Neutral KIT and Grounding Bar

Cat. No	Cable Size (CU)	AWG/MCM	Torque	
			lb-in.	N-m
LPB-125	6 - 2/0	6 - 4	110	12.4
		3 - 0	150	16.9
		1/0 - 2/0	180	20.3
LPB-150	2 - 4/0	2 - 1	150	16.9
		1/0 - 2/0	180	20.3
		3/0 - 4/0	250	28.2
LPB-250	1 - 300	1	150	16.9
		1/0 - 2/0	180	20.3
		3/0 - 4/0	250	28.2
		250 - 300	325	36.7
LPB-400S	1/0 - 600	1/0 - 300	400	45.0
		350 - 600	530	60.0
LPB-400D	(2) 3 - 4/0	3 - 1	150	16.9
		1/0 - 2/0	180	20.3
		3/0 - 4/0	250	28.2
LPB-800D	(2) - 3/0 - 600	3/0 - 4/0	250	28.2
		250 - 400	325	36.7
		500 - 600	375	42.4
LPB-800T	(3) 300 - 400	300 - 400	500	56.5
LPB-1200	(4) 3/0 - (4) 350	(4) 3/0 - (4) 350	400	45.0

Cat. No	Cable Size (CU)	AWG/MCM	Torque	
			lb-in.	N-m
LPB-125	Large Hole 8 - 1/0	8	40	4.5
		6 - 4	45	5.1
		2 - 1/0	50	5.7
	Small Hole 14 - 6	14 - 10	15	1.7
		8 - 6	25	2.8

7. Steps to take before energizing

7.1 Accessible electrical connections

7.1.2 Molded Case Circuit Breaker

7.1.2.1 MCCB LUG

Cat. No	Cable Size (CU)		Torque	
			lb-in.	N-m
UTE100	CU, 75 °C	14 - 10	31.9	3.6
		8	39.8	4.5
		6 - 3	47.8	5.4
UTS150	CU, 75 °C	14	36.2	4.1
		12 - 10	47.8	5.4
		8 - 2/0	133.6	15.1
UTS250	CU, 75 °C	1/0 - 4/0	283.2	32
		250 - 300	389.4	44
UTS400	CU, 75 °C	1/0 - 300	358.5	40.5
		350 - 600	478	54
UTS600	CU, 75 °C	2/0 - 350	358.5	40.5
UTS800	CU, 75 °C	3/0 - 300	398.3	45
UTS1200	CU, 75 °C	3/0 - 350	398.3	45

7.1.2.2 MCCB Terminal

Cat. No	Torque	
	lbf.in	N.m
UTE100	15.2	1.72
UTS150	50	5.64
UTS250	117.8	13.3
UTS400	234.8	26.5
UTS600	234.8	26.5
UTS800	212.7	24
UTS1200	425.3	48

7.1.3 Busbars

Torque values for busbar connections are as follows.

Type	kgf.cm	N.m	lbf.in
M6	101.8	10.0	88.5
M8	245	24.0	213
1/4 in. - 20	150	14.7	130

STEPS TO TAKE BEFORE ENERGIZING

7. Steps to take before energizing

7.2 Blocks and packing materials

Remove all blocks and packing materials used for shipment from all component devices and the panelboard.

7.3 Switches, circuit breakers, and other operating mechanisms

Manually operate all switches, circuit breakers, and other operating mechanisms to ensure they move freely. Check the integrity of all electrical and mechanical interlocks and padlocking mechanisms. For key-interlocked systems, ensure that only the required number of keys are accessible to the operator.

7.4 Short circuits and ground faults

Conduct an insulation resistance test, phase-to-ground and phase-to-phase, with switches or circuit breakers in both the open and closed positions to verify the system is free from short circuits and ground faults. If the resistance is less than 1 megohm while testing branch circuit devices in the open position, investigate the system. If low readings persist after investigation and correction, contact the manufacturer. Some electronic equipment (metering, TVSS, etc.) may be damaged by this test. Refer to the manufacturer's equipment markings for guidelines.

7.5 Ground fault protection system

Test the ground fault protection system (if provided) according to the manufacturer's instructions. See Section 230.95 of the National Electrical Code and NEMA Standards Publication PB 2.2, Application Guide for Ground Fault Protective Devices for Equipment.

7.6 Adjustable time current trip device settings

Set any adjustable time-current trip device settings to the proper values.

※ **Note:**

Damage from overcurrent can be minimized if the devices used for overload and short-circuit protection are properly selected, installed, and maintained.

Set protection devices to operate instantaneously (that is, without intentional time delay) at 115 % percent of the highest phase current likely to occur due to any anticipated motor starting or welding currents.

7.7 Grounding connections

Verify that all grounding connections are properly made. If the panelboard is used as service equipment, ensure that the neutral, if present, is properly bonded to the cabinet.

7. Steps to take before energizing

7.8 Foreign material

Remove all foreign material from the panelboard and cabinet before installing the cabinet front. Ensure that all deadfront shields are properly aligned and tightened. Install the cabinet front in accordance with Section 8.

INSTALLATION OF CABINET FRONT

8. Installation of cabinet front

8.1 Cabinet front or trim package

The cabinet front or trim package is designed to protect the front from damage during shipment and handling.

8.2 Unpacking

Exercise care when unpacking and handling the cabinet front.

8.3 Covers and doors

Install covers and close doors.
Ensure that no conductors are pinched and that all enclosure parts are properly aligned and tightened.

8.4 Touch-up

Apply a suitable paint or other corrosion-resistant finish to any surfaces where the finish is damaged.

8.5 Front alignment

The cabinet front may include an adjustment mechanism to align it squarely with the building, even if the cabinet is slightly out of plumb.

9. ENERGIZING EQUIPMENT



WARNING

Hazardous voltages in electrical equipment can cause severe personal injury or death. Energizing a panelboard for the first time after initial installation or maintenance is potentially dangerous.

9.1 Qualified personnel

Only qualified personnel should energize equipment for the first time. If short-circuit conditions caused by damage or poor installation practices have not been detected during the procedures specified in Section 7, serious personal injury or equipment damage can occur when power is turned on.

9.2 Load on the panelboard

Ensure there is no load on the panelboard when it is energized. Turn off all downstream loads.

9.3 Energized in sequence

Energize the equipment in sequence, starting at the source end of the system and working toward the load end. Energize the main devices first, then the feeder devices, and finally the branch-circuit devices. Turn the devices on with a firm, positive motion.

9.4 Loads such as lighting circuits, contactors, heaters, and motors

After all main, feeder, and branch-circuit devices have been closed, loads such as lighting circuits, contactors, heaters, and motors may be turned on.

MAINTENANCE

10. Maintenance

10.1 Maintenance program

A maintenance program for panelboards should be conducted on a regularly scheduled basis in accordance with the following:

10.2 Panelboard which has been carrying its regular load for at least 3 hours

A panelboard that has been carrying its normal load for at least 3 hours prior to inspection should be field-tested by feeling the deadfront surfaces of circuit breakers, switches, interior trims, doors, and enclosure sides with the palm of the hand. If the temperature of these surfaces prevents contact for at least 3 seconds, this may indicate a problem, and further investigation is necessary. Thermographic (infrared) scanning is a useful method for investigating thermal performance.



WARNING

Hazardous voltages in electrical equipment can cause severe personal injury or death. Unless otherwise specified, inspection and maintenance should be performed only on panelboards whose power has been turned off, disconnected, and electrically isolated so that no accidental contact can be made with energized parts. Follow all manufacturer's warnings and instructions.

※ Safety

Follow related work practices as described in NFPA 70E at all times.



CAUTION

Hydrocarbon spray propellants and hydrocarbon-based sprays or compounds can degrade certain plastics. Contact the panelboard manufacturer before using these products to clean, dry, or lubricate panelboard components during installation or maintenance.

10.3 Inspect panelboard once each year

Inspect the panelboard annually or after any severe short-circuit event.

10.4 Accumulation of dust and dirt

If dust or dirt has accumulated, clean the panelboard using a brush, vacuum cleaner, or clean, lint-free rags. Avoid blowing dust into circuit breakers or other components. Do not use a blower or compressed air.

10. Maintenance

10.4 Accumulation of dust and dirt

10.4.1 Visible Electrical Joints and Terminals

Inspect all visible electrical joints and terminals in the bus and wiring system carefully.

10.4.2 Conductors and Connections

Visually check all conductors and connections, ensuring that components are clean and secure. Loose or contaminated connections increase electrical resistance, which can cause overheating. Overheating is indicated by discoloration or flaking of insulation or metal parts. Pitting or melting of connecting surfaces is a sign of arcing due to a loose or poor connection.

Parts showing evidence of overheating or looseness should be cleaned and re-torqued, or replaced if damaged.

Tighten bolts and nuts at bus joints to the manufacturer's torque specifications. Refer to Section 7.1.1.



CAUTION

Do not remove plating from aluminum parts in joints or terminations.
Damage to plating can cause overheating. Replace any damaged aluminum parts.

10.4.4 Plug Fuses

Re-tighten plug fuses.

10.4.5 Conditions Which Caused Overheating

Ensure that all conditions that caused overheating have been corrected.

10.5 Proper ampere, voltage, and interrupting ratings

Check circuit breakers, switches, and fuses to verify they have the proper ampere, voltage, and interrupting ratings.

Do not use non-current-limiting devices as replacements for current-limiting devices.

Never attempt to defeat rejection mechanisms provided to prevent installation of an incorrect class of fuse.

10.5.1 Mechanisms Free and in Proper Working Order

Operate each switch or circuit breaker several times to ensure all mechanisms are free and functioning properly.

Replace components as required.

See NEMA AB-4 for maintenance of molded-case circuit breakers.

MAINTENANCE

10.6 Operation of all mechanical components

10. Maintenance

Check the operation of all mechanical components.
Replace components as required.

10.6.1 Switch Operating Mechanisms

Exercise the switch operating mechanisms and external operators of circuit breakers to ensure they operate freely through their full on and off positions.

10.6.2 Integrity of Electrical and Mechanical Interlocks

Check the integrity of all electrical and mechanical interlocks and padlocking mechanisms.
For key-interlocked systems, ensure that only the required number of keys are accessible to the operator.

10.6.3 Missing or Broken Parts

Whenever practical, inspect all devices for missing or broken parts, proper spring tension, free movement, corrosion, dirt, and excessive wear.

10.6.4 Manufacturer's Instructions

Adjust, clean, lubricate, or replace parts according to the manufacturer's instructions.

10.6.4.1 Clean Nonmetallic Light Grease or Oil

Use clean, nonmetallic light grease or oil as instructed.

10.6.4.2 Molded Case Circuit Breakers

Do not oil or grease parts of molded case circuit breakers.

10.6.4.3 Clean, Light Grease

If no instructions are provided for the devices, sliding copper contacts, operating mechanisms, and interlocks may be lubricated with clean, light grease.

10.6.4.4 Excess Lubrication

Wipe off excess lubrication to prevent contamination.



CAUTION

Hydrocarbon spray propellants and hydrocarbon-based sprays or compounds can cause degradation of certain plastics. Contact the panelboard manufacturer before using these products to clean, dry, or lubricate panelboard components during installation or maintenance.

10. Maintenance

10.6 Operation of all mechanical components

10.6.5 Accessible Copper Electrical Contacts, Blades, and Jaws

Clean and dress all readily accessible copper electrical contacts, blades, and jaws according to the manufacturer's instructions as needed during inspection.

10.7 Damaged insulating material and assemblies

Inspect insulating materials and assemblies, and replace any that are damaged or where sealing compounds have deteriorated.

10.8 Moisture, signs of previous wetness or dripping

Check for moisture or signs of previous wetness or dripping inside the cabinet.

※ **Note:**

Be aware that condensation in conduits or dripping from external sources can cause panelboard malfunctions.

10.8.1 Conduits with Dripping Condensation

Seal any conduits with dripping condensation and provide a path for further condensation to drain away from the panelboard.

10.8.2 Cracks or Openings

Seal any cracks or openings that have allowed moisture to enter the enclosure. Eliminate the source of dripping on the enclosure or any other source of moisture.

10.8.3 Insulating Damp or Wet Material

Replace, or thoroughly dry and clean, any insulating material that is damp, wet, or shows an accumulation of deposits from previous wetness.

10.8.4 Component Devices Which Show Evidence of Moisture Damage

Inspect all component devices. Replace any device that shows evidence of moisture damage or has been subjected to water damage or flooding. Additional information can be found in the NEMA document "Guidelines for Handling Water-Damaged Electrical Products".

MAINTENANCE

10. Maintenance

10.9 Before cleanup and corrective action is attempted

In the event of water damage (e.g., flooding or sprinkler discharge), consult the manufacturer before attempting cleanup or corrective action.

10.10 Severe electrical short circuit

If a severe electrical short circuit has occurred, excessive currents may have caused structural component or bus/conductor damage due to mechanical distortion, thermal effects, metal deposits, or smoke. Examine all devices and bus supports for cracks or breakage. Consult the manufacturer before attempting cleanup or corrective action.

10.11 Ground fault protection system

Test the ground fault protection system (if provided) in accordance with the manufacturer's instructions. See Section 230.95 of the National Electrical Code and NEMA Standards Publication PB 2.2, Application Guide for Ground Fault Protective Devices for Equipment.

10.12 Insulation resistance

Check insulation resistance (see 7.4) under any of the following conditions:

10.12.1 Severe Short Circuit

If a severe short circuit has occurred (see 10.10), inspect the panelboard for damage.

10.12.2 Parts Replaced

If parts must be replaced or insulating surfaces cleaned, follow the manufacturer's instructions.

10.12.3 Panelboard Exposed to High Humidity

If the panelboard has been exposed to high humidity, condensation, or dripping moisture, inspect and dry all affected components before energizing.

11. Permissible loading of panelboards

11.1 National electrical code

In accordance with the National Electrical Code, normal continuous loads (3 hours or more) on panelboard circuits should not exceed 80 % of the rating of the overcurrent protective device, unless the device is marked as suitable for continuous duty at 100 % of its rating.

11.2 Harmonics in electrical system

Certain types of electrical equipment may introduce harmonics into the electrical system, which can cause overheating. Consider this effect when determining panelboard loading.

**LS ELECTRIC America Inc. Chicago Head Office**

625 Heathrow Dr, Lincolnshire, IL 60069, USA

Tel: 1-224-352-2265 E-Mail: sales.us@lselectricamerica.com

Headquarter

127 LS-ro (Hogye-dong) Dongan-gu, Anyang-si, Gyeonggi-Do, 14119, Korea

Seoul Office

LS Yongsan Tower, 92, Hangang-daero, Yongsan-gu, Seoul, 04386, Korea

TEL: 82-2-2034-4916, 4684, 4429

China

LS ELECTRIC (Dalian) Co., Ltd.

+86-411-8730-7560

china.dalian@lselectric.com.cn

LS ELECTRIC (Wuxi) Co., Ltd.

+86-510-8534-6666

china.wuxi@lselectric.com.cn

LS ELECTRIC (Lishui) Co., Ltd.

+86-133-6207-7980

china.lishui@lselectric.com.cn

Shanghai Office

+86-21-5237-9977

china@lselectric.com.cn

Beijing Office

+86-10-5095-1631

china@lselectric.com.cn

Guangzhou Office

+86-20-3818-2883

china@lselectric.com.cn

Qingdao Office

+86-532-8501-2065

china@lselectric.com.cn

Chengdu Office

+86-28-8670-3201

china@lselectric.com.cn

Nanjing Office

+86-25-8467-0005

china@lselectric.com.cn

India

India Office

+91-80-6142-9108

info_india@ls-electric.com

Indonesia

PT. LS ELECTRIC INDONESIA

+62-21-2933-7614

indonesia@ls-electric.com

Italy

Italy office

+39-030-8081-833

italia@ls-electric.com

Japan

LS ELECTRIC Japan Co., Ltd.

+81-3-6268-8241

japan@ls-electric.com

Tokyo Office

+81-3-6268-8241

tokyo@ls-electric.com

Netherlands

LS ELECTRIC Europe B.V.

+31-20-654-1424

europartner@ls-electric.com

Russia

Moscow Office

+7-499-682-6130

info@lselectric-ru.com

Singapore

Singapore Office

+65-6958-8162

singapore@ls-electric.com

Spain

LS ELECTRIC IBERIA S.L.U.

+34-910-28-02-74

iberia@ls-electric.com

Thailand

Bangkok Office

+66-2-128-0295

thailand@ls-electric.com

Türkiye

LS ELECTRIC Türkiye Co., Ltd.

+90-212-806-1252

turkiye@ls-electric.com

U.A.E

LS ELECTRIC Middle East FZE (Dubai)

+971-4-886-5360

middleeast@ls-electric.com

USA

LS ELECTRIC America Inc.

+1-800-891-2941

sales.us@lselectricamerica.com

LS ENERGY SOLUTIONS LLC

+1-980-221-0654

cmfeldman@ls-es.com

MCM Engineering II

+1-435-865-0125

sales.us@lselectricamerica.com

America Western Office

+1-949-333-3140

america@ls-electric.com

America Bastrop Campus

+1-224-352-2265

sales.us@lselectricamerica.com

Vietnam

LS ELECTRIC Vietnam Co., Ltd.

+84-222-2221-110

vietnam@ls-electric.com

Hanoi Sales Office

+84-24-6275-8054

vietnam@ls-electric.com

Ho Chi Minh Sales Office

+84-3823-7890

vietnam@ls-electric.com

Specifications in this catalog are subject to change without notice due to continuous product development and improvement

© 2024. 02 LS ELECTRIC Co., Ltd. All rights reserved. / English (02) 2026. 05 Staffcom

www.LSElectricAmerica.com