

Beyond X™

Susol
UL LV Switchgear
Installation Operation Maintenance Manual



LS ELECTRIC

Susol UL Low Voltage Switchgear Installation Operation Maintenance Manual



LSELECTRIC

Table of content

1. SWITCHGEAR DESCRIPTION

- 1.1 Panel description 10
 - 1.1.1 Single line diagram for the each CB-compartment 10
- 1.2 Applied standards 11
- 1.3 Environmental and operating conditions 11
- 1.4 Technical data 11
- 1.5 Name plate 11
- 1.6 Dimension and weights 10
- 1.7 Intended use 12
- 1.8 Disposal after the end of service life 12

2. PACKING 13

3. RECEIVING, HANDLING & STORAGE

- 3.1 Receiving 14
- 3.2 Handling 14
- 3.3 Storage 16
 - 3.3.1 Storage method 16
 - 3.3.2 Check point for storage 17
- 3.4 Storage guarantee 17

4. INSTALLATION

- 4.1 Installation 18
- 4.2 Foundations 18
- 4.3 Placement 20

5. Accessing the main circuit compartments

- 5.1 Accessing cable compartment 21
 - 5.1.1 Removing cable compartment cover 21
- 5.2 Accessing the ACB compartment 22
 - 5.2.1 Opening and closing the cover of the ACB compartment 22
- 5.3 Removing and Inserting ACB from the panel 23
 - 5.3.1 Removing and Inserting ACB using Hoist 23
 - 5.3.2 Removing and Inserting ACB using ACB Lifter 24
- 5.4 Accessing busbar compartment 25
 - 5.4.1 Accessing busbar compartment through top cover 26
 - 5.4.2 Accessing busbar compartment through cable compartment 26

6. Assembly of SUSOL UL LV SWGR

6.1 Safety provisions	29
6.2 Important instructions for assembly	29
6.3 Assembly	29
6.3.1 Indoor Assembly	29
6.3.2 Main Bus connection between sections	30
6.3.3 Control wiring Interconnection	32
6.3.4 Ground bus	33
6.3.5 Current Transformers	33
6.3.6 Fuse	33
6.3.7 Key Interlocks(If provided)	33
6.3.8 Primary Cables Connection	33
6.3.9 Bus Duct Connections	34
6.3.10 Connection of Control Cable	34
6.3.11 Cleaning	34
6.3.12 Pre-operational Testing and Inspections	35
6.3.13 Primary circuits	35
6.4 Requirements regarding the switchgear room	35
6.5 Fastening screws for connecting with other panels	37
6.6 Top cover assembly	37
6.7 Busbar assembly	39
6.8 Mounting the earth bus	40

7. OPERATION

7.1 Commissioning	41
7.1.1 Preparatory work	41
7.1.2 Start-up	42
7.2 Switching operation	43
7.2.1 Installation of switching operation	43
7.2.2 Draw-in operation	44
7.2.3 Draw-out operation	46
7.3 Space Heater	47
7.4 Busbar	47
7.4.1 Accessing Busbar	47
7.4.2 Busbar inspection and cleaning	47
7.5 Ground&Test devices	47

Table of content

- 8. TESTING AND INSPECTION 48**

- 9. SAFETY PRECAUTIONS**
 - 9.1 Handling Electrical Machinery and Apparatus 49
 - 9.1.1 General Precautions 49
 - 9.1.2 Precautions for Hot-line Work 51
 - 9.1.3 Guidelines for Fire Extinguishing 52
 - 9.1.4 Maintenance and Inspection of ACB 52
 - 9.1.5 Precautions for ACB Operation 53
 - 9.1.6 Precautions for Current & Voltage transformer Operation 53
 - 9.1.7 Precautions for Changing Fuses 54
 - 9.1.8 Other Precautions 54
 - 9.2 Electrical Shock Prevention 55
 - 9.2.1 General Information on Electric Shock 55
 - 9.2.2 Prevention of Electric Shock 55

- 10. MAINTENANCE**
 - 10.1 General 56
 - 10.2 Classification of Periodic Inspection 56
 - 10.2.1 Visual inspection 58
 - 10.2.2 Planned inspections 58
 - 10.2.3 Planned inspections routine 58
 - 10.2.4 Monthly inspections 58
 - 10.2.5 Annual inspections 58
 - 10.3 Maintenance and Repair of Equipment 59
 - 10.3.1 Isolating procedure of the main bus bar for SWGR 59
 - 10.3.2 General safety procedures 59
 - 10.4 Repair of Surface Damage 60
 - 10.5 Table of Scheduled Maintenance 60
 - 10.6 Preventive Maintenance Procedures of Various Equipment 61
 - 10.6.1 Switchgear 61
 - 10.6.2 Air Circuit Breaker and Electromagnetic Contactor 61
 - 10.6.3 Current Transformer (CT) 64
 - 10.6.4 Switch, Contactor 65
 - 10.6.5 Busbar 66

- 11. TREATMENT**
 - 11.1 Daily and Instant Treatment 67
 - 11.2 Periodical Treatment 68

WARNINGS

WARNINGS

Low voltage switchgear is safe and effective when proper precautions are taken.

When hazardous voltage and energy levels generate, it may cause death or injury if precautions are not followed

1. Never work around a live or energized bus. Do not remove bolted cover, bolted doors and bolted access plates when the equipment is energized. The live bus is enclosed behind metal panels and these panels should not be removed unless the bus is de-energized.
2. Never use a circuit breaker rated over a maximum voltage from the equipment. Never use a lower interrupting rating than the system is designed for.
3. Only qualified personnel should maintain or operate switchgear. Maintenance personnel should be qualified to work with low voltage equipment and familiar with switchgear in general. Operators should be trained in the proper use of switchgear and its components. Both should have electrical shock and burn medical training.
4. Do not touch shutters when switchgear is energized. Voltage flows behind the shutters. They are automatically closed when breaker is removed, to prevent accidental contact.
5. Do not insert partially disassembled breakers, test breakers, ground and test devices, or other items into an energized cell. Tests using these devices must only be conducted when main bus is de-energized.
6. Never manually close a circuit breaker into a live circuit.
7. Never disconnect or open the secondary circuit of current transformers when they are on energized circuits. Voltages will develop between contacts. Keep spare current transformers shorted on their secondary circuit.
8. When circuits are opened for maintenance, repair or inspection, lock circuit breakers or disconnect switches in the open position and tag or mark to let others know that it is locked open for safety purposes. In addition, bus should be grounded to prevent accidents from accidental closure or back feeding.

1. SWITCHGEAR DESCRIPTION

This instruction manual describes general and basic matters required for packing, storage, installation, operation, and inspection of the product to secure safety of operator and optimal operation of the product.

The manual shall be known well in parallel with relevant drawings and documents provided additionally.

Metal-enclosed switchgear is a form of protection for power distribution systems.

Properly designed switchgear will limit the extent of outages, prevent serious fault current damage, and protect lives and property all at a reasonable cost.

The major elements in metal-enclosed switchgear are the circuit breakers, bus and cable, relays, control equipment and the metal-enclosed structure itself.

All elements have different functions but their combined purpose is to deliver power with minimum outages while at the same time reacting quickly to interrupt short circuit currents before serious damage can occur to other devices.

Circuit breakers are the actual circuit interruption devices. In a typical system each feeder will have a separate circuit breaker while each incoming line will also have a breaker. These are designed to limit the fault current through them while normal currents flow at the same time.

Bus and cables are the actual method of power distribution because current flows through them, and they are insulated from the ground.

Relays are the sensors of the system. They react to voltage, current, frequency, or other system conditions. When those conditions match predetermined levels the relays will initiate tripping of the appropriate breakers.

Control equipment is used to check or control system parameters. Lights indicate if breakers are open or closed. Control switches will open or close breakers, enable or disable relays or devices, and determine operational modes [i.e. remote or manual or automatic.].

Meters will show voltage, currents, frequencies, or other relevant parameters.

The structure of the switchgear serves multiple functions. It protects all the elements from damage or environmental influences. It protects humans from harmful voltages or energies which may cause potentially electric injury. It also isolates sections of the switchgear from each other.

Finally, it supports the various devices and provides a mounting position for them.

The equipment is designed for liquid exposure; however, liquid can potentially destroy the integrity of the insulation and therefore should be avoided.

SWITCHGEAR DESCRIPTION

1. SWITCHGEAR DESCRIPTION

1.1 Panel description

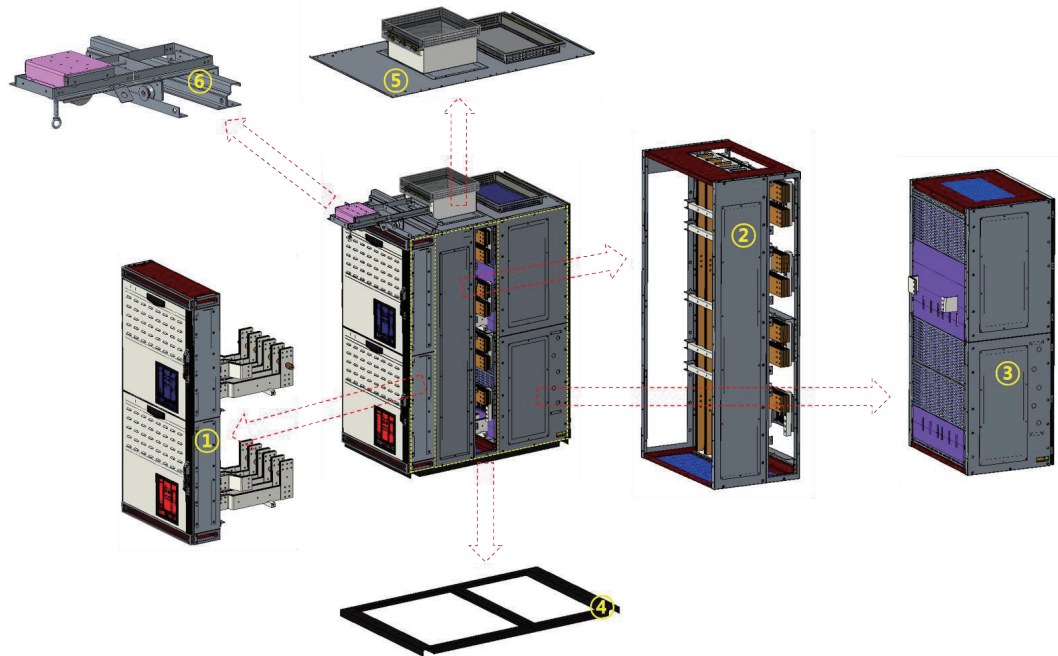

< Fig. 1.1 >

- | | |
|----------------------|--------------------|
| 1. CB compartment | 2. BUS compartment |
| 3. Cable compartment | 4. Channel base |
| 5. Top cover | 6. ACB hoist |

1.1.1 Single line diagram for the each CB-compartment.

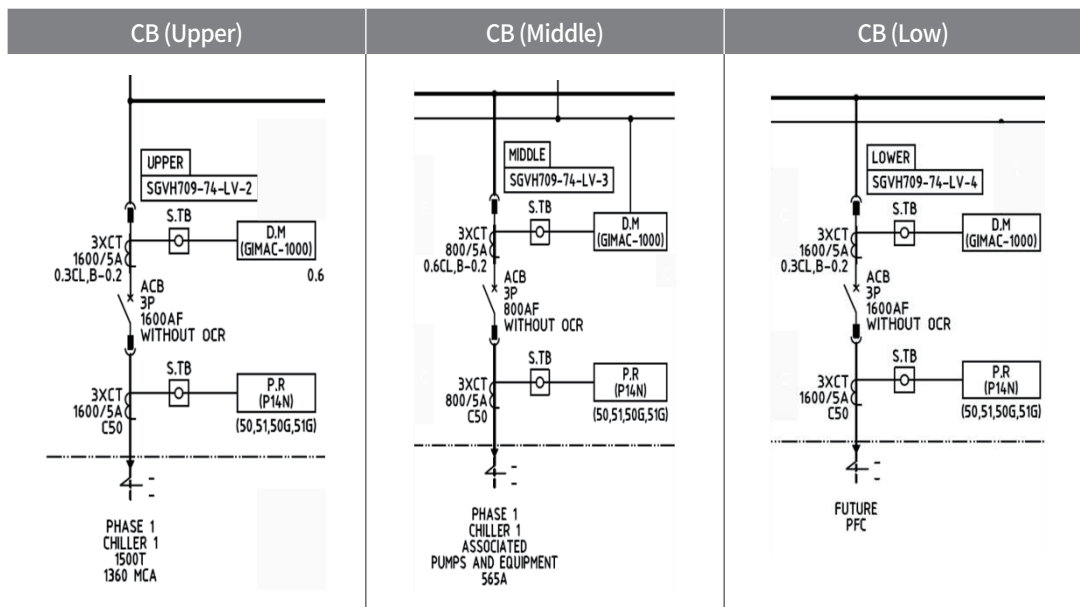

1. SWITCHGEAR DESCRIPTION

1.2 Applied standards

Designation	IEEE standard
Switchgear	IEEE Std C37.20.1 2015
Internal arc classification (IAC)- Type 2B	IEEE Std C37.20.7 2017
Safety	UL 1558 Standard for safety

1.3 Environmental and operating conditions

Ambient conditions in accordance with IEEE C37.20.1	
Min./max. ambient temperature	-22°F and +104°F(-30°C /+40°C)
Installation altitude above sea-level	≤ 6600ft (2000m)
The effect of solar radiation is not significant.	

※ Note. If under unusual service conditions, please contact the manufacturer (LS ELECTRIC).

1.4 Technical data

Technical data	
Rated voltage Ur [V]	635
Rated power frequency withstand voltage Ud [Kv]	2.2
Rated normal current, Horizontal(main) busbar Ir [A]	≤ 6000A
Rated normal current, Vertical (Distribution) busbar Ir [A]	≤ 6000A for SWGR
Rated short-time current Ik of busbar [kA]	65kA/1sec, 85kA/1sec, 100kA/1sec
Arc resistance performance[kA]	≤ 100 (0.5 s)
Rated frequency [Hz]	60

1.5 Name plate

The nameplate on the panel specifies essential technical data. They are mounted on the cover of the switching device compartment and the switching device compartment.

The following data on the nameplate are relevant in case of any queries:

- Manufacturer's name and address
- Manufacturer's type designation
- Manufacturer's identification reference
- Rated maximum voltage
- Rated power frequency
- Rated continuous current
- Rated short-circuit withstand current
- Date of manufacture
- Instruction manual number

[Sample nameplate]

METAL-ENCLOSED SWITCHGEAR	
LV SWGR UNDER 1000V	
TYPE	SUSOL UL LV Switchgear
MANUFACTURER'S TYPE DESIGNATION	USG-50N85E4025
MANUFACTURER'S NAME	LS ELECTRIC Co., Ltd.
MANUFACTURER'S ADDRESS	95 BAEKBONG-RO HEUNGDEOK-GU CHEONGJU-SI CHUNGCHEONGBUK-DO 361-720 KOREA
RATED MAXIMUM VOLTAGE	508V
RATED POWER FREQUENCY	60 Hz
RATED CONTINUOUS CURRENT	4000A
RATED SHORT-CIRCUIT WITHSTAND CURRENT	85 kA
DATE OF MANUFACTURE	2020.12
INSTRUCTION MANUAL NUMBER	W44336776_UL
<div style="border: 1px dashed black; padding: 5px; display: inline-block;"> UL 인증 Sticker 35X15 </div>	
 MADE IN KOREA	

SWITCHGEAR DESCRIPTION

1. SWITCHGEAR DESCRIPTION

1.6 Dimensions and weight

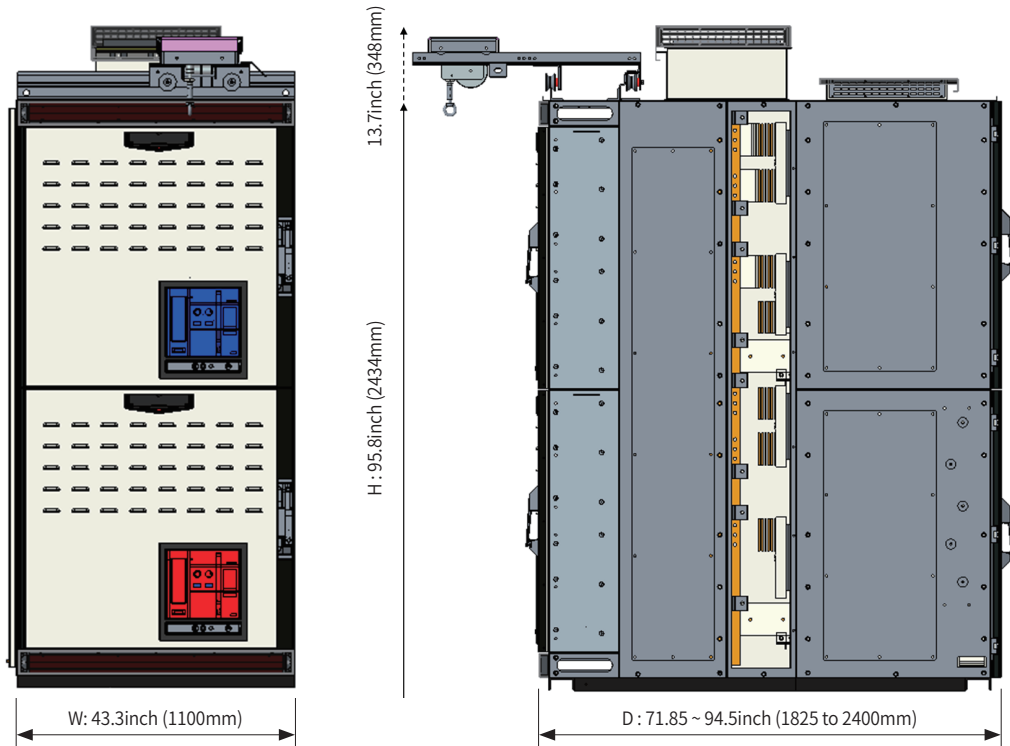

< Fig. 1.2 >

Maximum weight ($\leq 2500\text{kg}$)

- With Air Circuit Breaker
- Without packing
- The bus bars have been taken into consideration with a maximum weight at 6000A
- Without electric device in LV comp.

1.7 Intended use

UL Low-voltage switchgear units are exclusively intended for switching and distributing electrical energies. They may only be used in the scope of the specified standards and the switchgear-specific technical data. Any other utilization constitutes improper use and may result in dangers and damage.

Liability Disclaimers

The manufacturer shall not be held responsible for damage which occurs if:

- Instructions in this manual are not complied with;
- The switchgear is not operated according to its intended use (see above);
- The switchgear is assembled, connected or operated improperly;
- Accessories or spare parts that were used are not approved by the manufacturer;
- The switchgear is converted without the manufacturer's approval, or if inadmissible parts are added. No liability is accepted for parts provided by customers, e. g. power cables.

1.8 Disposal after the end of service life

Upon request, a material and recycling data sheet is available for disposal of switchgear UL Low-Voltage at the end of its service life.

Disposal is performed as a service by the manufacturer's service Center and is subject to a fee.

2. PACKING

The water proof papers are placed in the bottom.

The silica gel bags are put in each unit and enclosure in order to keep them dry. e.g. approx. 10kg per panel

Note the warning and caution signs/labels printed on the crate. Lifting angles are bolted on the top of the LV Switchgear. Use them to lift and transfer the crate in accordance with lifting marks on the crate before the unpacking.

It is recommended that LV Switchgear is moved, without being unpacked, to the place where it will be installed. To move the LV Switchgear after the unpacking, use rolls of small diameter if a crane is not available.

During transportation, special care is required to make sure that the Switchgear does not fall.

The packing method changes in particular cases. Example: Long-term storage.

RECEIVING, HANDLING & STORAGE

3. RECEIVING, HANDLING & STORAGE

Before switchgear is shipped, it is assembled as much as possible, then dispatched to the port.

Hardware, small parts, and brackets are boxed and shipped with the switchgear assemblies. Breakers, batteries, and other major components are usually shipped in their own cartons. Cartons, crates, and boxes are tagged to ease the receiving and assembly.

3.1 Receiving

Once switchgear arrives, inspect the equipment for any damage. If there is any shipping damage, a claim should be filed with the shipping company. Please notify a manufacturer representative as soon as possible.

Carefully look at the packing list to assure all parts have arrived. Note that small items may be packed with larger ones; this will be noted on the shipping documentation.

3.2 Handling



WARNING

Make sure the rope or chain is strong enough to bear the weight of the panel. Comply with the relevant provisions for hoisting equipment.



WARNING

On lowering the panels, make sure that the supporting platform is sufficiently stable and even.



WARNING

Risk of accidents. Pay attention to floor openings!

Before handling, refer to the drawings for approximate weight of shipping sections. Care should be taken to avoid damaging the switchgear during handling operations. Use rated equipment only for lifting the weights involved, and skilled crews with heavy lifting of large electrical equipment.

Prior to uncrating, the equipment may be moved by a crane using slings under the crate. Rollers under crate skids would also be an acceptable method of moving the switchgear section.

3. RECEIVING, HANDLING & STORAGE

3.2 Handling

After uncrating the switchgear shipping sections should be moved by cranes using chain and spreader bars. Breakers generally have their own lifting eyes.

Dragging or skidding switchgear along the ground may damage foundations. Accordingly, there could be damage to the exterior and functions.

Improper lifting or failure to use spreader bars may cause damage to the enclosure by applying a compressive lateral force. Improperly rated lifting equipment or untrained crews may drop switchgear which causes breakage, warpage and misalignment.

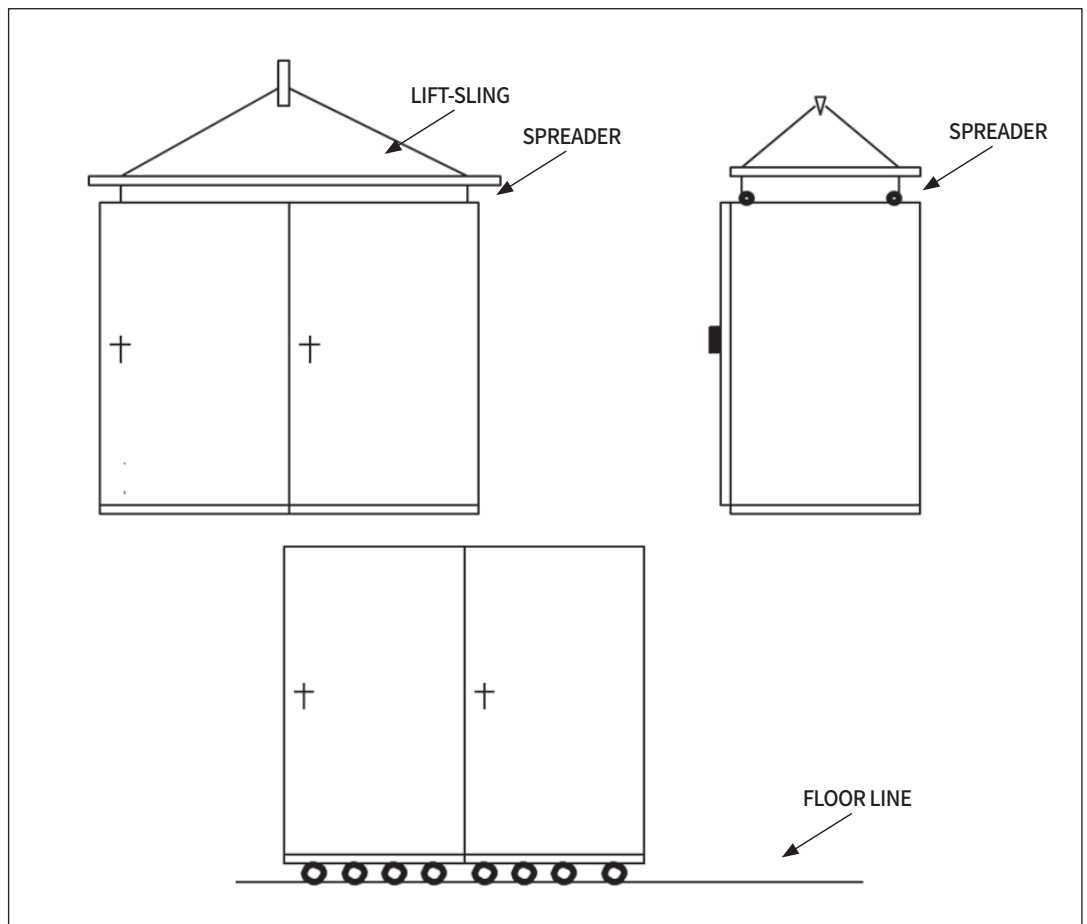

< Fig. 3.1. RECOMMENDED METHOD OF IN - DOOR EQUIPMENT >

For movement in this direction only, use rollers
(Each roller must support the front, middle, rear floor channels)

RECEIVING, HANDLING & STORAGE

3. RECEIVING, HANDLING & STORAGE

3.2 Handling

Transportation of panel by means of a crane

- Attach the crane straps in the lifting angle on top of the panel (Fig. 3.2).
Make sure to leave a minimum height of 1 m (Fig. 3.3).
- Carefully lift the panel and deposit it at the intended location.

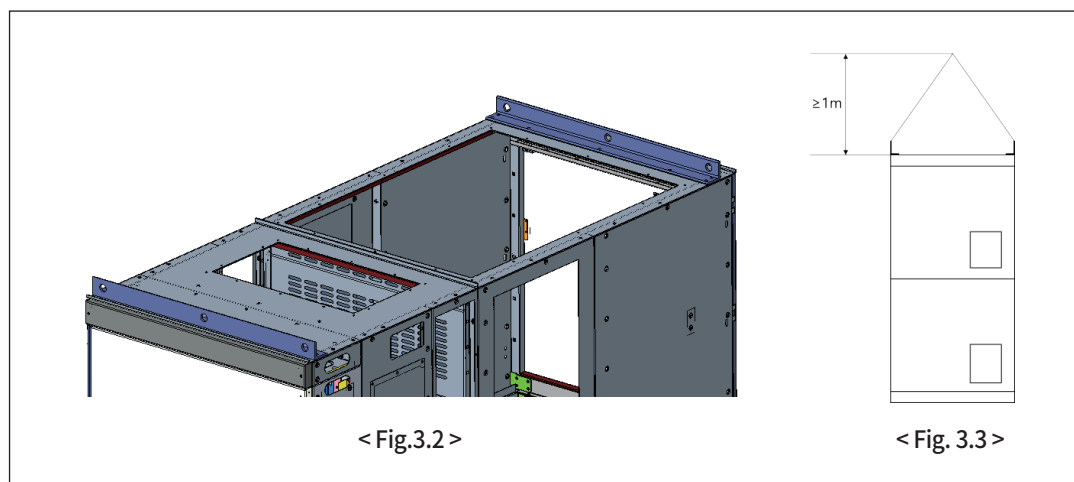

3.3 Storage

3.3.1 Storage method

If the equipment is to be stored for a lengthy period of time, it should be prepared for storage and stored under the following conditions.

DO NOT Uncrate wooden box of the switchgear.

Choose a clean dry location free from harmful vapors. Switchgear should be stored on a flat floor to prevent bending and structure twisting. Do not store directly on the dirt or mud. Some covering should be on the ground under the switchgear. Cover with heavy traps to keep dust and dirt from settling in. Allow adequate ventilation to remove condensation.

If dampness or condensation is encountered, heaters should be placed to prevent damage.

Remove any plastic, paper, cardboard, or fabric from the vicinity of the heaters. Never use heaters around flammable liquids or gasses.

If severe weather conditions are encountered, (e.g. heavy snow, rains, strong winds), switchgear should be stored inside the shelter of a building.

If the equipment must be stored for more than three months from the shipment date, it should be placed in a dry, clean, well-ventilated, and heated indoor environment. After 12 months from the shipment date, it is recommended to uncrate the equipment for a visual inspection under the manufacturer's supervision, and then repack it.

Batteries and breakers should be stored under the requirements of their respective instruction manual. In general, those requirements are more stringent than switchgear requirements.

3.3 Storage

3.3.2 Check point for storage







- Wooden condition
- Vacuum bag condition
- Humidity in vacuum bag
- SWGR condition

3.4 Storage guarantee

The quality guarantee for the panels lasts for 2 weeks after unpacking when stored indoors in a well-ventilated area. The storage area should have a well-drained, paved floor, and the temperature should be above 60°F with air humidity not exceeding 60%. After the guarantee period has expired, the manager must repack the panels.

WARNING

Do not walk on the roof of the panels (rupture point in pressure relief devices). The pressure relief devices could be damaged.

NO	DESCRIPTION	MARK	POSITION
1	THIS WAY UP		SIDE
2	FRAGILE		-
3	KEEP DRY		-
4	DO NOT USE HOOK DO NOT PUNCTURE		FRONT
5	SLING HERE		-
6	DO NOT TUMBLE DO NOT DROP		-
7	CENTER OF GRAVITY		-

INSTALLATION

4. INSTALLATION

4.1 Installation

For installation at site, the switch-room must be completely set up. There should also be lights, power supplies, locking devices, and ventilation systems should be available.

The electric room should be well-ventilated. Avoid high temperatures and humidity. It should be well-ventilated and avoid high temperature, and humid area. Even when humidity is relatively low condensation can occur if there is significant temperature change. An air conditioner or dehumidifier should be present at the site if this occurs.

It is recommended to install UL LV SWGR at a place where salt, explosives, or toxic gas are avoided. It should be installed in a place where there is no flooding and or water-drops occur. Especially, take a special care to not cause the accidents due to water leakage from the upper floor. Do not install combustible gas, water, or fuel pipes in the power substation.

Power cables and control cables which are to be connected to the switchgear should be prepared in advance. Where switchgear panels have top-mounted structures for earthing switches or instrument transformers, it must be ensured ensure that ceiling height is sufficient to open plates.

4.2 Foundations

Before placing the switchgear, the foundation must be settled. The mounting area of the switchgear should be within 0~2mm. Adjustments are made by using a steel plate or by installing steel plates under the corners and center of cubicles if needed.

Uneveled foundation may cause improper operation of doors. Weatherproof seals may not align correctly.

Breakers may not racking in and out. Section alignment and bus bar connections would be much more difficult. Uneveled areas in front of indoor sections may interfere with door opening, ACB operating in-out

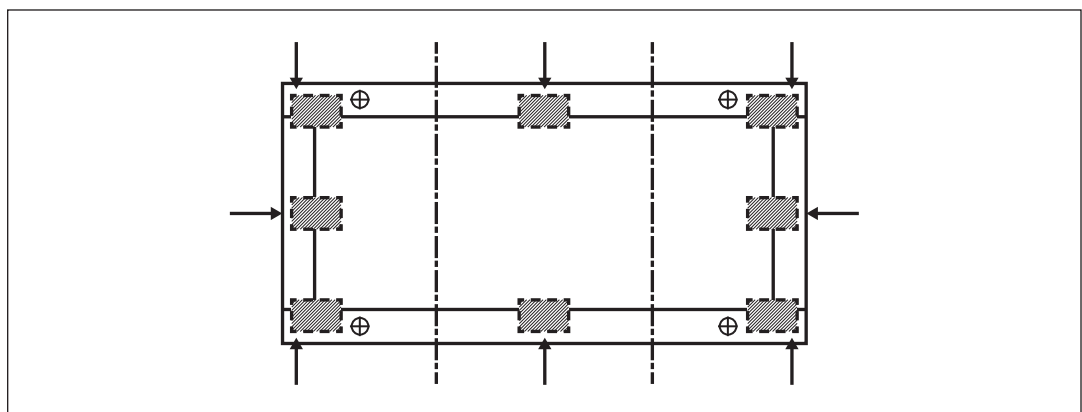

4. INSTALLATION

4.2 Foundations

For switchgear installation, it is recommended that there are no protuberances [i.e. conduits, wiring, ground connectors] above the level of the concrete. This will prevent problems when the switchgear is placed. All concrete preparation work should be done prior to placing any switchgear. This includes leveling, drilling holes and finishing.

In addition to the physical problems of doing concrete work after placing the switchgear, concrete work will generate dust which is harmful for switchgear.

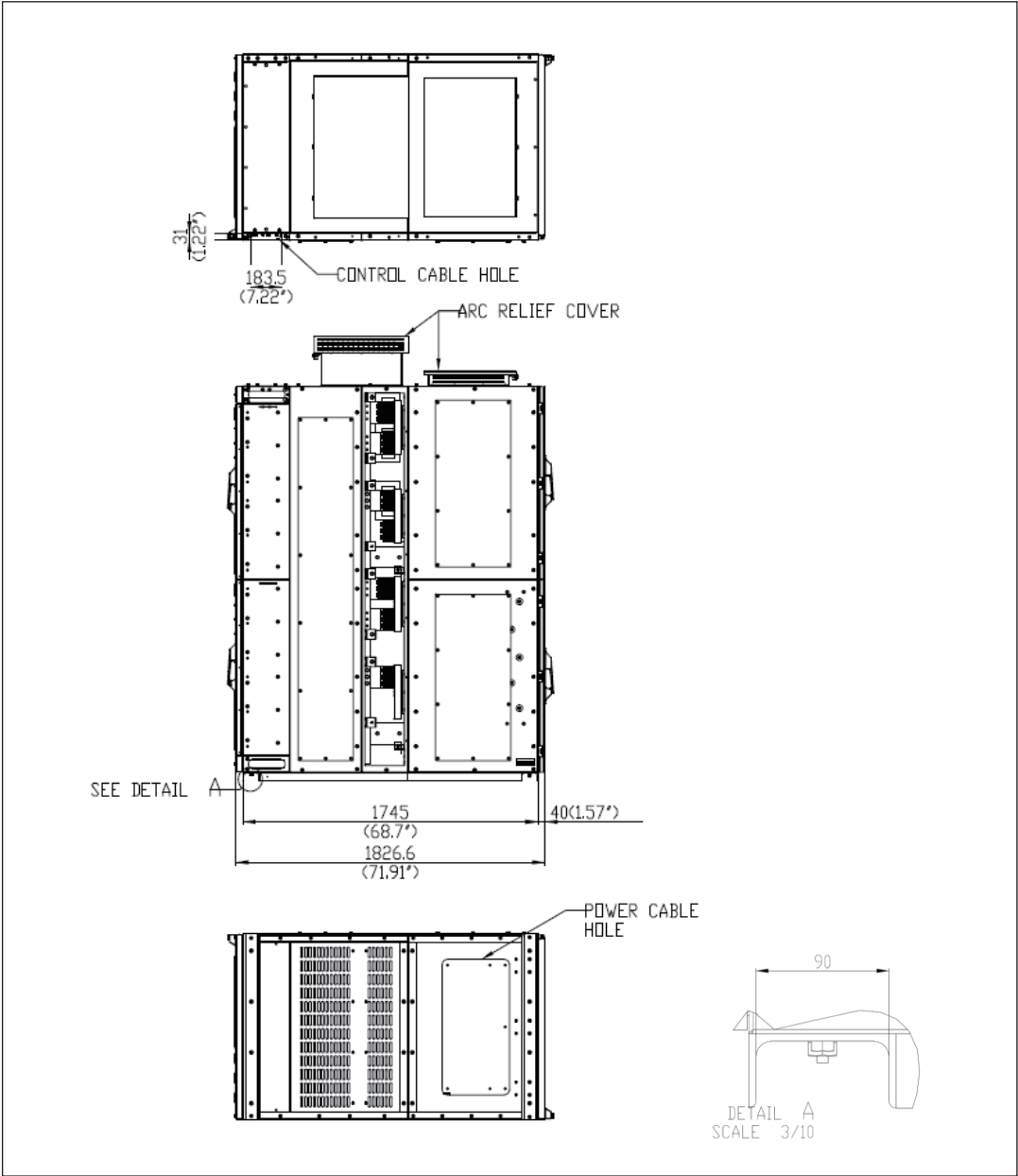

< Fig. 4.1 Foundation of Indoor Equipment >

INSTALLATION

4. INSTALLATION

4.3 Placement

Prior to placing switchgear on the foundation, all packing and crating material should be removed. If it exceeds 2 sections or more, the center section should be placed first. Switchgear sections should be placed before aisle section.

Align the first section of switchgear. It is important that the other sections will be exactly aligned in case the first section correctly placed. Install on each side from the center section. Each section should be aligned when placed.

After the Switchgear is placed; check the flatness and vertical level. When it is out of level, shims should be inserted at the point where the switchgear is fastened to the foundation.

Remove all temporary bracing and shipping supports. These items have been painted in different colors to aid in identification.

ACCESSING THE MAIN CIRCUIT COMPARTMENTS

5. ACCESSING THE MAIN CIRCUIT COMPARTMENTS

5.1 Accessing cable compartment

 **DANGER**

The cable compartment may only be opened if live busbar is energized

5.1.1 Removing cable compartment cover

- Cable compartment

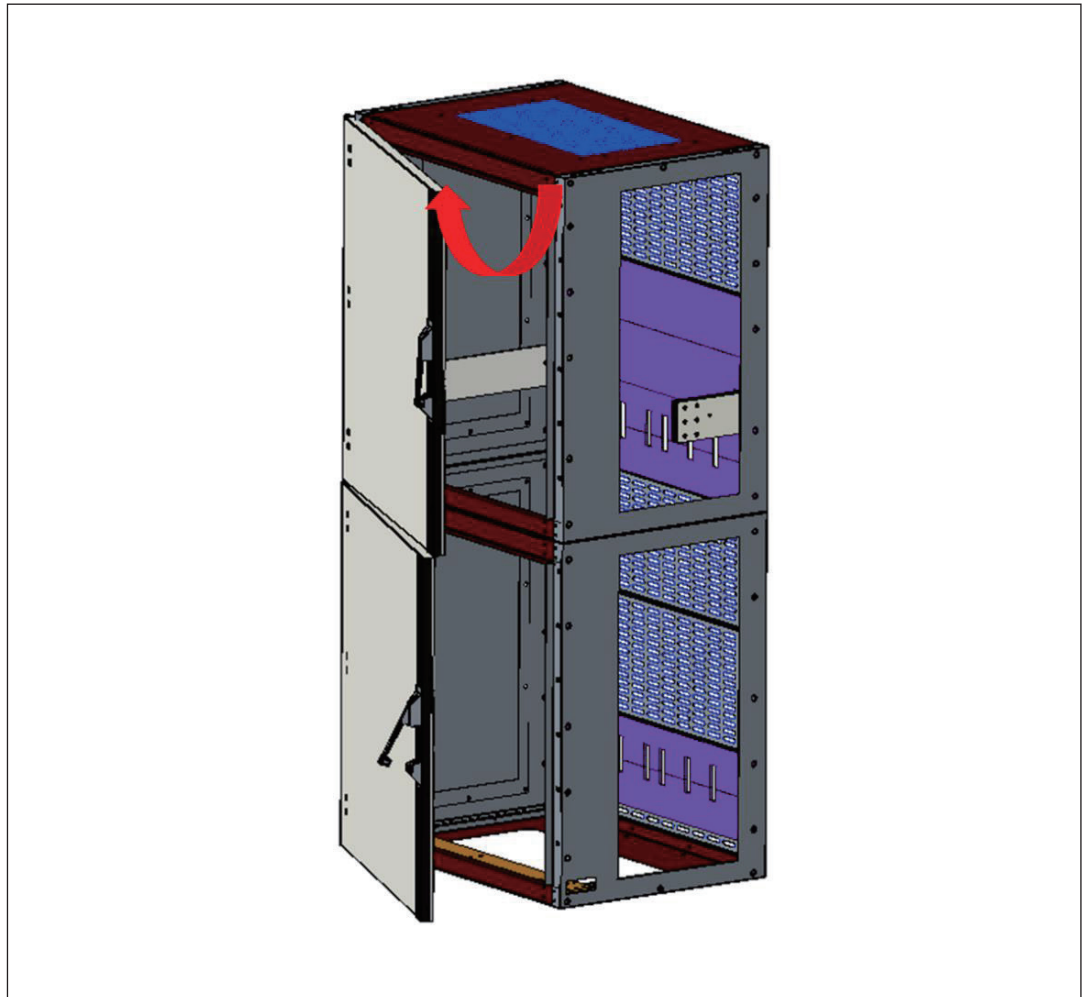

< Fig. 5.1 >

le compartment door (Refer to Fig. 5.1).

ACCESSING THE MAIN CIRCUIT COMPARTMENTS

5. ACCESSING THE MAIN CIRCUIT COMPARTMENTS

5.2 Accessing the ACB Compartment



DANGER

The switching device compartment may only be opened if the ACB position is in the disconnected position.

5.2.1 Opening and closing the cover of the ACB Compartment

● Opening the door

1. If the ACB is installed in the ACB compartment, then make sure that the ACB is in disconnected position
2. Insert the key and turn it clockwise to open the door (Refer to No.1,2 in Fig 5.2)
3. Unlock the door by using the key provided (Refer to Fig. 5.2 and 5.3). Lift the door handle which is marked in No.3. Pull the door handle.

● Closing the door

- Closing the door is performed in the reverse order of opening the door.

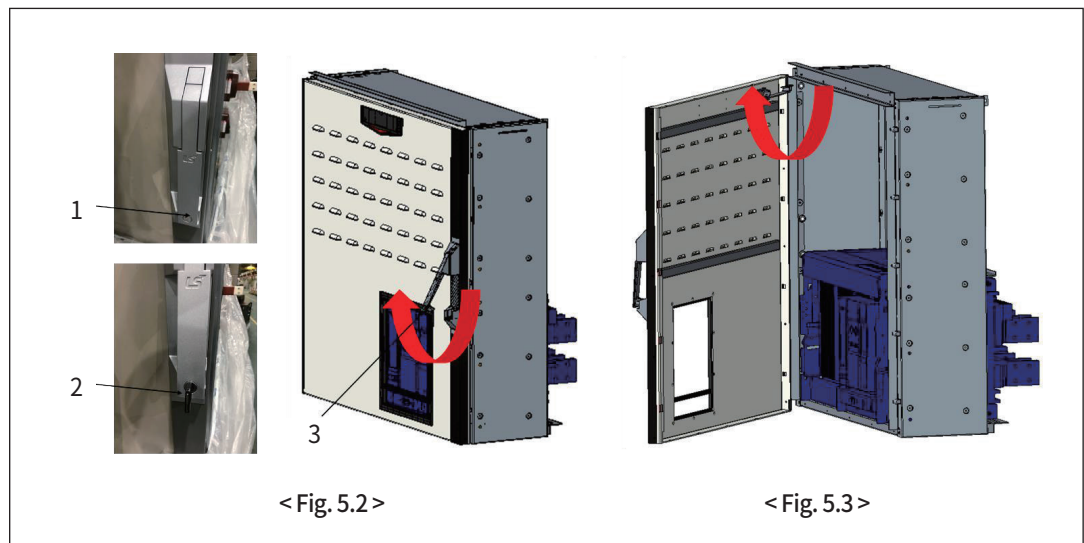

5. ACCESSING THE MAIN CIRCUIT COMPARTMENTS

5.3 Removing and Inserting ACB from the panel

5.3.1 Removing and Inserting ACB Using Hoist

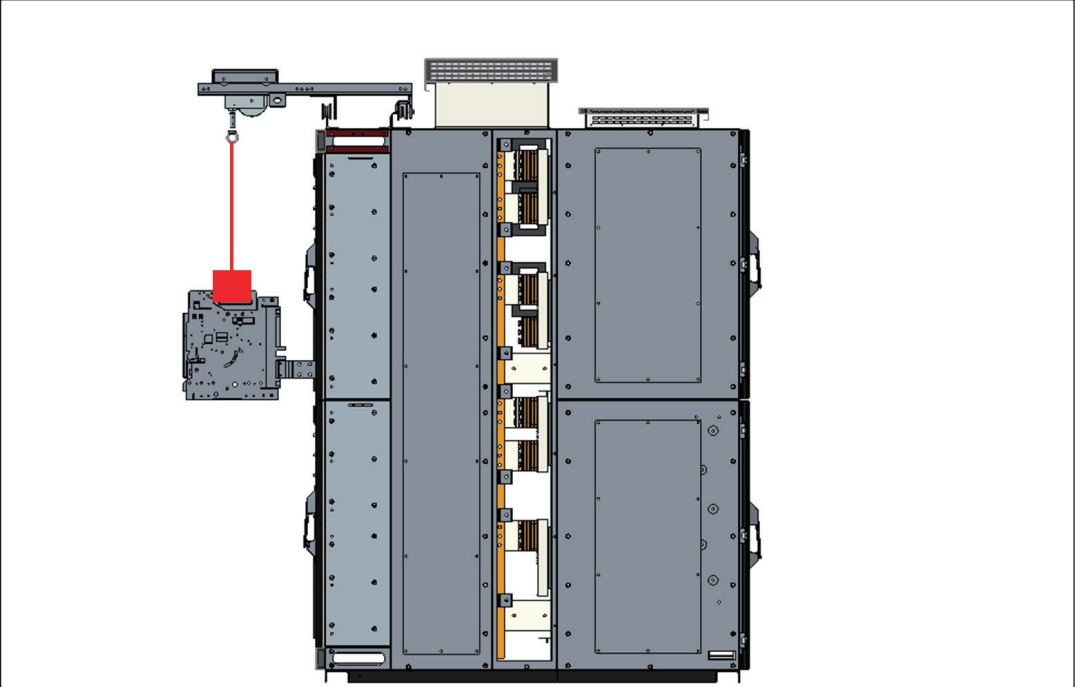

< Fig. 5.4 >

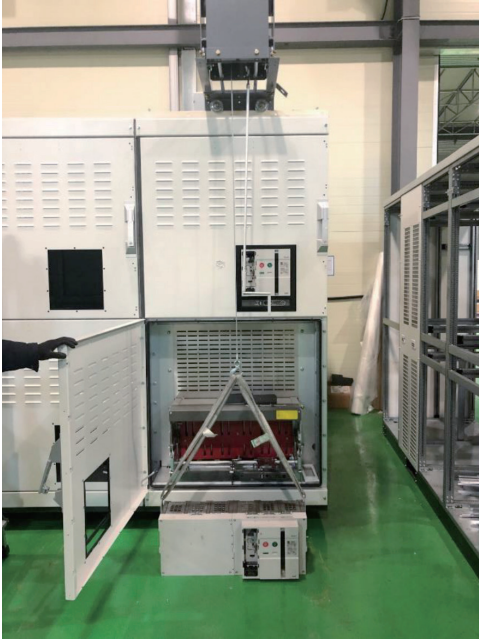

< Fig. 5.5 >

ACCESSING THE MAIN CIRCUIT COMPARTMENTS

5. ACCESSING THE MAIN CIRCUIT COMPARTMENTS

5.3

Removing and Inserting ACB from the panel

- **Removing the ACB from the panel.**

1. Check the ACB disconnect status and adjust the position of the ACB Hoist.
2. Move the ACB Hoist in front of the panel and hang the hoist hook on the ACB (refer to Fig.5.4).
3. Then put down ACB on the ground.

- **Inserting the ACB into panel.**

1. Hang the Hoist bracket on the both side of ACB cradle (refer to Fig. 5.5).
2. Operate the ACB hoist in front of the panel and lift ACB up to Panel.
3. Install the ACB into the panel, then check the handle and locking

5.3.1 Removing and Inserting ACB Using ACB Lifter

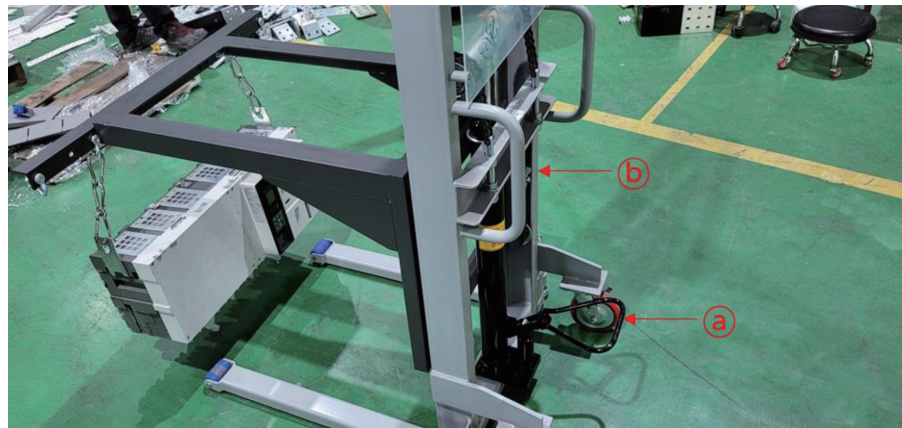

< Fig. 5.6 >



< Fig. 5.7 >

5. ACCESSING THE MAIN CIRCUIT COMPARTMENTS

5.3 Removing and Inserting ACB from the panel

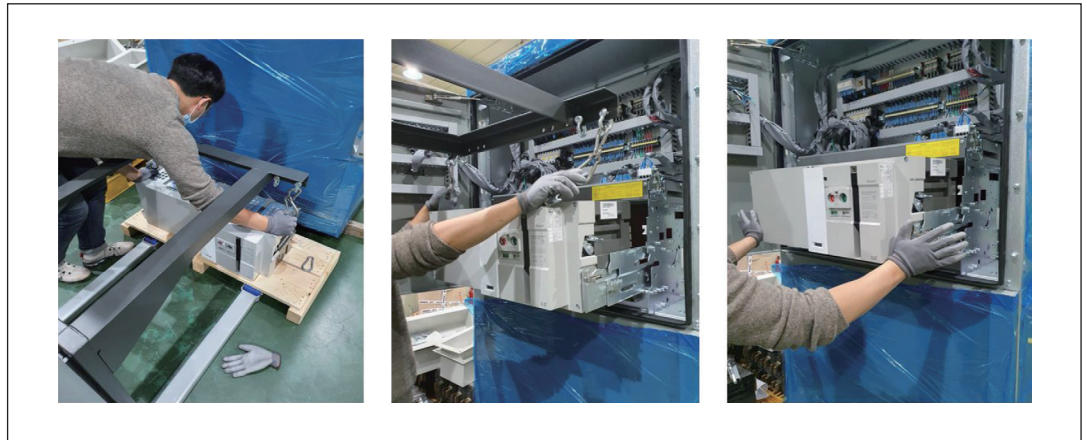

< Fig. 5.8 >

- **ACB Lifter manual.**

1. Pedal down and up on A to elevate the fork (Refer to Fig. 5.6).
2. Rotate B counter clockwise to descend the fork (Refer to Fig. 5.6).

- **Removing the ACB from the panel.**

1. Check the ACB disconnect status and adjust the position of the ACB Lifter.
2. Move the ACB Lifter in front of the panel and hang the lifter bracket on the both side of ACB (refer to Fig.5.7).
3. Then put down ACB on the ground.

- **Inserting the ACB into panel.**

1. Hang the ACB Lifter bracket on the both side of ACB (refer to Fig. 5.8).
2. Move the ACB Lifter in front of the panel and lift ACB up to Panel.
3. Install the ACB into the panel, then check the handle and locking

5.4 Accessing bus bar compartment



DANGER

Risk of fatalities due to high voltage. The bus bar compartment may only be opened if the bus bar is earthed



WARNING

The upper panels are not meant to be walked on. Persons may fall under, and get injured or may damage the panel. Do not step on any devices when working on the top of the panel is required.

ACCESSING THE MAIN CIRCUIT COMPARTMENTS

5. ACCESSING THE MAIN CIRCUIT COMPARTMENTS

5.4 Accessing bus bar compartment

5.4.1 Accessing busbar compartment through top cover

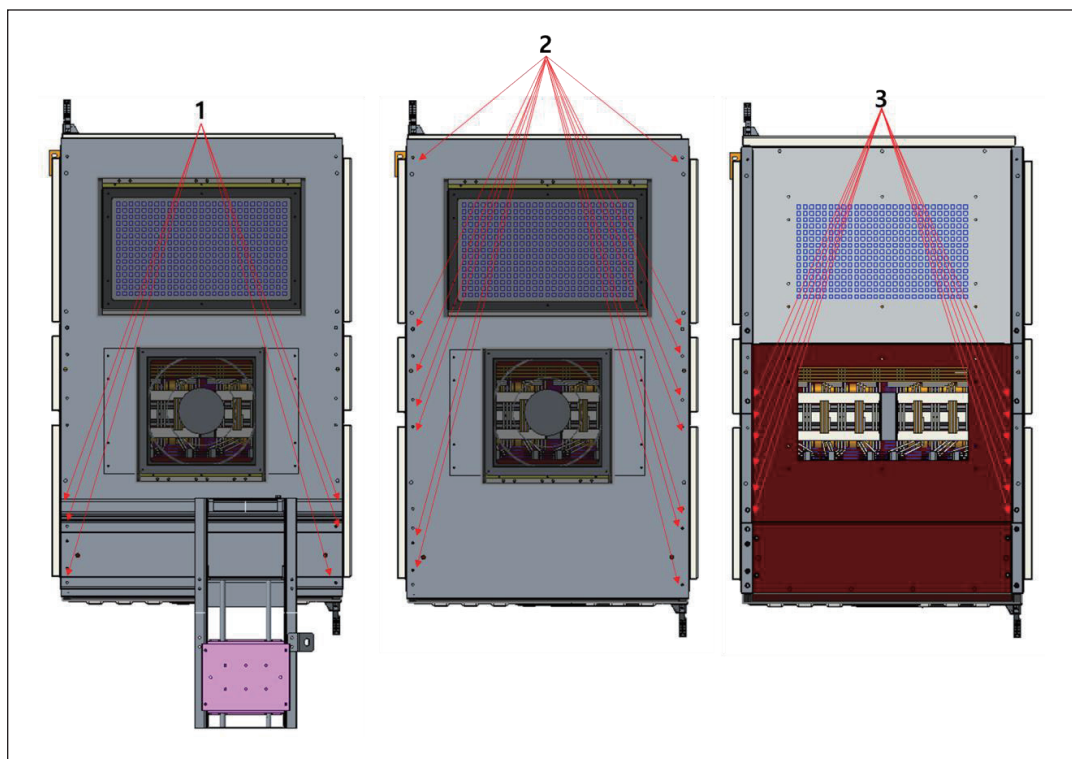

< Fig. 5.9 >

- Remove the hoist and top cover by following procedures for access of bus bar compartment through the top cover.

1. Remove the M8 bolt (6EA) which is marked in No.1 of Fig. 5.9, and then can detach the ACB hoist from the hoist rail.
2. Remove the M8 bolt (14EA) which is marked in No.2 of Fig. 5.9, and then can detach the top cover.
3. Finally, remove the M8 bolt (14EA) which is marked in No.4 of Fig. 5.9 then can detach the sheet metal of main bus compartment.

5. ACCESSING THE MAIN CIRCUIT COMPARTMENTS

5.4 Accessing bus bar compartment

5.4.2 Accessing busbar compartment through cable compartment

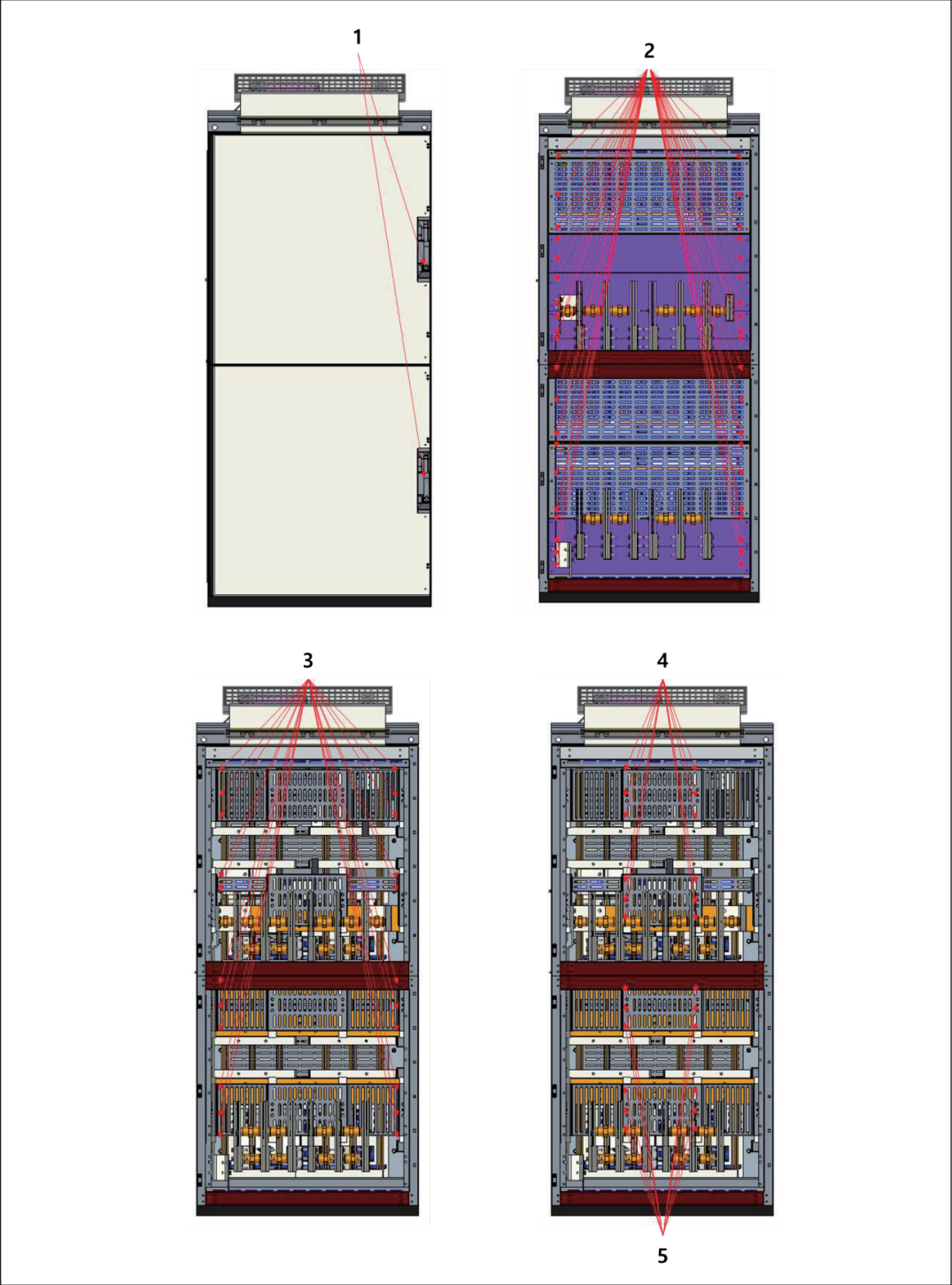

< Fig. 5.10 >

ACCESSING THE MAIN CIRCUIT COMPARTMENTS

5. ACCESSING THE MAIN CIRCUIT COMPARTMENTS

5.4 Accessing bus bar compartment

- **Remove the doors and barriers by following procedures for access of bus bar compartment through the cable compartment.**
 1. Unlock the door by using the key provided (Refer to Fig. 5.10). Lift the door handle which is marked in No.1. Pull the door handle.
 2. Remove the M6 bolt (42EA) which is marked in No.2 of Fig. 5.10.
 3. When electrical accessories such as cable, Current transformer (CT) and etc. are installed in the bus compartment, these accessories are removed and M8 bolt (22EA) No.3 of Fig. 5.10.
 4. Finally, remove the M8 bolt (22EA) which is marked in No.4 and 5 of Fig. 5.10 and then get rid of metal barriers.

6. ASSEMBLY OF THE SUSOL UL LV SWGR

6.1 Safety provisions

The switchgear panels may only be installed and assembled by the manufacturer's staff or by persons who are qualified.

6.2 Important instructions for assembly

The switchgear panels may only be installed and assembled by the manufacturer's staff or by persons who are qualified.

i IMPORTANT

- Condensation, dirt, and dust during assembly should be avoided on all accounts, in order to prevent damage on the panels.
- For assembly, observe the assembly drawings supplied with the equipment. Read them before you commence assembly work.
- For all screw connections, refer to the tightening torques specified in Table A on page 28~29.
- Assembly of switchgear-specific equipment (e.g. sidewalls, deflectors, pressure relief ducts, etc.) is described in the manual for Appendix A

6.3 Assembly

6.3.1 Indoor Assembly

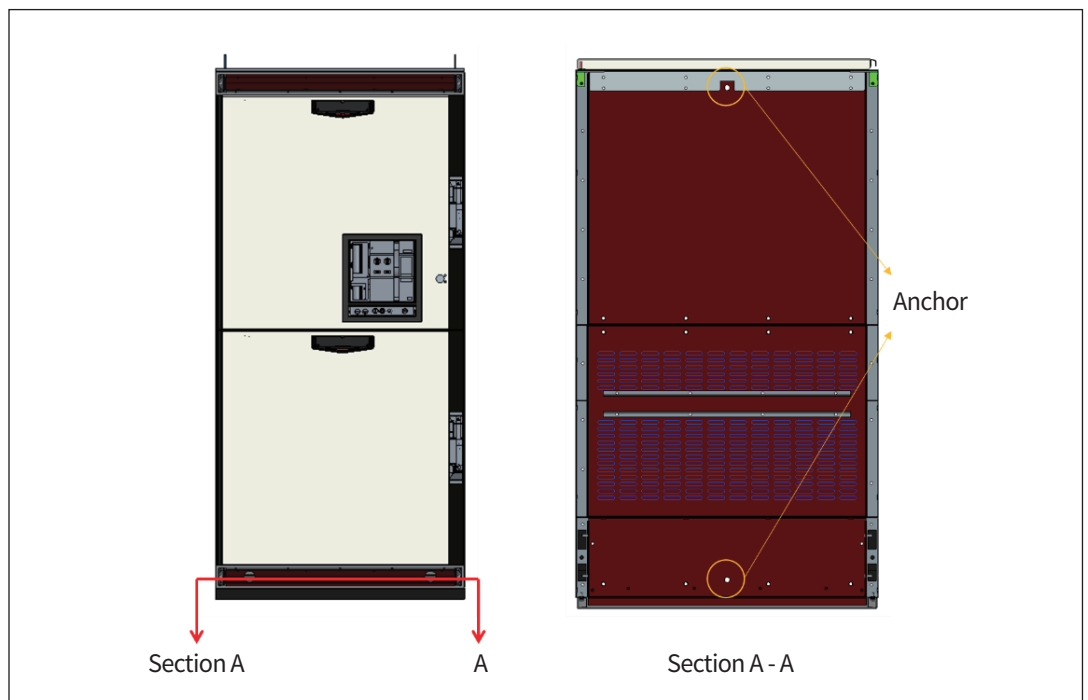

< Fig. 6.1 >

ASSEMBLY OF THE SUSOL UL LV SWGR

6. ASSEMBLY OF THE SUSOL UL LV SWGR

6.3 Assembly

After the switchgear has been aligned and leveled, it must be bolted together. Loosely attach each section to others. This will allow any last minute shimming to facilitate assembly. Tighten all bolts to firmly secure sections together. When assembly has been completed, anchor switchgear to foundation. Anchor locations are shown in Fig. 6.1.

6.3.2 Main BUS connection to other Sections

- Remove the Barriers between bus and cable compartment by following procedures for assembly of Main bus to other sections.

1. Remove the M5 bolt (40EA) which is marked in No.1 of Fig. 6. 2, and then can detach the section barriers between bus and cable compartments.
2. Remove the M8 bolt (26EA) which is marked in No.2 of Fig. 6.2, and then can detach the section barriers between bus and cable compartments.
3. Approach the yellow circle in Figure 6.2 and connect the busbar by tightening bolts as shown in Figure 6.3.
4. The bolt can be inserted from the front to the rear, and use the length of the bolt is M12×70mm.

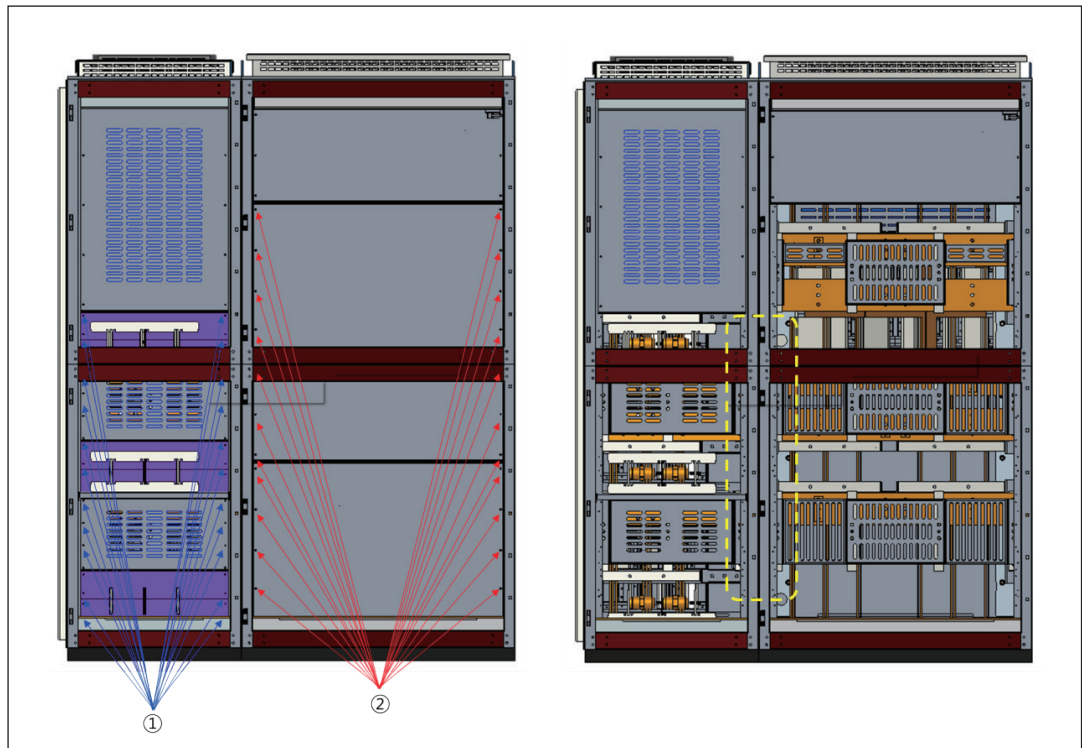

< Fig. 6.2 >

6. ASSEMBLY OF THE SUSOL UL LV SWGR

6.3 Assembly

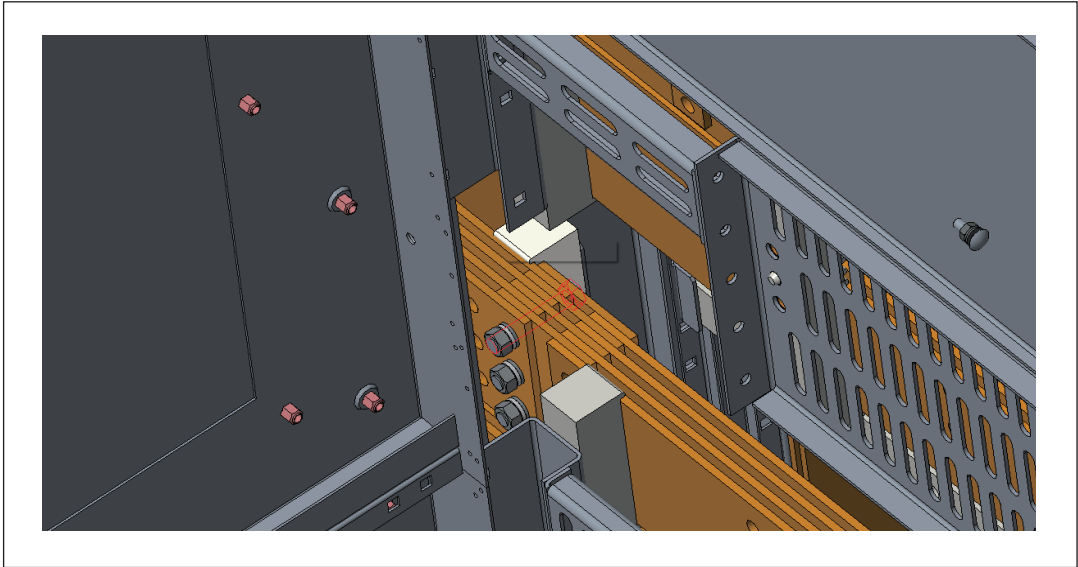

< Fig. 6.3 >

Main bus connections are made between sections by bolting each main bus. When the bus is aligned with allowing bus bars in adjacent cubicles, they are jointed directly to each other by using bolts.

When this is not possible, links are provided for bus connections.

Clean contact surface with nonflammable, non-harmful cleaning solution, and wipe off with nonabrasive cloth. Bolt bus sections together. Attach the boots if provided.

※ All bolted bus should be made up using the proper torque value as shown in table A.

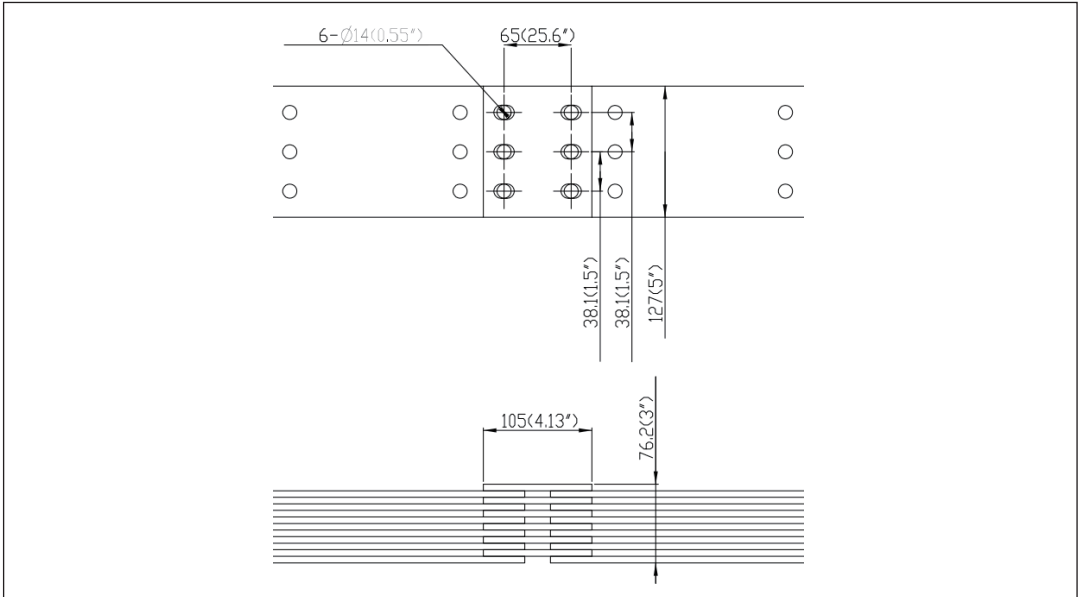

[Main Bus Connection]

ASSEMBLY OF THE SUSOL UL LV SWGR

6. ASSEMBLY OF THE SUSOL UL LV SWGR

6.3 Assembly

Table A. Torque values for switchgear hardware

Category	Torque(kg · f · cm)
Bolted bus connections	M6 : 70~100 M8 : 200~245 M10 : 350~490 M12 : 600~850
Power cube connections	M6 : 70~100 M8 : 200~245 M10 : 350~490 M12 : 600~850 M16 : 1500~2040
Insulators	M8 : 160~200 M10 : 300~360 M12 : 400~460
Bushings	M10 : 300~360 M12 : 400~460
CT case (Plastic)	M8 : 100~120
CT 2'nd terminal	M5 : 30~40

Train the cables in the proper path to the terminals, using temporary clamping device if required, and cut to the proper length. Strip the insulation to the desired dimension, being careful not to damage any strands.

Both the cable terminals connect to the ends of the bars in the rear compartment. A non-oxidizing lubricant can be used at these connection surfaces.

Clamp the cable permanently to the cable supports.



CAUTION

- If there are some parts to block the function during assembly, release the blocking after assembly.
- Make a final inspection to check that there are no tools, construction materials, or other foreign matter left in the switchgear.

6.3.3 Control Wiring Interconnection

This switchgear has been designed to facilitate interconnection. The side of each shipping section wall is interconnected with terminal blocks. Pre-labeled wires are coiled at one set of blocks to run on the other side of the shipping split. Refer to wiring and schematic drawings for particulars on actual wiring.

6. ASSEMBLY OF THE SUSOL UL LV SWGR

6.3 Assembly

6.3.4 Ground bus

Ground bus is installed at the bottom of the switchgear in each section. Jumpers are provided to connect each sections of ground bus together. All grounds in the switchgear will be tied completely together. When the ground cable connects to a ground terminal, the mounting bolt is torque standard in “Table A” for the extent of bolt fastening.

6.3.5 Current Transformers

Current transformer's secondary circuit must be shorted. After the installation, the shorted secondary circuit should be removed.

※ Note!

If spare current transformers are in the system with no loads, leave shorted to avoid developing high voltage across secondary terminals. Never leave when the secondary of current transformers is opened.

6.3.6 Fuse

Power fuses used as isolating devices, voltage transformer protection, or high side control power transformer protection are taped in place prior to shipment. Remove the tape and lift fuses to make sure they are removable.

6.3.7 Key Interlocks (If provided)

Key interlocks are used as a safety system in some switchgear. During assembly extra keys may be available to facilitate the installation. It is the responsibility of the customer to control and distribute keys. After installation, all keys should be collected and kept securely. Extra keys should be safely stored or destroyed to prevent accidents.

6.3.8 Primary Cables Connection

In case of connecting primary cables to terminal or bus bar, the followings should be observed;

- Before connecting the incoming cable, open the primary circuit breaker first.
- Remove the cover plate for incoming cable, and then pull the incoming cable all the way up to the bus terminal of the circuit breaker.
- Considering diameter and number of the incoming cable, make a hole for cable entrance. In case of using cable gland, perforate a penetrated hole based on outer diameter of the gland.
- Within the panel, the length of the incoming cable shall be adjusted in consideration of the extent of wire bending radius. In case of bending the incoming cable vertically at the lower part of the panel, pay attention not to destroy insulation of the cable.
- Penetrate the incoming cable through the perforated cover plate and fix it.
- At the connection of the cable to the terminal, refer to the mounting bolt torque standard in “Table A” for the extent of bolt fastening.
- When connecting the power cable, it is recommended to treat the ending part with termination kit (RAYCHEM, 3M or equivalent). Refer to the following figure for the distance of the ending part;

ASSEMBLY OF THE SUSOL UL LV SWGR

6. ASSEMBLY OF THE SUSOL UL LV SWGR

6.3 Assembly

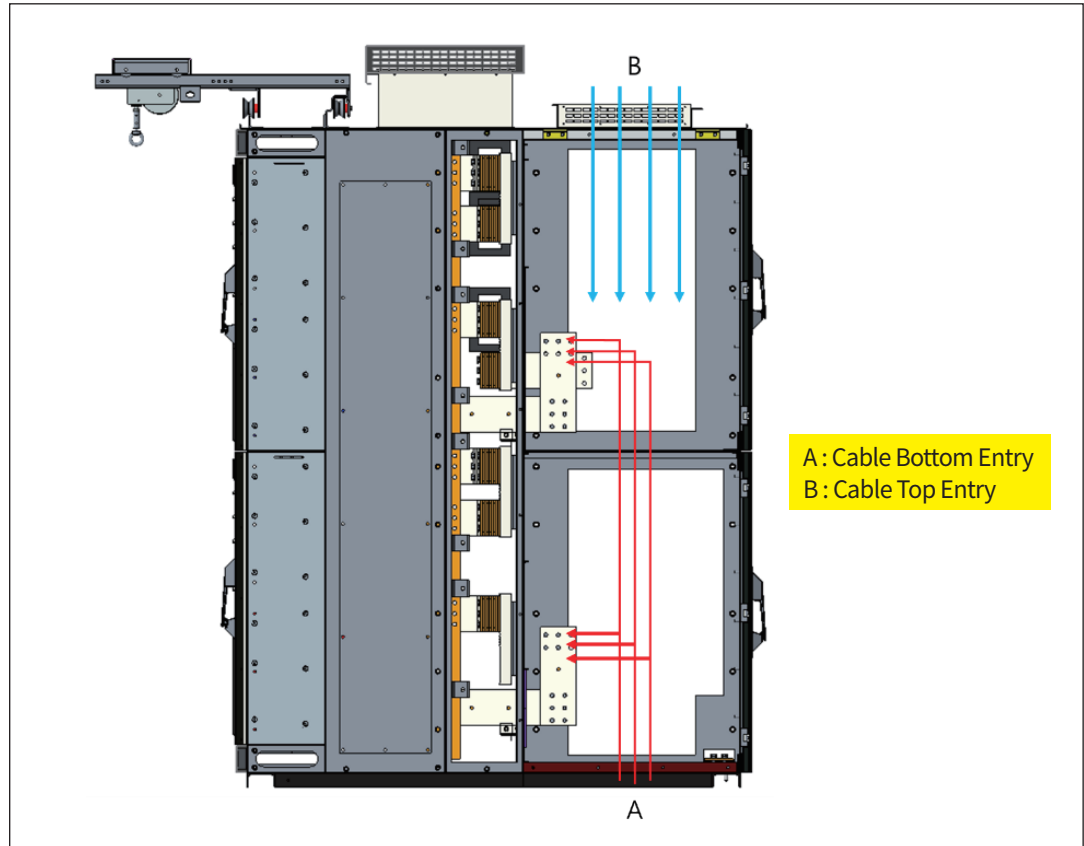

< Fig. 6.4 >

6.3.9 Bus Duct Connections

Bus duct connections to the switchgear are brought directly into cubicles. The connection point of the duct is either directly attached to the switchgear, or attached through an expansion joint. The bus itself is joined to the switchgear through a flexible connector.

6.3.10 Connection of Control Cable

Terminal block for control cable pulled from outside should use 15A or 30A to compensate decrease of line voltage since its cross-sectional area is greater than that of the control cable in the switchgear.

At the connection of incoming cable, perform wiring work referring to related drawings (Circuit diagram or wiring diagram).

6.3.11 Cleaning

The switchgear should be thoroughly cleaned to prevent problems later on. All garbage, paper, loose parts, etc. should be removed from the switchgear. It is recommended that the gear is vacuumed out to remove dust and dirt. Wipe down main bus insulation with clean rags.

Do not use paint thinner, lacquer thinner or aromatic solvents such as Benzene, Xylene, Trichlor, Triclene, MEK, MIBK, Toluol Benzol, Acetone, or Carbon Tetrachloride, as these will interfere with the insulation.

Acceptable cleaning fluids include Freon TF, denatured alcohol, Isopropyl or VM & P Naphtha.

6. ASSEMBLY OF THE SUSOL UL LV SWGR

6.3 Assembly

6.3.12 Pre-operational Testing and Inspections

During factory testing the switchgear underwent complete functional testing of the control and metering circuits, megger, and high potential testing of the main bus and an inspection to assure it was correct and complete. When the equipment is assembled in the field, it is important to conduct tests to assure that the switchgear has been correctly reassembled.

6.3.13 Connection of Control Cable

It is recommended to measure the primary bus with a megger test before energizing. A minimum of 100 megohms should be measured to ground and phase to phase. It may be necessary to disconnect voltage transformer fuses as voltage transformers are usually tried together in a delta or wye.

High potential testing is not required but if desired it should be followed according to IEEE standards. Potential and control power transformers must be disconnected during this test. Circuit breakers should be measured megger test prior to energization. Phase to phase and phase to ground insulation resistance must be at least 200 megohms.

6.4 Requirements regarding the switchgear room

Before installing the switchgear panels, make sure that the switchgear room is checked according to the switchgear documentation (Fig. 6.5 and 6.6).

- Observe the minimum distance between the switchgear and the wall of the building.
- The load-bearing capacity of the fastening areas must correspond to the weight of the switchgear (perform a stress analysis of the building).
- Check base frame (if used) for dimensions and positional tolerances.
- Check position of floor openings for high-voltage and low-voltage cables.
Before the switchgear is positioned at its site of installation, check that the fastening points are leveled. Unevenness must not exceed ± 2 mm/meter and 6 mm difference in height over the entire switchgear width.

ASSEMBLY OF THE SUSOL UL LV SWGR

6. ASSEMBLY OF THE SUSOL UL LV SWGR

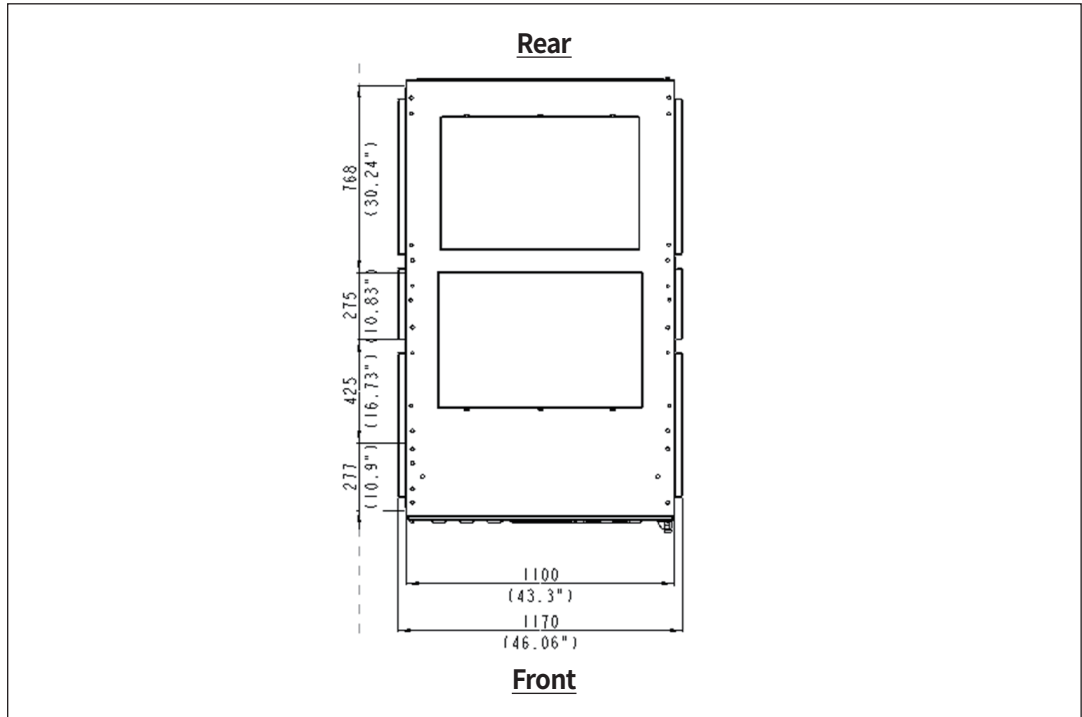

< Fig. 6.5 >

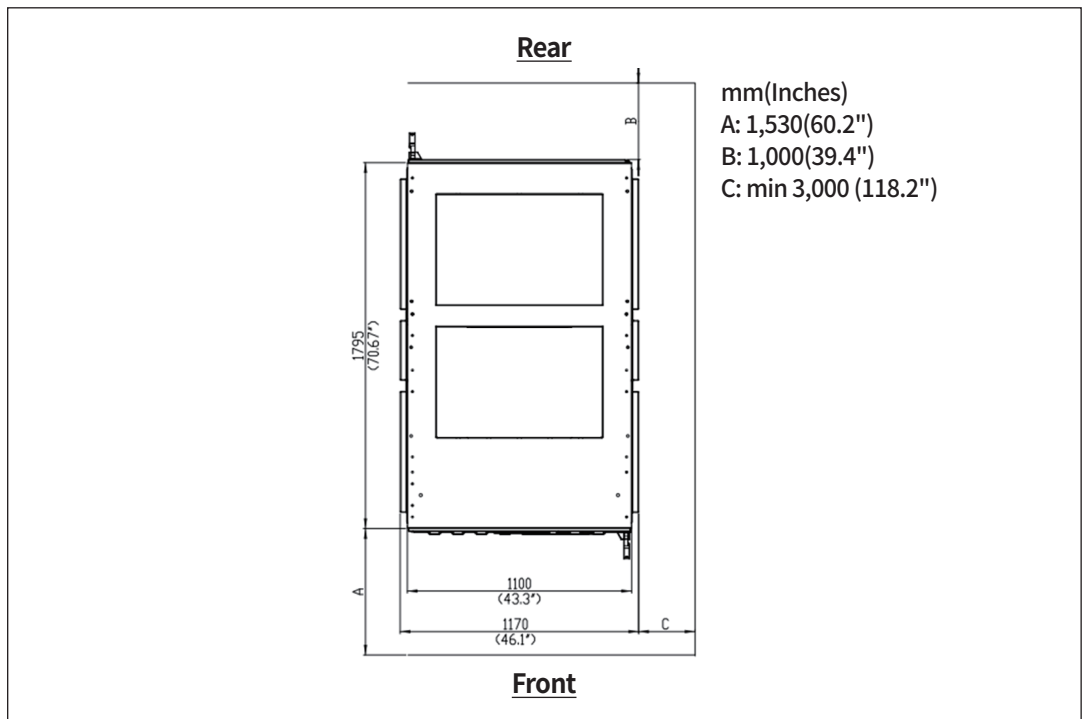

< Fig. 6.6 >

6. ASSEMBLY OF THE SUSOL UL LV SWGR

6.5 Fastening screws for connecting with other panels

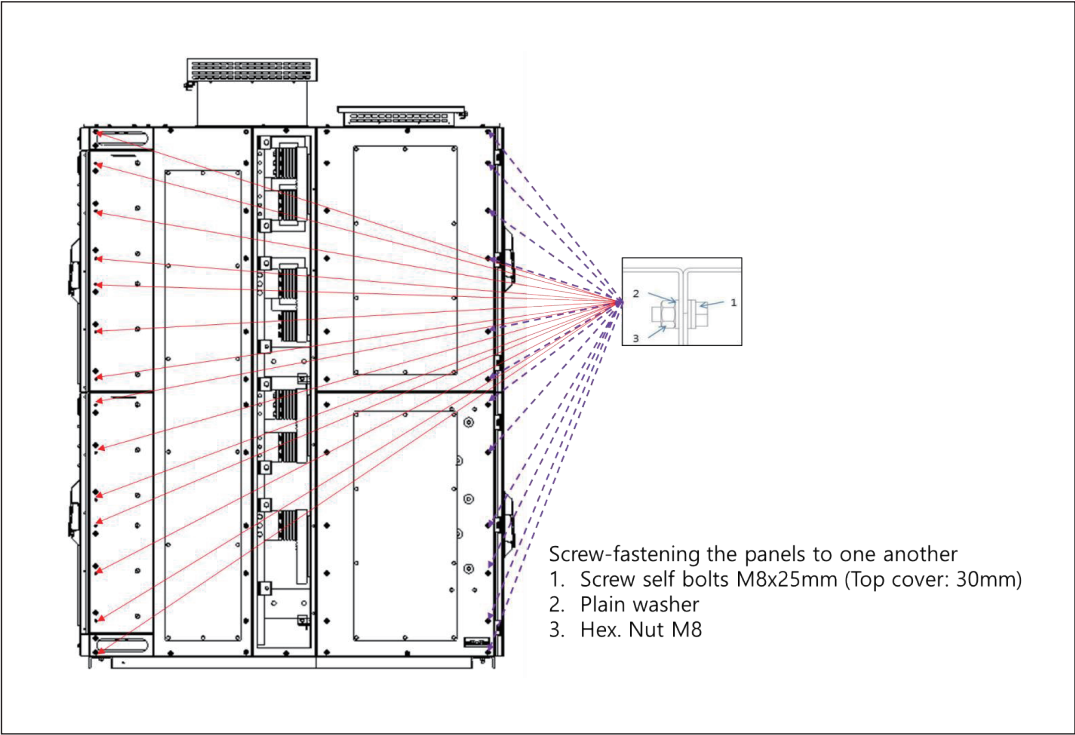

6.6 Top cover assembly

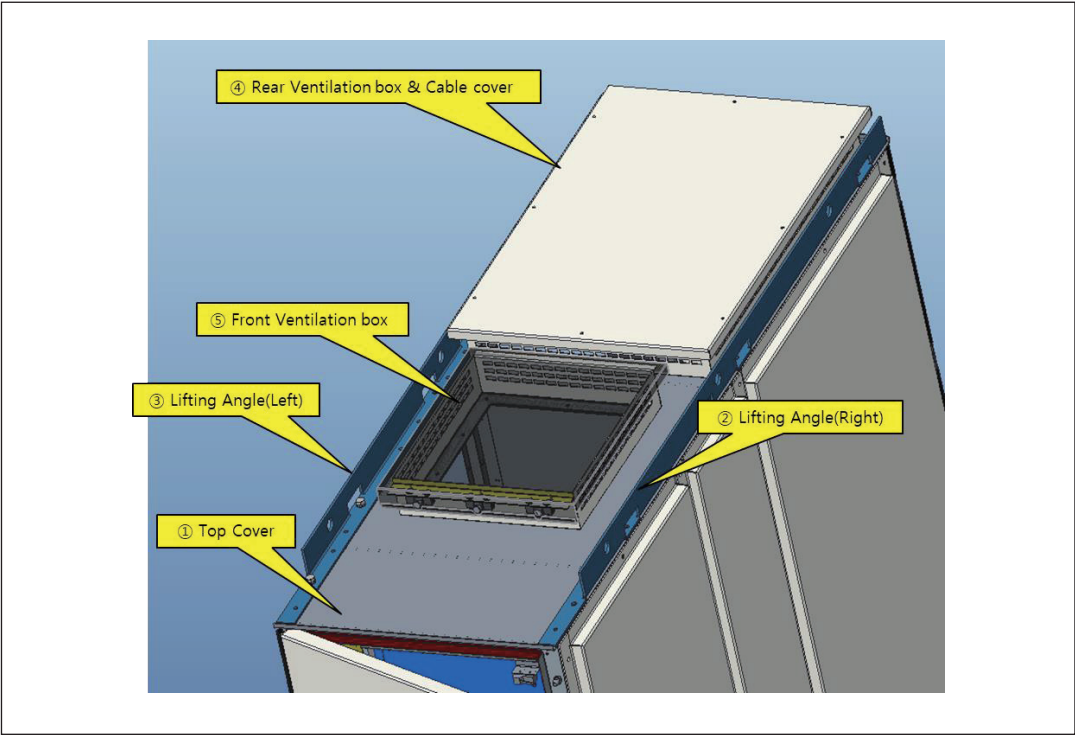

<Fig. 6.7>

ASSEMBLY OF THE SUSOL UL LV SWGR

6. ASSEMBLY OF THE SUSOL UL LV SWGR

6.6 Top cover assembly

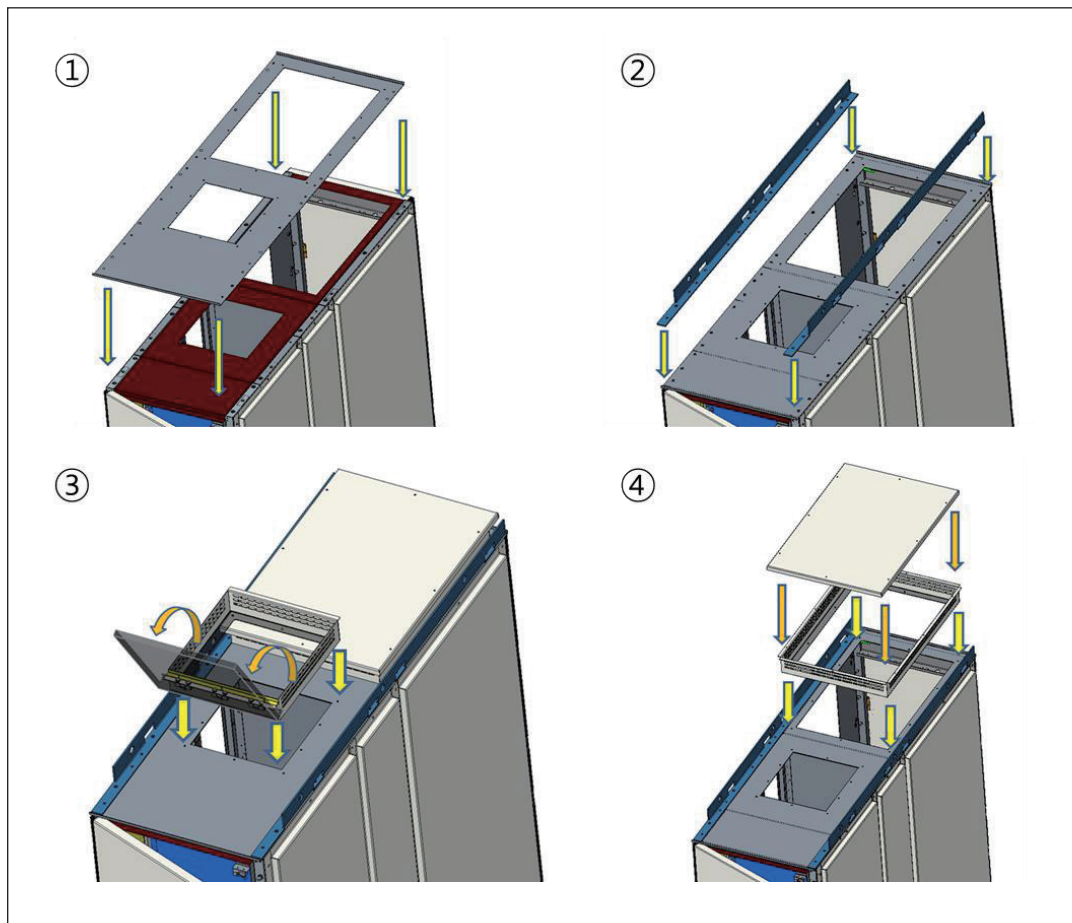

< Fig. 6.8 >

● **Combine the Top cover, lift angle and ventilation box to the LV switchgear by following procedures for assembly of Top cover (Refer to Fig. 6.7).**

1. RTighten the M8 bolts which is marked in No.1 of Fig. 6.8
2. Tighten the M8, M12 bolts which is marked in No.2 of Fig. 6.8
3. Open the cover of ventilation box and tighten the M5 bolts aligning the hole of top cover as shown in No.3 of Fig. 6.8.
4. Tighten the M5 bolts aligning the hole of top cover and the cover of ventilation box is assembled by tightening the M5 bolts as shown in No. 4 of Fig. 6.8.

6. ASSEMBLY OF THE SUSOL UL LV SWGR

6.7 Busbar assembly

Number of main busbars per phase	Diameter [mm]	Busbar arrangement
2 Busbar (2000A)	101.6×6.35	
3 Busbar (2500A)	101.6×6.35	
3 Busbar (3200A)	127×6.35	
4 Busbar (4000A)	127×6.35	
6 Busbar (5000A)	127×6.35	
6 Busbar (6000A)	152×6.35	

Comply with the specifications on treatment of contact surfaces and the tightening torques for bus bar screw fastenings in the Table A.

Clean all contact on the bus bar and outgoing feeder bus bars in the switchgear panels.
Observe location of bus bars and outgoing feeder bars.

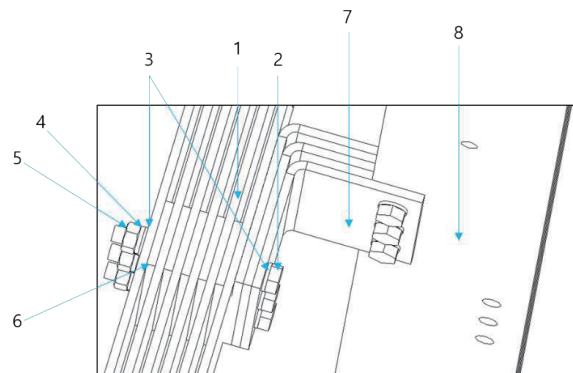

Busbar Assembly

1. Main busbar 6.35 × 101.6 (2ea/2000A, 3ea/2500A)
6.35 × 127 (3ea/3200A, 4ea/4000A, 6ea/5000A)
6.35 × 152.4 (6ea/6000A)
2. Screw M12
3. Plain washer
4. Spring washer
5. Nut M12
6. Busbar liner
7. Outgoing (Vertical) busbar 3200A : 3 × 6.35 × 127
4000A : 3 × 6.35 × 127
4000A : 4 × 6.35 × 127
5000A : 6 × 6.35 × 127
6000A : 6 × 6.35 × 152.4

ASSEMBLY OF THE SUSOL UL LV SWGR

6. ASSEMBLY OF THE SUSOL UL LV SWGR

6.8 Mounting the earth bus

Connection N-phase to Earth busbar

- Connect the earth bus (item 4) to the earthing system of the switchgear. (using M10)

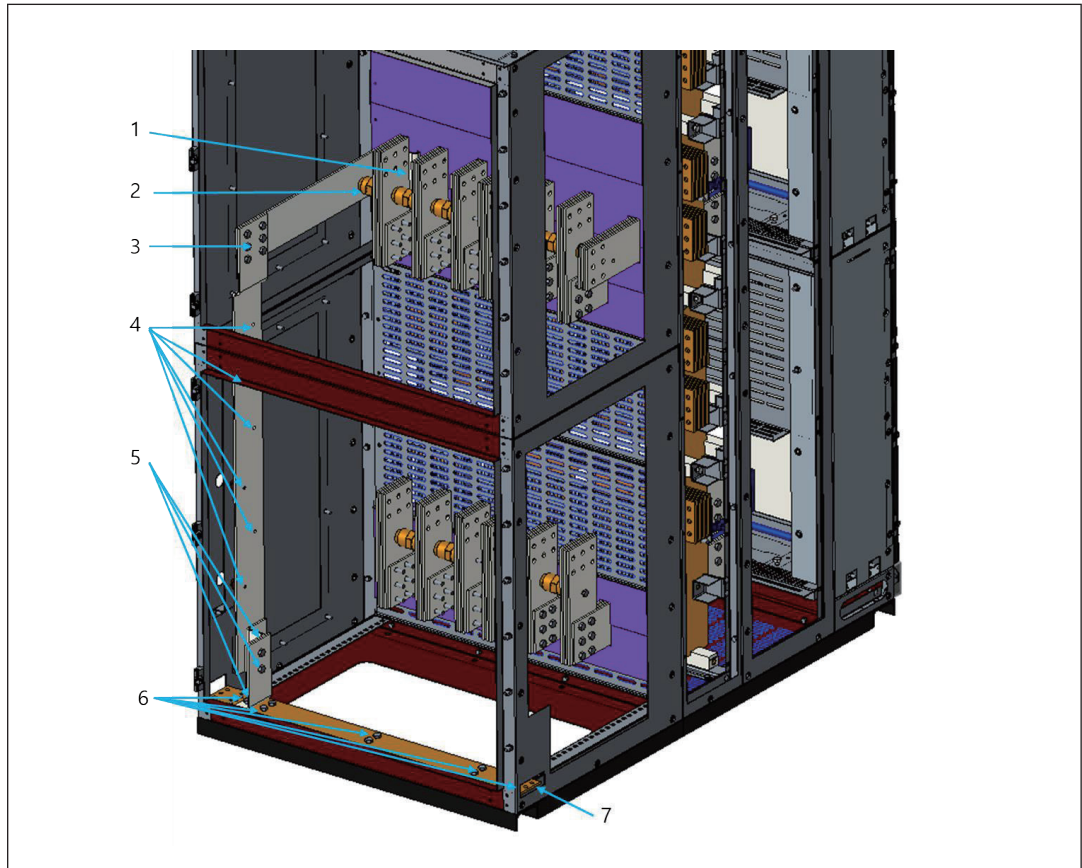

< Fig. 6.9 >

Mounting the earth bus

1. N-phase bus (Screw fastening M12 with spring washer, plain washer)
2. Connecting busbar to T-phase by phase supporter (Screw fastening M10 with spring washer, plain washer)
3. Connecting busbar to N-phase bus (Screw fastening M12 with spring washer, plain washer)
4. Epoxy supporter for panel attachment (Screw fastening M8 with spring washer, plain washer)
5. Connecting busbar to N-phase bus (Screw fastening M8 ,M12 with spring washer, plain washer)
6. Metal bracket for panel attachment (Screw fastening M8 ,M12 with spring washer, plain washer)
7. Connecting busbar to another panel (Screw fastening M10 with spring washer, plain washer)

7. OPERATION

※ Note on safety at work!

The relative work and operating procedures must be carried out carefully by trained specialists familiar with the installation, taking into account all the relative safety regulations according to the ANSI and other relevant professional bodies, as well as any local and work regulations and instructions.



WARNING

Do not walk on the top of the switchgear panels (Rupture points for pressure relief).
The Pressure relief devices could be damaged.

7.1 Commissioning

7.1.1 Preparatory work

In preparation for commissioning, the following work must be carried out prior to connection with the high voltage power supply:

- Check the general condition of the switchgear for any damage from defects.
- Visually inspect the switching devices, withdrawable parts, isolating contacts, insulating parts, and, etc.
- Check connection of the main earthing bar to install earthing conductor (follow the appropriate safety regulations).
- Check the paintwork for damage, and touch up if necessary.
- Remove all residue materials, foreign bodies, and tools from the switchgear.
- Clean the switchgear, rub down insulating parts with a soft, dry, clean, and non-fraying cloth. Remove any greasy or sticky dirt.
- Correctly remount all covers, etc. removed during assembly and testing procedures.
- Lifting eyebolts on high current air circuit-breakers must be removed if still fitted.
- Perform AC voltage testing of the main circuits according to ANSI Std. if necessary.
Pay special attention to voltage transformers and cables, etc. during this procedure.
- Switch the auxiliary and control voltage on.
- Carry out testing operations on switching devices manually or by electrical control while simultaneously observing the relative position indicators.
- Check mechanical and electrical interlocks for effectiveness, without using force.
- Set the protective devices in the switchgear to the required values and check their function with test equipment.
- Instruct local operators regarding the basic details of regular handling of the switchgear.
- Check readiness for operation and switching status of electrical systems upstream and downstream of the switchgear.

7. OPERATION

7.1 Commissioning

Depending on allocation of responsibilities, it may also be necessary to check the following equipment in area adjacent to the switchgear;

- Power cables
- Auxiliary cables
- Auxiliary power source
- Remote control system
- Switchgear room equipment
- Switchgear room conditions

7.1.2 Start-up

- Comply with all relevant safety regulations.
- Ensure that the circuit-breakers in the system are in OFF position.
- Remove any existing earthing and short circuit connections in the critical switching area.
- Energize the feeder cables.
- Connect the switchgear step by step, observing the signals and indicators.
- Check that relative conductors are in phase, where necessary, when there are several incoming feeder cables and switchgear section.
- Carry out all measurements and check all functions which depend on high voltage power supply being connected
- Watch out for any irregularities.



7. OPERATION

7.2 Switching Operation

※ Carry out switching operation with front doors closed!

7.2.1 Installation of switching operation

In order to make an operation of racking-in/out, insert bottom of the withdrawal assembly (Figure 7.1) into the hole completely which is installed at the bottom plate of CB compartment.

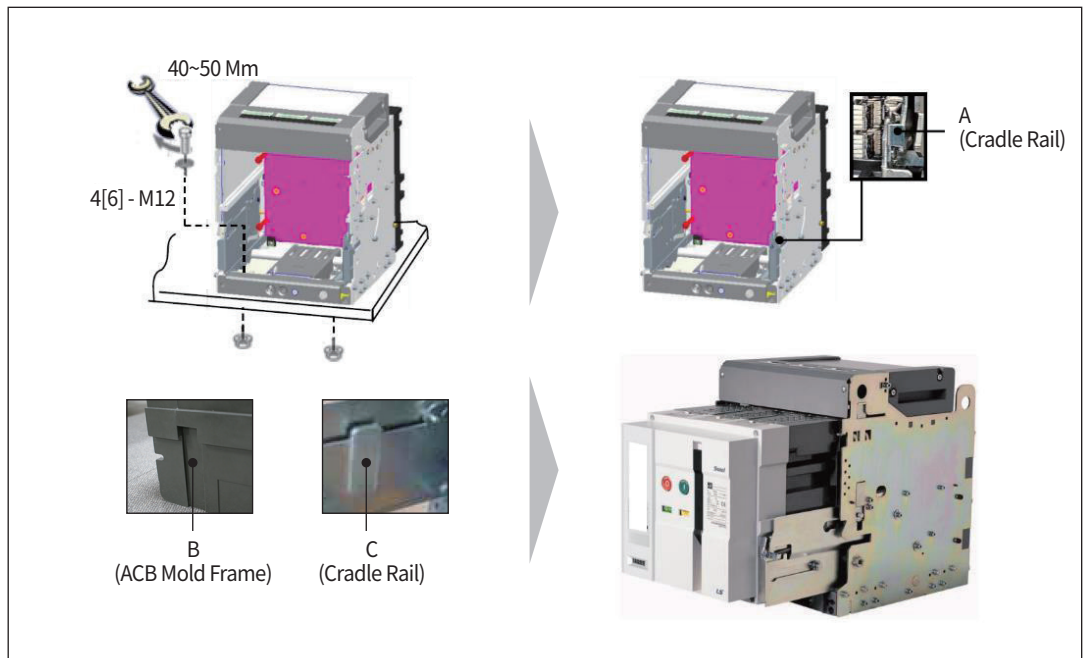

< Fig. 7.1 >

Installation of switching operation

- 1) Securely install the cradle at the bottom with M12 bolts (4EA)
- 2) Pull the extension rails of cradle forward.
- 3) Put the breaker on the rail as shown in picture by using lifting device.
- 4) Please check if the circuit breaker fits well to the cradle.
- 5) Slowly push the circuit breaker by moving the rail handle.

OPERATION

7. OPERATION

7.2 Switching Operation



7.2.2 Draw-in operation (CONNECT position → TEST position → DISCONNECT position)



1. Pull the extension rails of cradle forward

2. Put the breaker on the rail by using lifting device. Please check if the circuit breaker fits well to the cradle

3. Slowly push the circuit breaker by moving rail handle until it stops.



CAUTION

1. Operating handle of cradle only can be inserted when pushing OFF button.
2. If locking device for draw in / out protrudes, stop handle operation and move to next procedure as it indicates the complete operation of ongoing process.

4. Keep pushing the OFF button when the circuit breaker in a trip condition, and insert a handle to the body of the circuit breaker.

5. Check the draw-out handle properly inserted and then push the lock plate and turn the draw-out handle clockwise in order to insert the breaker.

6. When the breaker reaches the TEST position, the lock plate automatically projects and draw-out handle is locked.

7. Push in the lock plate and turn the draw-out handle again clockwise until the lock plate projects, the inserting operation is finished. At this time, the draw-out position indicator shows CONNECTED position.

7. OPERATION

7.2 Switching Operation

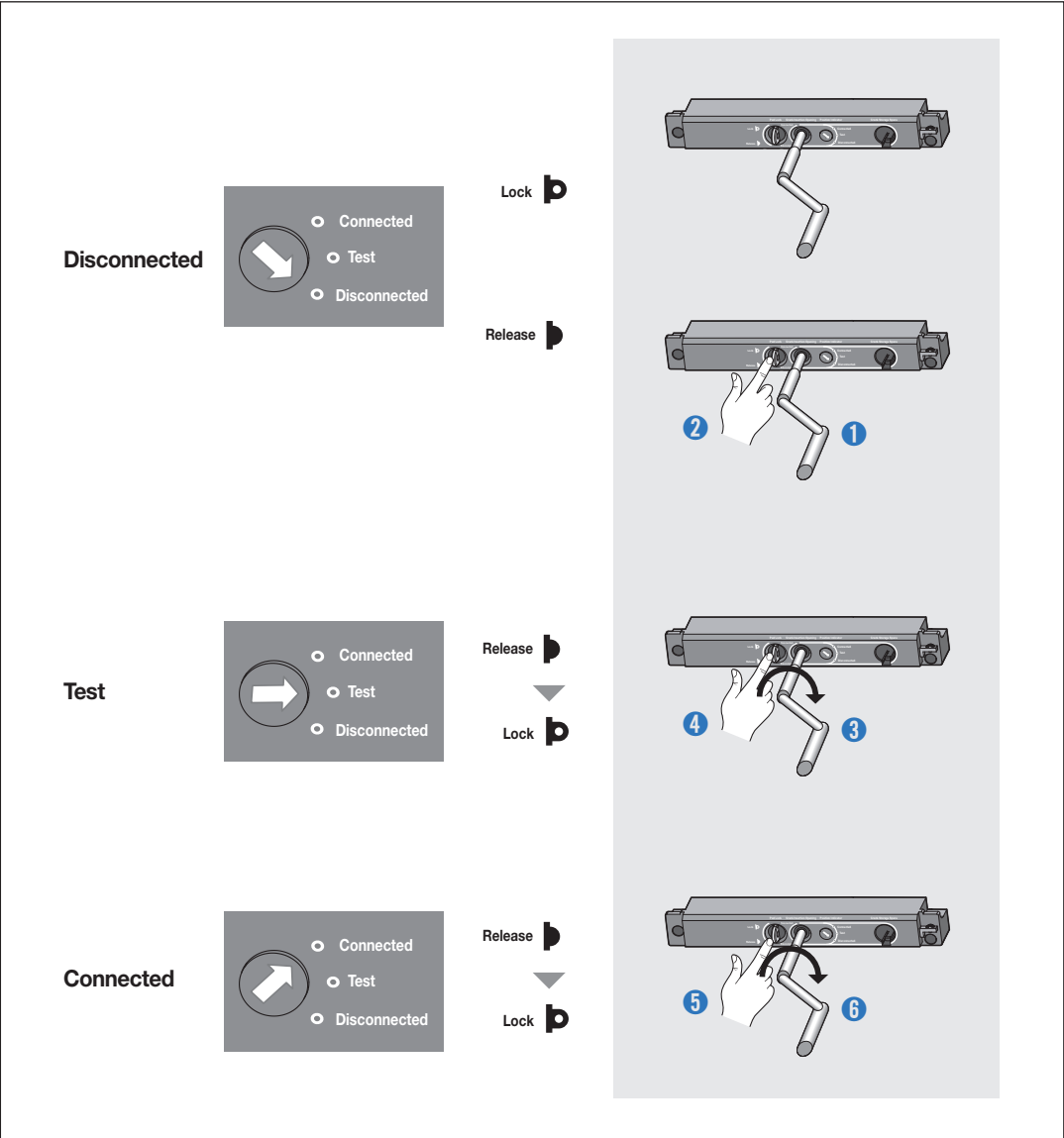

CAUTION

- 1. Please stop handle operation when draw in/out locking device protrudes.
- 2. Draw in or out by moving handle right or left side when draw in/out locking device can not be inserted.

7. OPERATION

7.2 Switching Operation

7.2.3 Draw-out operation (DISCONNECT position → TEST position → CONNECT position)

Draw-out operation procedure

- 1) Keep pushing the OFF button when the circuit breaker in a trip condition, and insert a handle to the body of the circuit breaker.
- 2) Check the Draw-out handle properly inserted and then push the lock plate and turn the Draw-out handle counterclockwise in order to insert the breaker.
- 3) When the breaker reaches the TEST position, the lock plate automatically projects and the Draw-out handle is locked.
- 4) Push in the lock plate and turn the Draw-out handle again counterclockwise until the lock plate projects, At this time, the Draw-out operation is finished with indicator which shows DISCONNECTED position.

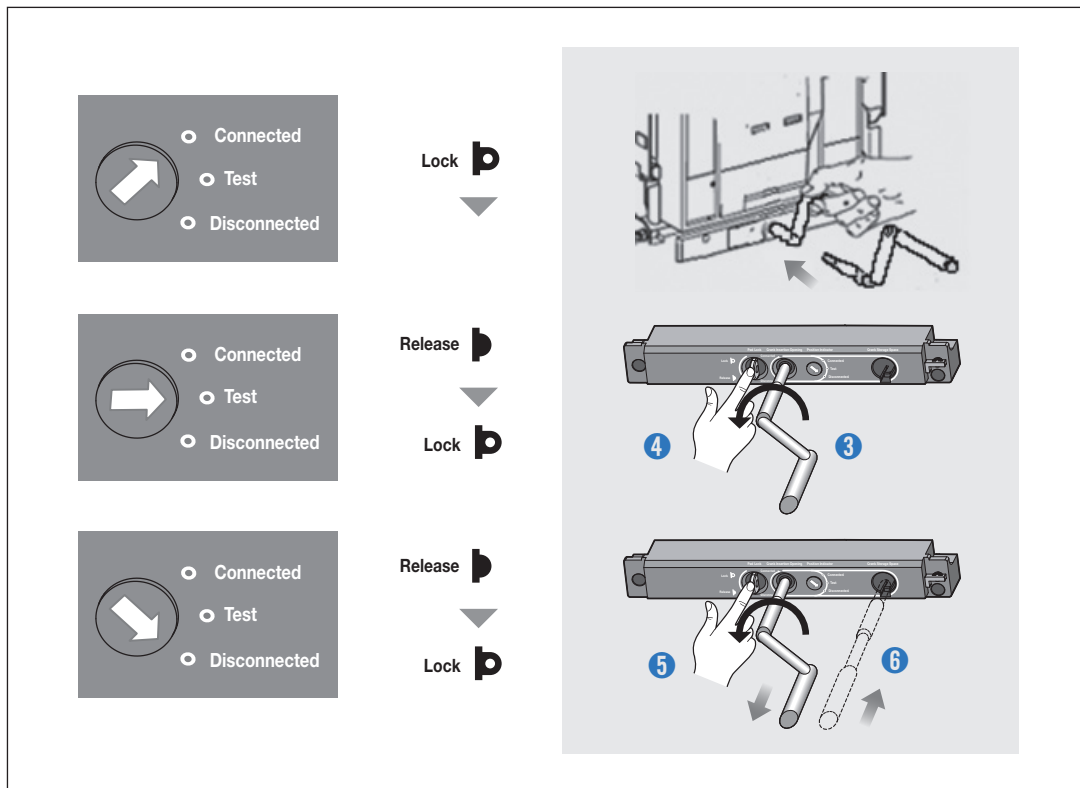
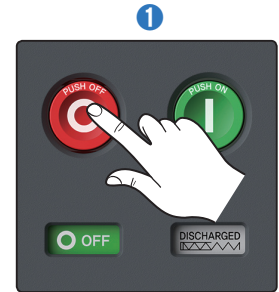

5. The circuit breaker indicated with 'DISCONNECTED' can be separated safely from the cradle by removing a draw in/out handle and releasing right and left locks.

6. Use a lifting hook to separate a circuit breaker from a cradle.



 **CAUTION**

The insertion and withdrawal must always be carried out with the apparatus open!

7.3 Space Heater

Under normal conditions, space heaters will be operating. Space heaters help reduce condensation by elevating the switchgear slightly above ambient temperature. If space heater fails, it should be replaced as soon as possible

7.4 BUS BAR

7.4.1 Accessing Bus bar

Live bus bar is behind bolted panels. Never remove these panels until the bus bar is de-energized. Review construction drawings before doing any work. These will show which barriers must be removed to reach any particular bus. The switchgear bus bar has been sectionalized to isolate any shorts, over voltages, or other issues and limit their effect. Always replace barriers once work is completed.

7.4.2 Accessing Bus bar

Megger bus bar phase to phase and phase to ground. Record the results as well as the temperature and the humidity in a maintenance log for the switchgear. If there is any possibility of deterioration of the insulation, the recording data would be helpful.

Inspect bus bar insulation for signs of deterioration. Cracking, crazing, tracking, residue deposition, or discoloration are signs of degradation. Pay special attention to areas around bus bar supports, bus insulators, bus bar joins, and bus bar connections. Wipe bus bar with clean rags after the inspection.

7.5 Ground & Test Devices

If it is required that the main busbar is earthed, then use the ground & test devices. For more information about ground & test devices, please refer to the ground & test devices manual.

TESTING AND INSPECTON

8. TESTING AND INSPECTON

Once the equipment is installed and all connections are finished, it should be tested and inspected before operation. Check the condition that the equipment is properly installed and all connections are placed correctly.

Guidance for testing devices such as relays, instruments, and meters are given in the instructions attached to the operation manual. The settings of the protective relay must be set according to the relay's setting table.

The operation of the breaker with its associated devices may be tested in the unit while the equipment is energized by racking the breaker into the test position and engaging the secondary coupler.

This is accomplished by lowering the handle on the right-hand side of the breaker mechanism and pushing forward until the coupler engages.

High potential tests to check the integrity of the insulation are not necessary if the insulation instructions in this book are carefully followed.

If the purchaser desires to make high potential tests, the test voltage should not exceed 75% of factory test voltage in accordance with ANSI Std.

Voltage transformers and control power transformers must be disconnected during voltage testing. When bus ground studs and caps are furnished, the caps are removed in order to attach grounding cables.

The purchaser must replace the ground stud caps after testing and/or maintenance is completed.

9. SAFETY PRECAUTIONS

Before operating or working on any electrical equipment, read this manual carefully to understand functions safety.

In this manual, safety precautions are divided into two types; **[DANGER]** and **[CAUTION]** These are defined as follows.

DANGER

A danger notice with this symbol indicates that neglecting the suggested procedure or practice could lead to serious injury.

CAUTION

A caution notice with this symbol indicates that neglecting the suggested procedure or practice could result in moderate or slight personal injury and/or property damage.

Note that failing to observe caution notices could lead to serious injury/damage in some situations.

The safety notice contains important safety information, so it must be read before any work begins.

9.1 Handling Electrical Machinery and Apparatus

In order to prevent accidents, anyone handling electrical machinery and apparatus must be thoroughly acquainted with the precautions noted below and with those in section 2, "Electric Shock Prevention".

Most accidents can be prevented with cautions. Always observe these precautions.

9.1.1 General Precautions

Observe the following precautions when performing maintenance or inspection in order to avoid electric shock or a short circuit. (Accidents can be caused by dropping metal tools, flashlights, or other conductive materials)

SAFETY PRECAUTIONS

9. SAFETY PRECAUTIONS

9.1 Handling Electrical Machinery and Apparatus

DANGER

Working Preparations

Treat electrical equipment as highly flammable material at all times.

- Do not smoke or use flames in the vicinity of the equipment.
- Wear a helmet, safety shoes, and work clothes when working on the equipment.
- Cut off the power supply. Otherwise there is the danger of electric shock from live bus-bars and other current carrying parts when the switchgear or other electrical panel is opened.
- Make sure there is no voltage in the circuit before any electrical work is done, and ground the panel. Make sure the panel is grounded. (use a voltmeter/circuit tester or the like).
- Never work on the charging area. (Except in an emergency)
- Inspect the surroundings for any possible dangers, and inform your associates of what you plan to do.
- Provide sufficient lighting for the work area.
- Maintain orderly work area. Do not scatter tools.
- Learn the proper way to use a circuit tester and other necessary tools.
- Read and understand section 2, “Electric Shock Prevention”.

CAUTION

Inspection and Maintenance

- Daily inspection
 - Check appearance for any damage. Pay special attention for noise, bad odor, and discoloration.
- Periodic inspection
 - Check each bus bar fixing section, device mounting section, and wiring section for any looseness. If any looseness is found, fasten the fixed bolts again.
 - Check appearance of each device (Air circuit breaker, protective relay, current & voltage transformer, fuse, module card, etc.) for any missing or damage. If any failure or damage is found, replace it with the spare parts.
 - Check each device (Air circuit breaker, protective relay, current & voltage transformer, fuse, module card, etc.) for noise, bad odor, or discoloration. If any noise, bad odor, or discoloration is found, replace with the spare parts.
 - Check the mechanical operating section of each device (vacuum circuit breaker, vacuum contactor, protective relay, etc.) for any mechanical malfunction in operation. If any malfunction is found, replace with the spare parts.

9. SAFETY PRECAUTIONS

9.1 Handling Electrical Machinery and Apparatus

9.1.2 Precautions for Hot-line Work

Never perform hot-line work unless it is unavoidable. If repair of live circuits or electrical devices is unavoidable, refer to the section 2, “Electric Shock Prevention” and follow the precautions listed below.



Hot-line Work

Treat electrical equipment as highly flammable material at all times.

- In the presence and/or under the supervision of competent supervision, perform the work while observing the following preparatory steps.
 - Provide sufficient lighting for the work area.
 - Remove wristwatches, rings, and other metal articles from the body.
 - Wear long sleeve work clothes that fit close to the body, and make sure clothing and shoes are dry.
 - Insulate yourself from the body, and place insulating material over any devices or structural components which may be accidentally touched.
 - Cover tools with vinyl tape wherever possible.
 - When doing electrical work, cover live part with insulating material or safety shutter to protect against dropped tools and scrap-wire, and inadvertent touching of live parts.
 - Place insulation between the live section of the circuit and the section to be worked on.
 - Wear rubber gloves on both hands (and wear rubber boots).
- Work with the dominant hand as much as possible, and take care not to lose your balance. A loss of balance due to the movement of the ship can cause an accident.
- If there is emergency situation, the site manager should cut the power off immediately and report the issue to the related personnel.

SAFETY PRECAUTIONS

9.1 Handling Electrical Machinery and Apparatus

9. SAFETY PRECAUTIONS

9.1.3 Guidelines for Fire Extinguishing

9.1.3 Guidelines for Fire Extinguishing

In the event of an electrical fire, quickly perform the following procedures.

DANGER

Fire Extinguishing

- Cut off the power to the circuit or device from which the fire began.
- Cut off the power to other circuits or devices which may be damaged by the fire, including those which could be damaged if the fire spreads.
- Do not cut off power to any devices which could cause a serious accident if deprived of power.
- Inform your supervisor or anyone close to the area of the fire.
- Use a fire extinguisher (powder or halide type) to fight the fire.
In a small room or section, there is the danger of asphyxiation from the fire extinguishing material, so be careful to avoid this.
In the case of electrical fires, always cut off the power supply first.
- Be careful when using water to extinguish an electrical fire.
The person fighting the fire could be electrocuted by current flow through the water.
- Think carefully when choosing between seawater and a fire extinguisher.
Once electrical devices have come in contact with seawater it is difficult to restore them to their original condition.
In some cases, a fire extinguisher is the best choice even if it requires more time than seawater to put out the fire.

9.1.4 Maintenance and Inspection of ACB

CAUTION

Maintenance of ACB

See the operating instructions of the particular breaker for correct maintenance, inspection, and replacement procedures.

For some types and mounting configurations, the entire switchgear must be cut off from the work for [Fixed type].

For others, only a restricted area of the switchgear must be cut off for [Draw-out type].

9. SAFETY PRECAUTIONS

9.1 Handling Electrical Machinery and Apparatus

9.1.5 Precautions for ACB Operation

DANGER

ACB Operation

- Before operating circuit breakers switches, confirm the following to avoid putting others in danger.
 - There will be no problems if any or all devices in the circuit receive power.
 - There are no other workers working on the same circuit.
If there are other workers working on the same circuit, inform them of what breaker or switch you will be operating and advise their caution.
 - The protective devices (protective relay, fuses, etc.) of all circuits are in order.
- Operate breakers and switches in the following manner.
 - Perform all operations with the dominant hand.
keep the other hand back and away from the breaker or switch except for operations that require both hands,.
 - Operate knife switches with one quick motion.

9.1.6 Precautions for Current & Voltage transformer Operation

CAUTION

CT & VT Operation

Do not open the secondary side of a current transformer.

If the secondary side must be opened for repair work, do not leave it opened; high voltage could be produced in the secondary side as current flows through the primary side. Periodically check the connections of the secondary side for tightness.

SAFETY PRECAUTIONS

9.1 Handling Electrical Machinery and Apparatus

9. SAFETY PRECAUTIONS

9.1.7 Precautions for Changing Fuses

DANGER

Changing Fuses

- Changing fuses
 - When removing a fuse, unscrew the fuse cap carefully.
 - While inserting the fuse into the fuse clip, do not allow the conductive part of the fuse to touch the gap between fuse clips. Otherwise, a short-circuit accident could arise!
 - When changing a fuse, do not make contact with charged devices or with any other live parts nearby, (i.e. bus-line etc.). Otherwise, electric shock could arise!
- Selecting the right spare
 - Use a spare of the same type and rated current as the blown fuse.

9.1.8 Other Precautions

CAUTION

Other Precautions

- Keep front doors and back covers or doors closed except when it is necessary to open them.
- Before starting electrical work, immobilize the moving parts by fastening the door or any objects that can move the cover of the switchgear.
- Do not remove protective plates or protective covers. If they must be removed, be sure to return them to their proper positions.
- Do not leave any tools or work materials on or around the switchboard or starter panel after work is completed.
- Always discharge capacitors before working on capacitor circuits.

9. SAFETY PRECAUTIONS

9.2 Electrical Shock Prevention

9.2.1 General Information on Electric Shock

- The Danger of Electricity
 - Receiving an electric shock is extremely dangerous.
Even a relatively small amount of current can be fatal if it passes through the head, lungs, or other vital organs.
 - 220V AC is more dangerous than we think.
 - At 220V AC, 60/50 Hz, even 50milliamperes (mA) is dangerous and 50~100mA can cause a fatal electric shock.
- The Symptoms of Electric Shock

The symptoms described below must be treated immediately with artificial respiration or Cardiopulmonary Resuscitation (CPR) until the victim recovers. These are symptoms of electric shock and should not be confused with death. It is usual for a person suffering from these symptoms to recover even after several hours of artificial respiration or cardiopulmonary resuscitation (CPR).

The Symptoms are listed in order from mild to most serious case.

 - Breathing stops.
 - Normal breathing can usually be restored after continuing artificial respiration for a short while.
 - Breathing stops, face is pallid, and pulse is very weak or undetectable.
 - Totally unconscious.

In the worst of cases, the body of the victim may become rigid within two or three minutes after the shock.

9.2.2 Prevention of Electric Shock

Anyone who is operating or performing maintenance or repairs on electrical equipment or anyone who supervises people doing such work should take the following measures to prevent electric shock accidents.



Prevention of Electric Shock

- Never estimate the voltage applied to the circuit until the voltage has been confirmed (measured).
- Always cut off the power supply and confirm that there is no voltage applied to the circuit before any electrical work is done. Most accidents occur because the power is mistakenly assumed to be off.
- Always use rubber gloves, rubber boots, and an insulation mat when doing electrical work.
- Tag the power supply switch when doing electrical work.
(ex. "Do Not Turn on Power: Maintenance Work")
- If someone turns on the power during maintenance may cause serious accident.
- Operate switches with the dominant hand while holding the other hand at the back away from the body.
- The site manager should be available near the Switchgear installed area, so that they can cut off the power immediately if an accident occurs.

MAINTENANCE

10. MAINTENANCE

10.1 General

Maintenance serves to preserve trouble-free operation and achieve the longest possible working life of the switchgear. It comprises the following closely related activities;

- **Inspection : Determination of the actual condition**
- **Servicing : Measures to preserve the specified condition**
- **Repair : Measures to restore the specified condition**

※ **Note:**

When carrying out all maintenance work, the regulations in the country of installation must be strictly complied with.

Maintenance work may only be performed in a careful manner by trained personnel familiar with the characteristics of the individual switchgear, in accordance with all relevant ANSI safety regulations and those of other technical authorities, and with other overriding instructions. It is recommended that LS Electric service personnel are called in to perform the servicing and repair work detailed below.

The inspection and service intervals for some of the equipment/components (e.g. parts subject to wear) are determined by fixed criteria, such as switching frequency, length of service, and number of short-circuit breaking operations. On the other hand, for other parts the length of the intervals may depend, for example, on the different modes of operation in individual cases, the degree of loading, and also environmental influences (including pollution and aggressive air).

10.2 Classification of Periodic Inspection

- Where necessary, the working area must be isolated and secured against reconnection in accordance with the Safety Regulations specified by ANSI and appropriate national standards before inspection.
- Correct condition of the switchgear should be monitored by regular inspections.
- Under normal operating conditions, inspection should be carried out once every four years by specially trained professional electricians.
- Under abnormal operating conditions (including adverse climatic conditions) and/or special environmental stresses (heavy pollution and aggressive atmosphere, among others), inspection may be necessary at shorter intervals.
- Periodic inspection is primarily a visual inspection for grime, corrosion, and moisture.
 - Effects of high temperature on the main circuits.
 - Traces of partial discharge on the insulating material parts.
 - Traces of leakage current on the insulating material parts.
 - Surfaces of the contact systems.
- However, inspection must also include correct mechanical/electrical operation of the following parts : switching devices, actuating, interlocking, protection, and signaling devices.

10. MAINTENANCE

10.2 Classification of Periodic Inspection

CAUTION

Instrument transformer circuit

- With regard to the switching devices, their separate Instruction manual should be followed.
- Check all switchgear accessories and auxiliary devices (e.g. storage batteries).
- Partial discharge must not occur on the surfaces of equipment at operating voltage. It can be detected by characteristic noises, a clearly perceptible smell of ozone, or visible glowing in the dark.
- Visually check the contact system. We recommend turning the contact system alternately in order to clean the inner contact points of the contact system.
The contact points should be cleaned if signs of overheating (discolored surface) are visible.
- If any irregular conditions are detected, then relative repair measures must be taken.

< Table B > For inspection, restricted condition is necessary as follows

Classification of inspection	Restricted Condition	Opening and closing of door	Separation of cover	Un-interruption of power	Circuit power failure	Interruption of main bus power	Inspection period
Visual inspection	0	-	0	-	-	-	Once /Month
Monthly inspection	0 (Note 2)	-	0	-	-	-	Once /Month
Annual inspection	0	0	-	0	0 (Note 3)	-	Once /Year
Temporary inspection	0	0	-	0	0	-	-

※ Note:

1. Choose the inspection period by referring to the Table B.
2. At the time of power failure, it is possible to check whether the MCC door is opened and also it is recommended to check whether the door is opened once a month.
3. Power outage is unusual, but the inspection under power outage is carried out necessarily every two years.

10.2 Classification of Periodic Inspection

10. MAINTENANCE

10.2.1 Visual inspection

Check the devices which is installed on the door, for example, meter, lamp, switch and so on whether it is damaged or not.

10.2.2 Planned inspections

These inspections are considered planned examinations, required to confirm that system components are functioning as required. The inspections are scheduled, taking into account operating requirements, environmental conditions etc., at regular intervals with precise work instructions and systematic checks to be undertaken.

10.2.3 Planned inspections routine

This consists of periodical inspections on a monthly and annual basis.

10.2.4 Monthly inspections

These involve visual inspections requiring doors to be opened which are admissible without interrupting the supply, and where necessary.

- Indication lamp replacement
- Correct any observed abnormality

10.2.5 Annual inspections

These require a full operational test to be performed ensuring all equipment is fully and efficiently operating without any abnormalities.

All equipment and components should be inspected according to manufacturer's data.

Where equipment is required to maintain its supply, caution should be exercised during inspection.

If a full inspection is not possible as energization needs to be maintained, then a visual inspection should be performed, and a full operational inspection must be rescheduled for more convenient time in the near future.

10. MAINTENANCE

10.3 Maintenance and Repair of Equipment

Restrictions imposed by the equipment should be highlighted where applicable.

10.3.1 Isolating procedure of the main bus bar for SWGR

- Open the main circuit breaker in order to de-energize the main circuit.
- If necessary, check the de-energized status by using Voltage test meter.
- Discharge the remaining current from the capacitor to earth after 2 minute period has elapsed after isolation for safety.
- To prevent mis-operation, you need to lock the breaker that is disconnected in the “OFF” position and post a warning sign “MEN AT WORK”.

CAUTION

Without power interruption from distribution transformer secondary side, do not remove the insulation cover surrounded by main incoming bus bar.

10.3.2 General safety procedures

It is mandatory to have the cooperation of related personnel for the safety of humans and equipment. Therefore, it is expected that the person working in the plant area will follow the safety regulations outlined in this procedure.

Before commencing any tests, commissioning, or operation activities the following general conditions shall be applied.

It is necessary for the operator to understand the construction of equipment and operation methods for safety.

- The working area shall be clear and free from debris and left over materials.
- Access to all working areas and equipment shall be clear.
- Ventilation system shall be satisfactory.
- Danger/warning signs as applicable shall be posted.
- Entry to the working/operation area shall be restricted to authorized persons only.
- Firefighting facilities shall be available where applicable.
- Check strict and accurate communication with relative quarters.
- Ensure equipment is de-energized (electrically isolated). The circuit diagram should be checked to see if the primary power is alive or not. Also, it is required to check the grounding to test equipment, and then check the de-energized status by using the Test meter. To ensure maximum security, all energized zones shall be kept locked. Key will be stored in the control of the responsible person as designated in this document.

MAINTENANCE

10. MAINTENANCE

10.4 Repair of Surface Damage

Repair of surface damage;

- Carry out repair work immediately after a defect has been discovered.
- Completely remove all rust from damaged paintwork areas on steel sheet and other steel parts by mechanical means (example: with a wire brush).
- Lightly grind the surrounding paint coat and carefully degrease the entire area.
Then apply an anti-rust primer immediately, and leave it until hardened. Finally, apply the top coat. Only use suitable and compatible paint products.
- Apply the top coat in standard RAL 7032 color, or the relevant special color.

10.5 Table of Scheduled Maintenance

Items to be checked	Check contents & Interval (1 time)				
	Visual	Operating (Adjusting)	Measuring (Megger)	Replace	Remarks
Switch board	2 months				
Air Circuit Breaker	2 months	1 year	2 year	According to its instruction manual	
Voltage transformer	2 months		2 year	Depend on megger value	
Current Transformer	2 months		2 year	Depend on megger value	
Push Button Switch	2 months	1 year		250,000 times	
Fuses	2 months				
Fluorescent Lamp	2 months	1 year			
Instrumentation parts	2 months	1 year			

10. MAINTENANCE

10.6 Preventive Maintenance Procedures of Various Equipment

10.6.1 Switchgear

No.	Items	Interval (1 time)	Inspection Method	Remarks
1	Rust, damage	2 months	1) Any rust, damage on metal part? 2) Any rust, damage on metal fixtures? 3) Any damage on peep hole, waterproof rubber, etc.	1) Clean the parts with damage. Repair when metal parts are damaged. 2) Clean the rust from hinges, handle, etc. because this is the cause of malfunctions. 3) Clean the inside and outside of the peep hole.
2	Imperfect function	Do.	Any fault in door, handle, latch, hinge, etc.	Repair the damaged parts.
3	Display	Do.	Any missing lamps, display or unclear?	
4	Lock device	Do.	Any abnormality in lock device?	Check the function of the locking device, etc. and confirm the key storage.

10.6.2 Air Circuit Breaker and Electromagnetic Contactor

※ **Note:**

See Manufacturer's Operation & Maintenance Manual for Detail

MAINTENANCE

10. MAINTENANCE

10.6 Preventive Maintenance Procedures of Various Equipment

No.	Items	Interval (1 time)	Inspection Method	Remarks
1	Switch operation	1 year	<p>Operate the switch several times and check the following points.</p> <p>1) Any fault with on and off time. Any variation?</p> <p>2) Any abnormal noise?</p> <p>3) Any abnormal vibration?</p> <p>4) Normal ON control voltage and pressure for power operation</p> <p>5) Is trip circuit normal?</p>	<p>1) Listen to the sound as it goes on and off. If there is any abnormality, perform a precise inspection.</p> <p>2) Perform a precise inspection for any faults other than the characteristic noise and vibration of the breaker.</p> <p>3) Pay attention to spark noise due to loose terminals, vibration due to poor fixing of the breaker, etc.</p> <p>4) Measure the control voltage and adjust the voltage of the power supply (battery, etc.) if it does not stand $\pm 5\%$ of the rated value.</p> <p>5) Perform an automatic trip test with the protection relay contact circuit. It's OK if it trips.</p>
2	Display unit check	2 months	Does circuit breaker display lamp match main circuit operation?	Clean the gaps between the contacts of the auxiliary switch because they easily become dirty. If it is not normal even after cleaning the display lamp. Display and auxiliary switch, check the circuit contacts, etc.
3	Loose parts	Do.	<p>1) Any loose terminals in the main circuit?</p> <p>2) Any looseness in auxiliary switch, control circuit terminals, control circuit parts, and their fittings?</p> <p>3) Any looseness, bend, etc. in circuit breaker bolts, nuts etc.</p>	2) 3) make sure all parts to be tightened.

10. MAINTENANCE

10.6 Preventive Maintenance Procedures of Various Equipment

No.	Items	Interval (1 time)	Inspection Method	Remarks
4	Deformation	2 months	Any deformation of bus high and main circuit conductor by electromagnetic force when there is large current cut-off?	<p>Check deformation of the inside when short circuit occurs.</p> <p>Replace parts, and perform a precise examination depending on the degree of deformation at the same time.</p> <p>The circuit breaker may have to be replaced.</p>
5	Damage	Do.	<p>1) Dose the abrasion between the main contactor and housing exceed the limit?</p> <p>2) Any damage or deformation on the spring of contactor?</p>	<p>1) The limit of the abrasion between main contactor and housing by the cut-off current and cut-off circuit.</p> <p>Refer to the manufacturer's instruction manual and repair or replace them and perform a precise examination.</p> <p>2) If there is damage or deformation on the contacts or spring, replace and perform a precise examination.</p>
6	Insulation resistance	2 years.	<p>With insulation resistance meter (megger).</p> <p>* High voltage circuit : 1000V or more</p> <p>* Low voltage circuit : 500V</p> <p>after cleaning the insulator and insulation material with a dry cloth.</p>	<p>Use the following as a guide for insulation resistance between the main circuit and the ground.</p> <p>Between the contacts of same phase of main circuit(100M ohm).</p> <p>Between the main circuits of different phase</p> <p>Between the control unit conductor and ground (1M ohm)</p>

MAINTENANCE

10. MAINTENANCE

10.6 Preventive Maintenance Procedures of Various Equipment

10.6.3 Current Transformer (CT)

No.	Items	Interval (1 time)	Inspection Method	Remarks
1	External deformation	2 months	<ol style="list-style-type: none"> 1) Any internal abnormality or swelling or cracks in rubber, compound, resin, etc. due to excessive heat of primary terminals? 2) Any traces of electric discharge affected by dirt and moisture, salt, gas, etc for long time. 	<ol style="list-style-type: none"> 1) Do not reuse damaged equipment badly affected by external shock or internal malfunction. After replacing, remove the cause of the trouble such as load, wiring, etc. before operating. 2) Replace deformed equipment showing traces of electric discharge. Carefully check the surrounding conditions, etc., to see that it doesn't happen again.
2	Dirty, damage	Do.	<ol style="list-style-type: none"> 1) Any dirt, damage, etc.? 2) Is fuse OK? 3) Anything sticking to conductors, core fittings, bolts, nuts, etc., any damage to them, any of them missing, any cracks, etc.? 	<ol style="list-style-type: none"> 1) Clean because dirt may become the cause of discharge. Check for cracks while cleaning and replace anything damaged. 2) Be careful with poor fuse contact in a high voltage circuit because it may be the cause of different phase flashover accompanied by electric discharge.
3	Heat discoloration	Do.	Any discoloration of conductors due to excessive heat?	Perform a precise examination when there is heat discoloration on the conductor.
4	Rust	Do.	Any rust on conductors?	Clean when there is rust on the conductors, core, and structure and repair the painted parts.
5	Looseness	Do.	<ol style="list-style-type: none"> 1) Any looseness of primary and secondary terminal fittings? 2) And looseness in mounting bolts? 	<p>Be careful because looseness of the primary and secondary terminals may cause accidents.</p> <p>Tighten the mounting bolts, etc.</p>
6	Insulation resistance	2 years.	<ol style="list-style-type: none"> 3) Any looseness in fuse mountings? With an insulation resistance meter (megger) exceeding 1000V. Do after cleaning the insulation material with a dry cloth. 	<p>Use the following guide for insulation resistance.</p> <p>Between the primary line and the secondary line (30 Megger ohm)</p> <p>Between the secondary line and the outside box (2 Megger ohm)</p>

10. MAINTENANCE

10.6 Preventive Maintenance Procedures of Various Equipment

10.6.4 Switch, Contactor

No.	Items	Interval (1 time)	Inspection Method	Remarks
1	Switch operation check	1 year	Any abnormality when operating several times?	Check the condition of the contactors and mechanism in response to manual operation.
2	Heat discoloration	2 months	Any discoloration of contacts?	Replace if there is discoloration in the switch and contacts.
3	Abnormal smell	Do.	Any rust on conductors, metal fittings, mounting fixtures?	When there is an abnormal smell, check the built-in coil bush, insulation material and other hidden parts.
4	Rust	Do.	Any rust on conductors, metal fittings, mounting fixtures?	Aluminum, copper, etc., are easily rusted and corroded by moisture and gas. Cleaning is required during inspection.
5	Contact	Do.	1) Any fault in contact pressure due to spring fatigue, copper plating, etc. 2) Any abnormality due to wear in contact points, contact deformation.	1) With a self-contacting type, lightly tap the conductor part to check if there is any fault in the elasticity comparing that sound with the metallic sound of a good contact. 2) Replace any worn contacts.
6	Looseness	Do.	Any loose bolts, nuts in moving parts, conductor connections, etc.	Securely tighten any loose ones

MAINTENANCE

10. MAINTENANCE

10.6 Preventive Maintenance Procedures of Various Equipment

10.6.5 Busbar

No.	Items	Interval (1 time)	Inspection Method	Remarks
1	Heat discoloration	2 months	Any discoloration in auxiliary bus bar, insulated bus bar?	If there is discoloration in the bus bar, check whether the load current is too large for the current capacity of the bus bar.
2	Dirty / foreign matter	Do.	Any dust or foreign matter in all bus bar.	Bus bar must be kept in a clean environment, it is necessary to clean in a no-voltage condition.
3	Contact looseness	Do.	Any looseness in contacts of clamps, mounting bolts etc.	Loose bus bar contacts are the cause of accidents such as fusing due to bus bar current. Be sure to check when there is a chance with no-voltage.

11. TREATMENT

11.1 Daily and Instant Treatment

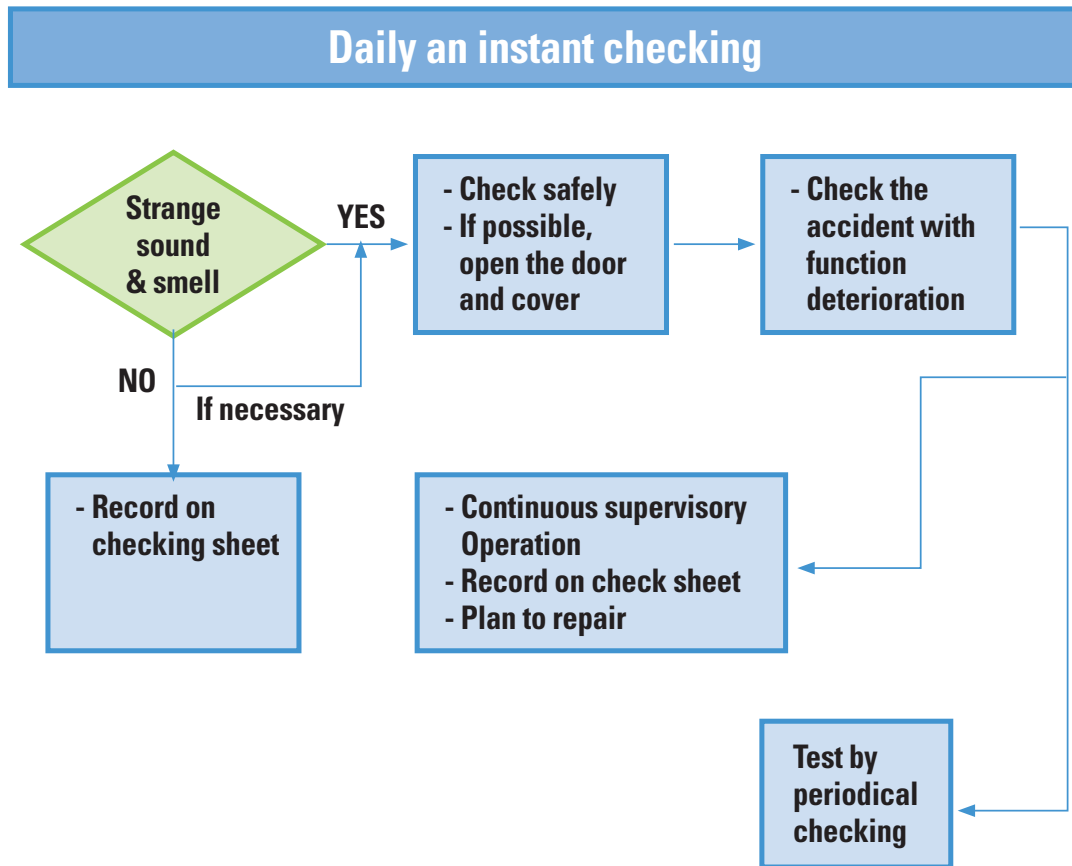

TREATMENT

11. TREATMENT

11.2 Periodical Treatment

No.	Treatment	Contents and Attention
1	Cleaning	<p>1) It is recommended to use attraction method in case of using the air or ejecting method.</p> <p>※ Be aware of humidity and pressure of air.</p> <p>2) Before opening the door and cover, clean the dust and other dirt.</p> <p>3) Clean the insulation material in cross direction between the live parts.</p> <p>4) It is recommended to use neutral cleaning materials.</p>
2	Bolt joint (busbar, construction)	<p>A. JOINT OF BUS BAR CONNECTION</p> <p>1) Method</p> <ol style="list-style-type: none"> Joint with proper torque wrench with adequate torque. Joint to turn the nut, not bolt. Be cautious of not tightening one side only, if using more than 2 bolts <p>B. CHECKING OF BOLT JOINTING</p> <p>It is necessary to check whether the bolt is jointed with defined torque because incomplete jointing of bolt may cause a huge accident. Therefore, Bolts and nuts are necessary to be marked in red after the joint works.</p> <p>※ BOLT joint torque shall follow in accordance with Table A.</p>  <p>The diagram shows a perspective view of a bolt and nut being tightened onto a busbar. A red check mark is drawn on the busbar surface next to the bolt head. A line points from the text 'Check Mark' to this red check mark.</p>

11. TREATMENT

11.2 Periodical Treatment

No.	Treatment	Contents and Attention																																
3	Repair of insulation Materials	<p>1) When the porcelain insulator is polluted by dust, clean it by referring to the Treatment above.</p> <p>2) When the looseness occurs due to the worn-out resin or wooden materials, then change the part by referring to Treatment 5.</p> <p>3) Damage, crack, and variation of insulation material require replacement too.</p> <p>4) The dropping of insulation resistance requires checking the table below. Then compare and check with previous data, and treat adequately.</p> <p>5) The value of insulation resistance may be influenced by temperature, humidity, and surface condition. Therefore it is difficult to decide the quality, but refer to the following values.</p> <p>a) Panel</p> <ul style="list-style-type: none"> - Condition: 68°F(20°C) 65% RH - High-voltage circuit: More 5M ohm - Low voltage circuit: <table border="1" style="width: 100%; border-collapse: collapse;"> <thead> <tr> <th colspan="2">Voltage class</th> <th>insulation Resistance value</th> </tr> </thead> <tbody> <tr> <td rowspan="2">Below 300V</td> <td>voltage to earth below 150V</td> <td>0.1 M ohm</td> </tr> <tr> <td>Others</td> <td>0.2 M ohm</td> </tr> <tr> <td colspan="2">330V ~ 600V</td> <td>0.4 M ohm</td> </tr> </tbody> </table> <p>b) Main circuit breaker and isolator</p> <table border="1" style="width: 100%; border-collapse: collapse;"> <thead> <tr> <th></th> <th>insulation Resistance value</th> <th>Tester</th> </tr> </thead> <tbody> <tr> <td>Main circuit</td> <td>More 500M ohm</td> <td>1000V</td> </tr> <tr> <td>Control circuit</td> <td>More 2M ohm</td> <td>500V</td> </tr> </tbody> </table> <p>c) Measuring instrument</p> <table border="1" style="width: 100%; border-collapse: collapse;"> <thead> <tr> <th>Base temp</th> <th>20°C</th> <th>30°C</th> <th>40°C</th> </tr> </thead> <tbody> <tr> <td>- Enclosure - Between primary and secondary winding</td> <td>500M ohm</td> <td>250M ohm</td> <td>130M ohm</td> </tr> <tr> <td>- Between enclosure and secondary winding</td> <td colspan="3" style="text-align: center;">2M ohm</td> </tr> </tbody> </table>	Voltage class		insulation Resistance value	Below 300V	voltage to earth below 150V	0.1 M ohm	Others	0.2 M ohm	330V ~ 600V		0.4 M ohm		insulation Resistance value	Tester	Main circuit	More 500M ohm	1000V	Control circuit	More 2M ohm	500V	Base temp	20°C	30°C	40°C	- Enclosure - Between primary and secondary winding	500M ohm	250M ohm	130M ohm	- Between enclosure and secondary winding	2M ohm		
Voltage class		insulation Resistance value																																
Below 300V	voltage to earth below 150V	0.1 M ohm																																
	Others	0.2 M ohm																																
330V ~ 600V		0.4 M ohm																																
	insulation Resistance value	Tester																																
Main circuit	More 500M ohm	1000V																																
Control circuit	More 2M ohm	500V																																
Base temp	20°C	30°C	40°C																															
- Enclosure - Between primary and secondary winding	500M ohm	250M ohm	130M ohm																															
- Between enclosure and secondary winding	2M ohm																																	

TREATMENT

11. TREATMENT

11.2 Periodical Treatment

No.	Treatment	Contents and Attention			
4		- Mold Type -			
		Base temp	20°C	30°C	40°C
		- Enclosure - Between primary and secondary windings	200M ohm	100M ohm	50M ohm
	- Between enclosure and secondary 2M ohm windings	2M ohm			
5	replacing parts	1) Check the type and function. 2) During the change of parts, make sure that misconnection does not occur, and follow the instruction of tightening bolts and torques. 3) If the adjustment is necessary, set the value properly after the change is done. 4) In case of welding, make sure skilled personnel do the job.			



LS ELECTRIC America Inc. Chicago Head Office

625 Heathrow Dr, Lincolnshire, IL 60069, USA

Tel: 1-224-352-2265 E-Mail: sales.us@lselectricamerica.com

Headquarter

127 LS-ro (Hogye-dong) Dongan-gu, Anyang-si, Gyeonggi-Do, 14119, Korea

Seoul Office

LS Yongsan Tower, 92, Hangang-daero, Yongsan-gu, Seoul, 04386, Korea

TEL: 82-2-2034-4916, 4684, 4429

China

LS ELECTRIC (Dalian) Co., Ltd.

+86-411-8730-7560

china.dalian@lselectric.com.cn

LS ELECTRIC (Wuxi) Co., Ltd.

+86-510-8534-6666

china.wuxi@lselectric.com.cn

LS ELECTRIC (Lishui) Co., Ltd.

+86-133-6207-7980

china.lishui@lselectric.com.cn

Shanghai Office

+86-21-5237-9977

china@lselectric.com.cn

Beijing Office

+86-10-5095-1631

china@lselectric.com.cn

Guangzhou Office

+86-20-3818-2883

china@lselectric.com.cn

Qingdao Office

+86-532-8501-2065

china@lselectric.com.cn

Chengdu Office

+86-28-8670-3201

china@lselectric.com.cn

Nanjing Office

+86-25-8467-0005

china@lselectric.com.cn

India

India Office

+91-80-6142-9108

Info_india@ls-electric.com

Indonesia

PT. LS ELECTRIC INDONESIA

+62-21-2933-7614

indonesia@ls-electric.com

PT SYMPHOS ELECTRIC

+62-81-1900-1474

marketing@symphos-weltraf.com

Italy

Italy office

+39-030-8081-833

italia@ls-electric.com

Japan

LS ELECTRIC Japan Co., Ltd.

+81-3-6268-8241

japan@ls-electric.com

Tokyo Office

+81-3-6268-8241

tokyo@ls-electric.com

Netherlands

LS ELECTRIC Europe B.V.

+31-20-654-1424

europartner@ls-electric.com

Russia

Moscow Office

+7-499-682-6130

info@lselectric-ru.com

Singapore

Singapore Office

+65-6958-8162

singapore@ls-electric.com

Spain

LS ELECTRIC IBERIA S.L.U.

+34-910-28-02-74

iberia@ls-electric.com

Thailand

Bangkok Office

+66-2-128-0295

thailand@ls-electric.com

Türkiye

LS ELECTRIC Türkiye Co., Ltd.

+90-212-806-1252

turkiye@ls-electric.com

U.A.E

LS ELECTRIC Middle East FZE (Dubai)

+971-4-886-5360

middleeast@ls-electric.com

USA

LS ELECTRIC America Inc.

+1-800-891-2941

sales.us@lselectricamerica.com

LS ENERGY SOLUTIONS LLC

+1-980-221-0654

cmfeldman@ls-es.com

MCM Engineering II

+1-435-865-0125

sales.us@lselectricamerica.com

America Western Office

+1-949-333-3140

america@ls-electric.com

America Bastrop Campus

+1-224-352-2265

sales.us@lselectricamerica.com

Vietnam

LS ELECTRIC Vietnam Co., Ltd.

+84-222-2221-110

vietnam@ls-electric.com

Hanoi Sales Office

+84-24-6275-8054

vietnam@ls-electric.com

Ho Chi Minh Sales Office

+84-3823-7890

vietnam@ls-electric.com

Specifications in this catalog are subject to change without notice due to continuous product development and improvement

© 2024. 05 LS ELECTRIC Co., Ltd. All rights reserved. / English (01) 2021. 05 Staffcom

www.LSElectricAmerica.com