

**Beyond** X™

**Susol UL 27kV  
MV Switchgear**

Installation Operation Maintenance Manual



**LS** ELECTRIC



# Solution Power S27 UL Medium Voltage Switchgear Installation Operation Maintenance Manual

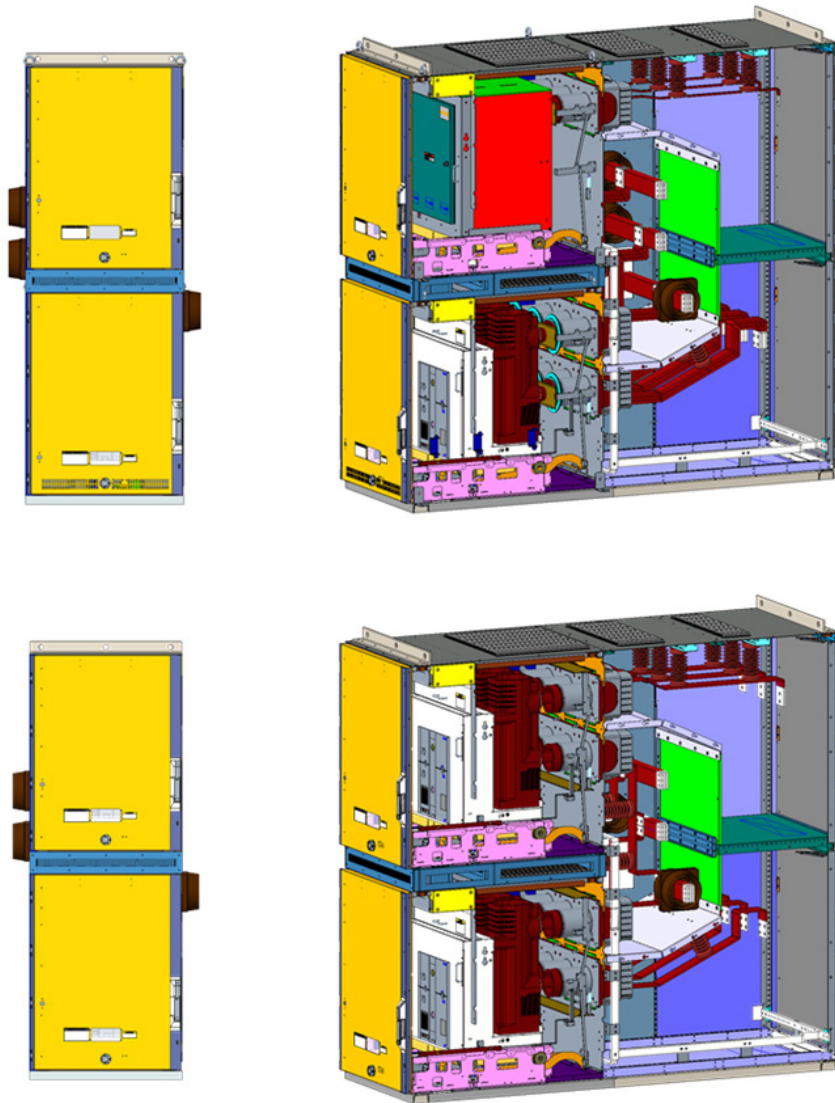

**LS**<sup>→</sup>ELECTRIC

# Table of content

---

- 1. SAFETY PRECAUTIONS**
  - 1.1 Handling Electrical Machinery and Apparatus ..... 8
  - 1.2 Electrical Shock Prevention ..... 14
- 2. SWITCHGEAR DESCRIPTION**
  - 2.1 Panel description ..... 16
    - 2.1.1 Single line diagram for each section ..... 16
  - 2.2 Applied standards ..... 17
  - 2.3 Environmental and operating conditions ..... 17
  - 2.4 Technical data ..... 17
  - 2.5 Name plate ..... 17
  - 2.6 Dimension and weights ..... 18
  - 2.7 Intended use ..... 21
  - 2.8 Disposal after the end of service life ..... 21
- 3. PACKING**
- 4. RECEIVING, HANDLING & STORAGE**
  - 4.1 Receiving ..... 23
  - 4.2 Handling ..... 23
  - 4.3 Storage ..... 25
  - 4.4 Storage guarantee ..... 26
- 5. INSTALLATION**
  - 5.1 Installation ..... 27
  - 5.2 Foundations ..... 29
  - 5.3 Placement ..... 31
- 6. ASSEMBLY OF THE MCSG**
  - 6.1 Safety provisions ..... 32
  - 6.2 Important instructions for assembly ..... 32
  - 6.3 Assembly ..... 32
    - 6.3.1 Indoor Assembly ..... 32
    - 6.3.2 Main Bus connection between sections ..... 32
    - 6.3.3 Control wiring Interconnection ..... 34
    - 6.3.4 Ground bus ..... 34
    - 6.3.5 Current Transformers ..... 34
    - 6.3.6 Fuse ..... 35
    - 6.3.7 Key Interlocks(If provided) ..... 35
    - 6.3.8 Primary Cables Connection ..... 35
    - 6.3.9 Bus Duct Connections ..... 36
    - 6.3.10 Connection of Control Cable ..... 36
    - 6.3.11 Cleaning ..... 36
    - 6.3.12 Pre-operational Testing and Inspections ..... 36
    - 6.3.13 Primary circuits ..... 36
  - 6.4 Requirements regarding the switchgear room ..... 37
  - 6.5 Fastening screws for connecting with other panels ..... 39
  - 6.6 Busbar assembly ..... 39
  - 6.7 Mounting the Ground(earth) bus ..... 41

## 7. ACCESSING THE MAIN CIRCUIT COMPARTMENTS

7.1 Safety provision and important information .....	42
7.2 Accessing cable compartment .....	43
7.3 Accessing VT compartment .....	44
7.4 Accessing the VCB compartment .....	45
7.4.1 Opening and closing door of VCB compartment .....	45
7.5 Inserting and removing VCB from the panel .....	46
7.6 Accessing busbar compartment .....	47
7.6.1 Accessing busbar compartment through cable compartment ..	48

## 8. OPERATION

8.1 Commissioning .....	49
8.1.1 Preparatory work .....	49
8.1.2 Start-up .....	50
8.2 Switching operation .....	51
8.2.1 Racking-in/out Operation .....	51
8.2.2 Manual racking in/out operation .....	53
8.3 Space Heater .....	57
8.4 Busbar .....	57
8.4.1 Accessing Busbar .....	57
8.4.2 Busbar inspection and cleaning .....	57
8.5 Voltage transformer .....	57
8.5.1 Block-type VT truck(1-high) fuse replacement manual .....	57
8.5.2 Gun-type VT truck(1/2-high) fuse replacement manual .....	59
8.6 Ground & Test devices .....	60
8.7 Breaker Lifter .....	60
8.8 Motor Control Racking System .....	60

## 9. INSPECTION & MAINTENANCE

9.1 General .....	61
9.2 Classification of Periodic Inspection .....	63
9.3 Maintenance and Repair of Equipment .....	66
9.4 Repair of Surface Damage .....	67
9.5 Table of Scheduled Maintenance .....	67
9.6 Preventive Maintenance Procedures of Various Equipment .....	68

## 10. TREATMENT

10.1 Daily and Instant Treatment .....	74
10.2 Periodical Treatment .....	75

# SAFETY PRECAUTIONS

## 1. SAFETY PRECAUTIONS

Make sure to comply with safety precautions to prevent accidents or risks in advance and use the product safely and correctly.

Precautions are divided into three categories - “danger”, “warning” and “caution”, which have the following meanings.



**DANGER**

Not heeding this danger sign will result in immediate serious injury or fatality.



**WARNING**

Not heeding this warning sign may result in immediate serious injury or death.



**CAUTION**

Not heeding this caution sign may result in minor injury or product damage.

The meanings of the markings shown below and affixed to the product are as follows:



This marking is intended to warn users of potentially hazardous items and operations. If this marking is displayed, read it carefully and follow the instructions to avert a dangerous situation.



This marking indicates the risk of electric shock under certain conditions, requiring users' keen attention.



## WARNINGS

Medium voltage switchgear is safe and effective when proper precautions are taken. When hazardous voltage and energy levels exist, it may cause death or injury if precautions are not followed

1. Never work around a live or energized bus. Do not remove bolted cover, bolted doors, or bolted access plates when the equipment is energized. The live bus is enclosed behind metal panels and these panels should not be removed unless the bus is de-energized.
2. Never use a circuit breaker rated at a different voltage from the equipment. Never use a lower interrupting rating than the system is designed for.
3. Only qualified personnel should maintain or operate switchgear. Maintenance personnel should be qualified to work with medium voltage equipment and familiar with switchgear in general. Operators should be trained in the proper use of switchgear and its components. Both should have electrical shock and burn medical training.
4. Do not touch shutters when switchgear is energized. Extremely high voltage flows behind the shutters. They are automatically closed when breaker is removed, to prevent accidental contact.
5. Do not insert partially disassembled breakers, test breakers, ground and test devices, or other items into an energized cell. Tests using these devices must only be conducted when main bus is de-energized.
6. Never manually close a circuit breaker into a live circuit.
7. Never disconnect or open the secondary circuit of current transformers when they are on energized circuits. High voltages will develop between contacts. Keep spare current transformers shorted on their secondary circuit.
8. When circuits are opened for maintenance, repair or inspection, lock circuit breakers or disconnect switches in the open position and tag or mark to let others know that it is locked open for safety purposes. In addition, bus should be grounded to prevent accidents from accidental closure or back feeding.



## DANGER

**Do not touch the live part (conductor, terminal connecting part) while a live current is flowing.**

Electric shock can cause serious injury or death.

# SAFETY PRECAUTIONS

---

## 1. SAFETY PRECAUTIONS



### CAUTION

**1. Do not change the circuit at your own discretion.**

It may cause a malfunction or failure.

**2. Do not disassemble, change or modify the product at your own discretion.**

It may cause a short circuit or overheating, and the product quality cannot be guaranteed.

**3. Do not store the product in a place at risk of flooding & high humidity.**

It may cause insulation breakdown & deterioration of product performance.

**4. Do not store indoor switchboards outdoors.**

It may cause deterioration of product performance due to moisture, etc.

### 1.1 Handling Electrical Machinery and Apparatus

In order to prevent accidents, anyone handling electrical machinery and apparatus must be thoroughly acquainted with the precautions noted below and with those in section 2, "Electric Shock Prevention".

Most accidents can be prevented with cautions. Always observe these precautions.

#### 1.1.1 General Precautions

Observe the following precautions when performing maintenance or inspection in order to avoid electric shock or a short circuit. (Accidents can be caused by dropping metal tools, flashlights, or other conductive materials)

## 1. SAFETY PRECAUTIONS

### 1.1 Handling Electrical Machinery and Apparatus

#### **DANGER**

##### Working Preparations

Treat electrical equipment as highly flammable material at all times.

- Do not smoke or use flames in the vicinity of the equipment.
- Wear a helmet, safety shoes, and work clothes when working on the equipment.
- Cut off the power supply. Otherwise there is the danger of electric shock from live bus-bars and other current carrying parts when the switchgear or other electrical panel is opened.
- Make sure there is no voltage in the circuit before any electrical work is done, and ground the panel. Make sure the panel is grounded. (use a voltmeter/circuit tester or the like).
- Never work on the charging area. (Except in an emergency)
- Inspect the surroundings for any possible dangers, and inform your associates of what you plan to do.
- Provide sufficient lighting for the work area.
- Maintain orderly work area. Do not scatter tools.
- Learn the proper way to use a circuit tester and other necessary tools.
- Read and understand section 2, “Electric Shock Prevention”.

#### **CAUTION**

##### Inspection and Maintenance

- Daily inspection
  - Check appearance for any damage. Pay special attention for noise, bad odor, and discoloration.
- Periodic inspection
  - Check each busbar fixing section, device mounting section, and wiring section for any looseness. If any looseness is found, fasten the fixed bolts again.
  - Check appearance of each device (vacuum circuit breaker, vacuum contactor, protective relay, current & voltage transformer, fuse, module card, etc.) for any missing or damage. If any failure or damage is found, replace it with the spare parts.
  - Check each device (vacuum circuit breaker, vacuum contactor, protective relay, current & voltage transformer, fuse, module card, etc.) for noise, bad odor, or discoloration. If any noise, bad odor, or discoloration is found, replace with the spare parts.
  - Check the mechanical operating section of each device (vacuum circuit breaker, vacuum contactor, protective relay, etc.) for any mechanical malfunction in operation. If any malfunction is found, replace with the spare parts.

# SAFETY PRECAUTIONS

---

## 1.1 Handling Electrical Machinery and Apparatus

### 1. SAFETY PRECAUTIONS

#### 1.1.2 Precautions for Hot-line Work

Never perform hot-line work unless it is unavoidable. If repair of live circuits or electrical devices is unavoidable, refer to the section 2, “Electric Shock Prevention” and follow the precautions listed below.



#### Hot-line Work

Treat electrical equipment as highly flammable material at all times.

- In the presence and/or under the supervision of competent supervision, perform the work while observing the following preparatory steps.
  - Provide sufficient lighting for the work area.
  - Remove wristwatches, rings, and other metal articles from the body.
  - Wear long sleeve work clothes that fit close to the body, and make sure clothing and shoes are dry.
  - Insulate yourself from the body, and place insulating material over any devices or structural components which may be accidentally touched.
  - Cover tools with vinyl tape wherever possible.
  - When doing electrical work, cover live part with insulating material or safety shutter to protect against dropped tools and scrap-wire, and inadvertent touching of live parts.
  - Place insulation between the live section of the circuit and the section to be worked on.
  - Wear rubber gloves on both hands (and wear rubber boots).
- Work with the dominant hand as much as possible, and take care not to lose your balance. A loss of balance due to the movement of the ship can cause an accident.
- If there is emergency situation, the site manager should cut the power off immediately and report the issue to the related personnel.

## 1.1 Handling Electrical Machinery and Apparatus

# 1. SAFETY PRECAUTIONS

### 1.1.3 Guidelines for Fire Extinguishing

In the event of an electrical fire, quickly perform the following procedures.



#### Fire Extinguishing

- Cut off the power to the circuit or device from which the fire began.
- Cut off the power to other circuits or devices which may be damaged by the fire, including those which could be damaged if the fire spreads.
- Do not cut off power to any devices which could cause a serious accident if deprived of power.
- Inform your supervisor or anyone close to the area of the fire.
- Use a fire extinguisher (powder or halide type) to fight the fire.  
In a small room or section, there is the danger of asphyxiation from the fire extinguishing material, so be careful to avoid this.  
In the case of electrical fires, always cut off the power supply first.
- Be careful when using water to extinguish an electrical fire.  
The person fighting the fire could be electrocuted by current flow through the water.
- Think carefully when choosing between seawater and a fire extinguisher.  
Once electrical devices have come in contact with seawater it is difficult to restore them to their original condition.  
In some cases, a fire extinguisher is the best choice even if it requires more time than seawater to put out the fire.

### 1.1.4 Maintenance and Inspection of VCB



#### Maintenance of VCB

See the operating instructions of the particular breaker for correct maintenance, inspection, and replacement procedures.

For some types and mounting configurations, the entire switchgear must be cut off from the work for [Fixed type].  
For others, only a restricted area of the switchgear must be cut off for [Draw-out type].

# SAFETY PRECAUTIONS

---

## 1.1 Handling Electrical Machinery and Apparatus

### 1. SAFETY PRECAUTIONS

#### 1.1.5 Precautions for VCB Operation

#### **DANGER**

##### VCB Operation

- Before operating circuit breakers switches, confirm the following to avoid putting others in danger.
  - There will be no problems if any or all devices in the circuit receive power.
  - There are no other workers working on the same circuit.  
If there are other workers working on the same circuit, inform them of what breaker or switch you will be operating and advise their caution.
  - The protective devices (protective relay, fuses, etc.) of all circuits are in order.
- Operate breakers and switches in the following manner.
  - Perform all operations with the dominant hand.  
keep the other hand back and away from the breaker or switch except for operations that require both hands.
  - Operate knife switches with one quick motion.

#### 1.1.6 Precautions for Current & Voltage transformer Operati

#### **CAUTION**

##### CT & VT Operation

Do not open the secondary side of a current transformer.

If the secondary side must be opened for repair work, do not leave it opened; high voltage could be produced in the secondary side as current flows through the primary side. Periodically check the connections of the secondary side for tightness.

## 1. SAFETY PRECAUTIONS

### 1.1 Handling Electrical Machinery and Apparatus

#### 1.1.7 Precautions for Changing Fuses

##### **DANGER**

##### Changing Fuses

- Changing fuses
  - When removing a fuse, unscrew the fuse cap carefully.
  - While inserting the fuse into the fuse clip, do not allow the conductive part of the fuse to touch the gap between fuse clips. Otherwise, a short-circuit accident could arise!
  - When changing a fuse, do not make contact with charged devices or with any other live parts nearby, (i.e. bus-line etc.). Otherwise, electric shock could arise!
- Selecting the right spare
  - Use a spare of the same type and rated current as the blown fuse.

#### 1.1.8 Other Precautions

##### **CAUTION**

##### Other Precautions

- Keep front doors and back covers or doors closed except when it is necessary to open them.
- Before starting electrical work, immobilize the moving parts by fastening the door or any objects that can move the cover of the switchgear.
- Do not remove protective plates or protective covers. If they must be removed, keep them to their proper positions.
- Do not leave any tools or work materials on or around the switchboard or starter panel after work is completed.
- Always discharge capacitors before working on capacitor circuits.

# SAFETY PRECAUTIONS

## 1. SAFETY PRECAUTIONS

### 1.2 Electrical Shock Prevention

#### 1.2.1 General Information on Electric Shock

- The Danger of Electricity
  - Receiving an electric shock is extremely dangerous.  
Even a relatively small amount of current can be fatal if it passes through the head, lungs, or other vital organs.
  - 220V AC is more dangerous than we think.
  - At 220V AC, 60/50 Hz, even 50milliamperes (mA) is dangerous and 50~100mA can cause a fatal electric shock.
- The Symptoms of Electric Shock

The symptoms described below must be treated immediately with artificial respiration or Cardiopulmonary Resuscitation (CPR) until the victim recovers. These are symptoms of electric shock and should not be confused with death. It is usual for a person suffering from these symptoms to recover even after several hours of artificial respiration or cardiopulmonary resuscitation (CPR).

The Symptoms are listed in order from mild to most serious case.

  - Breathing stops.
  - Normal breathing can usually be restored after continuing artificial respiration for a short while.
  - Breathing stops, face is pallid, and pulse is very weak or undetectable.
  - Totally unconscious.

In the worst of cases, the body of the victim may become rigid within two or three minutes after the shock.

#### 1.2.2 Prevention of Electric Shock

Anyone who is operating or performing maintenance or repairs on electrical equipment or anyone who supervises people doing such work should take the following measures to prevent electric shock accidents.



#### Prevention of Electric Shock

- Never estimate the voltage applied to the circuit until the voltage has been confirmed (measured).
- Always cut off the power supply and confirm that there is no voltage applied to the circuit before any electrical work is done. Most accidents occur because the power is mistakenly assumed to be off.
- Always use rubber gloves, rubber boots, and an insulation mat when doing electrical work.
- Tag the power supply switch when doing electrical work.  
(ex. "Do Not Turn on Power: Maintenance Work")
- If someone turns on the power during maintenance may cause serious accident.
- Operate switches with the dominant hand while holding the other hand at the back away from the body.
- The site manager should be available near the Switchgear installed area, so that they can cut off the power immediately if an accident occurs.

## 2. SWITCHGEAR DESCRIPTION

This instruction manual describes general and basic matters required for packing, storage, installation, operation, and inspection of the product to secure safety of operator and optimal operation of the product.

The manual shall be known well in parallel with relevant drawings and documents provided additionally.

Metal-clad switchgear is a form of protection for power distribution systems.

Properly designed switchgear will limit the extent of outages, prevent serious fault current damage, and protect lives and property all at a reasonable cost.

The major elements in metal-clad switchgear are the circuit breakers, bus and cable, relays, control equipment, and the metal-clad structure itself.

All elements have different functions but their combined purpose is to deliver power with minimum outages while at the same time reacting quickly to interrupt short circuit currents before serious damage can occur to other devices.

Circuit breakers are the actual circuit interruption devices. In a typical system each feeder will have a separate circuit breaker while each incoming line will also have a breaker. These are designed to limit the fault current through them while normal currents flow at the same time.

Bus and cables are the actual method of power distribution because current flows through them, and they are insulated from the ground.

Relays are the sensors of the system. They react to voltage, current, frequency, or other system conditions. When those conditions match predetermined levels the relays will initiate tripping of the appropriate breakers.

Control equipment is used to check or control system parameters. Lights indicate if breakers are open or closed. Control switches will open or close breakers, enable or disable relays or devices, and determine operational modes [i.e. remote or manual or automatic.].

Meters will show voltage, currents, frequencies, or other relevant parameters.

The structure of the switchgear serves multiple functions. It protects all the elements from damage or environmental influences. It protects humans from harmful voltages or energies which may cause potentially electric injury. It also isolates sections of the switchgear from each other.

Finally, it supports the various devices and provides a mounting position for them.

The equipment is designed for liquid exposure; however, liquid can potentially destroy the integrity of the insulation and therefore should be avoided.

# SWITCHGEAR DESCRIPTION

## 2. SWITCHGEAR DESCRIPTION

### 2.1 Panel description

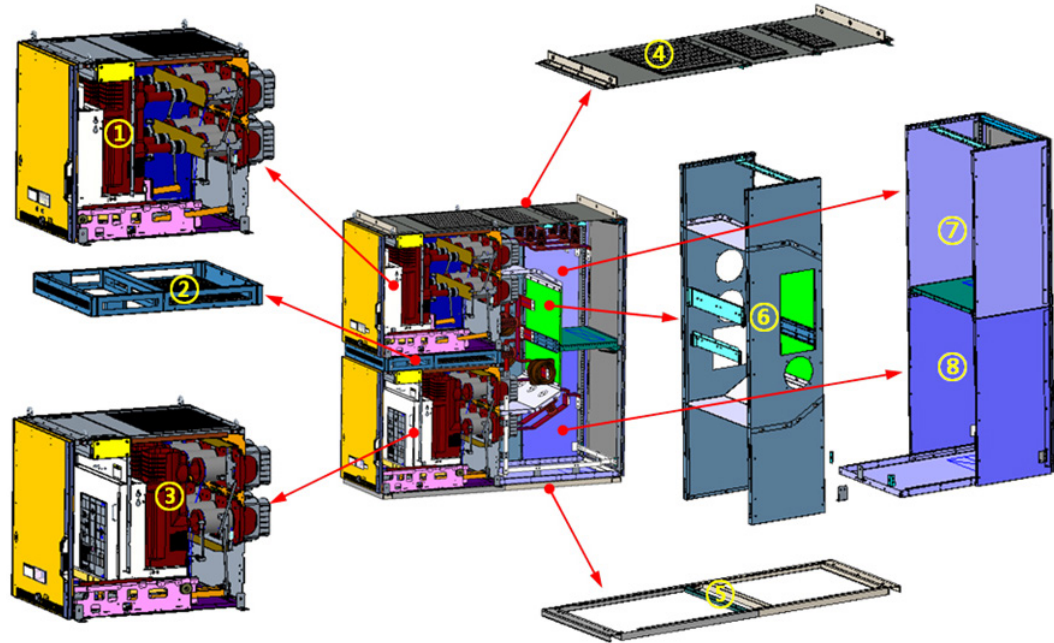

< Fig. 2.1 >

- |                            |                            |
|----------------------------|----------------------------|
| 1. Upper CB compartment    | 2. Frame support           |
| 3. Lower CB compartment    | 4. Top cover               |
| 5. Channel base            | 6. Bus compartment         |
| 7. Upper cable compartment | 8. Lower cable compartment |

### 2.1.1 Single line diagram for each section

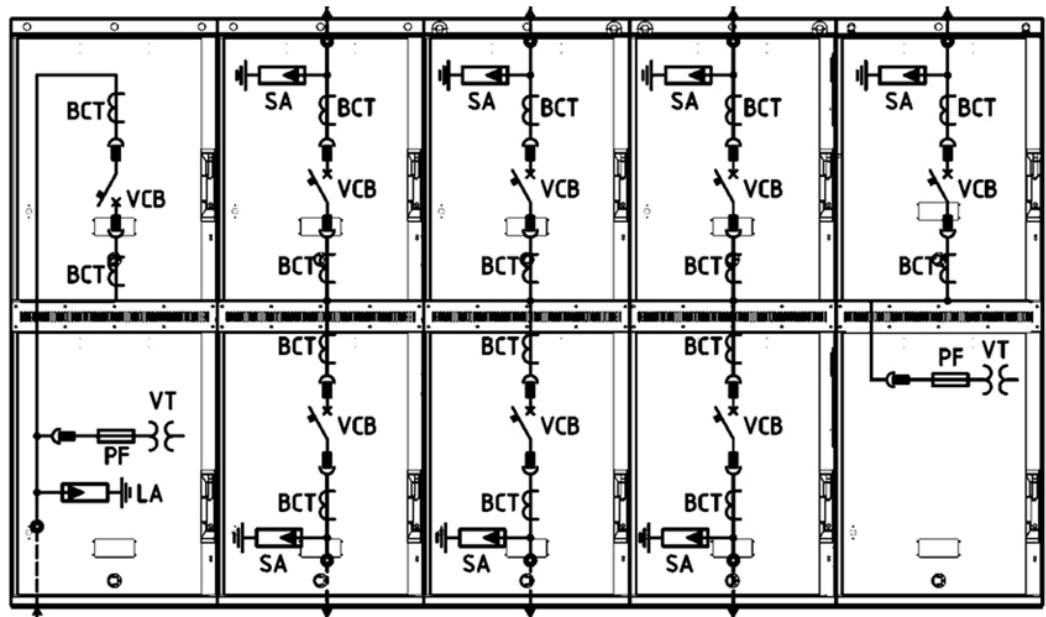

## 2. SWITCHGEAR DESCRIPTION

### 2.2 Applied standards

Designation	IEEE standard
Switchgear	IEEE Std C37.20.2 2015
AC High-Voltage Circuit Breakers	IEEE Std C37.09 2018
Ground & Testing Device	IEEE Std C37.20.6 2015
Current transformer	IEEE Std C57.13 2016
Voltage transformer	IEEE Std C57.13 2016

### 2.3 Environmental and operating conditions

Ambient conditions in accordance with IEEE C37.20.2	
Min./max. ambient temperature	-22°F and +104°F(-30°C /+40°C)
Installation altitude above sea-level	≤ 3300ft (1000m)
The effect of solar radiation is not significant.	

\* Note. If under unusual service conditions, please check with the manufacturer (LS ELECTRIC).

### 2.4 Technical data

Technical data	
Rated voltage Ur [kV]	27
Rated lightning impulse withstand voltage Up [kV]	125
Rated power frequency withstand voltage Ud [kV]	60
Rated normal current, Horizontal(main) busbar Ir [A]	≤ 1200A or 2000A or 2500A
Rated normal current, Vertical (Distribution) busbar Ir [A]	≤ 1200A or 2000A or 2500A
Rated short-time current Ik of busbar [kA]	≤ 31.5 or 40 (3s)
Rated frequency [Hz]	60

### 2.5 Name plate

The nameplate on the panel specifies essential technical data. They are mounted on the cover of the switching device compartment and in the switching device compartment.

The following data on the nameplate are relevant in case of any queries:

- Type designation
- Serial number
- Manufacture Date

#### [Sample nameplate]

METAL-CLAD SWITCHGEAR		OVER 1000 VOLTS
TYPE	SOLUTION POWER S27 UL	
MANUFACTURER'S NAME	LS ELECTRIC Co., Ltd.	
MANUFACTURER FACTORY ID	LS ELECTRIC	
MANUFACTURER'S ADDRESS	95 BAEKBONG-RO HEUNGDEOK-GU CHEONGJU-SI CHUNGCHEONGBUK-DO 361-720 KOREA	
RATED MAXIMUM VOLTAGE	27 kV	
RATED FREQUENCY	60 Hz	
LOW FREQUENCY WITHSTAND VOLTAGE	60 kV	
IMPULSE WITHSTAND VOLTAGE	125 kV	
RATED CONTINUOUS CURRENT	1200 A	
RATED SHORT TIME CURRENT	31.5 kA	
RATED MOMENTARY CURRENT	81.9 kA	
VERTICAL SECTION OF A LINEUP	X OF X	
DATE OF MANUFACTURE	2022.12	
<div style="border: 1px solid black; padding: 2px; display: inline-block;">UL Listed Sticker</div>		
		
MADE IN KOREA		

# SWITCHGEAR DESCRIPTION

## 2. SWITCHGEAR DESCRIPTION

### 2.6 Dimensions and weight

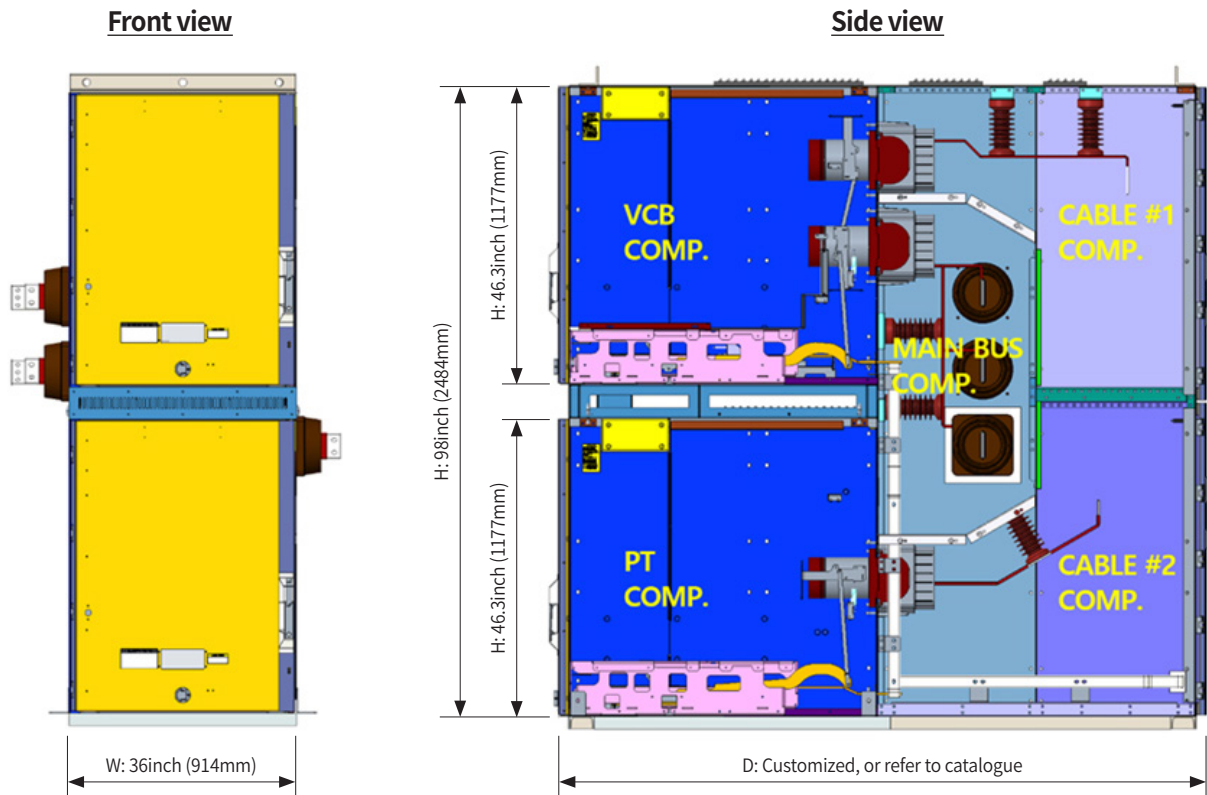

< 1200A SWGR >

#### Maximum weight ( $\leq 2700\text{kg}$ )

- With vacuum circuit breaker
- The busbars have been taken into consideration with a maximum weight at 1200A
- Without electric device in VCB comp.
- Without packing
- With PT (1-High PT Compartment)

## 2. SWITCHGEAR DESCRIPTION

### 2.6 Dimensions and weight

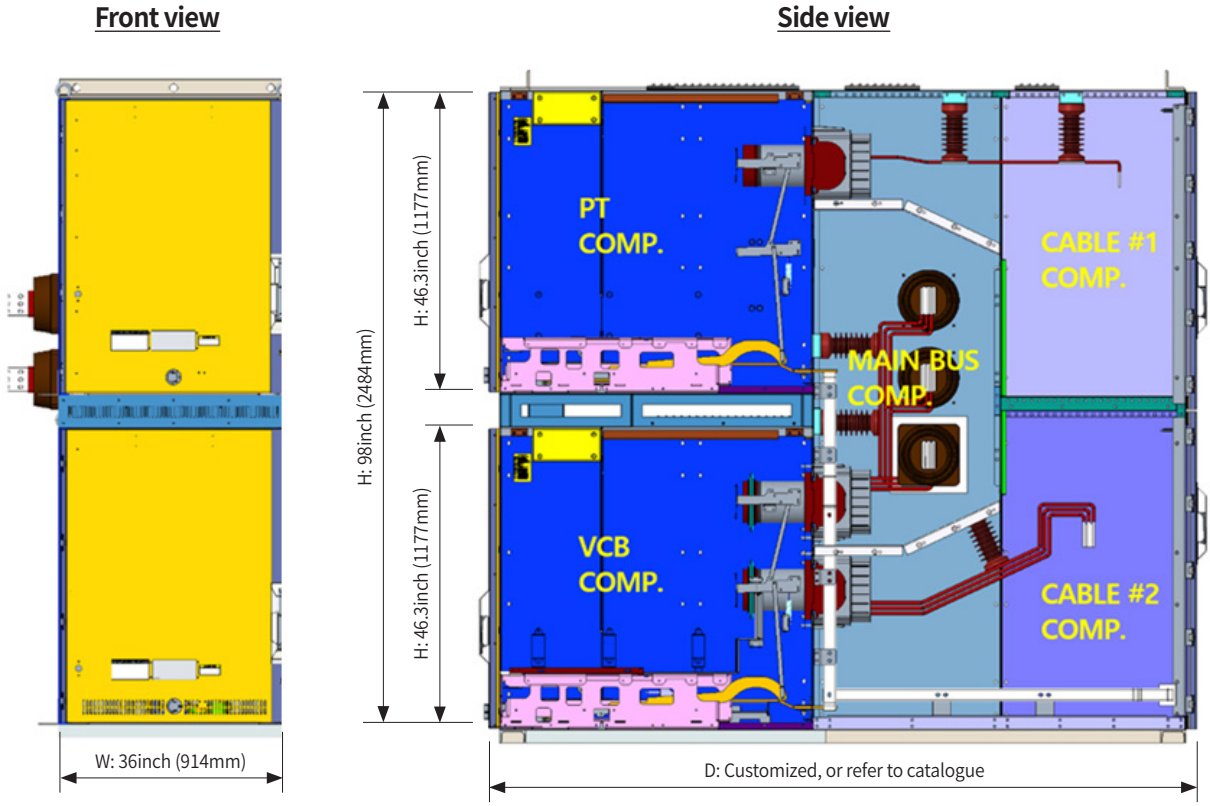

< 2500A SWGR >

**Maximum weight (≤3000kg)**

- With vacuum circuit breaker
- Without packing
- The bus bars have been taken into consideration with a maximum weight at 2500A
- Without electric device in VCB comp.
- With PT (1-High PT Compartment)

# SWITCHGEAR DESCRIPTION

## 2. SWITCHGEAR DESCRIPTION

### 2.6 Dimensions and weight

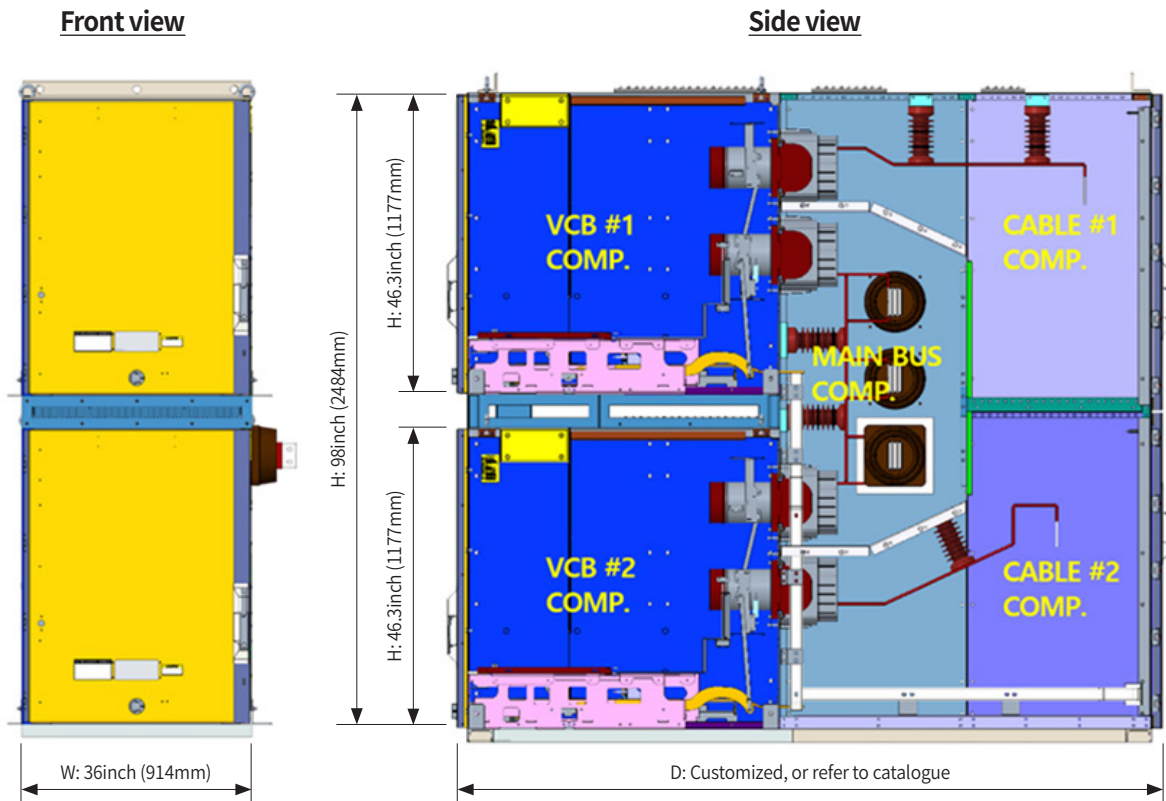

< 1200/1200A SWGR >

#### Maximum weight ( $\leq 3000\text{kg}$ )

- With vacuum circuit breaker
- Without packing
- The bus bars have been taken into consideration with a maximum weight at 1200/1200A
- Without electric device in VCB comp.
- With PT (1-High PT Compartment)

## 2. SWITCHGEAR DESCRIPTION

### 2.7 Intended use

Susol UL medium-voltage switchgear units are exclusively intended for switching and distributing electrical energies. They may only be used in the scope of the specified standards and the switchgear-specific technical data. Any other utilization constitutes improper use and may result in dangers and damage.

#### Liability Disclaimers

The manufacturer shall not be held responsible for damage which occurs if:

- Instructions in this manual are not complied with;
- The switchgear is not operated according to its intended use (see above);
- The switchgear is assembled, connected or operated improperly;
- Accessories or spare parts that were used are not approved by the manufacturer;
- The switchgear is converted without the manufacturer's approval, or if inadmissible parts are added. No liability is accepted for parts provided by customers, e. g. power cables.

### 2.8 Disposal after the end of service life

Upon request, a material and recycling data sheet is available for disposal of Susol UL Medium-Voltage Switchgear at the end of its service life.

Disposal is performed as a service by the manufacturer's service center and is subject to a fee.

## 3. PACKING

The water proof papers are placed in the bottom.

The silica gel bags are put in each unit and enclosure in order to keep them dry. e.g. approx. 10kg per panel.

Note the warning and caution signs/labels printed on the crate. Lifting angles are bolted on the top of the MV Switchgear. Use them to lift and transfer the crate in accordance with lifting marks on the crate before the unpacking.

It is recommended that MV Switchgear is moved, without being unpacked, to the place where it will be installed. To move the MV Switchgear after the unpacking, use rolls of small diameter if a crane is not available.

During transportation, special care is required to make sure that the Switchgear does not fall.

The packing method changes in particular cases. Example: Long-term storage.

## 4. RECEIVING, HANDLING & STORAGE

Before switchgear is shipped, it is assembled as much as possible, then dispatched to the port.

Hardware, small parts, and brackets are boxed and shipped with the switchgear assemblies. Breakers, batteries, and other major components are usually shipped in their own cartons. Cartons, crates, and boxes are tagged to ease the receiving and assembly.

### 4.1 Receiving

Once switchgear arrives, inspect the equipment for any damage. If there is any shipping damage a claim should be filed with the shipping company. Please notify a manufacturer representative as soon as possible.

Carefully look at the packing list to assure all parts have arrived. Note that small items may be packed with larger ones; this will be noted on the shipping documentation.

### 4.2 Handling



#### WARNING

Make sure the rope or chain is strong enough to bear the weight of the panel. Comply with the relevant provisions for hoisting equipment.



#### WARNING

On lowering the panels, make sure that the supporting platform is sufficiently stable and even.



#### WARNING

Risk of accidents. Pay attention to floor openings!

Before handling, refer to the drawings for approximate weight of shipping sections. Care should be taken to avoid damaging the switchgear during handling operations. Use rated equipment only for lifting the weights involved, and skilled crews with heavy lifting of large electrical equipment.

Prior to uncrating, the equipment may be moved by a crane using slings under the crate. Rollers under crate skids would also be an acceptable method of moving the switchgear section.

# RECEIVING, HANDLING & STORAGE

## 4. RECEIVING, HANDLING & STORAGE

### 4.2 Handling

After uncrating the switchgear shipping sections should be moved by cranes using chain and spreader bars. Breakers generally have their own lifting eyes.

Dragging or skidding switchgear along the ground may damage foundations. Accordingly, there could be damage to the exterior and functions.

Improper lifting or failure to use spreader bars may cause damage to the enclosure by applying a compressive lateral force. Improperly rated lifting equipment or untrained crews may drop switchgear which causes breakage, warpage and misalignment.

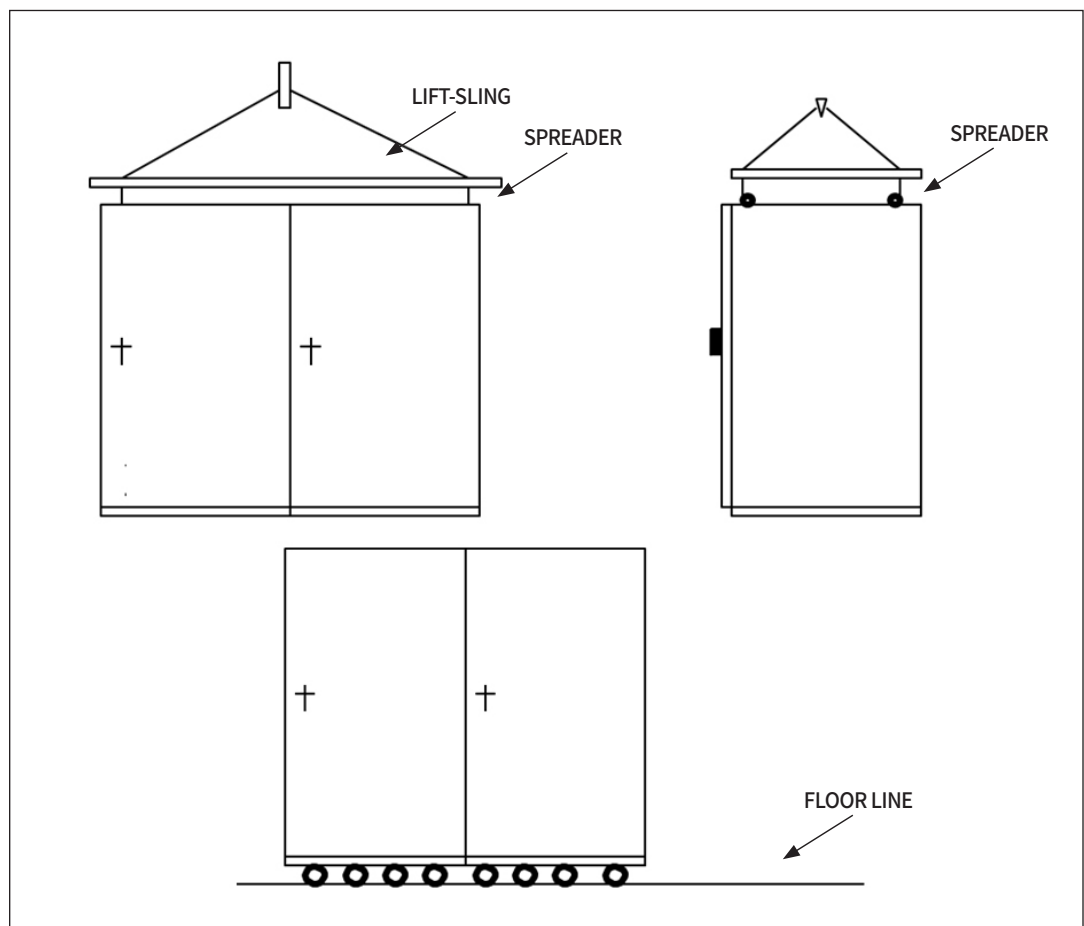

< Fig. 4.2. Recommended Method of In-door Equipment >

(For movement in this direction only, use rollers)

(Rollers must support the front, middle, and rear floor channels)

## 4. RECEIVING, HANDLING & STORAGE

### 4.2 Handling

#### Transportation of panel by means of a crane

- Attach the crane straps in the four holes on top of the panel using shackles and slip hooks (Fig. 4.2.1), and make sure to leave a minimum height of 1 m (Fig. 4.2.2).
- Release the front and rear panel screw fastening from the transport packaging. To this effect, remove the cable compartment cover.
- Carefully lift the panel and deposit it at the intended location.

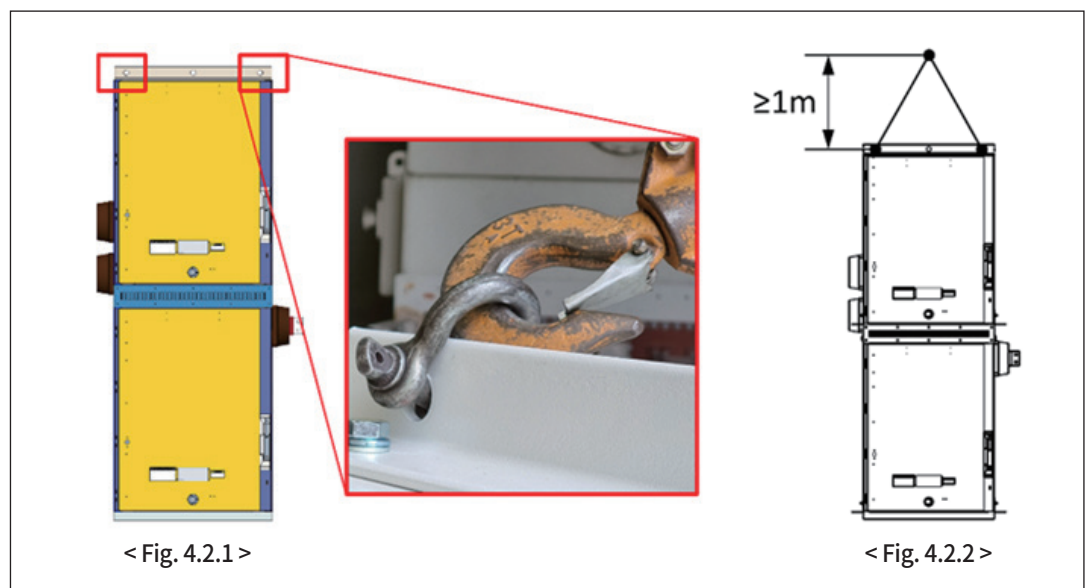

### 4.3 Storage

#### 4.3.1 Storage method

If the equipment is to be stored for a lengthy period of time, it should be prepared for storage and stored under the following conditions.

DO NOT Uncrate wooden box of the switchgear.

Choose a clean dry location free from harmful vapors. Switchgear should be stored on a flat floor to prevent bending and structure twisting. Do not store directly on the dirt or mud. Some covering should be on the ground under the switchgear. Cover with heavy traps to keep dust and dirt from settling in. Allow adequate ventilation to remove condensation.

If dampness or condensation is encountered, heaters should be placed to prevent damage. Remove any plastic, paper, cardboard, or fabric from the vicinity of the heaters. Never use heaters around flammable liquids or gasses.

If severe weather conditions are encountered, (e.g. heavy snow, rains, strong winds), switchgear should be stored inside the shelter of a building.

If the equipment must be stored for more than three months from the shipment date, it should be placed in a dry, clean, well-ventilated, and heated indoor environment. After 12 months from the shipment date, it is recommended to uncrate the equipment for a visual inspection under the manufacturer's supervision, and then repack it.

Batteries and breakers should be stored under the requirements of their respective instruction manual. In general, those requirements are more stringent than switchgear requirements.

# RECEIVING, HANDLING & STORAGE

## 4. RECEIVING, HANDLING & STORAGE

### 4.3 Storage

#### 4.3.2 Check point for storage

- Wooden condition
- Vacuum bag condition
- Humidity in vacuum bag
- SWGR condition







### 4.4 Storage guarantee

The quality guarantee for the panels lasts for 2 weeks after unpacking when stored indoors in a well-ventilated area. The storage area should have a well-drained, paved floor, and the temperature should be above 60°F with air humidity not exceeding 60%. After the guarantee period has expired, the manager must repack the panels.



### WARNING

Do not walk on the roof of the panels (rupture point in pressure relief devices). The pressure relief devices could be damaged. (If provided)

NO	DESCRIPTION	MARK	POSITION
1	THIS WAY UP		SIDE
2	FRAGILE		-
3	KEEP DRY		-
4	DO NOT USE HOOK DO NOT PUNCTURE		FRONT
5	SLING HERE		-
6	DO NOT TUMBLE DO NOT DROP		-
7	CENTER OF GRAVITY		-

## 5. INSTALLATION

### 5.1 Installation



#### WARNING

**1. Tighten bolts and screws with specified torque.**

It may cause overheating and ignite a fire.

**2. Do not use bolts longer than the specified length.**

It may cause a short circuit and ignite a fire.

**3. Remove foreign matter/ objects (tools, wires, bolts, washers) after an installation.**

It may cause a short circuit and ignite a fire.

**4. Do not wipe the surface of the running product with a wet cloth after completing an installation, inspection or maintenance.**

It may cause an electric shock.



#### CAUTION

**1. Do not change the circuit at your own discretion.**

It may cause a malfunction or failure.

**2. Do not disassemble, change or modify the product at your own discretion.**

It may cause a short circuit or overheating, and the product quality cannot be guaranteed.

#### 1) Installation site

Check the floor, column, wall and switchboard layout schematics of the installation site.

#### 2) Floor cleaning

Check the level of the installation surface, and grind the severely uneven parts to make its surface horizontal and clean the installation surface.

#### 3) Installation of switchboard

Install the switchboard according to the order shown on the outside view, while taking caution to not damage operation switches, indicators, meters, and devices protruding from the surface of the switchboard.

Connect the panels, clean the inside and outside of the switchboard, and check for any damage or breakage during an installation.

# INSTALLATION

## 5. INSTALLATION

### 5.1 Installation

#### 4) Adjustment of the liner

Adjust the height using a liner, ensuring the channel base is perfectly aligned with the horizontal surface. Measure the height at 1m intervals using a spirit level.

Install the liner to be aligned with the outer part of the channel base as much as possible, and affix it using a kind of mortar that does not shrink.

It is recommended to install the liner around the anchor bolts at wide intervals in the center of the channel base.

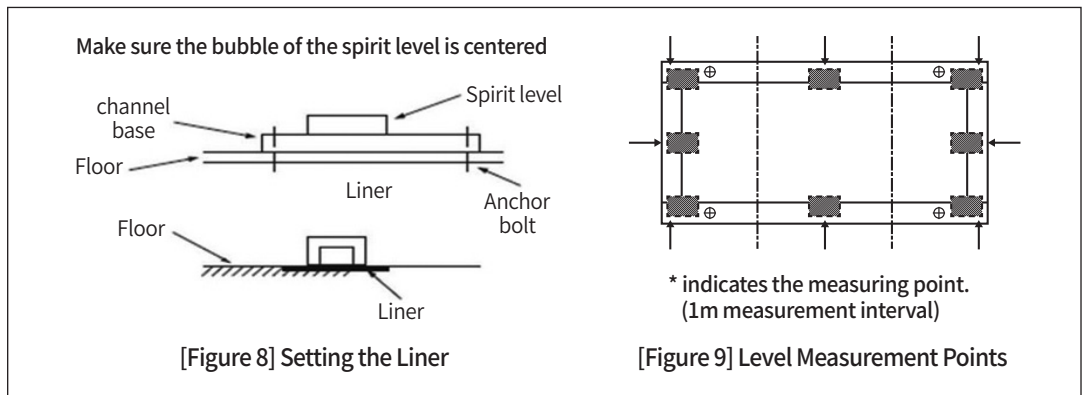

#### 5) Installation of anchor bolts

Drill a hole in the anchor bolt hole of the channel base, and completely affix it with the prepared anchor bolt.

The liner must be set first before installing the anchor bolt. Refer to the diagrams for the bolt dimension and details.

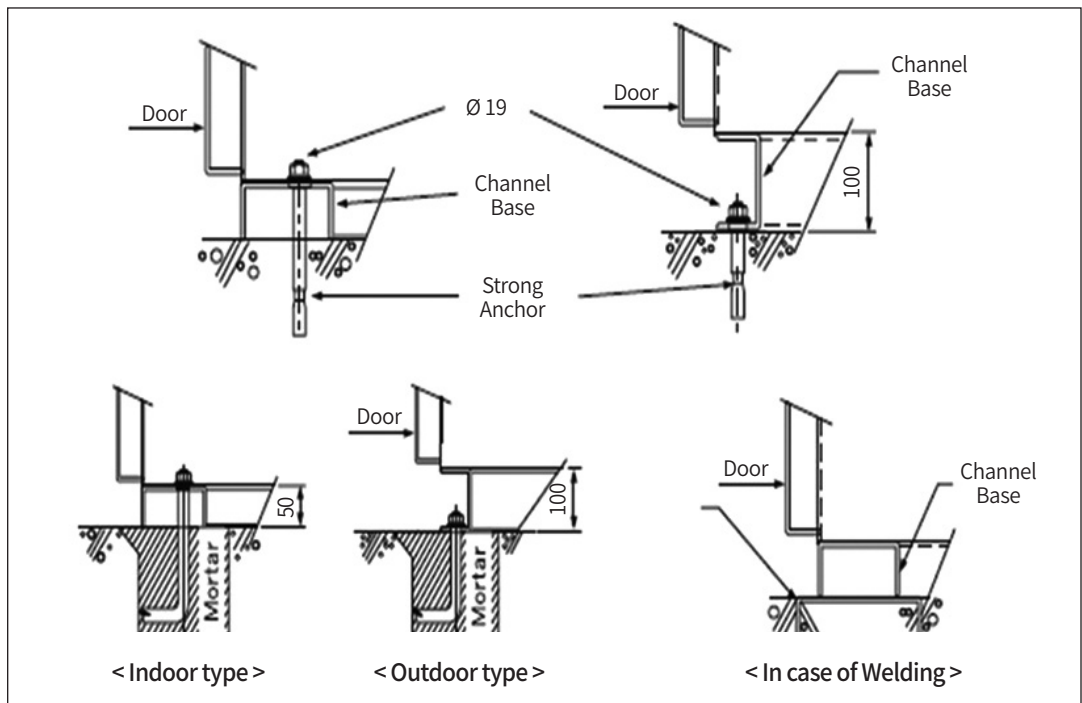

## 5. INSTALLATION

### 5.1 Installation

For installation at site, the switch-room must be completely set up. There should also be lights, power supplies, locking devices, and ventilation systems should be available.

The electric room should be well-ventilated. Avoid high temperatures and humidity. It should be well-ventilated and avoid high temperature, and humid area. Even when humidity is relatively low condensation can occur if there is significant temperature change. An air conditioner or dehumidifier should be present at the site if this occurs.

It is recommended to install MV switchgear at a place where salt, explosives, or toxic gas are avoided. It should be installed in a place where there is no flooding and or water-drops occur. Especially, take a special care to not cause the accidents due to water leakage from the upper floor. Do not install combustible gas, water, or fuel pipes in the power substation.

Power cables and control cables which are to be connected to the switchgear should be prepared in advance. Where switchgear panels have top-mounted structures for earthing switches or instrument transformers, it must be ensured ensure that ceiling height is sufficient to open plates.

### 5.2 Foundations

Before placing the switchgear, the foundation must be settled. The mounting area of the switchgear should be within 0~2mm. Adjustments are made by using a steel plate or by installing steel plates under the corners and center of cubicles if needed.

Unleveled foundation may cause improper operation of doors and voltage transformer cabinets. Weatherproof seals may not align correctly.

Breakers may not rack in and out. Section alignment and busbar connections would be much more difficult. Unleveled areas in front of indoor sections may interfere with door opening, VCB operating and voltage transformer racking in-out.

# INSTALLATION

## 5. INSTALLATION

### 5.2 Foundations

For switchgear installation, it is recommended that there are no protuberances [i.e. conduits, wiring, ground connectors] above the level of the concrete. This will prevent problems when the switchgear is placed.] All concrete preparation work should be done prior to placing any switchgear. This includes leveling, drilling holes and finishing.

In addition to the physical problems of doing concrete work after placing the switchgear, concrete work will generate dust which is harmful for switchgear.

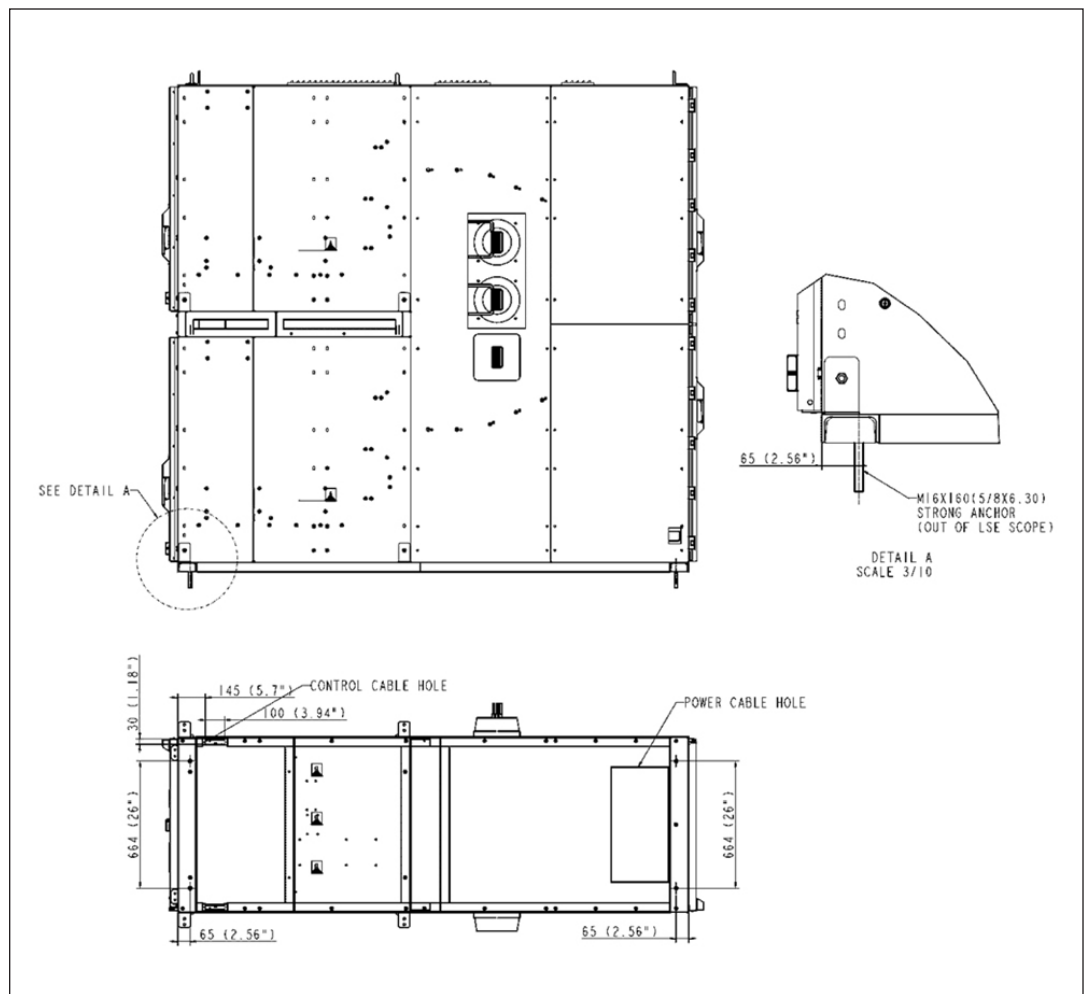

< Fig. 5.2.1 Foundation of Indoor Equipment >

## 5. INSTALLATION

### 5.2 Foundations

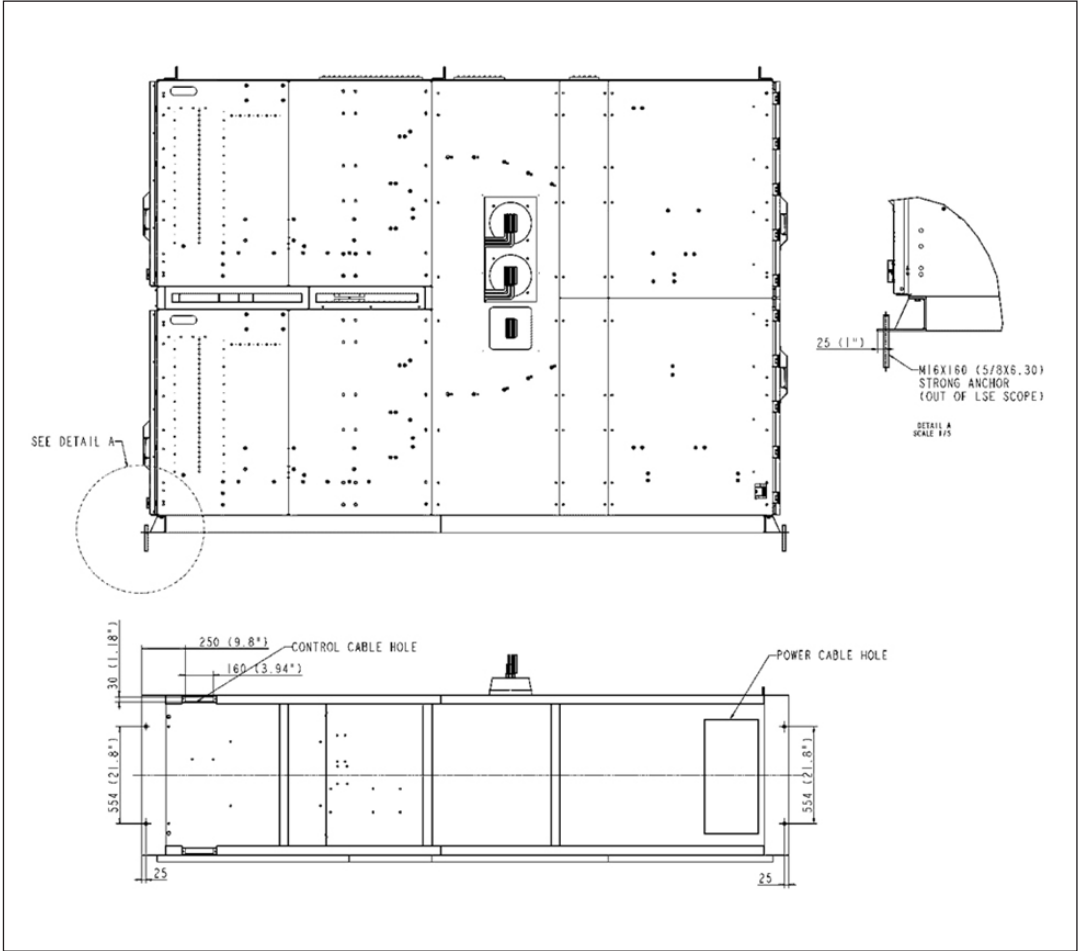

< Fig. 5.2.2 Foundation of Indoor Equipment >

### 5.3 Placement

Prior to placing switchgear on the foundation, all packing and crating material should be removed. If it exceeds 2 sections or more, the center section should be placed first. Switchgear sections should be placed before aisle section.

Align the first section of switchgear. It is important that the other sections will be exactly aligned in case the first section correctly placed. Install on each side from the center section. Each section should be aligned when placed.

After the switchgear is placed; check the flatness and vertical level. When it is out of level, shims should be inserted at the point where the switchgear is fastened to the foundation.

Remove all temporary bracing and shipping supports. These items have been painted in different colors to aid in identification.

# ASSEMBLY OF THE MCSG

## 6. ASSEMBLY OF THE MCSG

### 6.1 Safety provisions

The switchgear panels may only be installed and assembled by the manufacturer's staff or by persons who are qualified.

### 6.2 Important instructions for assembly

#### IMPORTANT

- Condensation, dirt, and dust during assembly should be avoided on all accounts, in order to prevent damage on the panels.
- For assembly, observe the assembly drawings supplied with the equipment. Read them before you commence assembly work.
- For all screw/bolt connections, refer to the tightening torques specified in Table A on page 23~24.
- For assembly of switchgear-specific equipment (e.g. sidewalls, deflectors, pressure relief ducts, etc.), refer to the specific manual provided separately (if applicable).

### 6.3 Assembly

#### 6.3.1 Indoor Assembly

After the switchgear has been aligned and leveled, it must be bolted together. Loosely attach each section to others. This will allow any last minute shimming to facilitate assembly. Tighten all bolts to firmly secure sections together. When assembly has been completed, anchor switchgear to foundation. Anchor locations are shown on the construction drawing.

#### 6.3.2 Main BUS connection Between Sections

Main bus connections are made between sections by bolting each main bus. When the bus is aligned with allowing busbars in adjacent cubicles, they are jointed directly to each other by using bolts. When this is not possible, links are provided for bus connections.

Clean contact surface with nonflammable, non-harmful cleaning solution, and wipe off with nonabrasive cloth. Bolt bus sections together. Attach the boots if provided.

\* To prevent distortion of the main bus, if delivery bracket is installed, remove the bracket before connecting the main bus between sections.

\* All bolted bus should be made up using the proper torque value as shown in table A.

## 6. ASSEMBLY OF THE MCSG

### 6.3 Assembly

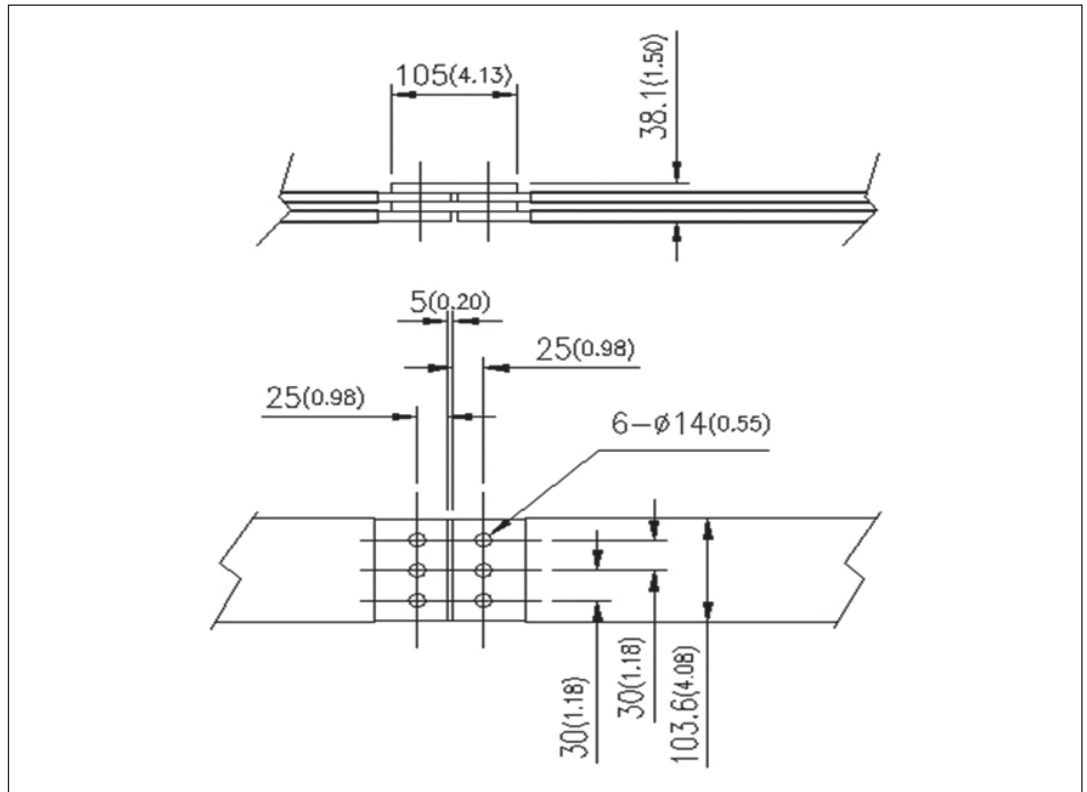

< Fig. 6.3.2 Main Bus Connection >

< Table A > Torque values for switchgear hardware

Category	Torque (kg · f · cm)
Bolted bus connections	M8 : 200~245 M10 : 350~490 M12 : 600~850
Power Cable connections	M6 : 70~100 M8 : 200~245 M10 : 350~490 M12 : 600~850 M16 : 1500~2040
Insulators	M8 : 160~200 M10 : 300~360 M12 : 400~460 3/8"-16UNC : 230~280
Bushings	M10 : 300~360 M12 : 400~460
CT case	M12 : 400~460
CT 2'nd terminal	M5 : 30~40

# ASSEMBLY OF THE MCSG

## 6. ASSEMBLY OF THE MCSG

### 6.3 Assembly

Train the cables in the proper path to the terminals, using temporary clamping device if required, and cut to the proper length. Strip the insulation to the desired dimension, being careful not to damage any strands.

Both the cable terminals connect to the ends of the bars in the rear compartment. A non-oxidizing lubricant can be used at these connection surfaces.

Clamp the cable permanently to the cable supports.



### CAUTION

- If there are some parts to block the function during assembly, release the blocking after assembly.
- Make a final inspection to check that there are no tools, construction materials, or other foreign matter left in the switchgear.

#### 6.3.3 Control Wiring Interconnection

This switchgear has been designed to facilitate interconnection. The side of each shipping section wall is interconnected with terminal blocks. Pre-labeled wires are coiled at one set of blocks to run on the other side of the shipping split. Refer to wiring and schematic drawings for particulars on actual wiring.

#### 6.3.4 Ground bus

Ground bus is installed at the bottom of the switchgear in each section. Jumpers are provided to connect each sections of ground bus together. All grounds in the switchgear will be tied completely together. When the ground cable connects to a ground terminal, the mounting bolt is torque standard in “Table A” for the extent of bolt fastening.

#### 6.3.5 Current Transformers

Current transformer’s secondary circuit must be shorted. After the installation, the shorted secondary circuit should be removed.

#### ※ Note!

If spare current transformers are in the system with no loads, leave shorted to avoid developing high voltage across secondary terminals. Never leave when the secondary of current transformers is opened.

## 6. ASSEMBLY OF THE MCSG

### 6.3 Assembly

#### 6.3.6 Fuse

Power fuses used as isolating devices, voltage transformer protection, or high side control power transformer protection are taped in place prior to shipment. Remove the tape and lift fuses to make sure they are removable.

#### 6.3.7 Key Interlocks (If provided)

Key interlocks are used as a safety system in some switchgear. During assembly extra keys may be available to facilitate the installation. It is the responsibility of the customer to control and distribute keys. After installation, all keys should be collected and kept securely. Extra keys should be safely stored or destroyed to prevent accidents.

#### 6.3.8 Primary Cables Connection

In case of connecting primary cables to terminal or busbar, the followings should be observed;

- Before connecting the incoming cable, open the primary circuit breaker first.
- Open the door for incoming cable, and then pull the incoming cable all the way up to the bus terminal of the circuit breaker.
- Considering diameter and number of the incoming cable, make a hole for cable entrance. In case of using cable gland, perforate a penetrated hole based on outer diameter of the gland.
- Within the panel, the length of the incoming cable shall be adjusted in consideration of the extent of wire bending radius. In case of bending the incoming cable vertically at the lower part of the panel, pay attention not to destroy insulation of the cable.
- Penetrate the incoming cable through the perforated cover plate and fix it.
- At the connection of the cable to the terminal, refer to the mounting bolt torque standard in “Table A” for the extent of bolt fastening.
- When connecting the power cable, it is recommended to treat the ending part with termination kit (RAYCHEM, 3M or equivalent). Refer to the following figure for the distance of the ending part;

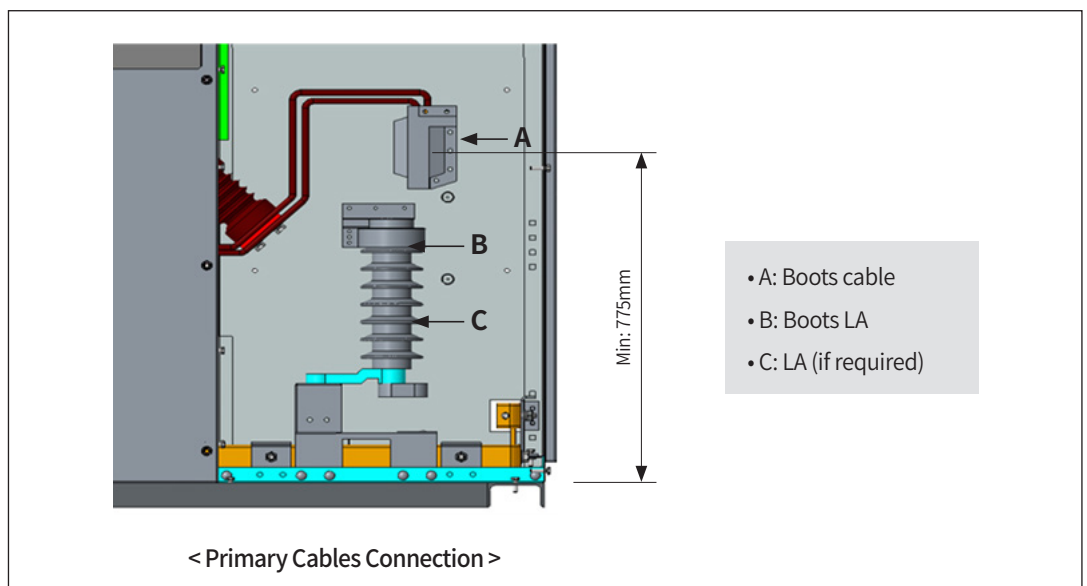

< Fig. 6.3.8 >

# ASSEMBLY OF THE MCSG

---

## 6. ASSEMBLY OF THE MCSG

### 6.3 Assembly

#### 6.3.9 Bus Duct Connections

Bus duct connections to the switchgear are brought directly into cubicles. The connection point of the duct is either directly attached to the switchgear, or attached through an expansion joint. The bus itself is joined to the switchgear through a flexible connector. The joint is insulated either with a boot or tape.

#### 6.3.10 Connection of Control Cable

Terminal block for control cable pulled from outside should use 15A or 30A to compensate decrease of line voltage since its cross-sectional area is greater than that of the control cable in the switchgear.

At the connection of incoming cable, perform wiring work referring to related drawings(circuit diagram or wiring diagram).

#### 6.3.11 Cleaning

The switchgear should be thoroughly cleaned to prevent problems later on. All garbage, paper, loose parts, etc. should be removed from the switchgear. It is recommended that the gear is vacuumed out to remove dust and dirt. Wipe down main bus insulation with clean rags.

Do not use paint thinner, lacquer thinner or aromatic solvents such as Benzene, Xylene, Trichlor, Triclene, MEK, MIBK, Toluol Benzol, Acetone, or Carbon Tetrachloride, as these will interfere with the insulation.

Acceptable cleaning fluids include Freon TF, denatured alcohol, Isopropyl or VM & P Naphtha.

#### 6.3.12 Pre-operational Testing and Inspections

During factory testing the switchgear underwent complete functional testing of the control and metering circuits, megger, and high potential testing of the main bus and an inspection to assure it was correct and complete. When the equipment is assembled in the field, it is important to conduct tests to assure that the switchgear has been correctly reassembled.

#### 6.3.13 Primary circuits

It is recommended to measure the primary bus with a megger test before energizing. A minimum of 100 megaohms should be measured to ground and phase to phase. It may be necessary to disconnect voltage transformer fuses as voltage transformers are usually tied together in a delta or wye.

High potential testing is not required but if desired it should be followed according to IEEE standards. Potential and control power transformers must be disconnected during this test. Circuit breakers should be measured megger test prior to energization. Phase to phase and phase to ground insulation resistance must be at least 200 megaohms.

## 6. ASSEMBLY OF THE MCSG

### 6.4 Requirements regarding the switchgear room

Before installing the switchgear panels, make sure that the switchgear room is checked according to the switchgear documentation (Fig. 6.4.1 & 6.4.2).

- Observe the minimum distance between the switchgear and the wall of the building.
- The load-bearing capacity of the fastening areas must correspond to the weight of the switchgear (perform a stress analysis of the building).
- Check base frame (if used) for dimensions and positional tolerances.
- Check position of floor openings for high-voltage and low-voltage cables.

Before the switchgear is positioned at its site of installation, check that the fastening points are leveled. Unevenness must not exceed  $\pm 2$  mm/meter and 6 mm difference in height over the entire switchgear width.

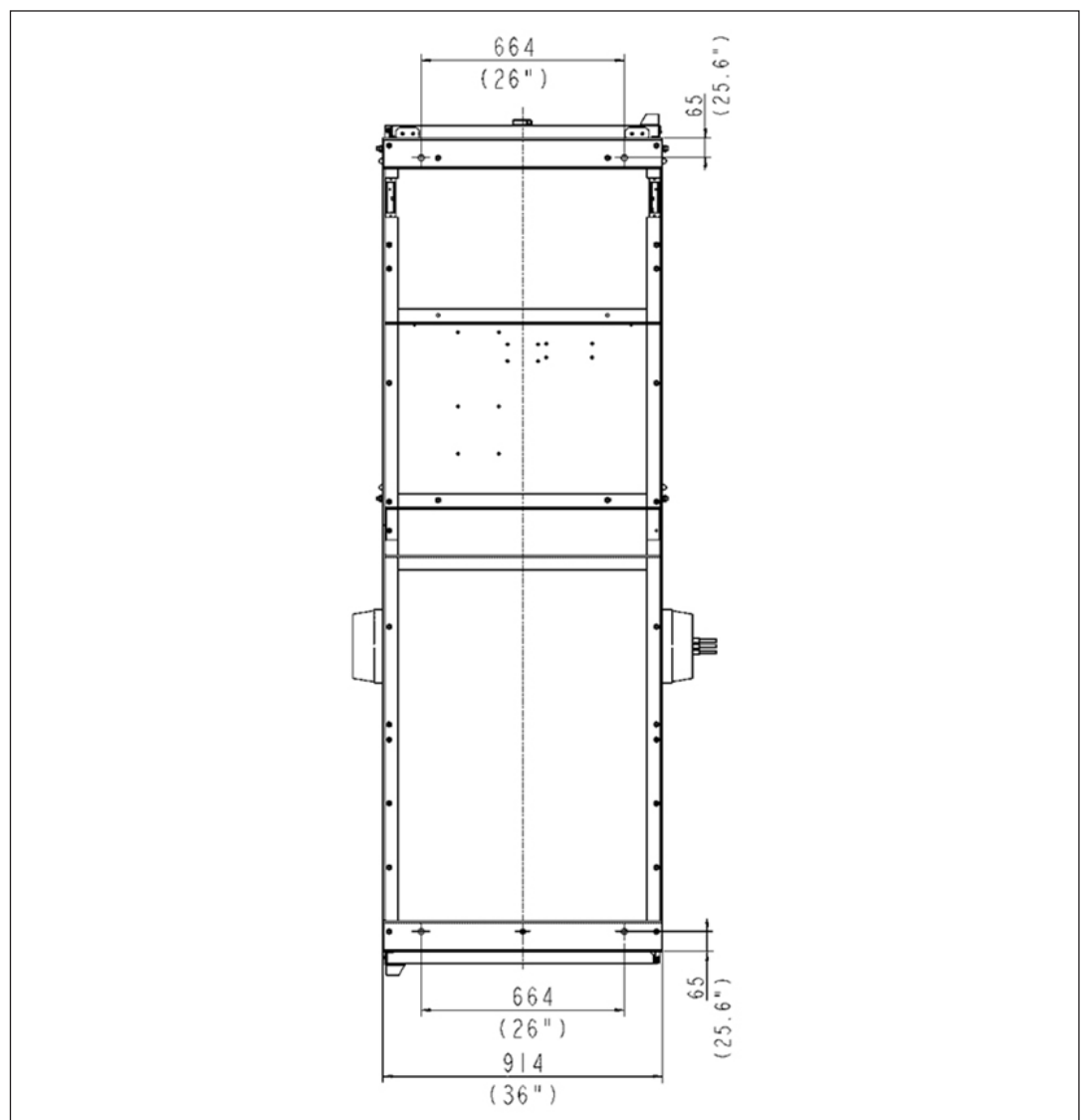

< Fig. 6.4.1 >

# ASSEMBLY OF THE MCSG

## 6. ASSEMBLY OF THE MCSG

### 6.4 Requirements regarding the switchgear room

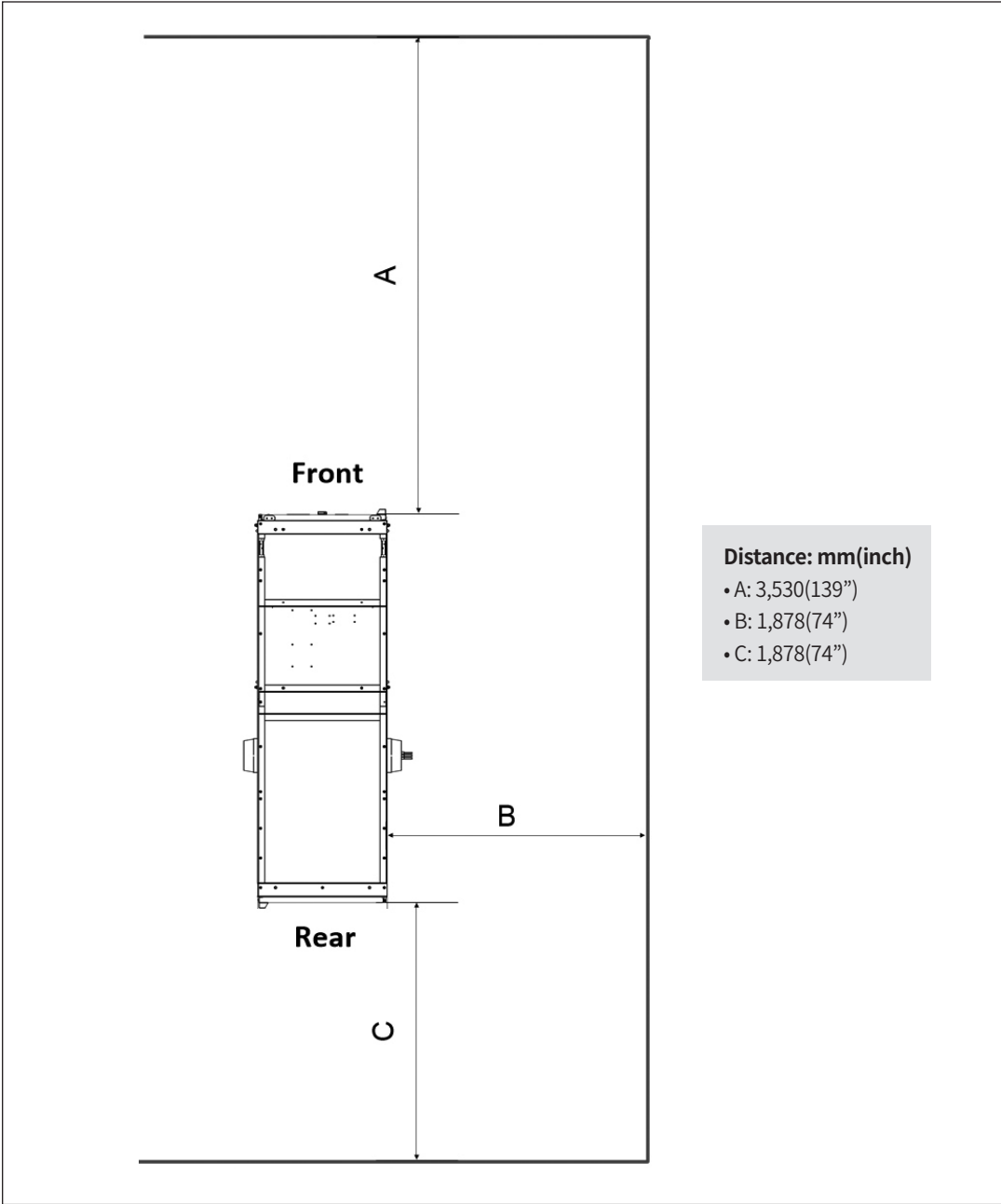

< Fig. 6.4.2 >

## 6. ASSEMBLY OF THE MCSG

### 6.5 Fastening screws for connecting with other panels

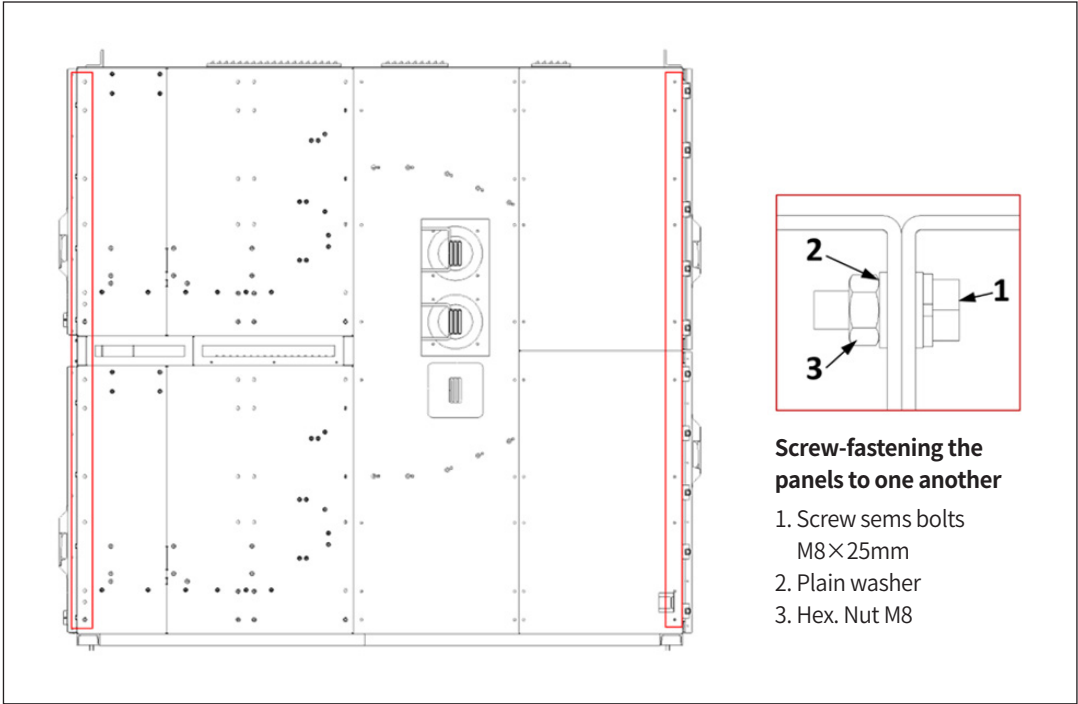

< Fig. 6.5.1 >

### 6.6 Busbar assembly

Number of main busbars per phas	1 busbar (1200A)	2 busbar (2000A)	3 busbar (2500A)
Cross Section [mm]	101.6×6.35 or 101.6×9.53	101.6×9.53	101.6×9.53
Busbar arrangement to the outgoing feeder bar			

Comply with the specifications on treatment of contact surfaces and the tightening torques for busbar screw fastenings in the Table A.

Clean all the contact surfaces of the busbars including outgoing feeder busbars before assembled in the switchgear panels.

# ASSEMBLY OF THE MCSG

## 6. ASSEMBLY OF THE MCSG

### 6.6 Busbar assembly

Observe location of busbars and outgoing feeder bars.

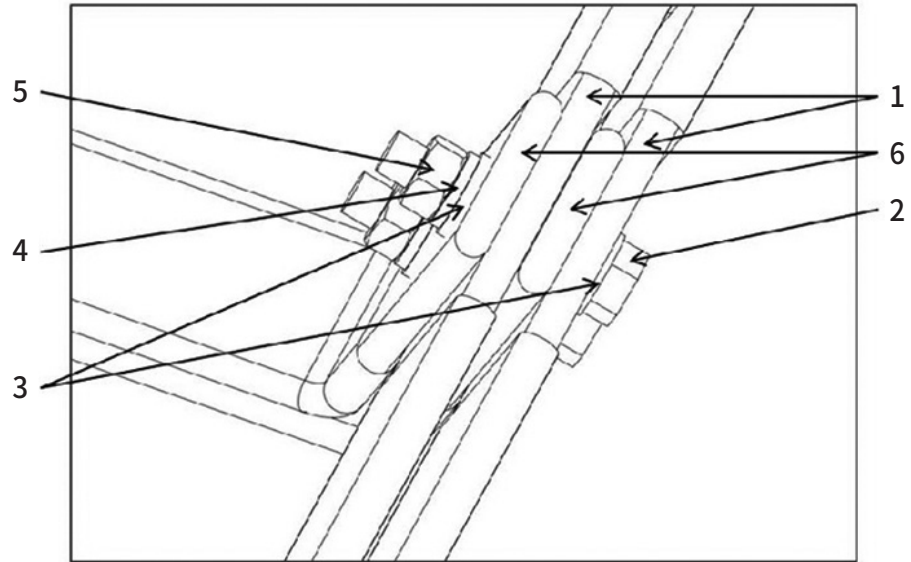

#### Busbar assembly

1. Main busbar  
6.35 × 101.6 (lea: 1200A), or  
9.53 × 101.6 (lea: 1200A, 2ea: 2000A, 3ea: 2500A)
2. Bolt M12
3. Plain washer
4. Spring washer
5. Nut M12
6. Outgoing (Vertical) Busbar  
6.35 × 101.6 (lea: 1200A), or  
9.53 × 101.6 (lea: 1200A, 2ea: 2000A, 3ea: 2500A)

## 6. ASSEMBLY OF THE MCSG

### 6.7 Mounting the Ground(earth) bus

#### Connection between panels

- Connect the ground bus (item 4) to the earthing system of the switchgear. (using M10)

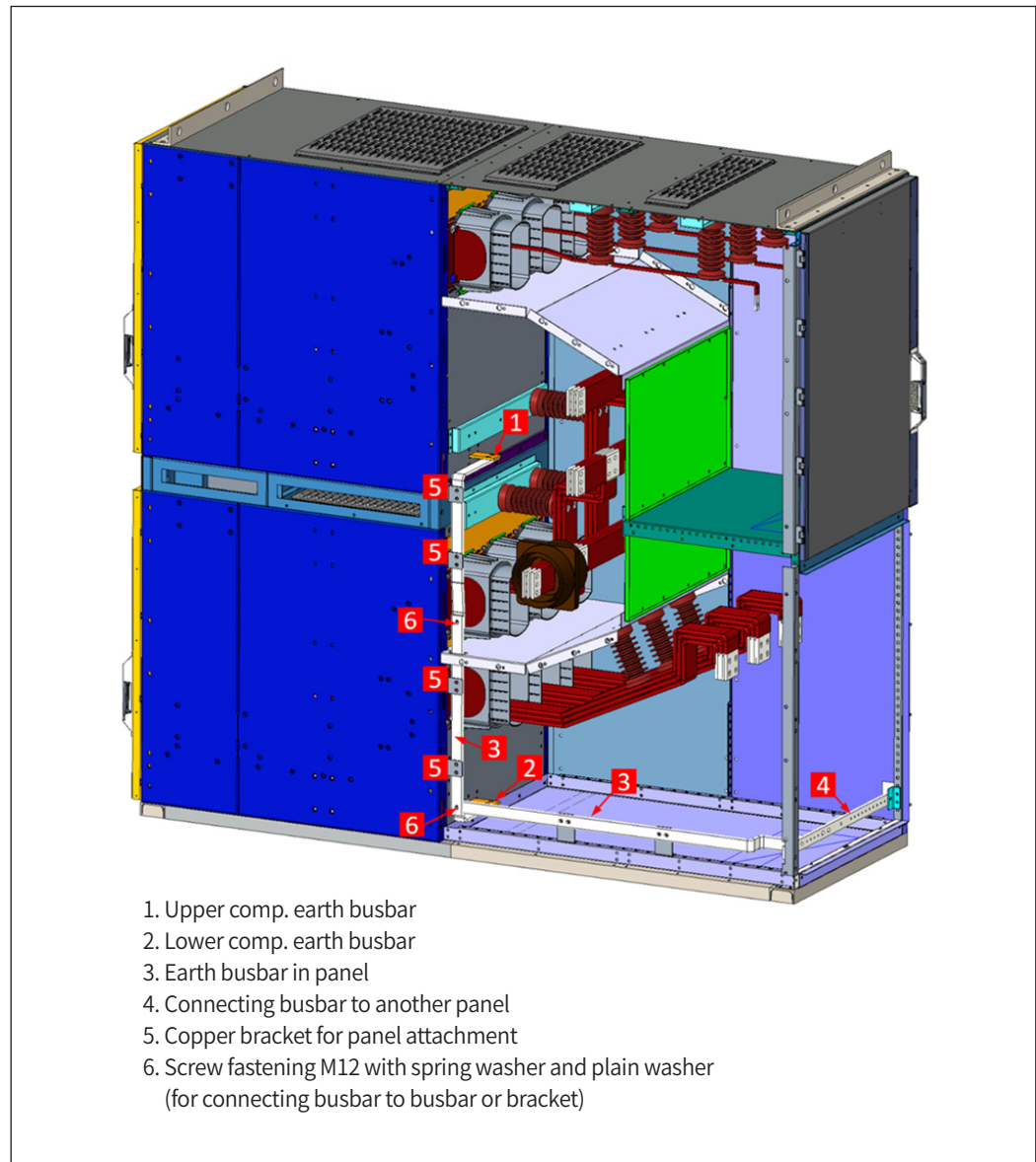

# ACCESSING THE MAIN CIRCUIT COMPARTMENTS

## 7. ACCESSING THE MAIN CIRCUIT COMPARTMENTS

### 7.1 Safety provision and important information



### WARNING

Risk of injury arises if safety provision is not met



### IMPORTANT

The panels can be equipped optionally with additional interlocks for the switching device compartment door.

NO	Interlock	Function of interlock	Method of operation of interlock
1	Between Truck of VCB and VCB Status	VCB cannot be led-in/ withdrawn when the VCB on.	Lead in or withdraw VCB once the open status (VCB Disconnected) of VCB is checked
2	Between Truck of VCB and VCB Status	VCB can be operated (closed or opened) only when it is on Test or Connect/Disconnect position	VCB is operated (VI Connected) after checking that it is reached from Test or Connect/Disconnect position.
3	Between Truck of VCB and Door	The door can't open when VCB is connected or in test position while the VCB compartment door is closed.	Door can only be opened when the VCB located on Disconnect position.
4	Between Truck of VCB and Door interlock.	Lead in and withdrawal of VCB is possible when door is closed (unwind door racking interlock for lead in and withdrawal)	VCB lead in / withdrawal when door is closed or when door racking interlock is removed

## 7. ACCESSING THE MAIN CIRCUIT COMPARTMENTS

### 7.2 Accessing cable compartment



Danger! Always de-energize and ground high-voltage conductors and bus bars before opening the cable compartment.

#### 7.2.1 Open cable compartment door

• Cable compartment

1. Refer to Fig. 7.2.1.1. Open back door handle which is marked in No.1 of the cable compartment.
2. When inner protection doors marked No. 2 in Fig. 7.2.1.2 are installed in the cable compartment, turn the knobs marked No. 3. and then open the inner doors refer to Fig. 7.2.1.3.

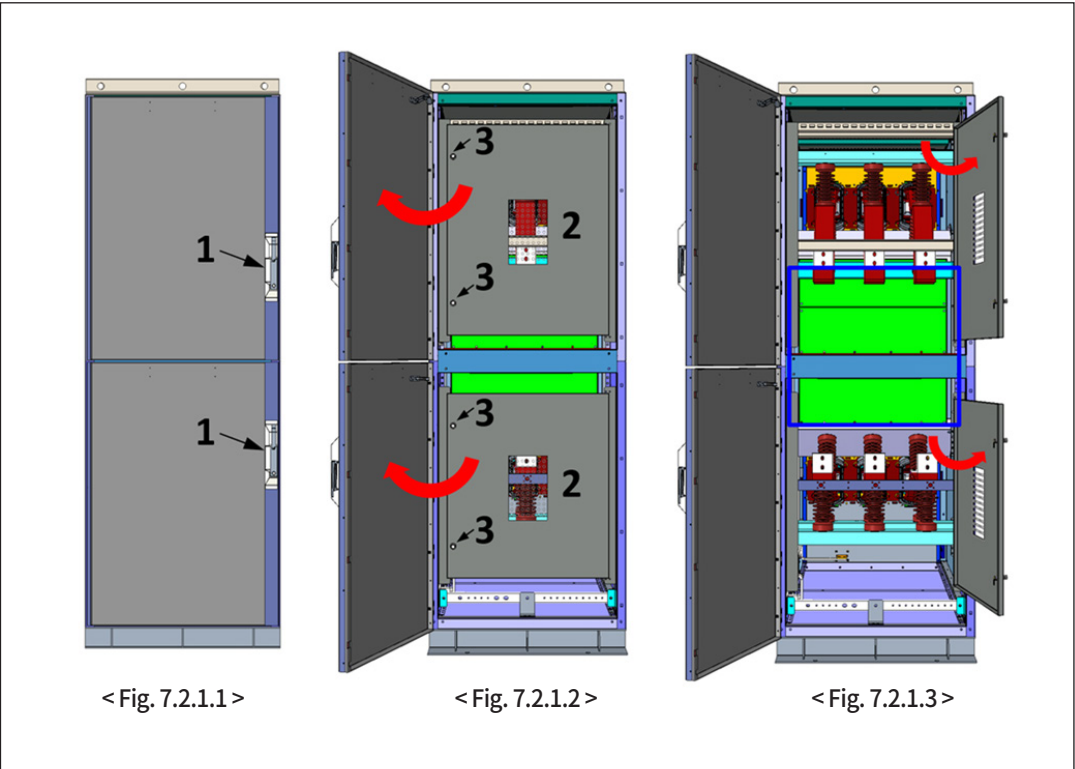

# ACCESSING THE MAIN CIRCUIT COMPARTMENTS

## 7. ACCESSING THE MAIN CIRCUIT COMPARTMENTS

### 7.3 Accessing the VT Compartment

The VT truck should NOT be removed when the VCB is closed in connected position.

1. Refer to the Fig. 7.3.1 & 7.3.3. Open the VT Compartment door.
2. Refer to the Fig. 7.3.2 & 7.3.4. By using the extension rail and lifter, detach VT truck from the VT compartment.

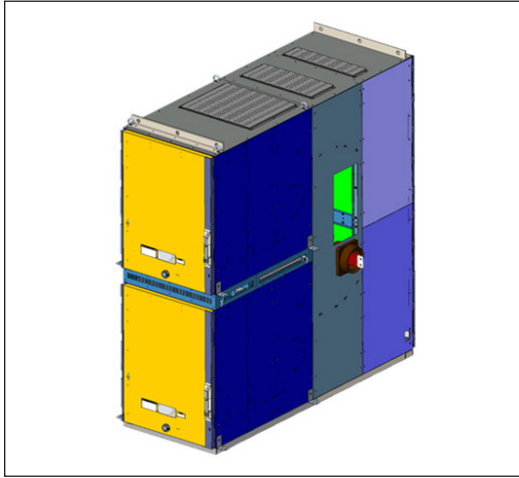

< Fig. 7.3.1 >

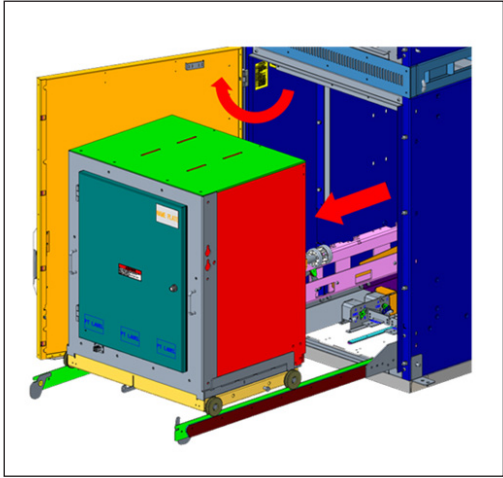

< Fig. 7.3.2 >

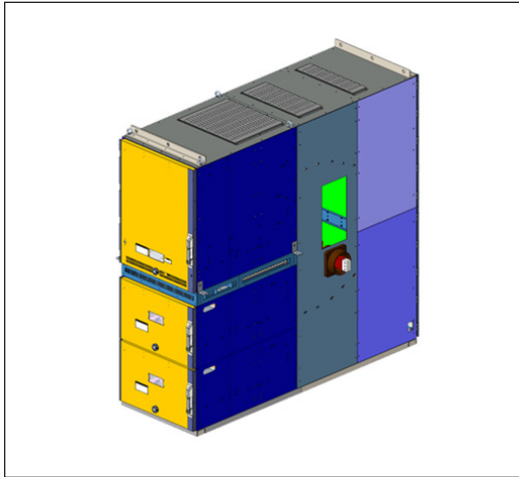

< Fig. 7.3.3 >

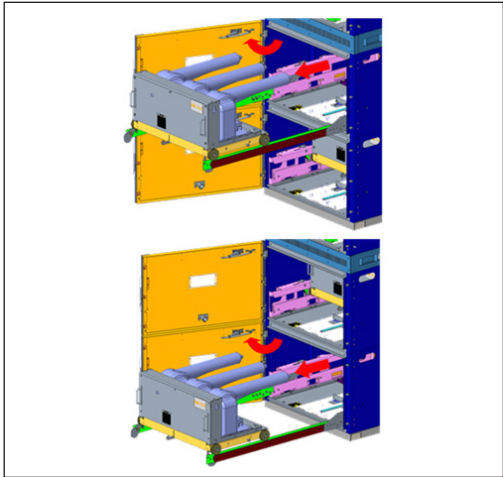

< Fig. 7.3.4 >

## 7. ACCESSING THE MAIN CIRCUIT COMPARTMENTS

### 7.4 Accessing the VCB Compartment

#### **DANGER**

The door of switching device compartment can only be opened when the VCB truck is in the disconnection position.

#### 7.4.1 Opening and closing the door of the VCB Compartment

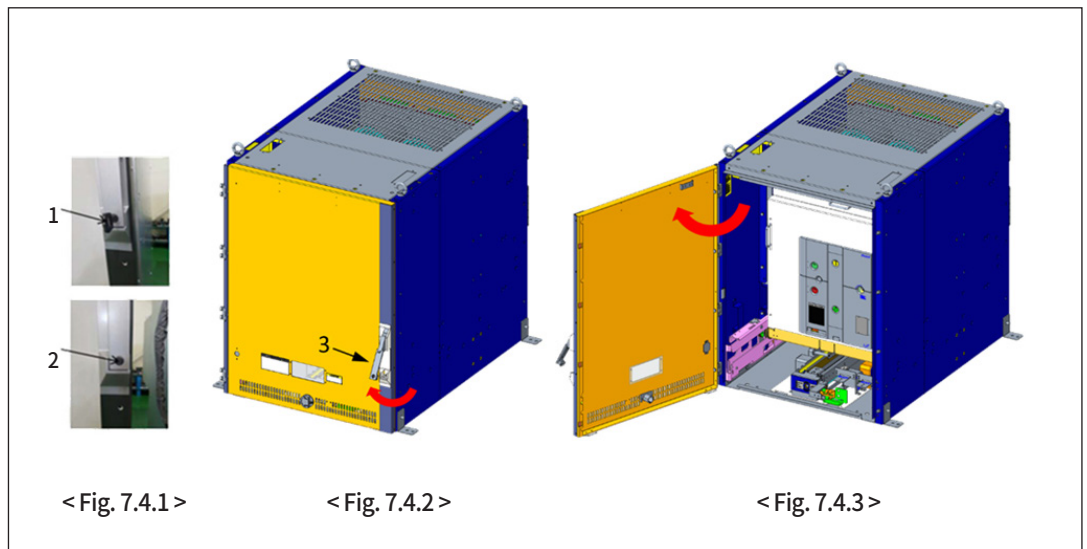

##### • Opening the door

1. If the VCB is installed in the VCB compartment, then make sure that the VCB is in disconnected position.
2. Unlock the door by using the key provided (Refer to Fig. 7.4.1). Lift the door handle which is marked in No.3. And then pull the door handle to open the door.

##### • Closing the door

1. Closing the door is performed in the reverse order of opening the door.

# ACCESSING THE MAIN CIRCUIT COMPARTMENTS

## 7. ACCESSING THE MAIN CIRCUIT COMPARTMENTS

### 7.5 Inserting and removing VCB from the panel

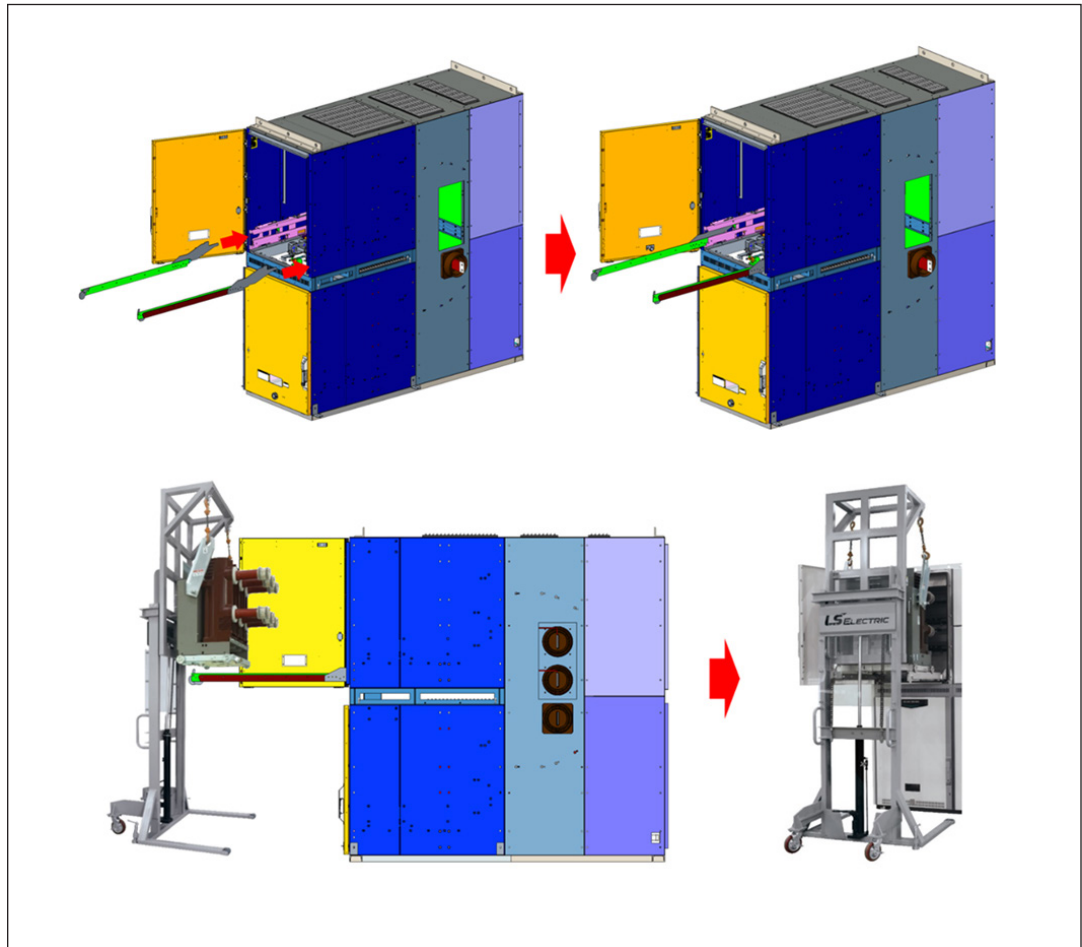

< Fig. 7.5 >

#### • Inserting the VCB into the panel.

1. Open the front door and assemble the extension rails by inserting them into the rails. Refer to 8.2.1.2 for detail.
2. Attach the VCB onto the lifter's chain using lift angle and then adjust the height of the VCB lifter to make sure the rollers of VCB is high enough to put onto the extension rail.
3. Move the VCB lifter in front of the panel with a proper distance and lock it.
4. Adjust the height of VCB lifter to put the VCB on the extension rail. Then detach the lift angles from VCB.
5. Push forward the VCB into the panel then follow the racking in/out operation directions illustrated in 8.2.1.

## 7. ACCESSING THE MAIN CIRCUIT COMPARTMENTS

### 7.5 Inserting and removing VCB from the panel

- **Removing the VCB from the panel is the reverse operation of inserting VCB into the panel.**

1. Assembly the extension rail first and pull out the VCB onto extension rails.
2. Move the VCB lifter in front of the panel with a proper distance and lock it.
3. Adjust the height of the VCB lifter and attach the VCB onto the lifter's chain using lift angle.
4. Lift VCB from extension rail using VCB lifter and remove VCB from the panel.

### 7.6 Accessing busbar compartment



#### **DANGER**

Risk of fatalities due to high voltage. The busbar compartment can only be opened if the busbar is earthed.



#### **WARNING**

The top of panels is not meant to be walked on. Persons may fall and get injured or may damage the panel. Do not step on any devices when working on the top of the panel is required.

# ACCESSING THE MAIN CIRCUIT COMPARTMENTS

## 7. ACCESSING THE MAIN CIRCUIT COMPARTMENTS

### 7.6 Accessing busbar compartment

#### 7.6.1 Accessing busbar compartment through top or bottom cable compartment

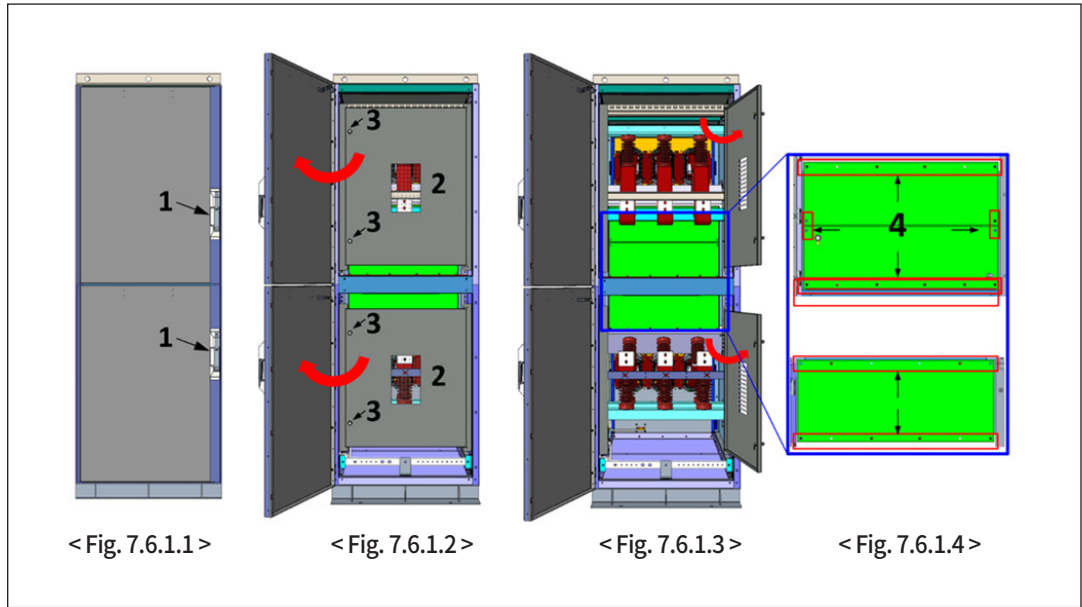

**Open the door and electrical accessories by following procedures for access of busbar compartment through the top and bottom cable compartment.**

1. Open the upper or lower door which is marked in No.1 in Fig. 7.6.1.1.
2. When inner protection doors marked No. 2 in Fig. 7.6.1.2 are installed in the cable compartment, turn the knobs marked No. 3 and open the inner doors in Fig. 7.6.1.3. If electrical accessories such as cable, Lightning Arrester (LA) and etc. are installed in the cable compartment, these accessories may need to be removed so as to get access to bus compartment cover.
3. Finally, remove the M8 bolts which are marked No.4 in Fig. 7.6.1.4 for getting rid of bus compartment cover.

## 8. OPERATION

### ※ Note on safety at work

The relative work and operating procedures must be carried out carefully by trained specialists familiar with the installation, taking into account all the relative safety regulations according to the IEEE/ANSI and other relevant professional bodies, as well as any local and work regulations and instructions.



### WARNING

Do not walk on the top of the switchgear panels  
(Rupture points for pressure relief if applicable).  
The pressure relief devices could be damaged. (If provided)

## 8.1 Commissioning

### 8.1.1 Preparatory work

**In preparation for commissioning, the following work must be carried out prior to connection with the high voltage power supply:**

- Check the general condition of the switchgear for any damage from defects.
- Visually inspect the switching devices, withdrawable parts, isolating contacts, insulating parts, and, etc.
- Check connection of the main earthing bar to install earthing conductor (follow the appropriate safety regulations).
- Check the paintwork for damage, and touch up if necessary.
- Remove all residue materials, foreign bodies, and tools from the switchgear.
- Clean the switchgear, rub down insulating parts with a soft, dry, clean, and non-fraying cloth. Remove any greasy or sticky dirt.
- Correctly remount all covers, etc. removed during assembly and testing procedures.
- Perform AC voltage testing of the main circuits according to IEEE/ANSI Std. if necessary. Pay special attention to voltage transformers and cables, etc. during this procedure.
- Switch the auxiliary and control voltage on.
- Carry out testing operations on switching devices manually or by electrical control while simultaneously observing the relative position indicators.
- Check mechanical and electrical interlocks for effectiveness, without using force.
- Set the protective devices in the switchgear to the required values and check their function with test equipment.
- Instruct local operators regarding the basic details of regular handling of the switchgear.
- Check readiness for operation and switching status of electrical systems upstream and downstream of the switchgear.

## 8. OPERATION

### 8.1 Commissioning

Depending on allocation of responsibilities, it may also be necessary to check the following equipment in area adjacent to the switchgear.

- Power cables
- Auxiliary cables
- Auxiliary power source
- Remote control system
- Switchgear room equipment
- Switchgear room conditions

#### 8.1.2 Start-up

- Comply with all relevant safety regulations.
- Ensure that the circuit-breakers in the system are in OFF position.
- Remove any existing earthing and short circuit connections in the critical switching area.
- Energize the feeder cables.
- Connect the switchgear step by step, observing the signals and indicators.
- Check that relative conductors are in phase, where necessary, when there are several incoming feeder cables and switchgear section.
- Carry out all measurements and check all functions which depend on high voltage power supply being connected.
- Watch out for any irregularities.

## 8. OPERATION

### 8.2 Switching Operation

#### 8.2.1 Racking In/Out Operation

If switchgear and circuit breaker are delivered separately, skip 8.2.1.1. If switchgear is delivered with Circuit Breaker, the Vacuum Circuit Breaker will be installed inside CB Compartment. In this case, the vacuum circuit breaker will be inserted in CB Compartment and fixed with brackets.

For racking in the circuit breaker or taking out from the CB Compartment, the fix brackets need to be removed.

##### 8.2.1.1 Removing Fix Bracket

- 1) Open the CB Compartment door.
- 2) Unfastening the Bolt(8points). This bolt size is M6(10mm, 3/8inch). See Figure 8.2.1
- 3) Removing the bracket.

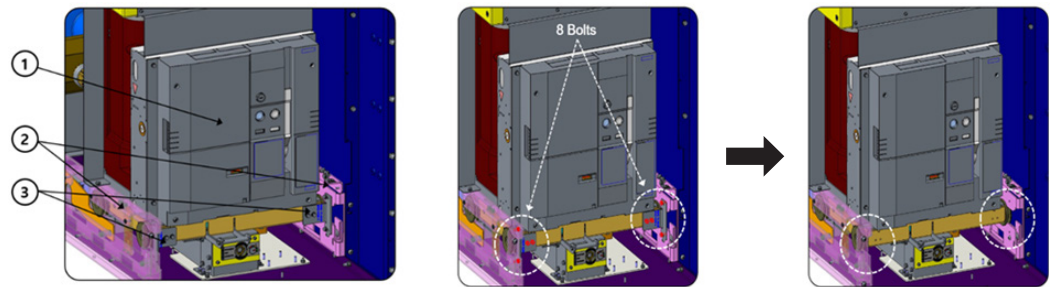

< Fig. 8.2.1.1 >

##### 8.2.1.1 Inserting Circuit Breaker into CB Compartment

###### 8.2.1.2.1 Assembling the Extension Rails to CB Compartment

- 1) Lifting the extension rail and inserting into the rail.
- 2) In Fig.8.2.4, a guide bush is on near the entrance.
- 3) Making the extension rail with 30 degrees from the ground and inserting it into the entrance (Fig.8.2.3 and 8.2.4).
- 4) Put the tips of extension rail on the guide bush and push it forward.
- 5) When the extension rail stop inserting, Checking the extension rail meets edge of the rail entrance (See Fig. 8.2.5).
- 6) When the extension rail meets edge of the rail entrance, push it down.

## 8. OPERATION

### 8.2 Switching Operation



< Fig.8.2.3 Inserting extension rail >

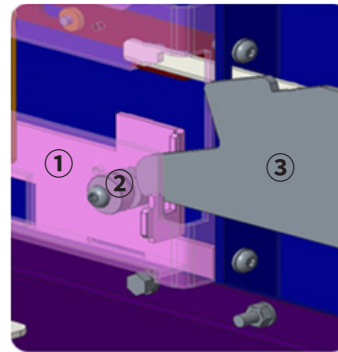

- ① CB Rail
- ② Guide Bush
- ③ Extension Rail

< Fig.8.2.4 Assembly parts >

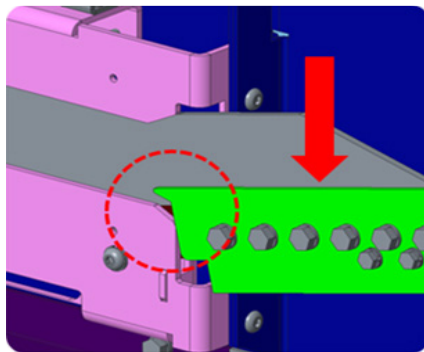

< Fig.8.2.5 Contact edge >

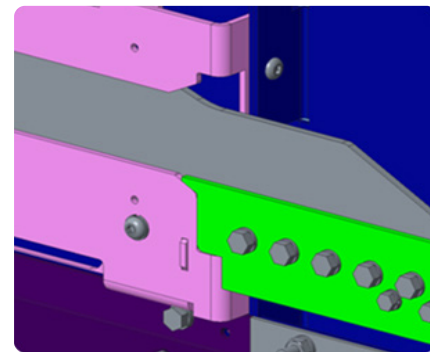

< Fig.8.2.6 Finish Assemble >

#### 8.2.2.2 Inserting Circuit Breaker into CB Compartment

- 1) Before inserting the circuit breaker, make sure that the circuit breaker is 'OPEN' and 'Discharge'.
- 2) Put the circuit breaker on the extension rail. The gap in the wheel should fit on the extension rail.
- 3) Push forward the circuit breaker.
- 4) When the circuit breaker stop inserting, lifting up the interlock lever and push it forward less than 0.5inch(13mm).

**If the circuit breaker is 'Close', 'Charged' or both, very loud sound may occur because of Auto Discharge(Trip) function.**

- 5) Take off your hand from the lever, and push the circuit breaker forward slowly.
- 6) When the circuit breaker reaches 'Disconnect' position, Interlock lever lifts down automatically.

## 8. OPERATION

### 8.2 Switching Operation

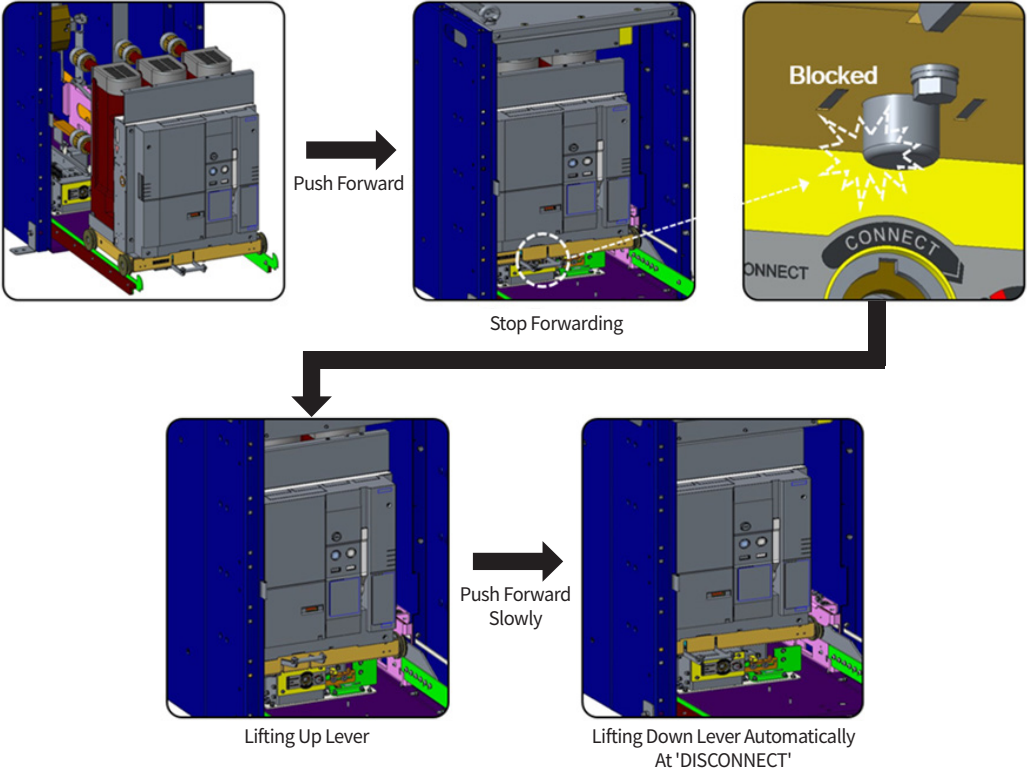

< Fig.8.2.7 Process of Inserting the Circuit Breaker >

### 8.2.2 Manual Racking-In/Out operation

The circuit breaker is designed with three different positions, 'Disconnect', 'Test' and 'Connect'. In order to rack in/out the circuit breaker, racking in/out handle should be inserted into the hole which located on the bottom of the door(See Fig.8.2.8 and 8.2.9).

This process can apply to the ground truck equally.

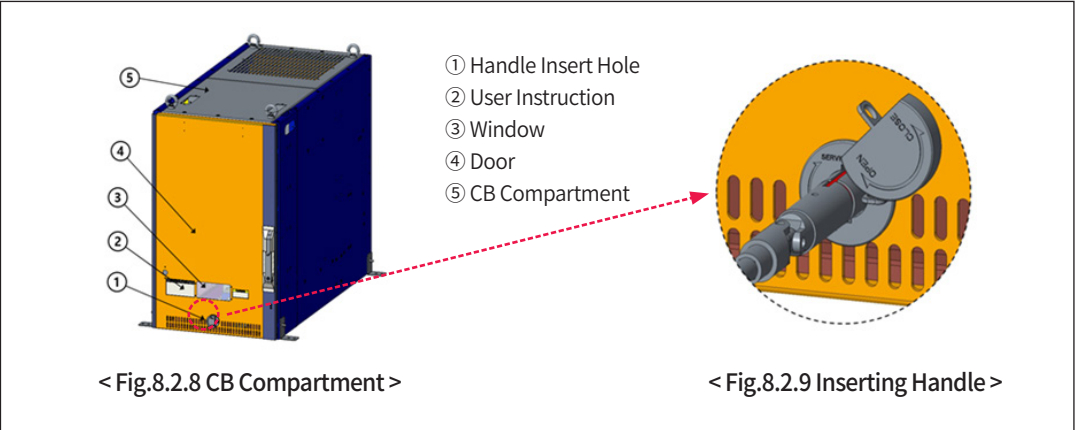

< Fig.8.2.8 CB Compartment >

< Fig.8.2.9 Inserting Handle >

## 8. OPERATION

### 8.2 Switching Operation

#### 1) Racking In Operation (Disconnect → Test → Connect) with Door Close

- Checking the circuit breaker status. Before the racking in operation, the circuit breaker should be 'OPEN' Status.
- Inserting the racking handle in to the hole(See Fig.8.2.9).
- From the 'Disconnect' position to 'Test' position, Rotating the handle about 4 times clockwise direction. There is no idling rotation in 'Test' position. The position indicator will point the 'T'.
- From the 'Test' position to 'Connect' position, rotating the handle about 21 times clockwise direction. If the circuit breaker reached 'Connect' position, handle will be idling. The position indicator will point the 'C'
- The control power will be connected automatically when the circuit breaker approaches to 'Test' position. Therefore, in 'Disconnect' position the circuit breaker will be operated manually.
- After passing the 'Test' position, shutter will start to open. In this point, racking torque increases sharply.
- Racking in torque increased again when the tulip contactors connect with bushing terminals.
- Between 'Disconnect' to 'Test', 'Test' to 'Connect', position indicator points the middle of 'D' to 'T' and 'T' to 'C' (See Fig.8.2.11).

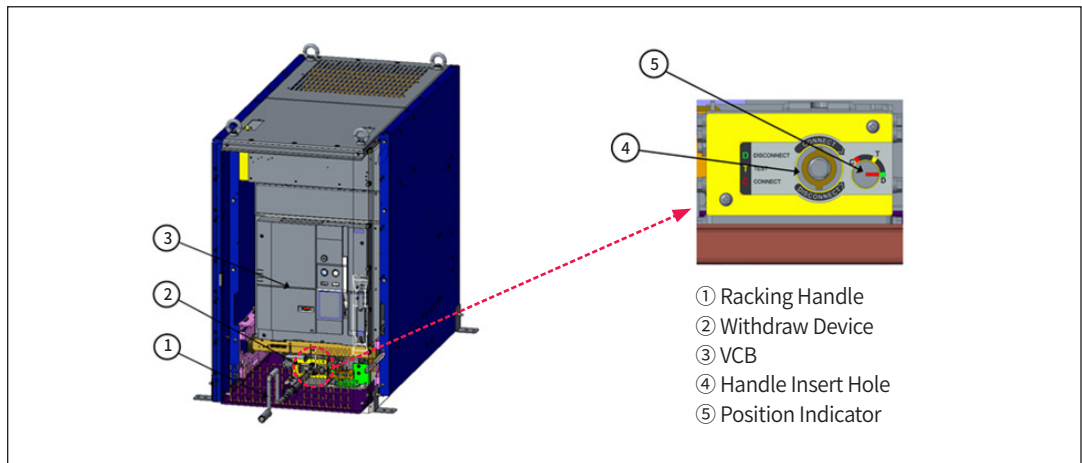

< Fig.8.2.10 Racking In/Out Device >

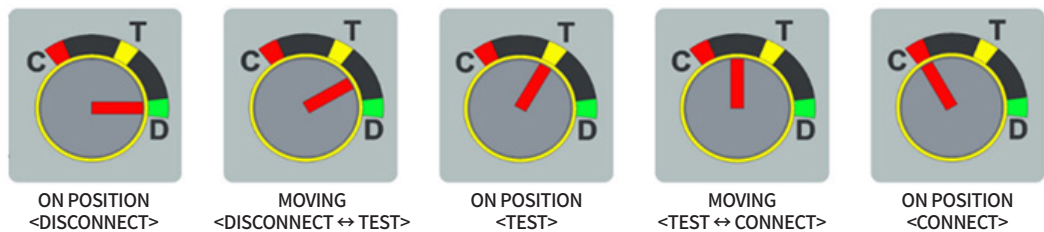

< Fig.8.2.11 Status of position indicator at each positon >

## 8. OPERATION

### 8.2 Switching Operation

#### 2) Racking In Operation (Disconnect → Test → Connect) with Door Open

For preventing the unexpected accident, the racking in/out handle cannot be inserted by racking interlock when the compartment door is open. For the racking in operation, the racking interlock should be released first.

- a. Pushing the racking interlock push plate for releasing the interlock.(Fig.8.2.12 Right)
- b. Inserting the bolt to the hole. The bolt should be around 1/4 inches.(Fig.8.2.12 Right)
- c. After releasing the interlock, following the racking in operation instruction on page 53.

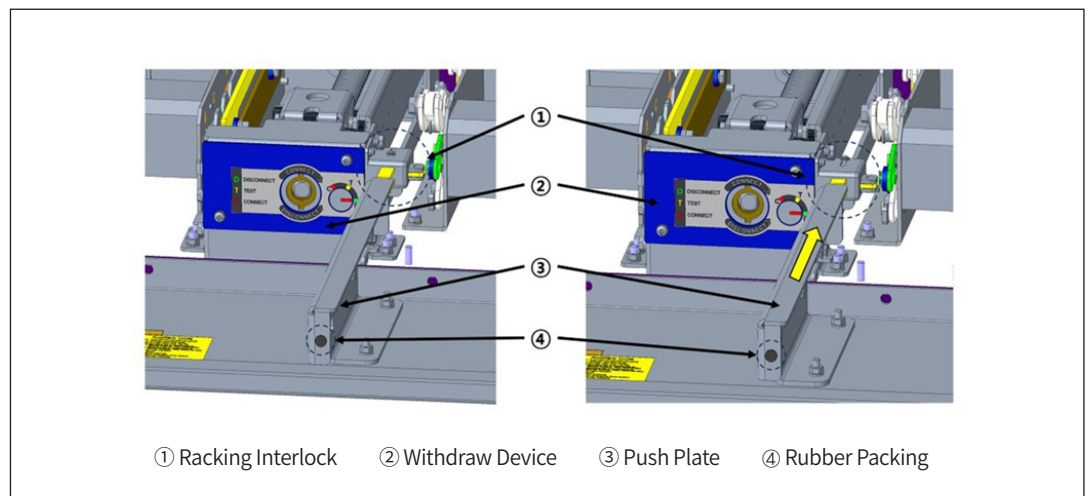

< Fig.8.2.12 Releasing Racking Interlock Manually >

#### 3) Racking Out Operation (Connect → Test → Disconnect) with Door Close

- a. Checking the circuit breaker status. Before the racking out operation, the circuit breaker should be 'OPEN' Status.
- b. Inserting the racking handle in to the hole(Fig.8.2.9).
- c. Racking out operation is opposite sequence of racking in operation. Turn the handle counter clockwise direction.
- c. If the circuit breaker reached 'Disconnect' position, handle will be idling. The position indicator will point the 'D'.
- d. The control power will be disconnected automatically when the circuit breaker leaves from 'Test' position.

#### 4) Racking Out Operation (Connect → Test → Disconnect) with Door Open

When the circuit breaker is in the 'CONNECT' position, the compartment door cannot be opened by door interlock. **The LS does not recommend to open the compartment door when the circuit breaker is in the 'CONNECT' position.** However, if there is an emergency situation which requires to open the compartment door, see Fig.8.2.13 for removing the door Interlock.

After removing the door interlock, following the racking instruction for releasing the racking interlock and racking out operation.

※ After all the work, make sure the rubber packing(④) is in the position shown in Fig.8.2.12. If rubber packing is missing, in/out operation may not be possible when the door is closed.

## 8. OPERATION

### 8.2 Switching Operation

※ Discharging the door interlock

The LS does not recommend to open the compartment door when the circuit breaker is not in the 'DISCONNECT' position. However, if the compartment door needs to open when the emergency situation, the door interlock can be discharged easily. For discharging the door interlock, follow the process below.

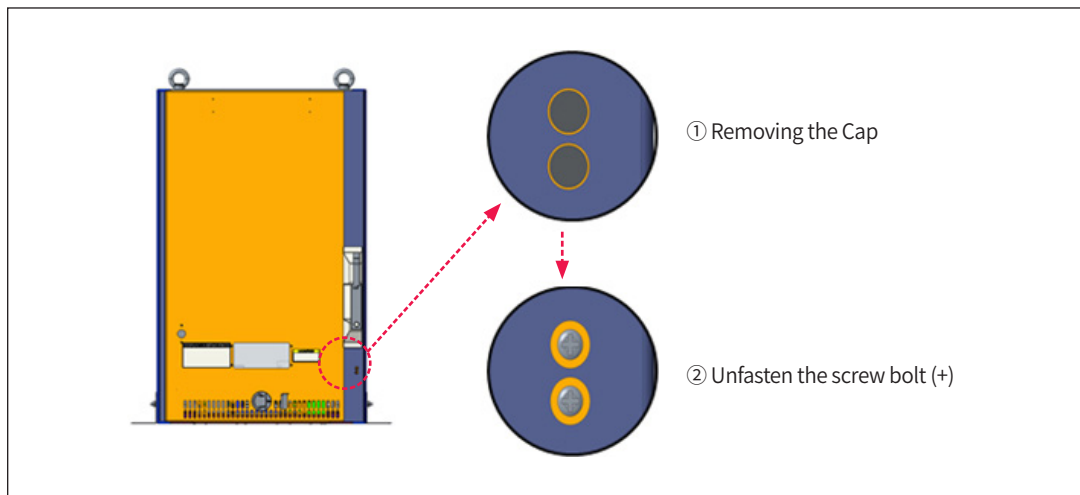

< Fig.8.2.13 Discharging The Door Interlock >



### CAUTION

The insertion and withdrawal must always be carried out with the apparatus open!  
Withdrawal from the test/disconnected position:

- Open the door of the circuit-breaker compartment.
- Release control wiring plug and place it in the storage position on the withdrawable part.
- Position the service truck at the correct height facing the panel front.
- Draw out the withdrawable part in the service truck and secure it in the catches on the truck.
- Release the service truck from the switchgear panel.
- Secure the position of the shutters with the padlock.

#### **Insertion from the service truck into the test/disconnected position;**

- Carry out the procedure described above in reverse order to insert.

## 8. OPERATION

### 8.3 Space Heater

Under normal conditions, space heaters will be operating. Space heaters help reduce condensation by elevating the switchgear slightly above ambient temperature. If space heater fails, it should be replaced as soon as possible.

### 8.4 Busbar

#### 8.4.1 Accessing Busbar

Live busbar is behind bolted panels. Never remove these panels until the busbar is de-energized. Review construction drawings before doing any work. These will show which barriers must be removed to reach any particular bus. The switchgear busbar has been sectionalized to isolate any shorts, over voltages, or other issues and limit their effect. Always replace barriers once work is completed.

#### 8.4.2 Busbar Inspection and Cleaning

Use megger to measure the insulation resistance of busbar phase to phase and phase to ground. Record the results as well as the temperature and the humidity in a maintenance log for the switchgear. If there is any possibility of deterioration of the insulation, the recording data would be helpful.

Inspect busbar insulation for signs of deterioration. Cracking, crazing, tracking, residue deposition, or discoloration are signs of degradation. Pay special attention to areas around busbar supports, bus insulators, busbar joins, and busbar connections. Wipe busbar with clean rags after the inspection.

### 8.5 Voltage transformer

Voltage transformers are mounted on the cart. When the VT Truck is withdrawn, it is disconnected from the main circuit and then grounded. The VT Truck should be checked to ensure it operates smoothly. Once Voltage transformer is inserted, it is required to check whether the door of the VT Compartment is open or not.

#### 8.5.1 Block-type VT Truck(1-High) Fuse Replacement Manual

1. Draw out VT Truck from the VT compartment according to Fig. 7.3.1 & 7.3.2



VOLTAGE TRANSFORMER TRUCK ASS'Y

# OPERATION

## 8. OPERATION

### 8.5 Voltage transformer

2. Open the door of VT truck according to Fig. 8.5.2.1

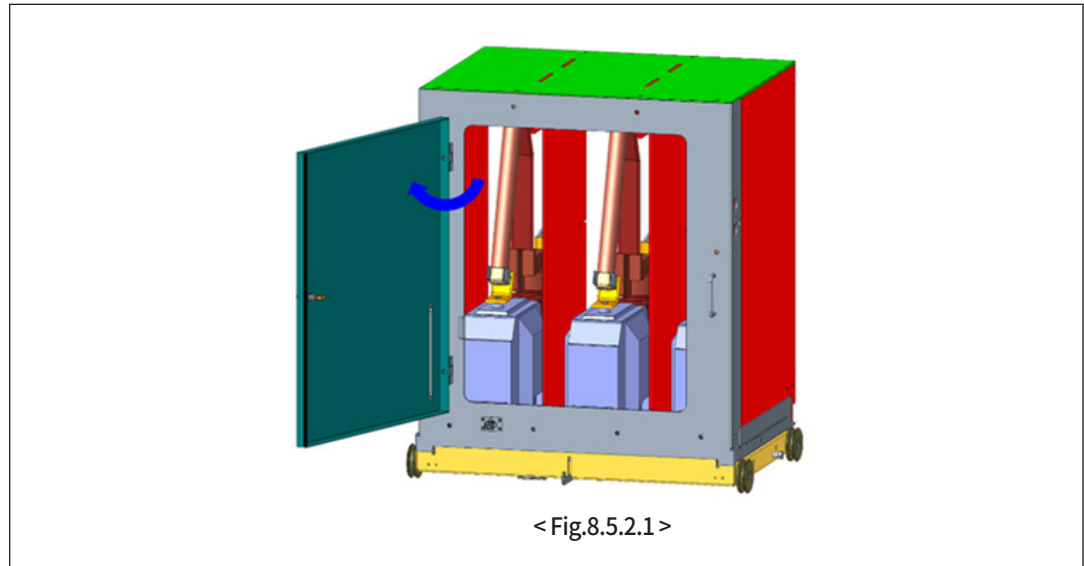

3. Remove the fuses from the fuse clip and replace them with new ones. Refer to Fig. 8.5.2.2

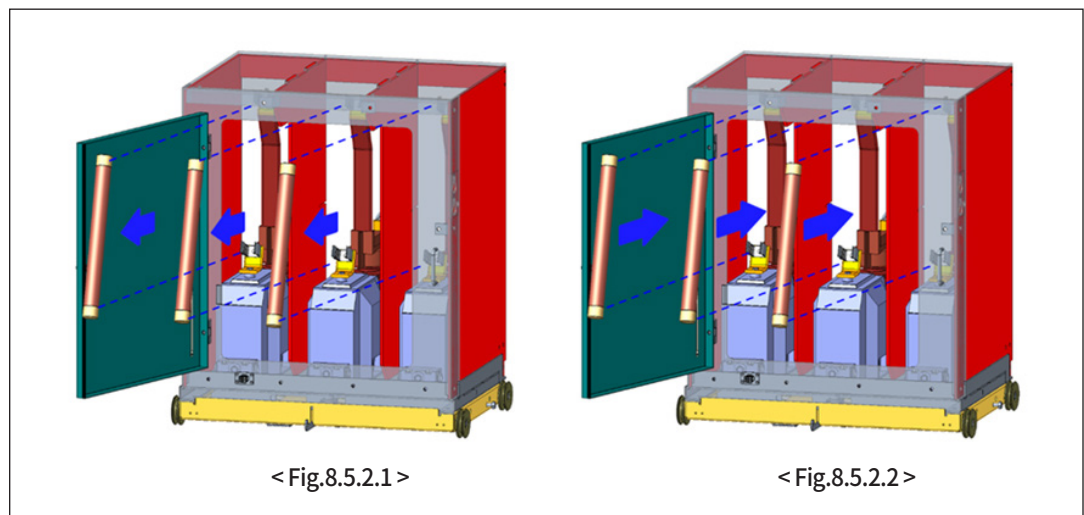

## 8. OPERATION

### 8.5 Voltage transformer

#### 8.5.2 Gun-type VT Truck(1/2-High) Fuse Replacement Manual

1. Draw out VT Truck from the VT compartment according to Fig. 7.3.3 & 7.3.4.

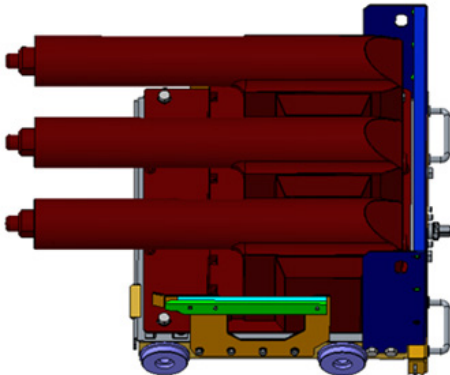

VOLTAGE TRANSFORMER TRUCK ASS'Y

2. Unwind fuse contact ass'y

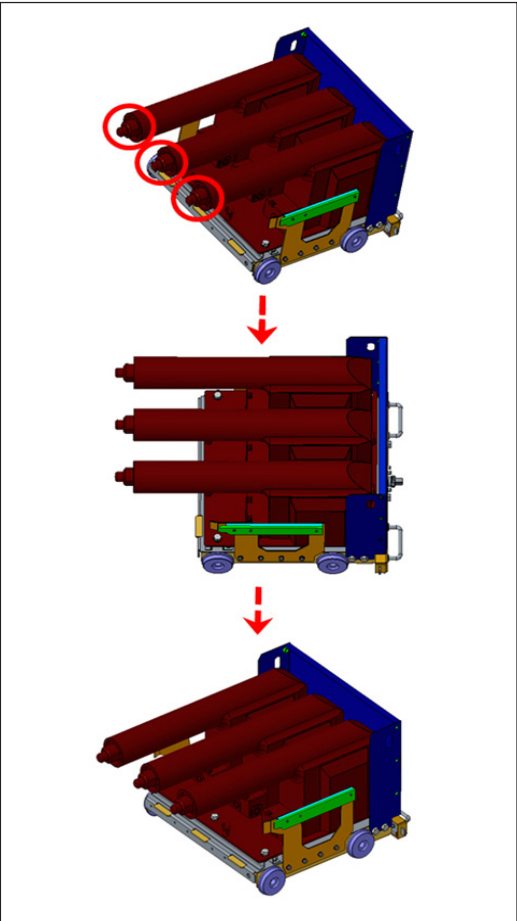

Unwind by turning fuse holder counter clockwise

3. Replace the fuses

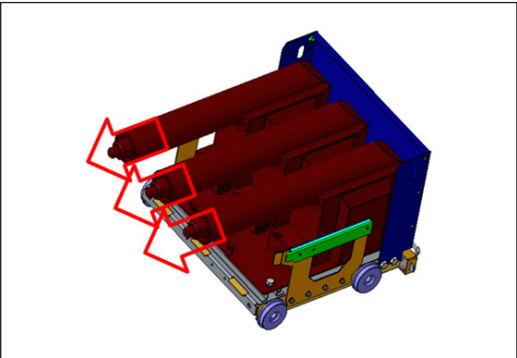

Remove the fuse holder, then replace the fuse.  
And assemble fuse holder by turning clock wise

# OPERATION

---

## 8. OPERATION

### 8.6 Ground & Test Devices

If grounding of the main circuit is required, then the ground & test devices can be used. For more information about ground & test devices, please refer to the ground & test devices manual.

### 8.7 Breaker Lifter

Breaker lifter is an optional accessory, and the manual of breaker lifter is provided separately. For more information, please refer to the breaker lifter manual.

### 8.8 Motor Control Racking System

MCRS, the abbreviation of Motor Control Racking System, is an optional accessory, and the manual of MCRS is provided separately. For more information, please refer to the MCRS manual.

## 9. INSPECTION & MAINTENANCE

### 9.1 General



### DANGER

- 1. Do not touch the live part (conductor, terminal connecting part) while a live current is flowing.**

Electric shock can cause a serious injury or death.



### WARNINGS

- 1. Do not operate, inspect or repair unless you are an expert.**  
It may cause a malfunction, injury or electric shock.
- 2. Do not open doors or protective covers while a live current is flowing.**  
It may cause an electric shock.
- 3. Do not insert a metal bar while a live current is flowing.**  
It may cause an electric shock.
- 4. Do not measure using a tape measure while a live current is flowing.**  
It may cause an electric shock.
- 5. Do not lift the shielding plate of live part while a live current is flowing.**  
It may cause an electric shock.
- 6. Do not open the secondary side of the current transformer for instruments while a live current is flowing.**  
It may induce the high voltage and ignite a fire.
- 7. Make sure the charging current is fully discharged before maintenance.**  
It may cause an injury or electric shock.
- 8. Tighten bolts and screws with specified torque.**  
It may cause overheating and ignite a fire.
- 9. Do not use damp or water-soaked insulation rods when opening and closing the fuse.**  
It may cause an electric shock.
- 10. When opening the disconnecting switch, open the lower circuit breaker first.**  
It may cause a short circuit and injury due to arc heat.

# INSPECTION & MAINTENANCE

---

## 9. INSPECTION & MAINTENANCE



### WARNINGS

- 11. Turn off the circuit breaker and keep it in the test position during inspection.**  
It may cause an electric shock.
- 12. Turn off the upper & lower circuit breaker & bus tie circuit breaker and keep them in the test position.**  
It may cause an electric shock.
- 13. Use an appropriate measuring instrument when checking the status after turning the power off.**  
It may cause an electric shock.
- 14. Do not use bolts longer than the specified length.**  
It may cause a short circuit and ignite a fire.
- 15. Do not wipe the surface of the running product with a wet cloth after completing an installation, inspection or maintenance.**  
It may cause an electric shock.



### CAUTION

- 1. Do not change the circuit at your own discretion.**  
It may cause a malfunction or failure.
- 2. Do not disassemble, change or modify the product at your own discretion.**  
It may cause a short circuit or overheating, and the product quality cannot be guaranteed.

## 9. INSPECTION & MAINTENANCE

### 9.1 General

Maintenance serves to preserve trouble-free operation and achieve the longest possible working life of the switchgear. It comprises the following closely related activities;

- **Inspection : Determination of the actual condition**
- **Servicing : Measures to preserve the specified condition**
- **Repair : Measures to restore the specified condition**

※ **Note:**

When carrying out all maintenance work, the regulations in the country of installation must be strictly complied with.

Maintenance work may only be performed in a careful manner by trained personnel familiar with the characteristics of the individual switchgear, in accordance with all relevant ANSI safety regulations and those of other technical authorities, and with other overriding instructions. It is recommended that LS ELECTRIC service personnel are called in to perform the servicing and repair work detailed below.

The inspection and service intervals for some of the equipment/components (e.g. parts subject to wear) are determined by fixed criteria, such as switching frequency, length of service, and number of short-circuit breaking operations. On the other hand, for other parts the length of the intervals may depend, for example, on the different modes of operation in individual cases, the degree of loading, and also environmental influences (including pollution and aggressive air).

### 9.2 Classification of Periodic Inspection

- Where necessary, the working area must be isolated and secured against reconnection in accordance with the Safety Regulations specified by ANSI and appropriate national standards before inspection.
- Correct condition of the switchgear should be monitored by regular inspections.
- Under normal operating conditions, inspection should be carried out once every four years by specially trained professional electricians.
- Under abnormal operating conditions (including adverse climatic conditions) and/or special environmental stresses (heavy pollution and aggressive atmosphere, among others), inspection may be necessary at shorter intervals.
- Periodic inspection is primarily a visual inspection for grime, corrosion, and moisture.
  - Effects of high temperature on the main circuits.
  - Traces of partial discharge on the insulating material parts.
  - Traces of leakage current on the insulating material parts.
  - Surfaces of the contact systems.
- However, inspection must also include correct mechanical/electrical operation of the following parts: switching devices, actuating, interlocking, protection, and signaling devices.

# INSPECTION & MAINTENANCE

## 9. INSPECTION & MAINTENANCE

### 9.2 Classification of Periodic Inspection



### CAUTION

Instrument transformer circuit

- With regard to the switching devices, their separate Instruction manual should be followed.
- Check all switchgear accessories and auxiliary devices (e.g. storage batteries).
- Partial discharge must not occur on the surfaces of equipment at operating voltage. It can be detected by characteristic noises, a clearly perceptible smell of ozone, or visible glowing in the dark.
- Visually check the contact system. We recommend turning the contact system alternately in order to clean the inner contact points of the contact system.  
The contact points should be cleaned if signs of overheating (discolored surface) are visible.
- If any irregular conditions are detected, then relative repair measures must be taken.

< Table B > For inspection, restricted condition is necessary as follows

Classification of inspection	Restricted Condition	Opening and closing of door	Separation of cover	Un-interruption of power	Circuit power failure	Interruption of main bus power	Inspection period
Visual inspection		0	-	0	-	-	Once /Month
Monthly inspection		0 (Note 2)	-	0	-	-	Once /Month
Annual inspection		0	0	-	0	0 (Note 3)	Once /Year
Temporary inspection		0	0	-	0	0	-

#### ※ Note:

1. Choose the inspection period by referring to the Table B.
2. At the time of power failure, it is possible to check whether the MCC door is opened and also it is recommended to check whether the door is opened once a month.
3. Power outage is unusual, but the inspection under power outage is carried out necessarily every two years.

## 9. INSPECTION & MAINTENANCE

### 9.2 Classification of Periodic Inspection

#### 9.2.1 Visual inspection

Check the devices which is installed on the door, for example, meter, lamp, switch and so on whether it is damaged or not.

#### 9.2.2 Planned inspections

These inspections are considered planned examinations, required to confirm that system components are functioning as required. The inspections are scheduled, taking into account operating requirements, environmental conditions etc., at regular intervals with precise work instructions and systematic checks to be undertaken.

#### 9.2.3 Planned inspections routine

This consists of periodical inspections on a monthly and annual basis.

#### 9.2.4 Monthly inspections

These involve visual inspections requiring doors to be opened which are admissible without interrupting the supply, and where necessary.

- Indication lamp replacement
- Correct any observed abnormality

#### 9.2.5 Annual inspections

These require a full operational test to be performed ensuring all equipment is fully and efficiently operating without any abnormalities.

All equipment and components should be inspected according to manufacturer's data.

Where equipment is required to maintain its supply, caution should be exercised during inspection.

If a full inspection is not possible as energization needs to be maintained, then a visual inspection should be performed, and a full operational inspection must be rescheduled for more convenient time in the near future.

# INSPECTION & MAINTENANCE

## 9. INSPECTION & MAINTENANCE

### 9.3 Maintenance and Repair of Equipment

Restrictions imposed by the equipment should be highlighted where applicable.

#### 9.3.1 Isolating procedure of the main busbar for SWGR

- Open the main circuit breaker in order to de-energize the main circuit.
- If necessary, check the de-energized status by using Voltage test meter.
- Discharge the remaining current from the capacitor to earth after 2 minute period has elapsed after isolation for safety.
- To prevent mis-operation, you need to lock the breaker that is disconnected in the “OFF” position and post a warning sign “MEN AT WORK”.



### CAUTION

Without power interruption from distribution transformer secondary side, do not remove the insulation cover surrounded by main incoming busbar.

#### 9.3.2 General safety procedures

It is mandatory to have the cooperation of related personnel for the safety of humans and equipment. Therefore, it is expected that the person working in the plant area will follow the safety regulations outlined in this procedure.

Before commencing any tests, commissioning, or operation activities the following general conditions shall be applied.

It is necessary for the operator to understand the construction of equipment and operation methods for safety.

- The working area shall be clear and free from debris and left over materials.
- Access to all working areas and equipment shall be clear.
- Ventilation system shall be satisfactory.
- Danger/warning signs as applicable shall be posted.
- Entry to the working/operation area shall be restricted to authorized persons only.
- Firefighting facilities shall be available where applicable.
- Check strict and accurate communication with relative quarters.
- Ensure equipment is de-energized (electrically isolated). The circuit diagram should be checked to see if the primary power is alive or not. Also, it is required to check the grounding to test equipment, and then check the de-energized status by using the Test meter. To ensure maximum security, all energized zones shall be kept locked. Key will be stored in the control of the responsible person as designated in this document.

## 9. INSPECTION & MAINTENANCE

### 9.4 Repair of Surface Damage

Repair of surface damage;

- Carry out repair work immediately after a defect has been discovered.
- Completely remove all rust from damaged paintwork areas on steel sheet and other steel parts by mechanical means (example: with a wire brush).
- Lightly grind the surrounding paint coat and carefully degrease the entire area. Then apply an anti-rust primer immediately, and leave it until hardened. Finally, apply the top coat. Only use suitable and compatible paint products.
- Apply the top coat in standard RAL 7032 color, or the relevant special color.

### 9.5 Table of Scheduled Maintenance

Items to be checked	Check contents & Interval (1 time)				Remarks
	Visual	Operating (Adjusting)	Measuring (Megger)	Replace	
Switch board	2 months				
Vacuum Circuit Breaker	2 months	1 year	2 year	According to its instruction manual	
Voltage transformer	2 months		2 year	Depend on megger value	
Current Transformer	2 months		2 year	Depend on megger value	
Push Button Switch	2 months	1 year		250,000 times	
Fuses	2 months				
Fluorescent Lamp	2 months	1 year			
Instrumentation parts	2 months	1 year			

# INSPECTION & MAINTENANCE

## 9. INSPECTION & MAINTENANCE

### 9.6 Preventive Maintenance Procedures of Various Equipment

#### 9.6.1 Switch board

No.	Items	Interval (1 time)	Inspection Method	Remarks
1	Rust, damage	2 months	1) Any rust, damage on metal part? 2) Any rust, damage on metal fixtures? 3) Any damage on peep hole, waterproof rubber, etc.	1) Clean the parts with damage. Repair when metal parts are damaged. 2) Clean the rust from hinges, handle, etc. because this is the cause of malfunctions. 3) Clean the inside and outside of the peep hole.
2	Imperfect function	Do.	Any fault in door, handle, latch, hinge, etc.	Repair the damaged parts.
3	Display	Do.	Any missing lamps, display or unclear?	
4	Lock device	Do.	Any abnormality in lock device?	Check the function of the locking device, etc. and confirm the key storage.

#### 9.6.2 Vacuum Circuit Breaker and Electromagnetic Contactor

※ **Note:**

See Manufacturer's Operation & Maintenance Manual for Detail

## 9. INSPECTION & MAINTENANCE

### 9.6 Preventive Maintenance Procedures of Various Equipment

No.	Items	Interval (1 time)	Inspection Method	Remarks
1	Switch operation	1 year	<p>Operate the switch several times and check the following points.</p> <ol style="list-style-type: none"> <li>1) Any fault with on and off time. Any variation?</li> <li>2) Any abnormal noise?</li> <li>3) Any abnormal vibration?</li> <li>4) Normal ON control voltage and pressure for power operation</li> <li>5) Is trip circuit normal?</li> </ol>	<ol style="list-style-type: none"> <li>1) Listen to the sound as it goes on and off. If there is any abnormality, perform a precise inspection.</li> <li>2) Perform a precise inspection for any faults other than the characteristic noise and vibration of the breaker.</li> <li>3) Pay attention to spark noise due to loose terminals, vibration due to poor fixing of the breaker, etc.</li> <li>4) Measure the control voltage and adjust the voltage of the power supply (battery, etc.) if it does not stand <math>\pm 5\%</math> of the rated value.</li> <li>5) Perform an automatic trip test with the protection relay contact circuit. It's OK if it trips.</li> </ol>
2	Display unit check	2 months	Does circuit breaker display lamp match main circuit operation?	Clean the gaps between the contacts of the auxiliary switch because they easily become dirty. If it is not normal even after cleaning the display lamp. Display and auxiliary switch, check the circuit contacts, etc.
3	Loose parts	Do.	<ol style="list-style-type: none"> <li>1) Any loose terminals in the main circuit?</li> <li>2) Any looseness in auxiliary switch, control circuit terminals, control circuit parts, and their fittings?</li> <li>3) Any looseness, bend, etc. in circuit breaker bolts, nuts etc.</li> <li>4) Any looseness or missing in shutter parts such as shutter shaft, and fasteners.</li> </ol>	<ol style="list-style-type: none"> <li>2) 3) 4) make sure no missing parts and all parts to be tightened.</li> </ol>

# INSPECTION & MAINTENANCE

## 9. INSPECTION & MAINTENANCE

### 9.6 Preventive Maintenance Procedures of Various Equipment

No.	Items	Interval (1 time)	Inspection Method	Remarks
4	Deformation	2 months	Any deformation of bus high and main circuit conductor by electromagnetic force when there is large current cut-off?	<p>Check deformation of the inside when short circuit occurs.</p> <p>Replace parts, and perform a precise examination depending on the degree of deformation at the same time.</p> <p>The circuit breaker may have to be replaced.</p>
5	Damage	Do.	<p>1) Dose the abrasion between the main contactor and housing exceed the limit?</p> <p>2) Any damage or deformation on the spring of contactor?</p>	<p>1) The limit of the abrasion between main contactor and housing by the cut-off current and cut-off circuit.</p> <p>Refer to the manufacturer's instruction manual and repair or replace them and perform a precise examination.</p> <p>2) If there is damage or deformation on the contacts or spring, replace and perform a precise examination.</p>
6	Insulation resistance	2 years.	<p>With insulation resistance meter (megger).</p> <p>* High voltage circuit : 1000V or more</p> <p>* Low voltage circuit : 500V</p> <p>after cleaning the insulator and insulation material with a dry cloth.</p>	<p>Use the following as a guide for insulation resistance between the main circuit and the ground.</p> <p>Between the contacts of same phase of main circuit(100M ohm).</p> <p>Between the main circuits of different phase</p> <p>Between the control unit conductor and ground (1M ohm)</p>

## 9. INSPECTION & MAINTENANCE

### 9.6 Preventive Maintenance Procedures of Various Equipment

#### 9.6.3 Voltage Transformer (VT) & Current Transformer (CT)

No.	Items	Interval (1 time)	Inspection Method	Remarks
1	External deformation	2 months	<ol style="list-style-type: none"> <li>1) Any internal abnormality or swelling or cracks in rubber, compound, resin, etc. due to excessive heat of primary terminals?</li> <li>2) Any traces of electric discharge affected by dirt and moisture, salt, gas, etc for long time.</li> </ol>	<ol style="list-style-type: none"> <li>1) Do not reuse damaged equipment badly affected by external shock or internal malfunction. After replacing, remove the cause of the trouble such as load, wiring, etc. before operating.</li> <li>2) Replace deformed equipment showing traces of electric discharge. Carefully check the surrounding conditions, etc., to see that it doesn't happen again.</li> </ol>
2	Dirty, damage	Do.	<ol style="list-style-type: none"> <li>1) Any dirt, damage, etc.?</li> <li>2) Is fuse OK?</li> <li>3) Anything sticking to conductors, core fittings, bolts, nuts, etc., any damage to them, any of them missing, any cracks, etc.?</li> </ol>	<ol style="list-style-type: none"> <li>1) Clean because dirt may become the cause of discharge. Check for cracks while cleaning and replace anything damaged.</li> <li>2) Be careful with poor fuse contact in a high voltage circuit because it may be the cause of different phase flashover accompanied by electric discharge.</li> </ol>
3	Heat discoloration	Do.	Any discoloration of conductors due to excessive heat?	Perform a precise examination when there is heat discoloration on the conductor.
4	Rust	Do.	Any rust on conductors?	Clean when there is rust on the conductors, core, and structure and repair the painted parts.
5	Looseness	Do.	<ol style="list-style-type: none"> <li>1) Any looseness of primary and secondary terminal fittings?</li> <li>2) And looseness in mounting bolts?</li> </ol>	<p>Be careful because looseness of the primary and secondary terminals may cause accidents.</p> <p>Tighten the mounting bolts, etc.</p>
6	Insulation resistance	2 years.	<ol style="list-style-type: none"> <li>3) Any looseness in fuse mountings?</li> </ol> <p>With an insulation resistance meter (megger) exceeding 1000V.</p> <p>Do after cleaning the insulation material with a dry cloth.</p>	<p>Use the following guide for insulation resistance.</p> <p>Between the primary line and the secondary line (30 Megger ohm)</p> <p>Between the secondary line and the outside box (2 Megger ohm)</p>

# INSPECTION & MAINTENANCE

## 9. INSPECTION & MAINTENANCE

### 9.6 Preventive Maintenance Procedures of Various Equipment

#### 9.6.4 Switch, Contactor

No.	Items	Interval (1 time)	Inspection Method	Remarks
1	Switch operation check	1 year	Any abnormality when operating several times?	Check the condition of the contactors and mechanism in response to manual operation.
2	Heat discoloration	2 months	Any discoloration of contacts?	Replace if there is discoloration in the switch and contacts.
3	Abnormal smell	Do.	Any rust on conductors, metal fittings, mounting fixtures?	When there is an abnormal smell, check the built-in coil bush, insulation material and other hidden parts.
4	Rust	Do.	Any rust on conductors, metal fittings, mounting fixtures?	Aluminum, copper, etc., are easily rusted and corroded by moisture and gas. Cleaning is required during inspection
5	Contact	Do.	1) Any fault in contact pressure due to spring fatigue, copper plating, etc. 2) Any abnormality due to wear in contact points, contact deformation.	1) With a self-contacting type, lightly tap the conductor part to check if there is any fault in the elasticity comparing that sound with the metallic sound of a good contact. 2) Replace any worn contacts.
6	Looseness	Do.	Any loose bolts, nuts in moving parts, conductor connections, etc.	Securely tighten any loose ones

## 9. INSPECTION & MAINTENANCE

### 9.6 Preventive Maintenance Procedures of Various Equipment

#### 9.6.5 Busbar

No.	Items	Interval (1 time)	Inspection Method	Remarks
1	Heat discoloration	2 months	Any discoloration in auxiliary busbar, insulated busbar?	If there is discoloration in the busbar, check whether the load current is too large for the current capacity of the busbar.
2	Dirty / foreign matter	Do.	Any dust or foreign matter in all busbar.	Busbar must be kept in a clean environment, it is necessary to clean in a no-voltage condition.
3	Contact looseness	Do.	Any looseness in contacts of clamps, mounting bolts etc.	Loose busbar contacts are the cause of accidents such as fusing due to busbar current. Be sure to check when there is a chance with no-voltage

# TREATMENT

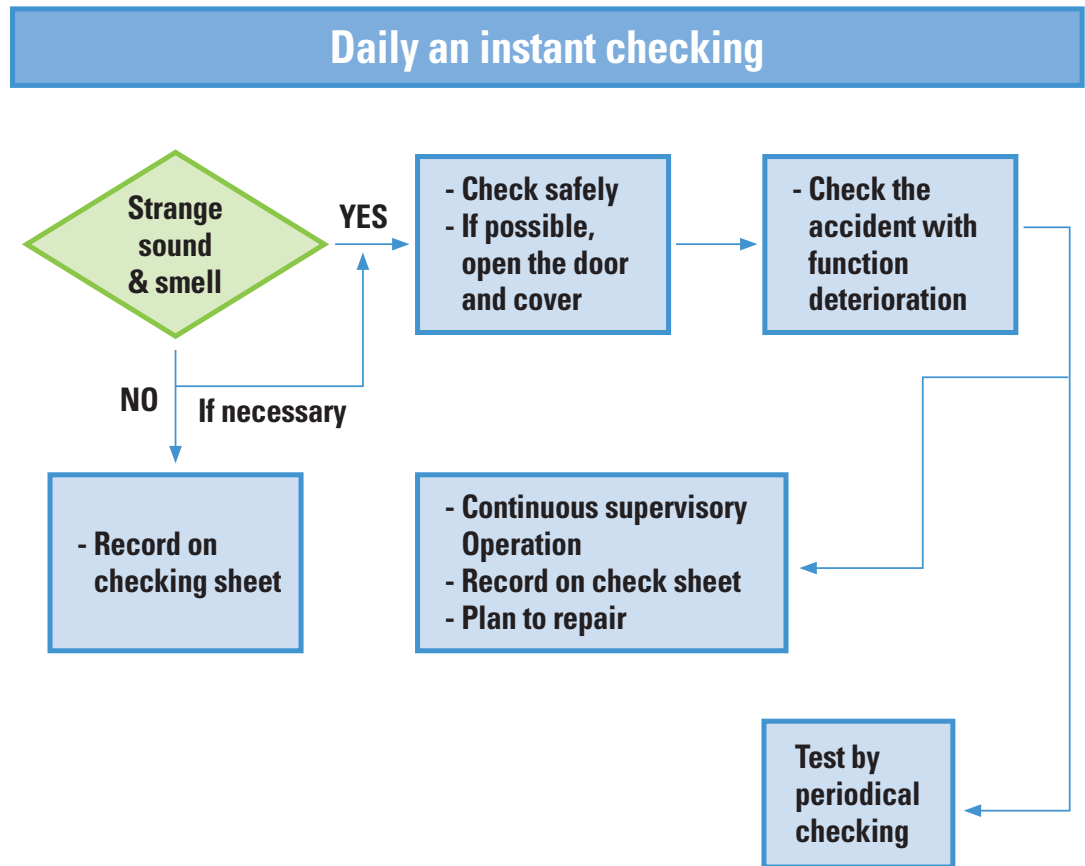

## 10. TREATMENT

### 10.1 Daily and Instant Treatment

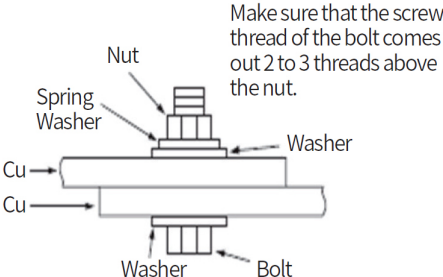

## 10. TREATMENT

### 10.2 Periodical Treatment

No.	Treatment	Contents and Attention
1	Cleaning	<p>1) It is recommended to use attraction method in case of using the air or ejecting method.</p> <p>※ Be aware of humidity and pressure of air.</p> <p>2) Before opening the door and cover, clean the dust and other dirt.</p> <p>3) Clean the insulation material in cross direction between the live parts.</p> <p>4) It is recommended to use neutral cleaning materials.</p>
2	Bolt joint (busbar, construction)	<p>A. JOINT OF BUSBAR CONNECTION</p> <p>1) Method</p> <ol style="list-style-type: none"> <li>Joint with proper torque wrench with adequate torque.</li> <li>Joint to turn the nut, not bolt.</li> <li>Be cautious of not tightening one side only, if using more than 2 bolts.</li> </ol> <div style="text-align: center;">  </div> <p>B. CHECKING OF BOLT JOINTING</p> <p>It is necessary to check whether the bolt is jointed with defined torque because incomplete jointing of bolt may cause a huge accident. Therefore, Bolts and nuts are necessary to be marked in red after the joint works.</p> <p>※ BOLT joint torque shall follow in accordance with Table A.</p> <div style="text-align: center;">  </div>

# TREATMENT

## 10. TREATMENT

### 10.2 Periodical Treatment

No.	Treatment	Contents and Attention																																
3	Repair of insulation Materials	<p>1) When the porcelain insulator is polluted by dust, clean it by referring to the Treatment above.</p> <p>2) When the looseness occurs due to the worn-out resin or wooden materials, then change the part by referring to Treatment 5.</p> <p>3) Damage, crack, and variation of insulation material require replacement too.</p> <p>4) The dropping of insulation resistance requires checking the table below. Then compare and check with previous data, and treat adequately.</p> <p>5) The value of insulation resistance may be influenced by temperature, humidity, and surface condition. Therefore it is difficult to decide the quality, but refer to the following values.</p> <p>a) Panel</p> <ul style="list-style-type: none"> <li>- Condition: 68°F(20°C) 65% RH</li> <li>- High-voltage circuit: More 5M Ohm</li> <li>- Low voltage circuit:</li> </ul> <table border="1" style="margin-left: 20px;"> <thead> <tr> <th colspan="2">Voltage class</th> <th>insulation Resistance value</th> </tr> </thead> <tbody> <tr> <td rowspan="2">Below 300V</td> <td>voltage to earth Below 300V</td> <td>0.1 M ohm</td> </tr> <tr> <td>Others</td> <td>0.2 M ohm</td> </tr> <tr> <td colspan="2">330V ~ 600V</td> <td>0.4 M ohm</td> </tr> </tbody> </table> <p>b) Main circuit breaker and isolator</p> <table border="1" style="margin-left: 20px;"> <thead> <tr> <th></th> <th>insulation Resistance value</th> <th>Tester</th> </tr> </thead> <tbody> <tr> <td>Main circuit</td> <td>More 500M ohm</td> <td>1000V</td> </tr> <tr> <td>Control circuit</td> <td>More 2M ohm</td> <td>500V</td> </tr> </tbody> </table> <p>c) Measuring instrument</p> <table border="1" style="margin-left: 20px;"> <thead> <tr> <th>Base temp</th> <th>20°C</th> <th>30°C</th> <th>40°C</th> </tr> </thead> <tbody> <tr> <td>- Enclosure - Between primary and secondary winding</td> <td>500M ohm</td> <td>250M ohm</td> <td>130M ohm</td> </tr> <tr> <td>- Between enclosure and secondary winding</td> <td colspan="3">2M ohm</td> </tr> </tbody> </table>	Voltage class		insulation Resistance value	Below 300V	voltage to earth Below 300V	0.1 M ohm	Others	0.2 M ohm	330V ~ 600V		0.4 M ohm		insulation Resistance value	Tester	Main circuit	More 500M ohm	1000V	Control circuit	More 2M ohm	500V	Base temp	20°C	30°C	40°C	- Enclosure - Between primary and secondary winding	500M ohm	250M ohm	130M ohm	- Between enclosure and secondary winding	2M ohm		
Voltage class		insulation Resistance value																																
Below 300V	voltage to earth Below 300V	0.1 M ohm																																
	Others	0.2 M ohm																																
330V ~ 600V		0.4 M ohm																																
	insulation Resistance value	Tester																																
Main circuit	More 500M ohm	1000V																																
Control circuit	More 2M ohm	500V																																
Base temp	20°C	30°C	40°C																															
- Enclosure - Between primary and secondary winding	500M ohm	250M ohm	130M ohm																															
- Between enclosure and secondary winding	2M ohm																																	

## 10. TREATMENT

### 10.2 Periodical Treatment

No.	Treatment	Contents and Attention			
4		- Mold Type -			
		Base temp	20°C	30°C	40°C
		- Enclosure - Between primary and secondary windings	200M ohm	100M ohm	50M ohm
	- Between enclosure and secondary 2M ohm windings	2M ohm			
5	replacing parts	1) Check the type and function. 2) During the change of parts, make sure that misconnection does not occur, and follow the instruction of tightening bolts and torques 3) If the adjustment is necessary, set the value properly after the change is done. 4) In case of welding, make sure skilled personnel do the job.			

# Memo

---

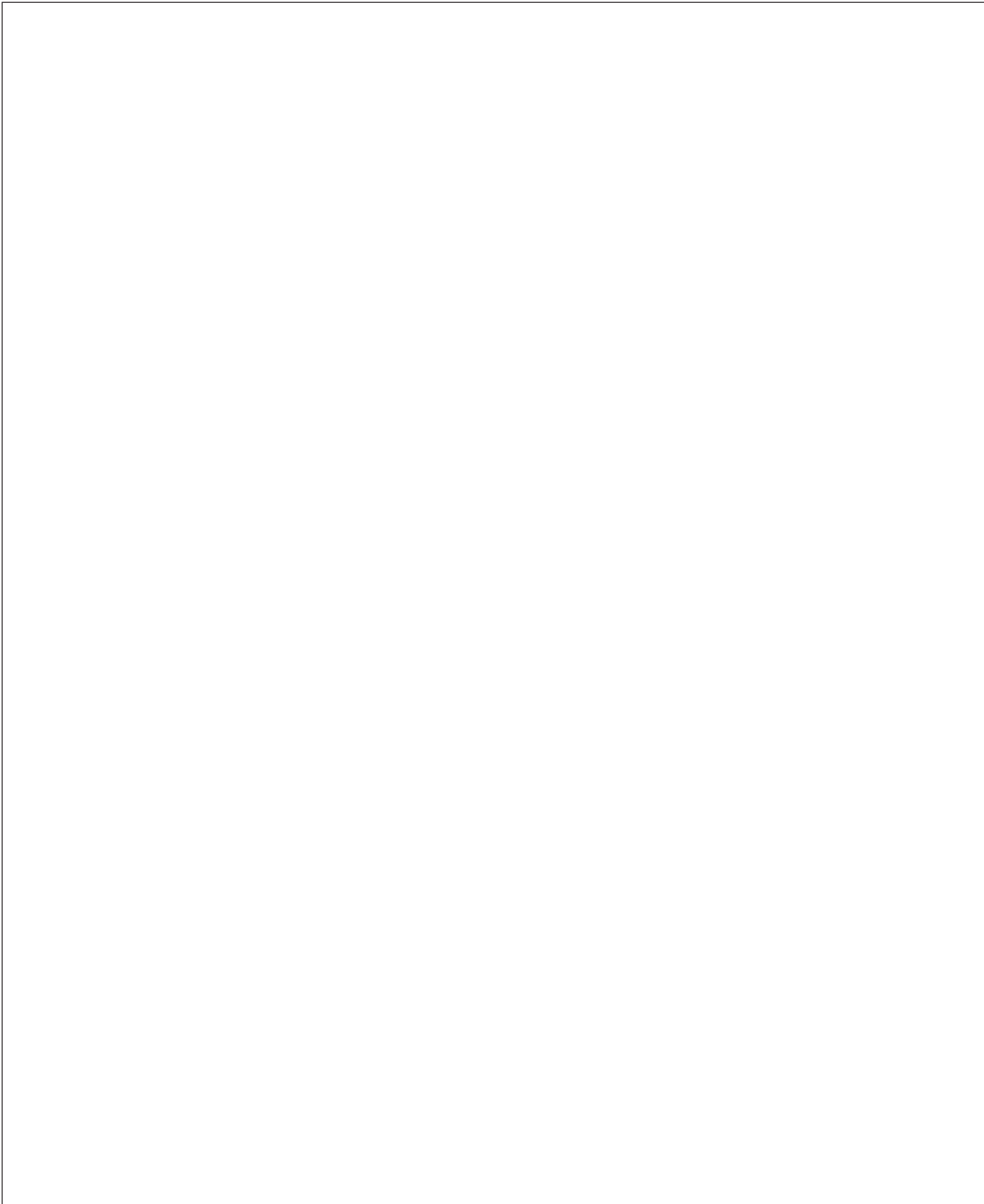



### LS ELECTRIC America Inc. Chicago Head Office

625 Heathrow Dr, Lincolnshire, IL 60069, USA

Tel: 1-224-352-2265 E-Mail: sales.us@lselectricamerica.com

### Headquarter

127 LS-ro (Hogye-dong) Dongan-gu, Anyang-si, Gyeonggi-Do, 14119, Korea

### Seoul Office

LS Yongsan Tower, 92, Hangang-daero, Yongsan-gu, Seoul, 04386, Korea

TEL: 82-2-2034-4916, 4684, 4429

### China

LS ELECTRIC (Dalian) Co., Ltd.

+86-411-8730-7560

china.dalian@lselectric.com.cn

LS ELECTRIC (Wuxi) Co., Ltd.

+86-510-8534-6666

china.wuxi@lselectric.com.cn

LS ELECTRIC (Lishui) Co., Ltd.

+86-133-6207-7980

china.lishui@lselectric.com.cn

Shanghai Office

+86-21-5237-9977

china@lselectric.com.cn

Beijing Office

+86-10-5095-1631

china@lselectric.com.cn

Guangzhou Office

+86-20-3818-2883

china@lselectric.com.cn

Qingdao Office

+86-532-8501-2065

china@lselectric.com.cn

Chengdu Office

+86-28-8670-3201

china@lselectric.com.cn

Nanjing Office

+86-25-8467-0005

china@lselectric.com.cn

### India

India Office

+91-80-6142-9108

Info\_india@ls-electric.com

### Indonesia

PT. LS ELECTRIC INDONESIA

+62-21-2933-7614

indonesia@ls-electric.com

PT SYMPHOS ELECTRIC

+62-81-1900-1474

marketing@symphos-weltraf.com

### Italy

Italy office

+39-030-8081-833

italia@ls-electric.com

### Japan

LS ELECTRIC Japan Co., Ltd.

+81-3-6268-8241

japan@ls-electric.com

Tokyo Office

+81-3-6268-8241

tokyo@ls-electric.com

### Netherlands

LS ELECTRIC Europe B.V.

+31-20-654-1424

europartner@ls-electric.com

### Russia

Moscow Office

+7-499-682-6130

info@lselectric-ru.com

### Singapore

Singapore Office

+65-6958-8162

singapore@ls-electric.com

### Spain

LS ELECTRIC IBERIA S.L.U.

+34-910-28-02-74

iberia@ls-electric.com

### Thailand

Bangkok Office

+66-2-128-0295

thailand@ls-electric.com

### Türkiye

LS ELECTRIC Türkiye Co., Ltd.

+90-212-806-1252

turkiye@ls-electric.com

### U.A.E

LS ELECTRIC Middle East FZE (Dubai)

+971-4-886-5360

middleeast@ls-electric.com

### USA

LS ELECTRIC America Inc.

+1-800-891-2941

sales.us@lselectricamerica.com

LS ENERGY SOLUTIONS LLC

+1-980-221-0654

cmfeldman@ls-es.com

MCM Engineering II

+1-435-865-0125

sales.us@lselectricamerica.com

America Western Office

+1-949-333-3140

america@ls-electric.com

America Bastrop Campus

+1-224-352-2265

sales.us@lselectricamerica.com

### Vietnam

LS ELECTRIC Vietnam Co., Ltd.

+84-222-2221-110

vietnam@ls-electric.com

Hanoi Sales Office

+84-24-6275-8054

vietnam@ls-electric.com

Ho Chi Minh Sales Office

+84-3823-7890

vietnam@ls-electric.com

Specifications in this catalog are subject to change without notice due to continuous product development and improvement

© 2024. 5 LS ELECTRIC Co., Ltd. All rights reserved. / English (01) 2024. 05 Staffcom

[www.LSElectricAmerica.com](http://www.LSElectricAmerica.com)