



Beyond X™

Susol UL VCB

UL Vacuum Circuit Breakers



LS ELECTRIC





Susol *Super Solution*

Vacuum Circuit Breaker

Contents

• Overview	04
• External structure of VCB	08
• Overview of Susol VCB	10
• UVL Fixed type	11
• UVM Fixed type	17
• UVH Fixed type	29
• UVL Draw-out type	41
• UVM Draw-out type	55
• UVH Draw-out type	85
• UVGT (Ground and Test device)	141
• UCGT (Ground and Test device)	147
• Accessories	163
• VCB remote control circuit	197
• Technical data	203

Susol VCB

The Vacuum Circuit Breaker (VCB) is designed for medium voltage distribution line installations. This solution protects systems and equipment from abnormal current (overcurrent, short circuit or ground fault). In application, a separate external relay sends a signal to the vacuum interrupter located inside the VCB to break the circuit, protecting connected loads and increasing workplace safety.

Susol VCB solutions

- Actively meets customers' need for breakers with high interrupting capacity and large current due to integration and increase of load capacity.
- Leads worldwide trend of diversification in medium voltage distribution lines.
- Increased reliability of the circuit breaker's temperature characteristics for durability in industrial and commercial sites.

Premium products that improve convenience of medium voltage switchgear configuration.

- Full line-up with models consisting of high interrupting capacities and large current ratings.
- Serves as a main structure with reliable application.
- A variety of accessories are available, meeting a wide range of project or system requirements.

Susol VCBs are suitable for use as the main circuit breaker to protect key installations in device industries, power plants, commercial buildings, marine sites and vessels, transportation infrastructure, substations and large-scale power distribution.



▶ Full line-up of high/middle/low VCB models.

Voltage	Interrupting current	Rated current
4.76/15kV	25/31.5/40/50kA	1200/2000/3000/4000A
27kV	25/31.5/40kA	1200/2000/2500/2750A
38kV	31.5/40kA	1200/2000/3000A

▶ Main circuit structure with high reliability.

- Maximized the durability and reliability of the main circuit contactors.
- Strong structure for the temperature rise (Natural cooling system).

▶ Convenience of switchgear configuration and a variety of accessories.



- CB compartment: Metal isolation is implemented to minimize damage and ensure safety. The convenience of switchgear design is achieved by its modular style.
- A variety of accessories: UVT, Plug Interlock, Key lock, Temperature Sensor, MOC, TOC.
- Maximizing compatibility with existing products through the dualistic deployment of phases and compact models.

※ Type testing is complete for all models according to latest standard, IEEE Std C37.09, IEEE Std C37.20.2, ANSI C37.54, ANSI C37.55

Rated voltage	4.76/15kV				27kV			38kV		
	Isc[kA]	25	31.5	40	50	25	31.5	40	31.5	40
1200										
2000										
2500										
2750										
3000										
4000										

□ : UL certificated
 ⊗ : Not developed

Among the UL certificated product

Fixed type	Draw-out type
	



CB Compartment

Convenience in building switchgears

- CB compartment structure: H type cradle
- Metal isolation is implemented to minimize damage and ensure safety
- Easy switchgear build



4.76/15/27/38kV 25/31.5/40/50kA

- Metal isolation is implemented to minimize damage and ensure safety.
- Convenience of operation by racking device in SWGR
 - Operator is able to withdraw CB without door open
 - Mechanically CB position indicator on the front side of SWGR
- Equipped with safety devices and accessories
 - Metallic shutter
 - Door interlock
 - Motorized racking system (4.76/15/27kV UVM/UVH Only)
 - Key lock on racking operation
 - Auto-connection of control wiring
- Convenience assembly of switchgear
 - Module structure enhance productivity





Circuit breaker compartment accessories (H type Cradle)

- MOC (Mechanism Operated Cell S/W)
- TOC (Truck Operated Cell S/W)
- Shutter padlock
- Key interlock (Kirk key)

UVL/UVM type

Front side

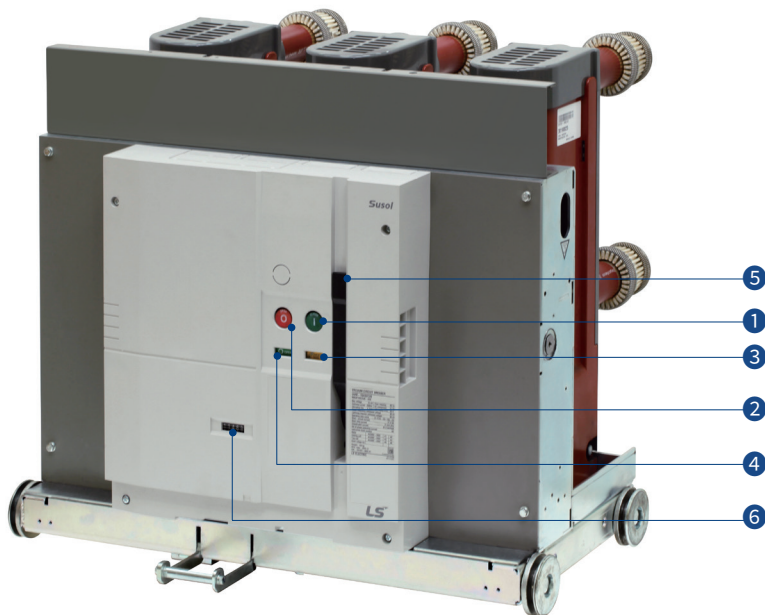

- ① CLOSE Button
- ② OPEN Button
- ③ Charge/Discharge Indicator
- ④ CLOSED/OPEN Indicator
- ⑤ Manual Charging Handle
- ⑥ Operation Counter

Back side



Front side

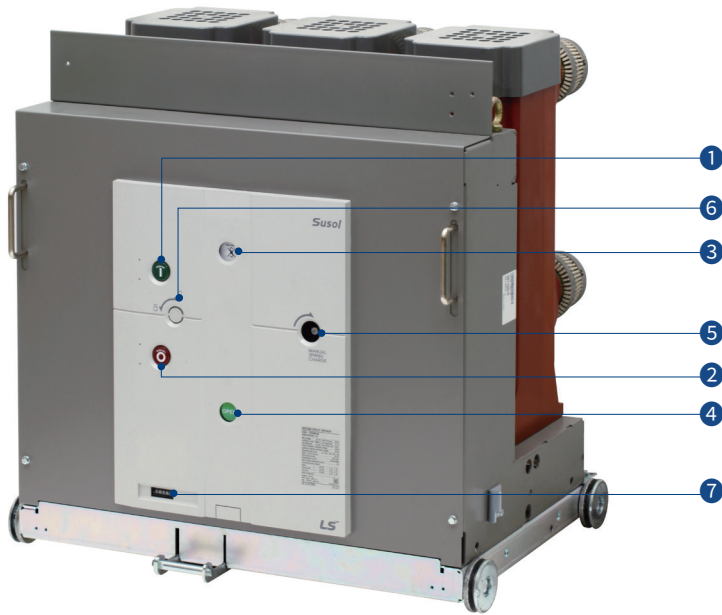

- ① CLOSE Button
- ② OPEN Button
- ③ Charge/Discharge Indicator
- ④ CLOSED/OPEN Indicator
- ⑤ Manual Charging Handle
- ⑥ Key Lock
- ⑦ Operation Counter

Back side





Susol VCB

VCB ratings

Rated voltage	4.76kV				15kV				27kV			38kV		
	Isc [kA]	25	31.5	40	50	25	31.5	40	50	25	31.5	40	31.5	40
1200	Ir [A]	25	31.5	40	50	25	31.5	40	50	25	31.5	40	31.5	40
1200		UVL/UVM-05/15	UVL/UVM-05/15	UVH-05/15	UVH-05/15	UVL/UVM-05/15	UVL/UVM-05/15	UVH-05/15	UVH-05/15	UVM-27	UVH-27	UVH-27	UVH-38	UVH-38
2000		UVL/UVM-05/15	UVL/UVM-05/15	UVH-05/15	UVH-05/15	UVL/UVM-05/15	UVL/UVM-05/15	UVH-05/15	UVH-05/15	UVM-27	UVH-27	UVH-27	UVH-38	UVH-38
2500		Not developed	Not developed	Not developed	Not developed	Not developed	Not developed	Not developed	Not developed	UVH-27	UVH-27	UVH-27	Not developed	Not developed
2750		Not developed	Not developed	Not developed	Not developed	Not developed	Not developed	Not developed	Not developed	UVH-27	UVH-27	UVH-27	Not developed	Not developed
3000		UVH-05/15	UVH-05/15	UVH-05/15	UVH-05/15	UVH-05/15	UVH-05/15	UVH-05/15	UVH-05/15	Not developed	Not developed	Not developed	UVH-38	UVH-38
4000		UVH-05/15	UVH-05/15	UVH-05/15	UVH-05/15	UVH-05/15	UVH-05/15	UVH-05/15	UVH-05/15	Not developed	Not developed	Not developed	Not developed	Not developed

- : UVL/UVM-05/15 UL certified
- : UVM-27 UL certified
- : UVH-05/15 UL certified
- : UVH-27 UL certified
- : UVH-38 UL certified
- : Not developed

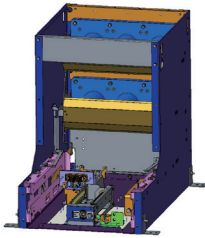
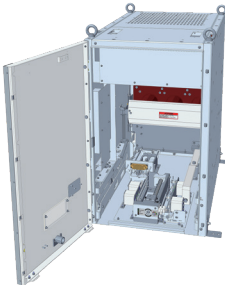
VCB and cradle configuration

Type	Fixed	Draw-out		
Cradle	-	L	C	H
Appearance				
CB type	<ul style="list-style-type: none"> • UVL-05/15 • UVM-05/15/27 • UVH-05/15/27/38 	<ul style="list-style-type: none"> • UVL-05/15 • UVM-05/15/27 • UVH-05/15/27 	<ul style="list-style-type: none"> • UVM-05/15/27 • UVH-05/15/27 	<ul style="list-style-type: none"> • UVM-05/15/27 • UVH-05/15/27/38
Description	<ul style="list-style-type: none"> • No cradle, Fixed 	<ul style="list-style-type: none"> • Economy cradle for MCSG 	<ul style="list-style-type: none"> • Compact CB compactment • Shorter depth than H type 	<ul style="list-style-type: none"> • H type CB Compartment

Susol UVL

Fixed type



Contents

▪ Ratings and description	12
▪ Selection guide	13
▪ Order form	14
▪ Dimensions	15

Ratings and description

UVL type, Fixed type

UVL-05P / UVL-15P 

Circuit breaker type		UVL-05P				UVL-15P			
Rated voltage	Ur (kV)	4.76				15			
Rated withstand voltage	Power frequency (1min)	19				36			
	Lightening impulse (1.2×50µs)	60				95			
Rated short-circuit current	Isc (kA)	25	31.5		25	31.5			
Rated normal current	Ir (A)	1200	2000	1200	2000	1200	2000	1200	2000
Rated frequency	fr (Hz)	60	60	60	60	60	60	60	60
Rated short-circuit making current	Ip (kA) at 60 Hz	65	65	81.9	81.9	65	65	81.9	81.9
Rated short-time withstand current	Ik (kA)	25	25	31.5	31.5	25	25	31.5	31.5
	3sec	●	●	●	●	●	●	●	●
Operating sequence	O - 0.3s - CO - 15s - CO	●	●	●	●	●	●	●	●

Technical data

Opening time		Less than 0.04 sec
Rated breaking time		3 Cycle
No-load closing time		Less than 0.06 sec
Test class	Mechanical endurance	M2 (10,000)
	Electrical endurance	Reference standard (page 210)
	Capacitance	C2
Operating temperature	Low	-40 °C
	High	40 °C

Description for circuit breaker type

UVL type, Fixed type

UVL	15	P	32	A	12
Model	Rated voltage (kV)	Type	Interrupting current (kA)	Phase distance	Rated current (A)
UVL Susol VCB	05 4.76 15 15	P Fixed Type	25 25 32 31.5	A 5.9in(150mm)	12 1200 20 2000

Selection table of circuit breaker type

Ur [kV]	Isc [kA]	Ir [A] p = 5.9"	Circuit breaker Model	Weight [lb]	Outline dimension H×W×D [in]	Dimension page
4.76	25	1200	UVL-05P25A12	187.4	26.4×23.2×20	15
		2000	UVL-05P25A20	220.5	26.4×23.2×20.6	16
	31.5	1200	UVL-05P32A12	187.4	26.4×23.2×20	15
		2000	UVL-05P32A20	220.5	26.4×23.2×20.6	16
15	25	1200	UVL-15P25A12	187.4	26.4×23.2×20	15
		2000	UVL-15P25A20	220.5	26.4×23.2×20.6	16
	31.5	1200	UVL-15P32A12	187.4	26.4×23.2×20	15
		2000	UVL-15P32A20	220.5	26.4×23.2×20.6	16

Order form

Full description for circuit breaker

UVL type, Fixed type

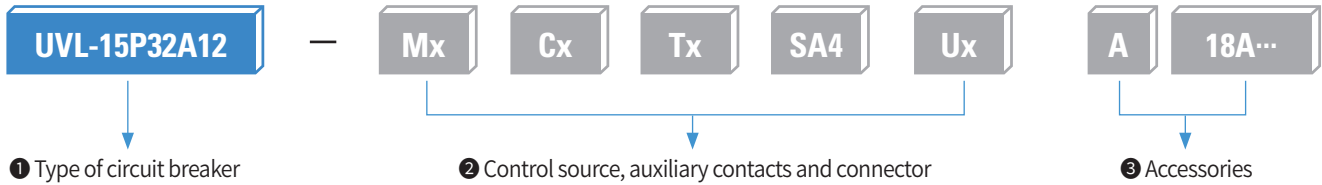

① Type of circuit breaker
(select from the previous page)

② Control source, auxiliary contacts and connector

③ Accessories

※ In case of selecting ③ Accessories, only type Symbol 'A' once. (ex. A18A)

Order form for circuit breaker

Please select only one item per line. (* Required selection)

UVL, VCB, Fixed type

(no extra charge extra charge)

① Type of VCB from selection table*		Quantity	ea
② Accessories			
Motor* (Mx)			page 164
<input type="radio"/> M2	<input type="radio"/> M3	<input type="radio"/> M4	<input type="radio"/> M5
DC 200V ~ 250V	DC 125V	DC 24V ~ 30V	DC 48V ~ 60V
<input type="radio"/> M6	<input type="radio"/> M7	<input type="radio"/> M8	
AC 48V	AC 100V ~ 130V	AC 200V ~ 250V	
Closing coil* (Cx)			page 165
<input type="radio"/> C2	<input type="radio"/> C3	<input type="radio"/> C4	<input type="radio"/> C5
DC 200V ~ 250V	DC 125V	DC 24V ~ 30V	DC 48V ~ 60V
<input type="radio"/> C6	<input type="radio"/> C7	<input type="radio"/> C8	
AC 48V	AC 100V ~ 130V	AC 200V ~ 250V	
Shunt trip coil* (Tx)			page 164
<input type="radio"/> T2	<input type="radio"/> T3	<input type="radio"/> T4	<input type="radio"/> T5
DC 200V ~ 250V	DC 125V	DC 24V ~ 30V	DC 48V ~ 60V
<input type="radio"/> T6	<input type="radio"/> T7	<input type="radio"/> T8	
AC 48V	AC 100V ~ 130V	AC 200V ~ 250V	
Auxiliary contacts & Connector type*			page 169
<input type="radio"/> SA2(4a4b, A-type)	<input type="radio"/> SA4(10a10b, A-type)	<input type="radio"/> SQ2(4a4b, Q-type)	<input type="radio"/> SQ4(10a10b, Q-type)
Under voltage release (Ux)			page 170
<input type="radio"/> U0	<input type="checkbox"/> U2	<input type="checkbox"/> U3	<input type="checkbox"/> U4
Without UVT	DC 200V ~ 250V	DC 125V	DC 24V ~ 30V
<input type="checkbox"/> U5	<input type="checkbox"/> U6	<input type="checkbox"/> U7	<input type="checkbox"/> U8
DC 48V ~ 60V	AC 48V	AC 100V ~ 130V	AC 200V ~ 250V
※ Even without UVT, U0 must be selected to make VCB ordering code and description			
Note) 1. In case of DC24V control source(M4, C4, T4, U4), it is recommended to be used through Rated Control Voltage. 2. SB2 and SB4 have been updated to SQ2 and SQ4. If you need the SB type, please contact your sales person or customer representative.			
Combination table			page 167
U0	1		
U1-8		1	
A1 & A2	1		
Auxiliary contact			
Symbol	10a10b		
Standard	10 NO, 10 NC		
with A1	9 NO, 9 NC		
with A2	9 NO, 8 NC		
Secondary shunt trip coil			page 167
<input type="checkbox"/> A1 (Secondary shunt trip coil)	<input type="checkbox"/> A2 (Secondary shunt trip coil monitoring contact)		
※ In case of selecting A1, maximum auxiliary contacts are 9a9b		※ In case of selecting A2, maximum auxiliary contacts are 9a8b	
Keylock			page 172
<input type="checkbox"/> A7 (Keylock)	<input type="checkbox"/> AM (Kirk key, CAMLOCK type)	<input type="checkbox"/> AN (Kirk key, CN-22 type)	<input type="checkbox"/> AP (Kirk key, Double CAMLOCK type)
Button padlock			page 173
<input type="radio"/> A8 (Button padlock)	<input type="radio"/> AX (Button padlock In open)		
Lead wire*			page 174
<input type="radio"/> AA (Lead wire)	<input type="radio"/> AB (User plug)		

Accessories (Sold separately)

CTU (Coil test unit)	page 179
<input type="checkbox"/> 73873171221 CTU (Coil test unit)	
CTD (Condenser trip device)	page 180
<input type="checkbox"/> 76113143001 CTD (Condenser trip device) DC 125V	
<input type="checkbox"/> 76113143002 CTD (Condenser trip device) DC 250V	
UDC (UVT delay controller)	page 181
<input type="checkbox"/> 52773171282 UDC (UVT delay controller) AC/DC 100~130V	
<input type="checkbox"/> 52773171283 UDC (UVT delay controller) AC/DC 200~250V	
<input type="checkbox"/> 52773171281 UDC (UVT delay controller) DC 48~60V and AC 48V	

4.76kV, 25/31.5kA, 1200A

UVL type, Fixed type

Circuit breaker model

UVL-05P25A12
UVL-05P32A12

[Unit: in(mm)]

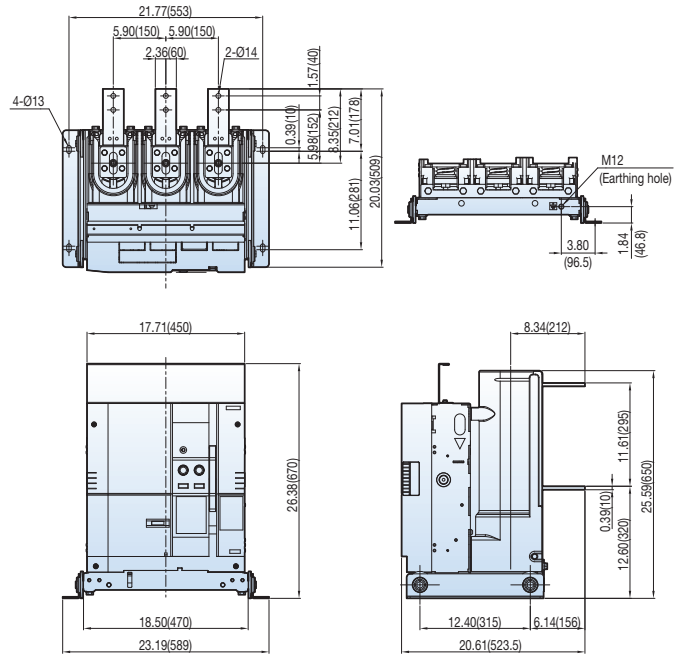

15kV, 25/31.5kA, 1200A

Circuit breaker model

UVL-15P25A12
UVL-15P32A12

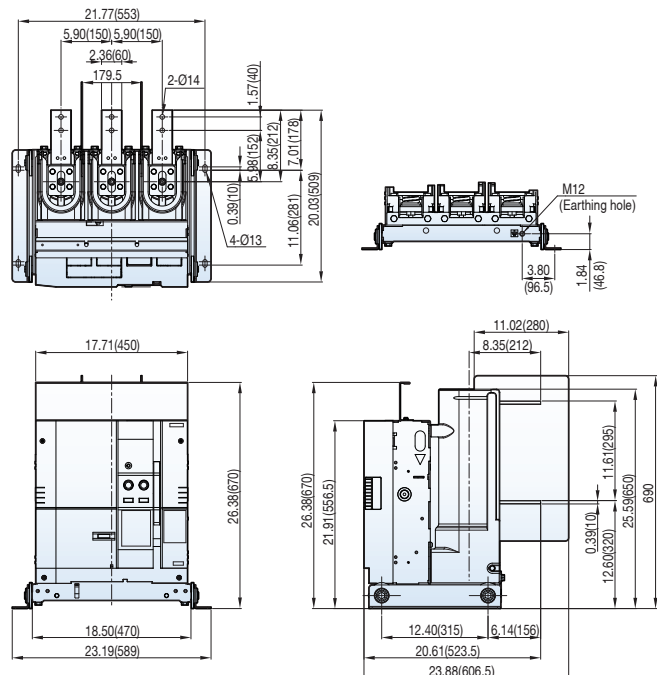

Dimensions

4.76/15kV, 25/31.5kA, 2000A

UVL type, Fixed type

Circuit breaker model

- UVL-05P25A20
- UVL-05P32A20
- UVL-15P25A20
- UVL-15P32A20

[Unit: in(mm)]

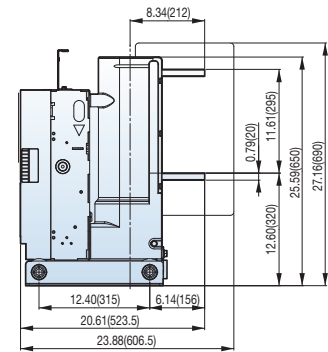
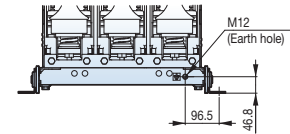
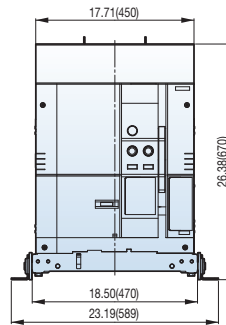
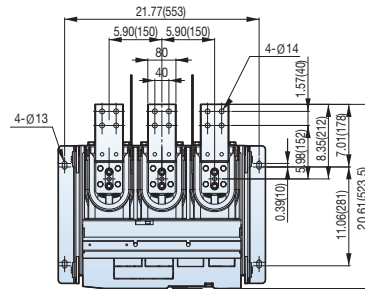

Susol UVM

Fixed type



Contents

▪ Ratings and description	18
▪ Selection guide	20
▪ Order form	21
▪ Dimensions	22

Ratings and description

UVM type, Fixed type

UVM-05P / UVM-15P  US

Circuit breaker type		UVM-05P				UVM-15P			
Rated voltage	Ur (kV)	4.76				15			
Rated withstand voltage	Power frequency (1min)	19				36			
	Lightening impulse (1.2×50µs)	60				95			
Rated short-circuit current	Isc (kA)	25	31.5		25	31.5			
Rated normal current	Ir (A)	1200	2000	1200	2000	1200	2000	1200	2000
Rated frequency	fr (Hz)	60	60	60	60	60	60	60	60
Rated short-circuit making current	Ip (kA) at 60 Hz	65	65	81.9	81.9	65	65	81.9	81.9
Rated short-time withstand current	Ik (kA)	25	25	31.5	31.5	25	25	31.5	31.5
	3sec	●	●	●	●	●	●	●	●
Operating sequence	O - 0.3s - CO - 15s - CO	●	●	●	●	●	●	●	●

Technical data

Opening time		Less than 0.04 sec
Rated breaking time		3 Cycle
No-load closing time		Less than 0.06 sec
Test class	Mechanical endurance	M2 (10,000)
	Electrical endurance	Reference standard (page 210)
	Capacitance	C2
Operating temperature	Low	-40 °C
	High	40 °C

UVM-27P  **US**

Circuit breaker type		UVM-27P	
Rated voltage	Ur (kV)	27	
Rated withstand voltage	Power frequency (1min)	Ud (kV)	60
	Lightening impulse (1.2×50μs)	Up (kV)	125
Rated short-circuit current	Isc (kA)	25	
Rated normal current	Ir (A)	1200	2000
Rated frequency	fr (Hz)	60	60
Rated short-circuit making current	Ip (kA) at 50 Hz	-	-
	Ip (kA) at 60 Hz	65	65
Rated short-time withstand current	Ik (kA)	25	25
	3sec	●	●
Operating sequence	O - 0.3s - CO - 15s - CO	●	●

Technical data

Opening time		Less than 0.04 sec
Rated breaking time		3 Cycle
No-load closing time		Less than 0.06 sec
Test class	Mechanical endurance	M2 (10,000)
	Electrical endurance	Reference standard (page 210)
	Capacitance	C2
Operating temperature	Low	-40 °C
	High	40 °C

Selection guide

Description for circuit breaker type

UVM type, Fixed type

UVM	15	P	32	A	12
Model	Rated voltage (kV)	Type	Interrupting current (kA)	Phase distance	Rated current (A)
UVM Susol VCB	05 4.76 15 15 27 27	P Fixed Type P Fixed Type	25 25 32 31.5 25 25	A 7in(178mm) C 10in(254mm) C 10in(254mm)	12 1200 20 2000 12 1200 20 2000

Selection table of circuit breaker type

Ur [kV]	Isc [kA]	Ir [A]		Circuit breaker Model	Weight [lb]	Outline dimension H×W×D [in]	Dimension page
		p = 7"	p = 10"				
4.76	25	1200 2000		UVM-05P25A12	187.4	26.4×24.8×20.6	22
				UVM-05P25A20	242.5	26.4×24.8×20.6	25
		1200 2000		UVM-05P25C12	220.5	26.4×32.2×20.6	23
	UVM-05P25C20			275.6	26.4×32.2×20.6	26	
	31.5	1200 2000		UVM-05P32A12	187.4	26.4×24.8×20.6	23
				UVM-05P32A20	242.5	26.4×24.8×20.6	25
1200 2000			UVM-05P32C12	220.5	26.4×32.2×20.6	24	
	UVM-05P32C20		275.6	26.4×32.2×20.6	26		
15	25	1200 2000		UVM-15P25A12	187.4	27.2×24.8×23.9	22
				UVM-15P25A20	242.5	27.2×24.8×23.9	25
		1200 2000		UVM-15P25C12	220.5	26.4×32.2×20.6	23
	UVM-15P25C20			275.6	26.4×32.2×20.6	26	
	31.5	1200 2000		UVM-15P32A12	187.4	27.2×24.8×23.9	24
				UVM-15P32A20	242.5	27.2×24.8×23.9	25
1200 2000			UVM-15P32C12	220.5	26.4×32.2×20.6	24	
	UVM-15P32C20		275.6	26.4×32.2×20.6	26		
27	25		UVM-27P25C12	264.6	33.3×32.7×22	26	
			UVM-27P25C20	297.6	33.3×32.7×22	27	

Full description for circuit breaker

UVM type, Fixed type

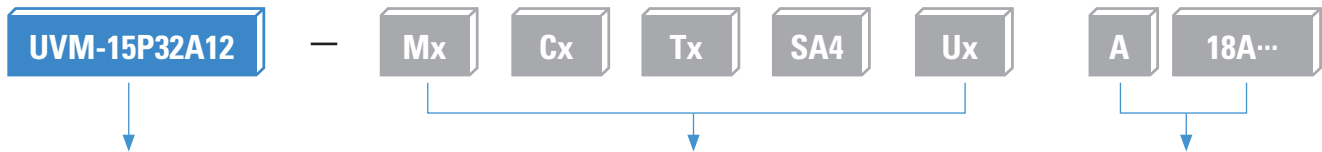

❶ Type of circuit breaker
(select from the previous page)

❷ Control source, auxiliary contacts and connector

❸ Accessories

※ In case of selecting ❸ Accessories, only type Symbol 'A' once. (ex. A18A)

Order form for circuit breaker

Please select only one item per line. (* Required selection)

UVM, VCB, Fixed type

(no extra charge extra charge)

❶ Type of VCB from selection table*	Quantity	ea
❷ Accessories		
Motor* (Mx)		page 164
<input type="radio"/> M2 DC 200V ~ 250V	<input type="radio"/> M3 DC 125V	<input type="radio"/> M4 DC 24V ~ 30V
<input type="radio"/> M5 DC 48V ~ 60V	<input type="radio"/> M6 AC 48V	<input type="radio"/> M7 AC 100V ~ 130V
<input type="radio"/> M8 AC 200V ~ 250V		
Closing coil* (Cx)		page 165
<input type="radio"/> C2 DC 200V ~ 250V	<input type="radio"/> C3 DC 125V	<input type="radio"/> C4 DC 24V ~ 30V
<input type="radio"/> C5 DC 48V ~ 60V	<input type="radio"/> C6 AC 48V	<input type="radio"/> C7 AC 100V ~ 130V
<input type="radio"/> C8 AC 200V ~ 250V		
Shunt trip coil* (Tx)		page 166
<input type="radio"/> T2 DC 200V ~ 250V	<input type="radio"/> T3 DC 125V	<input type="radio"/> T4 DC 24V ~ 30V
<input type="radio"/> T5 DC 48V ~ 60V	<input type="radio"/> T6 AC 48V	<input type="radio"/> T7 AC 100V ~ 130V
<input type="radio"/> T8 AC 200V ~ 250V		
Auxiliary contacts & Connector type*		page 169
<input type="checkbox"/> SA2 (4a4b, A-type)	<input type="checkbox"/> SA4 (10a10b, A-type)	<input type="checkbox"/> SQ2 (4a4b, Q-type)
		<input type="checkbox"/> SQ4 (10a10b, Q-type)
Under voltage release (Ux)		page 170
<input type="radio"/> U0* Without UVT	<input type="checkbox"/> U2 DC 200V ~ 250V	<input type="checkbox"/> U3 DC 125V
<input type="checkbox"/> U4 DC 24V ~ 30V	<input type="checkbox"/> U5 DC 48V ~ 60V	<input type="checkbox"/> U6 AC 48V
<input type="checkbox"/> U7 AC 100V ~ 130V	<input type="checkbox"/> U8 AC 200V ~ 250V	
※ Even without UVT, U0 must be selected to make VCB ordering code and description		
<small>Note) 1. In case of DC24V control source(M4, C4, T4, U4), it is recommended to be used through Rated Control Voltage. 2. SB2 and SB4 have been updated to SQ2 and SQ4. If you need the SB type, please contact your sales person or customer representative.</small>		
Secondary shunt trip coil		page 167
<input type="checkbox"/> A1 (Secondary shunt trip coil)	<input type="checkbox"/> A2 (Secondary shunt trip coil monitoring contact)	
※ In case of selecting A1, maximum auxiliary contacts are 9a9b		※ In case of selecting A2, maximum auxiliary contacts are 9a8b
Keylock		page 172
<input type="checkbox"/> A7 (Keylock)	<input type="checkbox"/> AM (KirkKey, CAMLOCK type)	<input type="checkbox"/> AN (KirkKey, CN-22 type)
<input type="checkbox"/> AP (KirkKey, Double CAMLOCK type)		
Button Padlock		page 173
<input type="radio"/> A8 (Button padlock)	<input type="radio"/> AX (Button padlock in open)	
Lead wire*		page 174
<input type="radio"/> AA (Lead wire)	<input type="radio"/> AB (User plug)	

Combination table

U0	1	
U1-8		1
A1 & A2	1	

Auxiliary contact

Symbol	10a10b
Standard	10 NO, 10 NC
with A1	9 NO, 9 NC
with A2	9 NO, 8 NC

Accessories (Sold separately)

CTU (Coil test unit)	<input type="checkbox"/> 73873171221 CTU (Coil test unit)	page 179
CTD (Condenser trip device)	<input type="checkbox"/> 76113143001 CTD (Condenser trip device) DC 125V <input type="checkbox"/> 76113143002 CTD (Condenser trip device) DC 250V	page 180
UDC (UVT delay controller)	<input type="checkbox"/> 52773171282 UDC (UVT delay controller) AC/DC 100~130V <input type="checkbox"/> 52773171283 UDC (UVT delay controller) AC/DC 200~250V <input type="checkbox"/> 52773171281 UDC (UVT delay controller) DC 48~60V and AC 48V	page 181

Dimensions

4.76kV, 25kA, 1200A

UVM type, Fixed type

[Unit: in(mm)]

Circuit breaker model

UVM-05P25A12

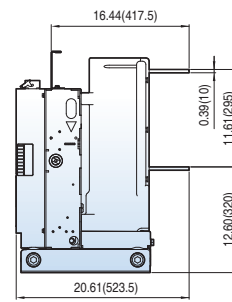
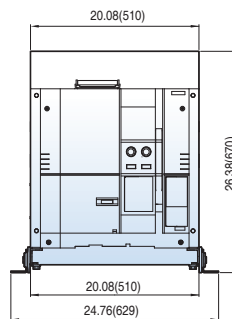
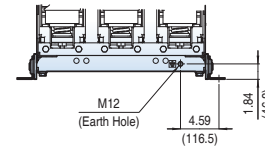
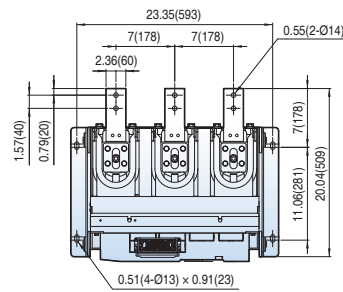

15kV, 25kA, 1200A

Circuit breaker model

UVM-15P25A12

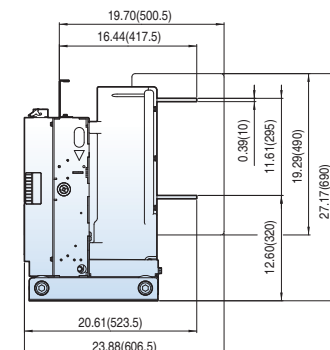
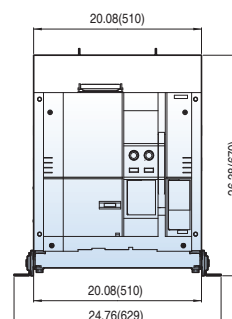
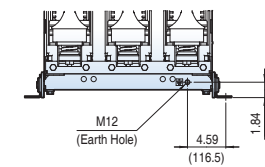
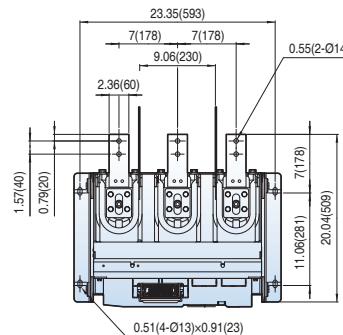

4.76/15kV, 25kA, 1200A

UVM type, Fixed type

Circuit breaker model

- UVM-05P25C12
- UVM-15P25C12

[Unit: in(mm)]

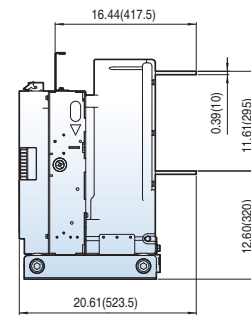
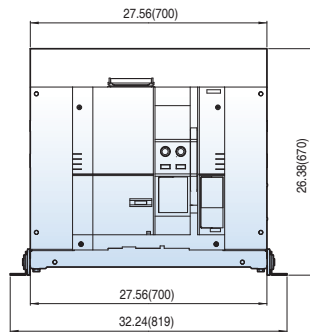
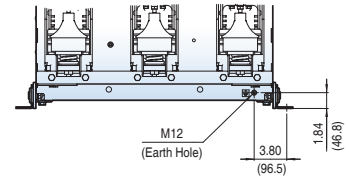
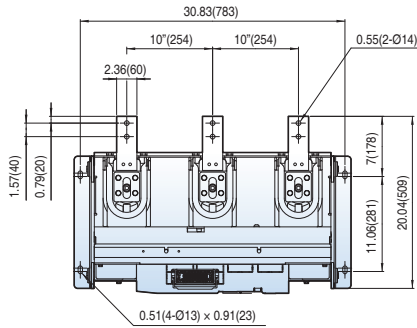

4.76, 31.5kA, 1200A

Circuit breaker model

- UVM-05P32A12

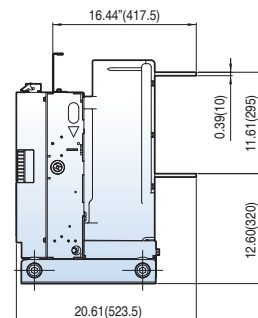
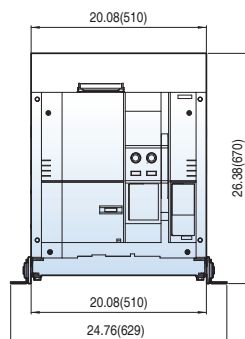
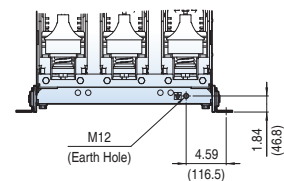
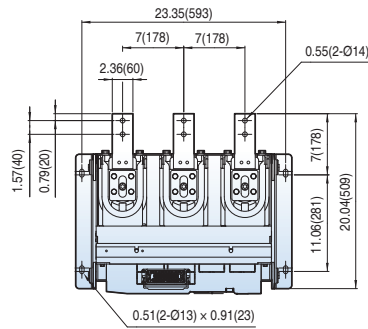

Dimensions

15kV, 31.5kA, 1200A

UVM type, Fixed type

[Unit: in(mm)]

Circuit breaker model

UVM-15P32A12

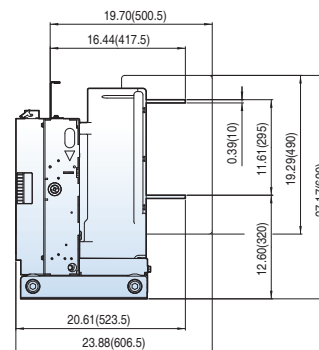
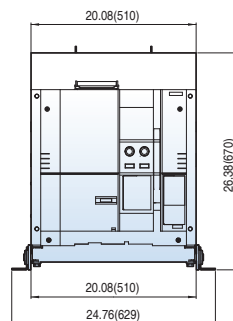
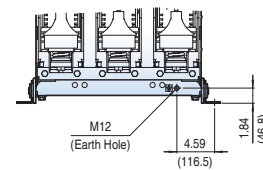
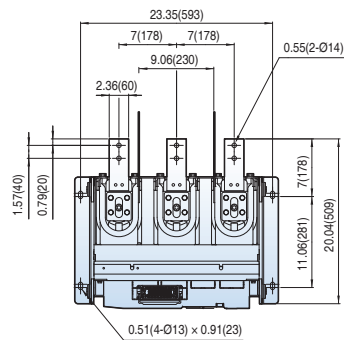

4.76/15kV, 31.5kA, 1200A

Circuit breaker model

UVM-05P32C12

UVM-15P32C12

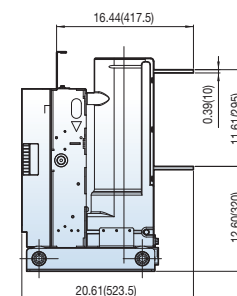
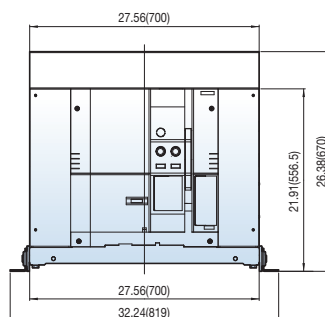
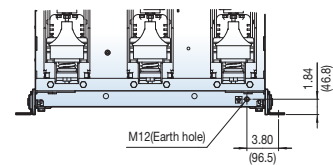
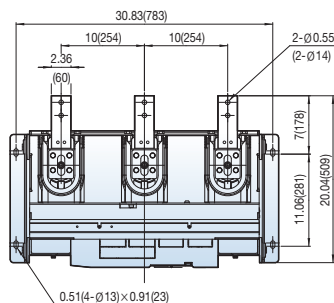

4.76kV, 25/31.5kA, 2000A

UVM type, Fixed type

Circuit breaker model

UVM-05P25A20
UVM-05P32A20

[Unit: in(mm)]

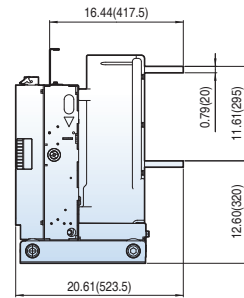
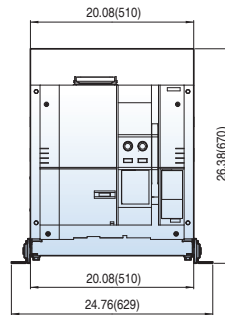
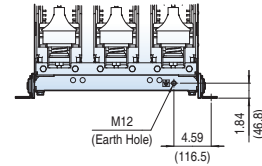
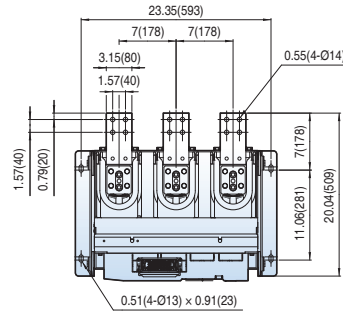

15kV, 25/31.5kA, 2000A

Circuit breaker model

UVM-15P25A20
UVM-15P32A20

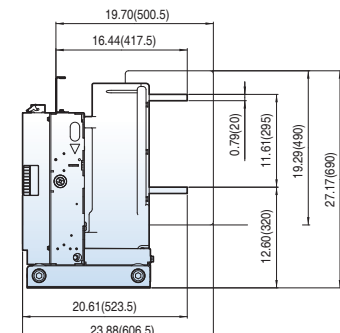
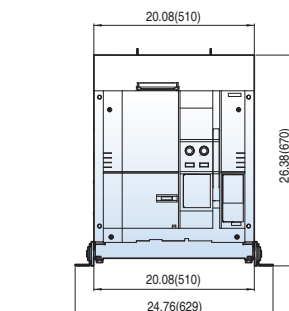
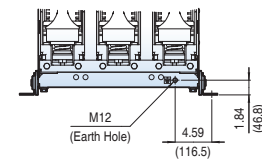
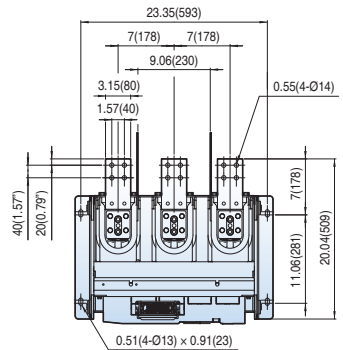

Dimensions

4.76/15kV, 25/31.5kA, 2000A

UVM type, Fixed type

Circuit breaker model

- UVM-05P25C20
- UVM-05P32C20
- UVM-15P25C20
- UVM-15P32C20

[Unit: in(mm)]

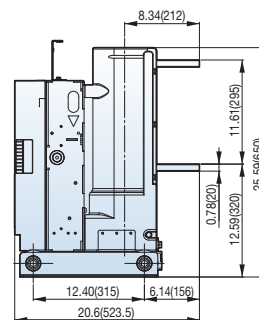
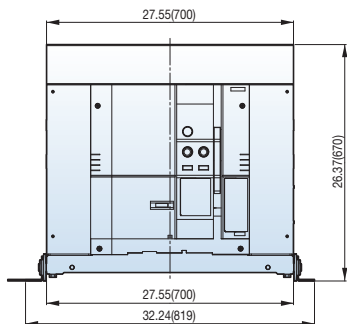
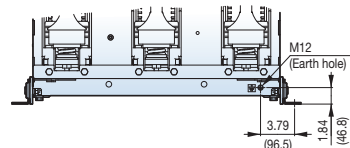
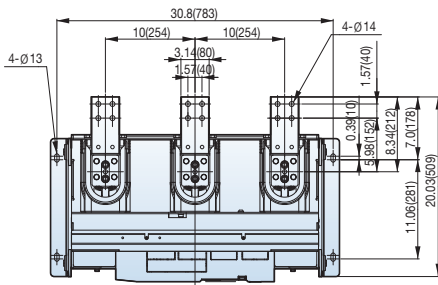

27kV, 25kA, 1200A

Circuit breaker model

- UVM-27P25C12

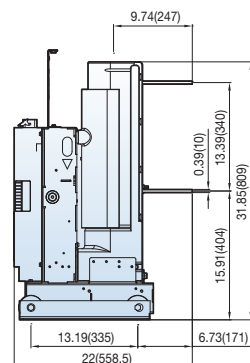
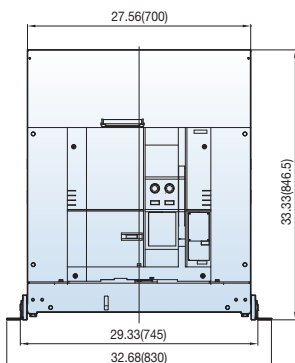
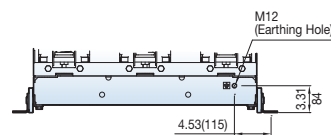
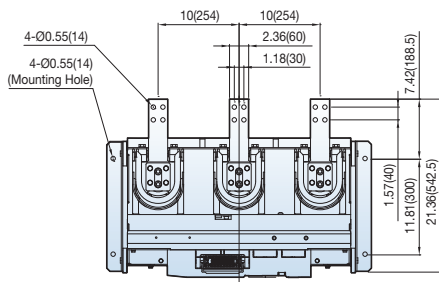

27kV, 25kA, 2000A

UVM type, Fixed type

Circuit breaker model
UVM-27P25C20

[Unit: in(mm)]

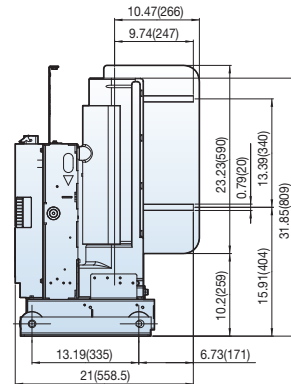
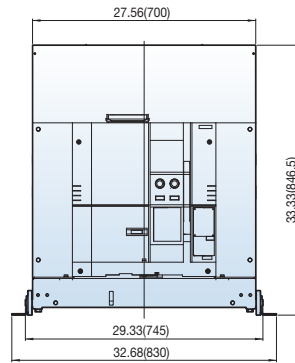
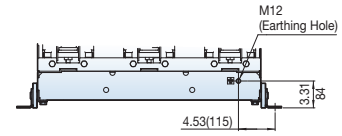
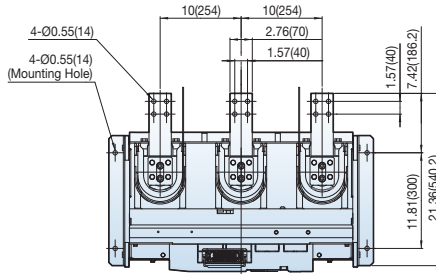

Memo

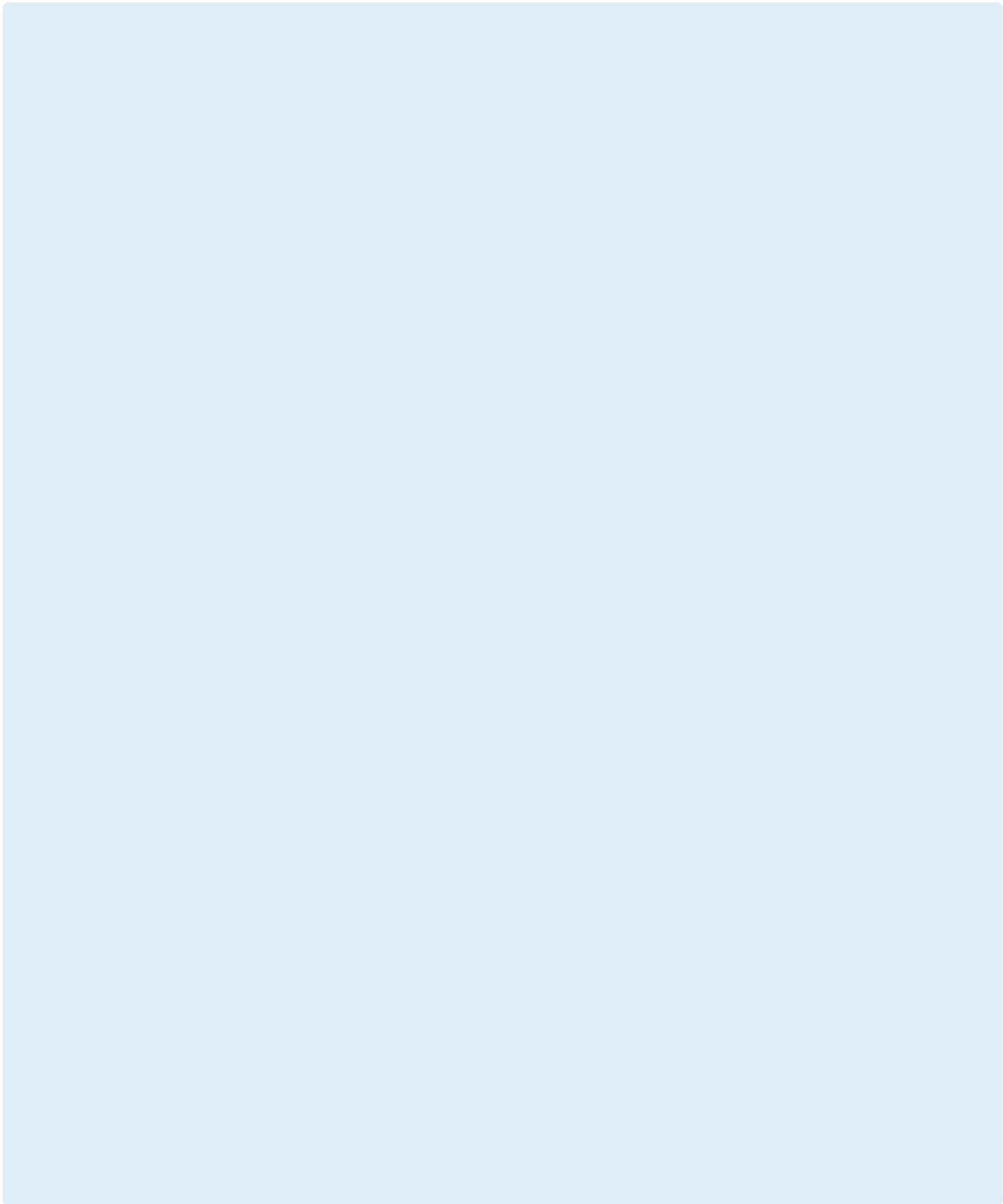

Susol UVH

Fixed type



Contents

▪ Ratings and description	30
▪ Selection guide	32
▪ Order form	34
▪ Dimensions	35

Ratings and description

UVH type, Fixed type

UVH-05P  US

Circuit breaker type			UVH-05P											
Rated voltage	Ur (kV)	4.76												
Rated withstand voltage	Power frequency (1min)	Ud (kV)	19											
	Lightening impulse (1.2×50µs)	Up (kV)	60											
Rated short-circuit current	Isc (kA)	25	31.5			40			50					
Rated normal current	Ir (A)	3000	4000	3000	4000	1200	2000	3000	4000	1200	2000	3000	4000	
Rated frequency	fr (Hz)	60	60	60	60	60	60	60	60	60	60	60	60	
Rated short-circuit making current	Ip (kA) at 50 Hz	-	-	-	-	-	-	-	-	-	-	-	-	
	Ip (kA) at 60 Hz	65	65	81.9	81.9	104	104	104	104	130	130	130	130	
Rated short-time withstand current	Ik (kA)	25	25	31.5	31.5	40	40	40	40	50	50	50	50	
	3sec	●	●	●	●	●	●	●	●	●	●	●	●	
Operating sequence	O - 0.3s - CO - 15s - CO	●	●	●	●	●	●	●	●	●	●	●	●	

UVH-15P  US

Circuit breaker type			UVH-15P											
Rated voltage	Ur (kV)	15												
Rated withstand voltage	Power frequency (1min)	Ud (kV)	36											
	Lightening impulse (1.2×50µs)	Up (kV)	95											
Rated short-circuit current	Isc (kA)	25	31.5			40			50					
Rated normal current	Ir (A)	3000	4000	3000	4000	1200	2000	3000	4000	1200	2000	3000	4000	
Rated frequency	fr (Hz)	60	60	60	60	60	60	60	60	60	60	60	60	
Rated short-circuit making current	Ip (kA) at 50 Hz	-	-	-	-	-	-	-	-	-	-	-	-	
	Ip (kA) at 60 Hz	65	65	81.9	81.9	104	104	104	104	130	130	130	130	
Rated short-time withstand current	Ik (kA)	25	25	31.5	31.5	40	40	40	40	50	50	50	50	
	3sec	●	●	●	●	●	●	●	●	●	●	●	●	
Operating sequence	O - 0.3s - CO - 15s - CO	●	●	●	●	●	●	●	●	●	●	●	●	

Technical data

Opening time		Less than 0.04 sec
Rated breaking time		3 Cycle
No-load closing time		Less than 0.06 sec
Test class	Mechanical endurance	M2 (10,000)
	Electrical endurance	Reference standard (page 210)
	Capacitance	C2
Operating temperature	Low	-40 °C
	High	40 °C

UVH-27P C US

Circuit breaker type		UVH-27P									
Rated voltage	Ur (kV)	27									
Rated withstand voltage	Power frequency (1min)	Ud (kV)	60								
	Lightening impulse (1.2×50μs)	Up (kV)	125								
Rated short-circuit current	Isc (kA)	25	31.5				40				
Rated normal current	Ir (A)	2500	2750	1200	2000	2500	2750	1200	2000	2500	2750
Rated frequency	fr (Hz)	60	60	60	60	60	60	60	60	60	60
Rated short-circuit making current	I _p (kA) at 50 Hz	-	-	-	-	-	-	-	-	-	-
	I _p (kA) at 60 Hz	65	65	81.9	81.9	81.9	81.9	104	104	104	104
Rated short-time withstand current	I _k (kA)	25	25	31.5	31.5	31.5	31.5	40	40	40	40
	3sec	●	●	●	●	●	●	●	●	●	●
Operating sequence	O - 0.3s - CO - 15s - CO	●	●	●	●	●	●	●	●	●	●

UVH-38P C US

Circuit breaker type		UVH-38P						
Rated voltage	Ur (kV)	38						
Rated withstand voltage	Power frequency (1min)	Ud (kV)	80					
	Lightening impulse (1.2×50μs)	Up (kV)	170					
Rated short-circuit current	Isc (kA)	31.5	40					
Rated normal current	Ir (A)	1200	2000	3000	1200	2000	3000	
Rated frequency	fr (Hz)	60	60	60	60	60	60	
Rated short-circuit making current	I _p (kA) at 60 Hz	81.9	81.9	81.9	104	104	104	
Rated short-time withstand current	I _k (kA)	31.5	31.5	31.5	40	40	40	
	3sec	●	●	●	●	●	●	
Operating sequence	O - 0.3s - CO - 15s - CO	●	●	●	●	●	●	

Technical data

Opening time		Less than 0.04 sec
Rated breaking time		3 Cycle
No-load closing time		Less than 0.06 sec
Test class	Mechanical endurance	M2 (10,000)
	Electrical endurance	Reference standard (page 210)
	Capacitance	C2
Operating temperature	Low	-40 °C
	High	40 °C

Selection guide

Description for circuit breaker type

UVH type, Fixed type

UVH	15	P	40	A	12
Model	Rated voltage (kV)	Type	Interrupting current (kA)	Phase distance	Rated current (A)
UVH Susol VCB	05 4.76 15 15	P Fixed Type	40 40 50 50 25 25 32 31.5 40 40 50 50	A 7in(178mm) C 10in(254mm) C 10in(254mm) L 12.59in(320mm)	12 1200 20 2000 30 3000 40 4000

Selection table of circuit breaker type

Ur [kV]	Isc [kA]	Ir [A]			Circuit breaker Model	Weight [lb]	Outline dimension H×W×D [in]	Dimension page
		p = 7"	p = 10"	p = 12.59"				
4.76	25		3000	4000	UVH-05P25C30	540.1	29.7×32.2×24.8	36
					UVH-05P25L40	970.0	37.4×43.8×25.6	37
	31.5		3000	4000	UVH-05P32C30	540.1	29.7×32.2×24.8	36
					UVH-05P32L40	970.0	37.4×43.8×25.6	37
	40	1200 2000			UVH-05P40A12	407.9	29.7×24.6×24.4	35
					UVH-05P40A20	407.9	29.7×24.6×24.4	35
		1200 2000 3000			UVH-05P40C12	429.9	29.7×32.2×24.4	36
					UVH-05P40C20	429.9	29.7×32.2×24.4	36
					UVH-05P40C30	540.1	29.7×32.2×24.8	36
					UVH-05P40L40	970.0	37.4×43.8×25.6	37
	50	1200 2000			UVH-05P50A12	407.9	29.7×24.6×24.4	35
					UVH-05P50A20	407.9	29.7×24.6×24.4	35
1200 2000 3000				UVH-05P50C12	429.9	29.7×32.2×24.4	36	
				UVH-05P50C20	429.9	29.7×32.2×24.4	36	
				UVH-05P50C30	540.1	29.7×32.2×24.8	36	
				UVH-05P50L40	970.0	37.4×43.8×25.6	37	
15	25		3000	4000	UVH-15P25C30	540.1	29.7×32.2×27.5	37
					UVH-15P25L40	970.0	37.4×43.8×25.6	37
	31.5		3000	4000	UVH-15P32C30	540.1	29.7×32.2×27.5	37
					UVH-15P32L40	970.0	37.4×43.8×25.6	37
	40	1200 2000			UVH-15P40A12	407.9	34×24.6×27.5	35
					UVH-15P40A20	407.9	34×24.6×27.5	35
		1200 2000 3000			UVH-15P40C12	429.9	29.7×32.2×24.4	36
					UVH-15P40C20	429.9	29.7×32.2×24.4	36
					UVH-15P40C30	540.1	29.7×32.2×27.5	37
					UVH-15P40L40	970.0	37.4×43.8×25.6	37
	50	1200 2000			UVH-15P50A12	407.9	34×24.6×27.5	35
					UVH-15P50A20	407.9	34×24.6×27.5	35
1200 2000 3000				UVH-15P50C12	429.9	29.7×32.2×24.4	36	
				UVH-15P50C20	429.9	29.7×32.2×24.4	36	
				UVH-15P50C30	540.1	29.7×32.2×27.5	37	
				UVH-15P50L40	970.0	37.4×43.8×25.6	37	

Description for circuit breaker type

UVH type, Fixed type

Model		Rated voltage (kV)		Type		Interrupting current (kA)		Phase distance		Rated current (A)	
UVH	Susol VCB	27	27	P	Fixed Type	32	31.5	C	10in(254mm)	12	1200
						40	40			20	2000
						25	25	C	10in(254mm)	25	2500
						32	31.5			28	2750
						40	40				
		38	38	P	Fixed Type	32	31.5	E	11.8in(300mm)	12	1200
						40	40			20	2000
										30	3000

Selection table of circuit breaker type

Ur [kV]	Isc [kA]	Ir[A]		Circuit breaker Model	Weight [lb]	Outline dimension H×W×D [in]	Dimension page
		p = 10"	p = 11.8"				
27	25	2500		UVH-27P25C25	661.4	36.7×32.2×31.3	39
		2750		UVH-27P25C28	661.4	36.7×32.2×31.3	39
	31.5	1200		UVH-27P32C12	573.2	36.7×32.2×31.3	38
		2000		UVH-27P32C20	573.2	36.7×32.2×31.3	38
		2500		UVH-27P32C25	661.4	36.7×32.2×31.3	39
		2750		UVH-27P32C28	661.4	36.7×32.2×31.3	39
	40	1200		UVH-27P40C12	573.2	36.7×32.2×31.3	38
		2000		UVH-27P40C20	573.2	36.7×32.2×31.3	38
2500			UVH-27P40C25	661.4	36.7×32.2×31.3	39	
2750			UVH-27P40C28	661.4	36.7×32.2×31.3	39	
38	31.5		1200	UVH-38P32E12	881.8	41×37.2×37.5	40
			2000	UVH-38P32E20	881.8	41×37.2×37.5	40
			3000	UVH-38P32E30	1038.8	41×37.2×37.5	40
	40		1200	UVH-38P40E12	881.8	41×37.2×37.5	40
			2000	UVH-38P40E20	881.8	41×37.2×37.5	40
			3000	UVH-38P40E30	1038.8	41×37.2×37.5	40

Order form

Full description for circuit breaker

UVH type, Fixed type

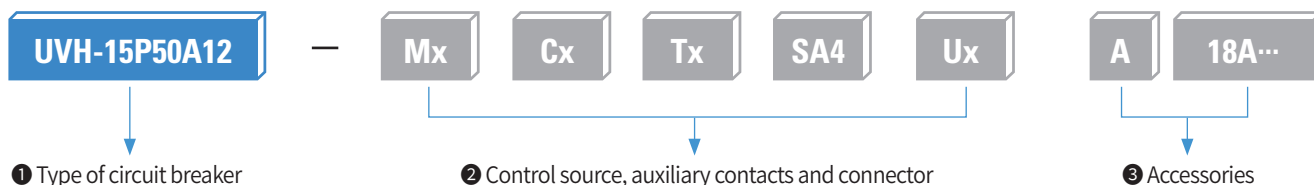

① Type of circuit breaker
(select from the previous page)

② Control source, auxiliary contacts and connector

③ Accessories

※ In case of selecting ③ Accessories, only type Symbol 'A' once. (ex. A18A)

Order form for circuit breaker

Please select only one item per line. (* Required selection)

UVH, VCB, Fixed type

(No extra charge extra charge)

① Type of VCB from selection table*		Quantity	ea
② Accessories			
Motor* (Mx)			page 164
<input type="radio"/> M2	<input type="radio"/> M3	<input type="radio"/> M4	<input type="radio"/> M5
DC 200V ~ 250V	DC 125V	DC 24V ~ 30V	DC 48V ~ 60V
<input type="radio"/> M6	<input type="radio"/> M7	<input type="radio"/> M8	
AC 48V	AC 100V ~ 130V	AC 200V ~ 250V	
Closing coil* (Cx)			page 165
<input type="radio"/> C2	<input type="radio"/> C3	<input type="radio"/> C4	<input type="radio"/> C5
DC 200V ~ 250V	DC 125V	DC 24V ~ 30V	DC 48V ~ 60V
<input type="radio"/> C6	<input type="radio"/> C7	<input type="radio"/> C8	
AC 48V	AC 100V ~ 130V	AC 200V ~ 250V	
Shunt trip coil* (Tx)			page 166
<input type="radio"/> T2	<input type="radio"/> T3	<input type="radio"/> T4	<input type="radio"/> T5
DC 200V ~ 250V	DC 125V	DC 24V ~ 30V	DC 48V ~ 60V
<input type="radio"/> T6	<input type="radio"/> T7	<input type="radio"/> T8	
AC 48V	AC 100V ~ 130V	AC 200V ~ 250V	
Auxiliary contacts & Connector type*			page 169
<input type="radio"/> SA2(4a4b,A-type,UVH-05/15/27P Only)		<input type="radio"/> SA4(10a10b,A-type,UVH-05/15/27P Only)	
<input type="radio"/> SQ2(4a4b,Q-type,UVH-05/15/27/38P)		<input type="radio"/> SQ4(10a10b,A-type,UVH-05/15/27/38P)	
Under voltage release (Ux)			page 170
<input type="radio"/> U0	<input type="checkbox"/> U2	<input type="checkbox"/> U3	<input type="checkbox"/> U4
Without UVT	DC 200V ~ 250V	DC 125V	DC 24V ~ 30V
<input type="checkbox"/> U5	<input type="checkbox"/> U6	<input type="checkbox"/> U7	<input type="checkbox"/> U8
DC 48V ~ 60V	AC 48V	AC 100V ~ 130V	AC 200V ~ 250V
※ Even without UVT, U0 must be selected to make VCB ordering code and description			
Secondary shunt trip coil			page 167
<input type="checkbox"/> A1 (Secondary shunt trip coil)		<input type="checkbox"/> A2 (Secondary shunt trip coil monitoring contact)	
※ In case of selecting A2, maximum auxiliary contacts are 10a9b			
Latch checking s/w			page 171
<input type="checkbox"/> A6			
※ In case of selecting UVT, latch checking s/w is applied by default, so cannot select it additionally.			
Keylock			page 172
<input type="checkbox"/> A7 (Keylock(Individual key))		<input type="checkbox"/> AM (Kirk key, CAMLOCK type)	
Button padlock			page 173
<input type="radio"/> A8 (Button padlock)			
Lead wire*			page 174
<input type="radio"/> AA (Lead wire)		<input type="radio"/> AB (User Plug)	

Note) 1. In case of DC24V control source(M4, C4, T4, U4), it is recommended to be used through Rated Control Voltage.

2. SB2 and SB4 have been updated to SQ2 and SQ4. If you need the SB type, please contact your sales person or customer representative.

Combination table

U0	1	
U1-8		1
A1 & A2	1	

Auxiliary contact

Symbol	10a10b
Standard	10 NO, 10 NC
with A1	10 NO, 10 NC
with A2	10 NO, 9 NC

Accessories (Sold separately)

Charge handle	<input type="checkbox"/> 55213143046	page 189
CTU (Coil test unit)	<input type="checkbox"/> 73873171221 CTU (Coil test unit)	page 179
CTD (Condenser trip device)	<input type="checkbox"/> 76113143001 CTD (Condenser trip device) DC 125V <input type="checkbox"/> 76113143002 CTD (Condenser trip device) DC 250V	page 180
UDC (UVT delay controller)	<input type="checkbox"/> 52773171282 UDC (UVT delay controller) AC/DC 100~130V <input type="checkbox"/> 52773171283 UDC (UVT delay controller) AC/DC 200~250V <input type="checkbox"/> 52773171281 UDC (UVT delay controller) DC 48~60V and AC 48V	page 181

4.76kV, 40/50kA, 1200/2000A

UVH type, Fixed type

Circuit breaker model

- UVH-05P40A12
- UVH-05P40A20
- UVH-05P50A12
- UVH-05P50A20

[Unit: in(mm)]

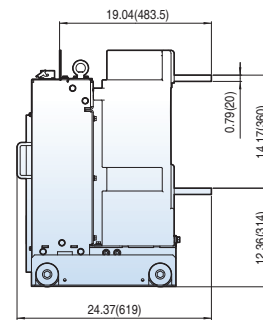
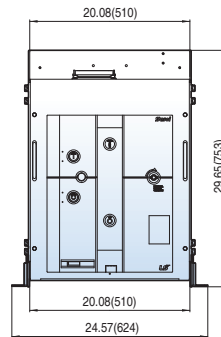
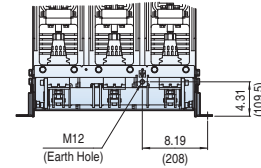
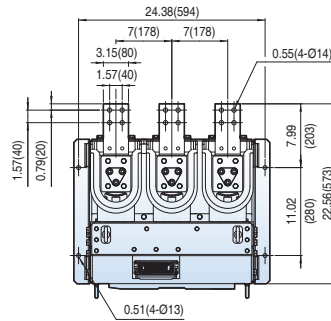

15kV, 40/50kA, 1200/2000A

Circuit breaker model

- UVH-15P40A12
- UVH-15P40A20
- UVH-15P50A12
- UVH-15P50A20

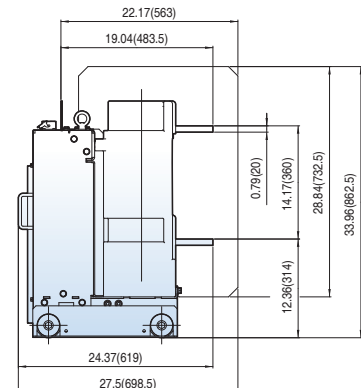
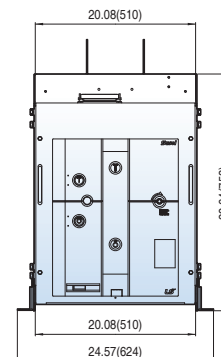
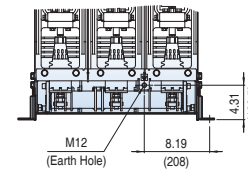
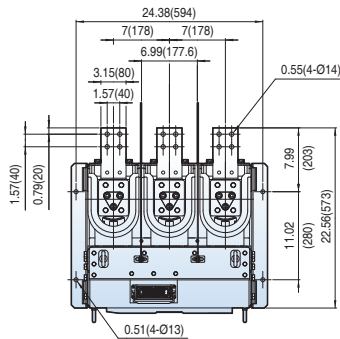

Dimensions

4.76/15kV, 40/50kA, 1200/2000A

UVH type, Fixed type

[Unit: in(mm)]

Circuit breaker model

- UVH-05P40C12
- UVH-05P40C20
- UVH-05P50C12
- UVH-05P50C20
- UVH-15P40C12
- UVH-15P40C20
- UVH-15P50C12
- UVH-15P50C20

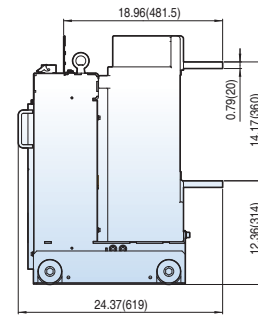
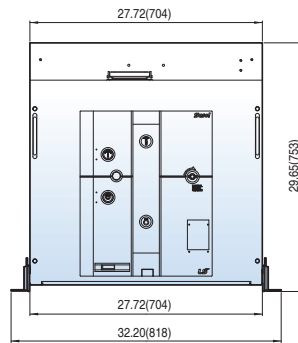
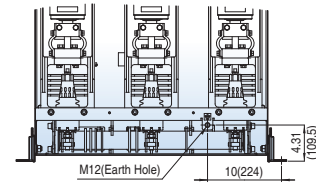
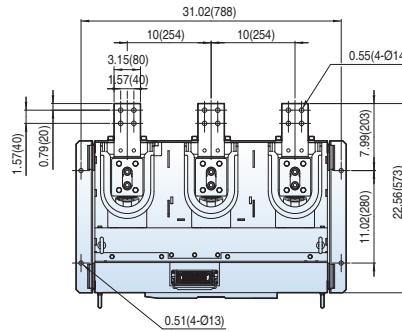

4.76kV, 25/31.5/40/50kA, 3000A

Circuit breaker model

- UVH-05P25C30
- UVH-05P32C30
- UVH-05P40C30
- UVH-05P50C30

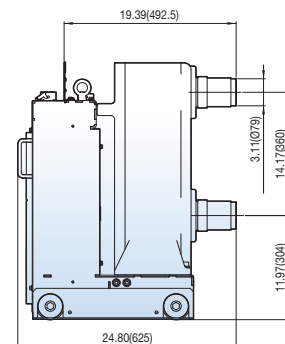
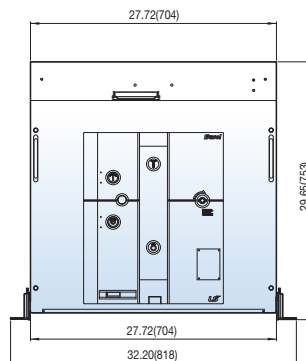
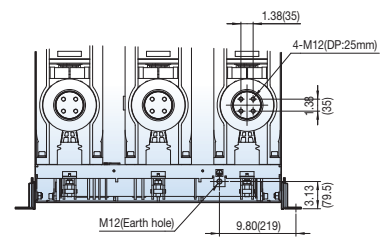
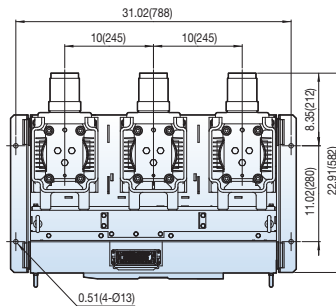

15kV, 25/31.5/40/50kA, 3000A

UVH type, Fixed type

Circuit breaker model

- UVH-15P25C30
- UVH-15P32C30
- UVH-15P40C30
- UVH-15P50C30

[Unit: in(mm)]

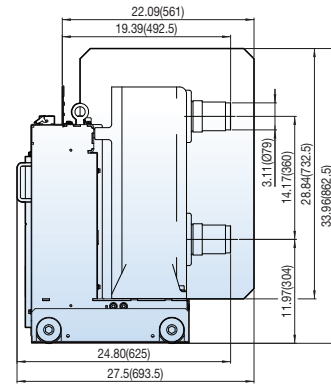
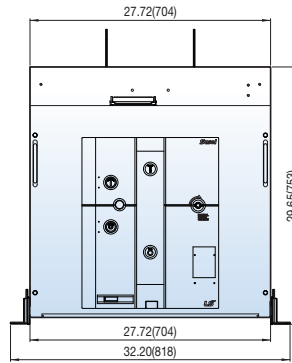
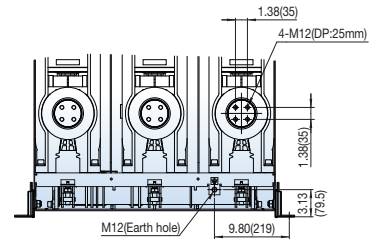
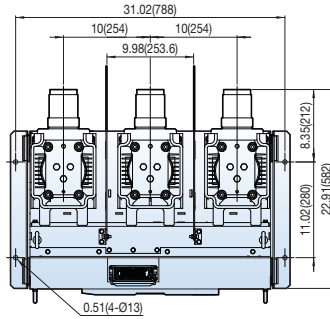

4.76/15kV, 25/31.5/40/50kA, 4000A

Circuit breaker model

- UVH-05P25L40
- UVH-05P32L40
- UVH-05P40L40
- UVH-05P50L40
- UVH-15P25L40
- UVH-15P32L40
- UVH-15P40L40
- UVH-15P50L40

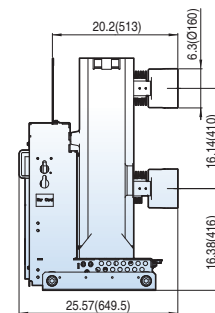
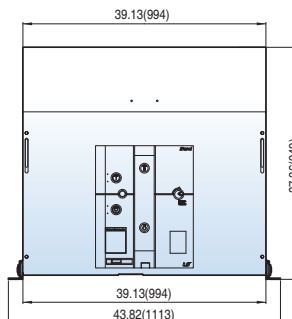
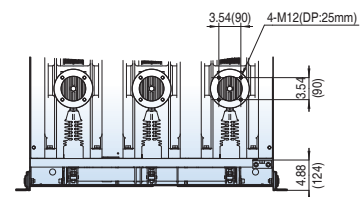
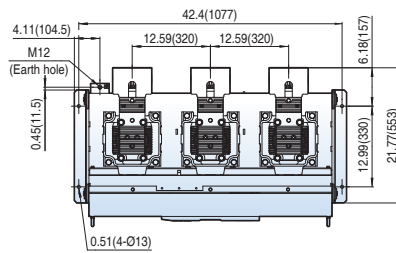

Dimensions

27kV, 31.5/40kA, 1200A

UVH type, Fixed type

[Unit: in(mm)]

Circuit breaker model

UVH-27P32C12
UVH-27P40C12

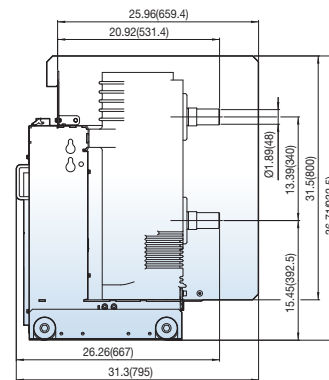
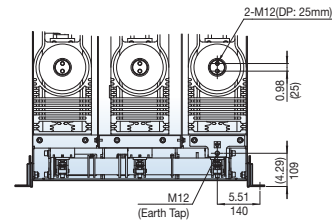
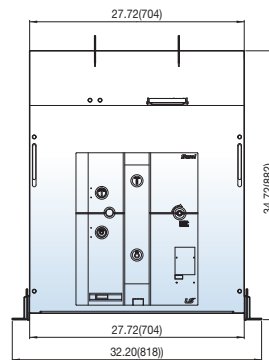
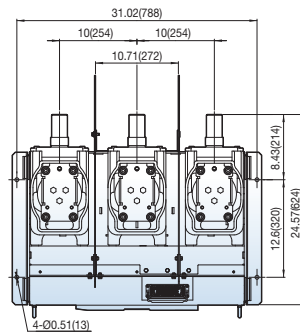

27kV, 31.5/40kA, 2000A

Circuit breaker model

UVH-27P32C20
UVH-27P40C20

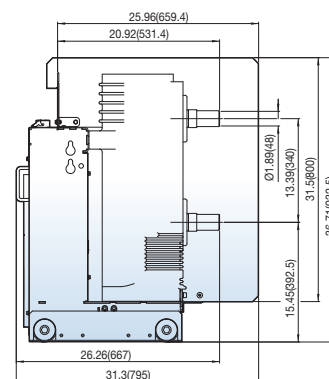
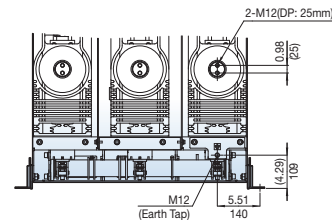
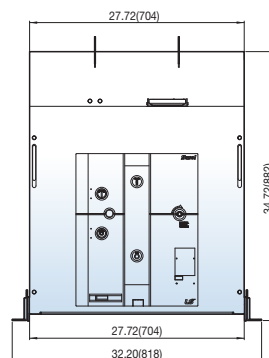
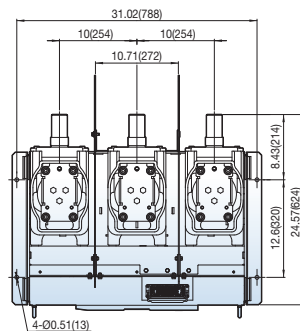

27kV, 25/31.5/40kA, 2500A

UVH type, Fixed type

Circuit breaker model

- UVH-27P25C25
- UVH-27P32C25
- UVH-27P40C25

[Unit: in(mm)]

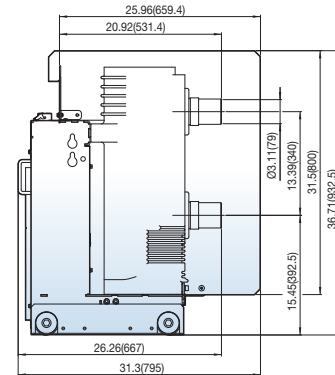
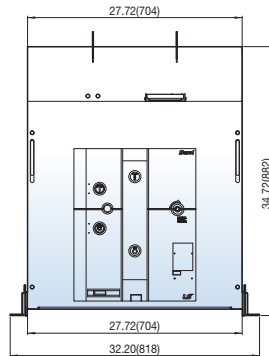
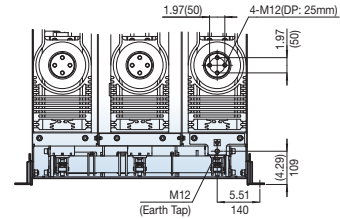
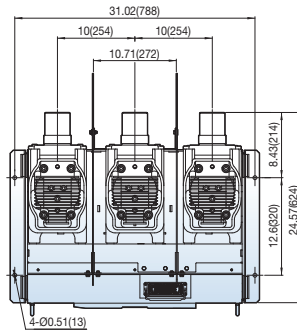

27kV, 25/31.5/40kA, 2750A

Circuit breaker model

- UVH-27P25C28
- UVH-27P32C28
- UVH-27P40C28

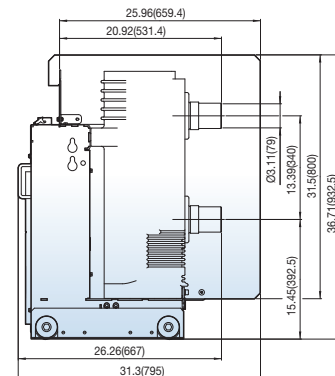
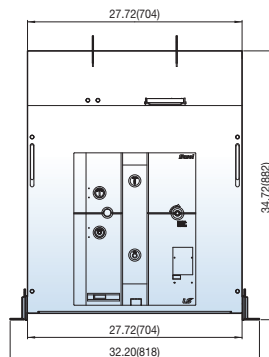
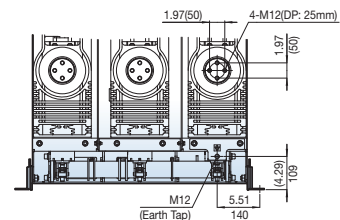
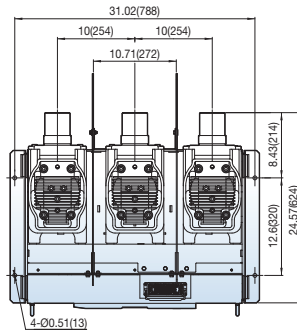

Dimensions

38kV, 31.5/40kA, 1200/2000A

UVH type, Fixed type

Circuit breaker model

- UVH-38P32E12
- UVH-38P32E20
- UVH-38P40E12
- UVH-38P40E20

[Unit: in(mm)]

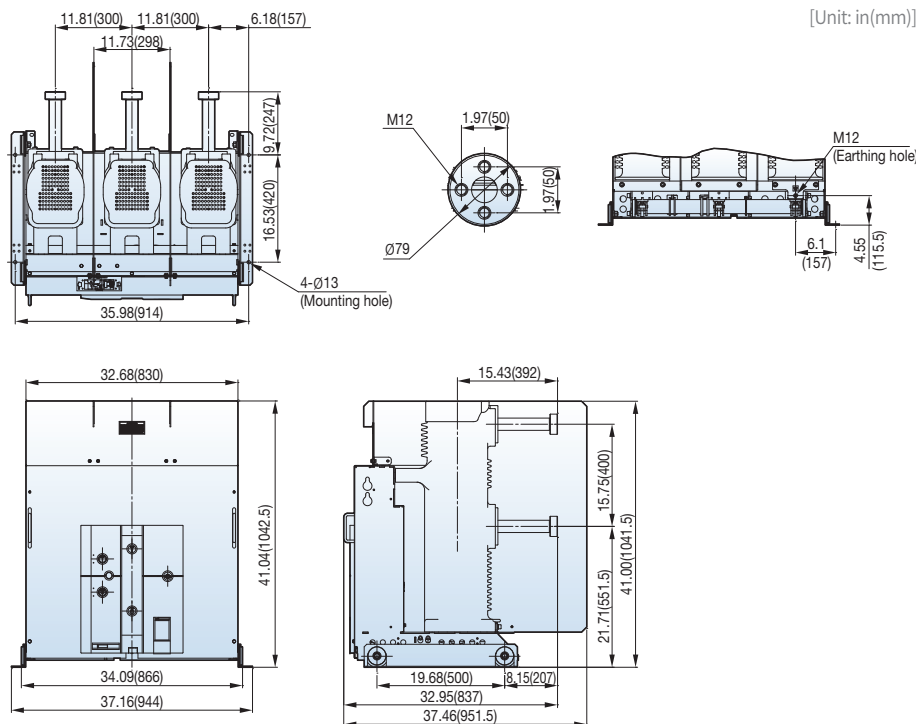

38kV, 31.5/40kA, 3000A

Circuit breaker model

- UVH-38P32E30
- UVH-38P40E30

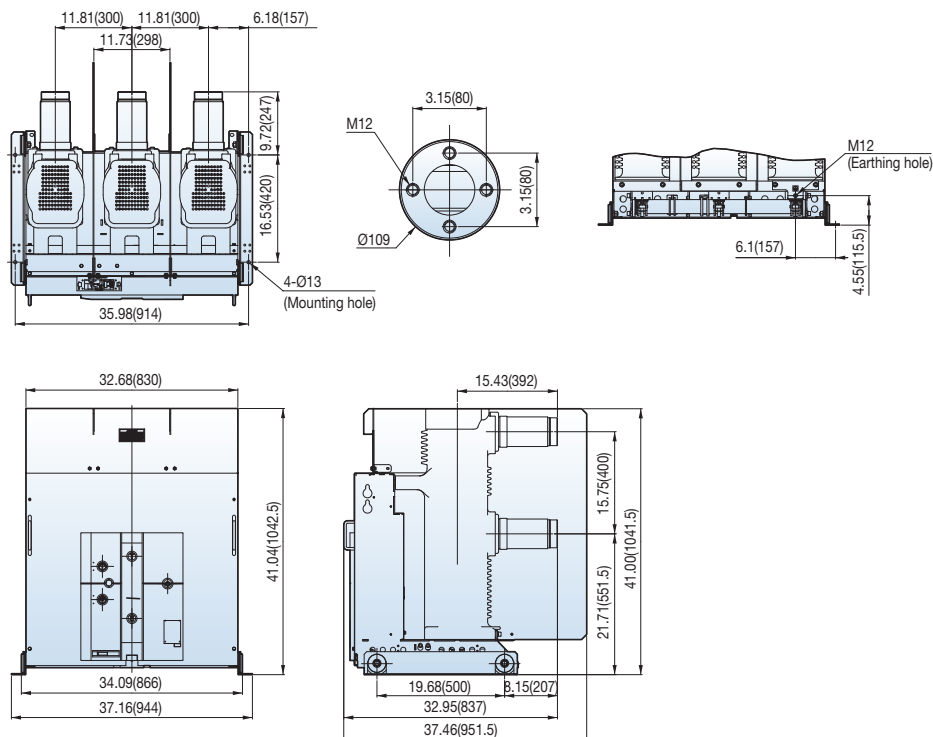

Susol UVL

Draw-out type
(Draw in/out by using screw)



Contents

▪ Ratings and description	42
▪ Selection guide	43
▪ Order form	47
▪ Dimensions	49

Ratings and description

UVL type, Draw-out type



Circuit breaker type		UVL-05H				UVL-15H			
Rated voltage	Ur (kV)	4.76				15			
Rated withstand voltage	Power frequency (1min)	19				36			
	Lightening impulse (1.2×50µs)	60				95			
Rated short-circuit current	Isc (kA)	25	31.5		25	31.5			
Rated normal current	Ir (A)	1200	2000	1200	2000	1200	2000	1200	2000
Rated frequency	fr (Hz)	60	60	60	60	60	60	60	60
Rated short-circuit making current	Ip (kA) at 60 Hz	65	65	81.9	81.9	65	65	81.9	81.9
Rated short-time withstand current	Ik (kA)	25	25	31.5	31.5	25	25	31.5	31.5
	3sec	●	●	●	●	●	●	●	●
Operating sequence	O - 0.3s - CO - 15s - CO	●	●	●	●	●	●	●	●

Technical data

Opening time		Less than 0.04 sec
Rated breaking time		3 Cycle
No-load closing time		Less than 0.06 sec
Test class	Mechanical endurance	M2 (10,000)
	Electrical endurance	Reference standard (page 210)
	Capacitance	C2
Operating temperature	Low	-40 °C
	High	40 °C

Description of circuit breaker for arc resistance type MCSG

UVL type, Draw-out type

Withdrawl, VCB Cradle for MCSG

UVL	15	H	32	B	20
Model	Rated voltage (kV)	Type	Interrupting current (kA)	Phase distance	Rated current (A)
UVL Susol VCB	05 4.76 15 15	H Draw-out Type (For UVL, Arc type MCSG)	25 25 32 31.5	R 5.9in(150mm) S 8.27in(210mm) B 8.27in(210mm)	12 1200 20 2000

Selection table of circuit breaker for Arc type MCSG

Ur [kV]	Isc [kA]	Symbol	Ir [A]		Circuit breaker Model	Weight [lb]	Outline dimension H×W×D [in]	Dimension page
			p = 5.9"	p = 8.27"				
4.76	25	R	1200		UVL-05H25R12	286.6	28.1×19.8×25.3	49
		S		1200	UVL-05H25S12	308.6	28.1×25.7×25.3	49
		B		2000	UVL-05H25B20	352.7	28.1×25.7×25.3	50
	31.5	R	1200		UVL-05H32R12	286.6	28.1×19.8×25.3	49
		S		1200	UVL-05H32S12	308.6	28.1×25.7×25.3	49
		B		2000	UVL-05H32B20	352.7	28.1×25.7×25.3	50
15	25	R	1200		UVL-15H25R12	286.6	28.1×19.8×25.3	49
		S		1200	UVL-15H25S12	308.6	28.1×25.7×25.3	49
		B		2000	UVL-15H25B20	352.7	28.1×25.7×25.3	50
	31.5	R	1200		UVL-15H32R12	286.6	28.1×19.8×25.3	49
		S		1200	UVL-15H32S12	308.6	28.1×25.7×25.3	49
		B		2000	UVL-15H32B20	352.7	28.1×25.7×25.3	50

Selection guide

Description of circuit breaker for Non-Arc type MCSG

UVL type, Draw-out type

Withdrawal, VCB Cradle for MCSG

UVL	15	H	32	S	20
Model	Rated voltage (kV)	Type	Interrupting current (kA)	Phase distance	Rated current (A)
UVL Susol VCB	05 4.76 15 15	H Draw-out Type (For UVL, Non-arc type MCSG)	25 25 32 31.5	B 8.27in(210mm) S 8.27in(210mm)	12 1200 20 2000

Selection table of circuit breaker for Non-Arc type MCSG

Ur [kV]	Isc [kA]	Symbol	Ir [A]		Circuit breaker Model	Weight [lb]	Outline dimension H×W×D [in]	Dimension page
			p = 5.9"	p = 8.27"				
4.76	25	B		1200	UVL-05H25B12	264.6	28.1×25.7×25.5	51
		S		2000	UVL-05H25S20	330.7	28.1×25.7×25.5	51
	31.5	B		1200	UVL-05H32B12	264.6	28.1×25.7×25.5	51
		S		2000	UVL-05H32S20	330.7	28.1×25.7×25.5	51
15	25	B		1200	UVL-15H25B12	264.6	28.1×25.7×25.5	51
		S		2000	UVL-15H25S20	330.7	28.1×25.7×25.5	51
	31.5	B		1200	UVL-15H32B12	264.6	28.1×25.7×25.5	51
		S		2000	UVL-15H32S20	330.7	28.1×25.7×25.5	51

Description of circuit breaker for L-type Cradle

UVL type, Draw-out type

Withdrawl, VCB Cradle for MCSG

UVL	15	H	32	A	12
Model	Rated voltage (kV)	Type	Interrupting current (kA)	Phase distance	Rated current (A)
UVL Susol VCB	05 4.76 15 15	H Draw-out Type (For UVL, L-type Cradle)	25 25 32 31.5	A 5.9in(150mm) S 8.27in(210mm)	12 1200 20 2000

Selection table of circuit breaker for L-type Cradle

Ur [kV]	Isc [kA]	Symbol	Ir [A]		Circuit breaker Model	Weight [lb]	Outline dimension H×W×D [in]	Dimension page
			p = 5.9"	p = 8.27"				
4.76	25	A	1200		UVL-05H25A12	253.5	28.1×19.8×25.3	52
		S		2000	UVL-05H25S20	330.7	28.1×25.7×25.5	52
	31.5	A	1200		UVL-05H32A12	253.5	28.1×19.8×25.3	52
		S		2000	UVL-05H32S20	330.7	28.1×25.7×25.5	52
15	25	A	1200		UVL-15H25A12	253.5	28.1×19.8×25.3	52
		S		2000	UVL-15H25S20	330.7	28.1×25.7×25.5	52
	31.5	A	1200		UVL-15H32A12	253.5	28.1×19.8×25.3	52
		S		2000	UVL-15H32S20	330.7	28.1×25.7×25.5	52

Selection guide

Description for Cradle

UVL type, Draw-out type

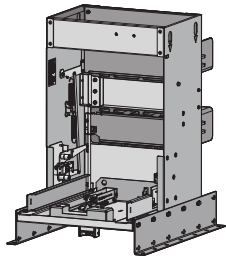

L-Type

UVCL	15	L	32	S	20
Model	Rated voltage (kV)	Type	Interrupting current (kA)	Phase distance	Rated current (A)
UVCL Susol UL VCB Cradle (UVCL)	05 4.76 15 15	L MCSG Cradle type	25 25 32 31.5	P 5.9in(150mm) S 8.27in(210mm)	12 1200 20 2000

Selection table of cradle

Selection table for H-Type VCB(For L-type Cradle)

Ur [kV]	Isc [kA]	Symbol	Ir [A]		Cradle model	Outline dimension H×W×D [in]	Dimension page
			p = 5.9"	p = 8.27"			
4.76	25	P	1200		UVCL-05L25P12	26.4×23.2×20	53
		S		2000	UVCL-05L25S20	26.4×23.2×20	53
	31.5	P	1200		UVCL-05L32P12	26.4×23.2×20	53
		S		2000	UVCL-05L32S20	26.4×23.2×20	53
15	25	P	1200		UVCL-15L25P12	26.4×23.2×20	53
		S		2000	UVCL-15L25S20	26.4×23.2×20	53
	31.5	P	1200		UVCL-15L32P12	26.4×23.2×20	53
		S		2000	UVCL-15L32S20	26.4×23.2×20	53

Full description for circuit breaker

UL type, Draw-out type

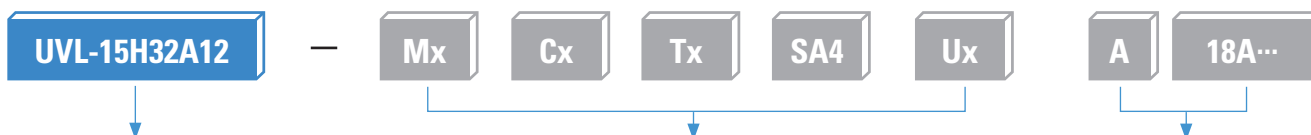

1 Type of circuit breaker
(select from the previous page)

2 Control source, auxiliary contacts and connector

3 Accessories

※ In case of selecting 3 Accessories, only type Symbol 'A' once. (ex. A18A)

Order form for circuit breaker

Please select only one item per line. (* Required selection)

ULV, VCB, Draw-out type

(no extra charge extra charge)

1 Type of VCB from selection table*	Quantity	ea
2 Accessories		
Motor* (Mx)		page 164
<input type="radio"/> M2 DC 200V ~ 250V	<input type="radio"/> M3 DC 125V	<input type="radio"/> M4 DC 24V ~ 30V
<input type="radio"/> M5 DC 48V ~ 60V	<input type="radio"/> M6 AC 48V	<input type="radio"/> M7 AC 100V ~ 130V
<input type="radio"/> M8 AC 200V ~ 250V		
Closing coil* (Cx)		page 165
<input type="radio"/> C2 DC 200V ~ 250V	<input type="radio"/> C3 DC 125V	<input type="radio"/> C4 DC 24V ~ 30V
<input type="radio"/> C5 DC 48V ~ 60V	<input type="radio"/> C6 AC 48V	<input type="radio"/> C7 AC 100V ~ 130V
<input type="radio"/> C8 AC 200V ~ 250V		
Shunt trip coil* (Tx)		page 166
<input type="radio"/> T2 DC 200V ~ 250V	<input type="radio"/> T3 DC 125V	<input type="radio"/> T4 DC 24V ~ 30V
<input type="radio"/> T5 DC 48V ~ 60V	<input type="radio"/> T6 AC 48V	<input type="radio"/> T7 AC 100V ~ 130V
<input type="radio"/> T8 AC 200V ~ 250V		
Auxiliary contacts & Connector type*		page 169
<input type="radio"/> SQ2(4a4b, Q-type)	<input type="radio"/> SQ4(10a10b, Q-type)	
Under voltage release (Ux)		page 170
<input type="radio"/> U0 Without UVT		
※ Even without UVT, U0 must be selected to make VCB ordering code and description		
<small>Note) 1. In case of DC24V control source(M4, C4, T4), it is recommended to be used through Rated Control Voltage. 2. SB2 and SB4 have been updated to SQ2 and SQ4. If you need the SB type, please contact your sales person or customer representative.</small>		
Secondary shunt trip coil		page 167
<input type="checkbox"/> A1 (Secondary shunt trip coil)	<input type="checkbox"/> A2 (Secondary shunt trip coil monitoring contact)	
※ In case of selecting A1, maximum auxiliary contacts are 9a9b		※ In case of selecting A2, maximum auxiliary contacts are 9a8b
Position switch		page 171
<input type="checkbox"/> A3 (Test: 1a1b, Service: 2b)	<input type="checkbox"/> A4 (Test: 2a, Service: 2a)	<input type="checkbox"/> A5 (Test: 1a1b, Service: 1a1b)
Keylock		page 172
<input type="checkbox"/> A7 (Keylock)	<input type="checkbox"/> AN (Kirk key, CN-22 type)	<input type="checkbox"/> AP (Kirk key, Double CAMLOCK type)
<input type="checkbox"/> AM (Kirk key, CAMLOCK type)		
Button padlock		page 173
<input type="checkbox"/> A8 (Button padlock)	<input type="checkbox"/> AX (Button padlock in open)	
Lead wire*		page 174
<input type="radio"/> AA (Lead wire)	<input type="radio"/> AB (User plug)	
※ In case of selecting Lead Wire as a cradle option, no need to select it with the breaker.		
Plug Interlock*		page 175
<input type="radio"/> AC		
Padlock*		page 175
<input type="radio"/> AD		
MOC operator*		page 176
<input type="radio"/> AE		

Combination table

U0	1	
U1~8		1
A1 & A2	1	

Auxiliary contact

Symbol	10a10b
Standard	10 NO, 10 NC
with A1	9 NO, 9 NC
with A2	9 NO, 8 NC

Accessories (Sold separately)

CTU (Coil test unit)		page 179
<input type="checkbox"/> 73873171221 CTU (Coil test unit)		
CTD (Condenser trip device)		page 180
<input type="checkbox"/> 76113143001 CTD (Condenser trip device) DC 125V		
<input type="checkbox"/> 76113143002 CTD (Condenser trip device) DC 250V		
UDC (UVT delay controller)		page 181
<input type="checkbox"/> 52773171282 UDC (UVT delay controller) AC/DC 100~130V		
<input type="checkbox"/> 52773171283 UDC (UVT delay controller) AC/DC 200~250V		
<input type="checkbox"/> 52773171281 UDC (UVT delay controller) DC 48~60V and AC 48V		

Order form

Full description for cradle

UVL type, Draw-out type

UVCL-15L32S20



① Type of cradle
(select from the previous page)

A13M



② Accessories

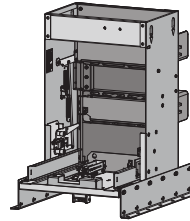

L-Type

Order form for cradle

Please select only one item per line. (* Required selection)

UVL, VCB, Draw-out type

(no extra charge extra charge)

① Type of VCB from selection table*		Quantity	ea
② Accessories			
Lead wire*			page 174
<input type="radio"/> A1 (4a4b)	<input type="radio"/> A2 (10a10b)		
Standard set (Shutter padlock, TOC, MOC)*			page 182~183
<input type="checkbox"/> A3 (4a4b)(MOC,TOC)			

Accessories (Sold separately)

Racking In/Out handle		page 189
<input type="checkbox"/> 55223181007 (Normal type of L-Cradle)		

4.76/15kV, 25/31.5kA, 1200A

UVL type, Draw-out type Arc type circuit breakers

[Unit: in(mm)]

Circuit breaker model

- UVL-05H25R12
- UVL-05H32R12
- UVL-15H25R12
- UVL-15H32R12

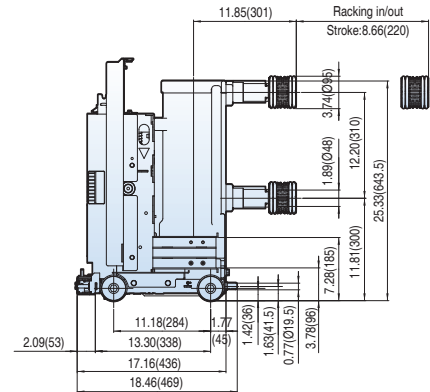
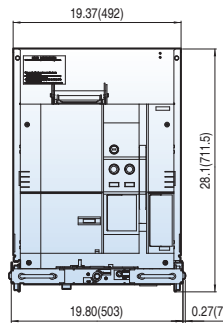
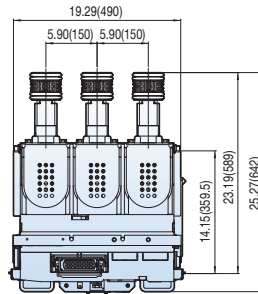

4.76/15kV, 25/31.5kA, 1200A

Circuit breaker model

- UVL-05H25S12
- UVL-05H32S12
- UVL-15H25S12
- UVL-15H32S12

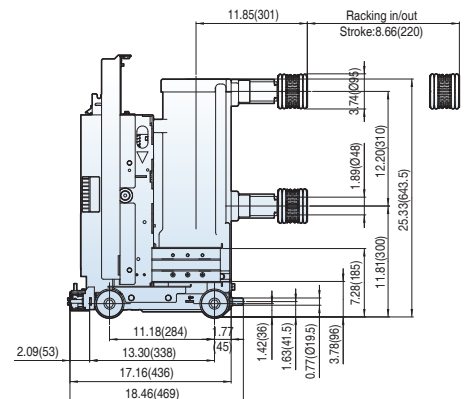
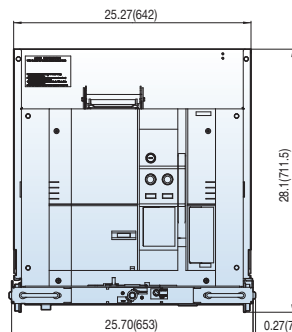
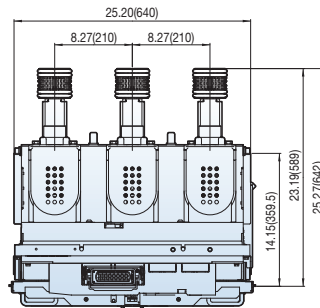

Dimensions

4.76/15kV, 25/31.5kA, 2000A

UVL type, Draw-out type
Arc type circuit breakers

[Unit: in(mm)]

Circuit breaker model

- UVL-05H25B20
- UVL-05H32B20
- UVL-15H25B20
- UVL-15H32B20

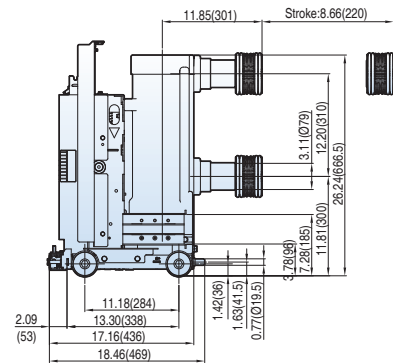
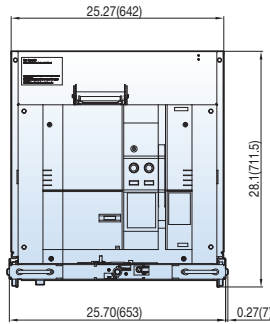
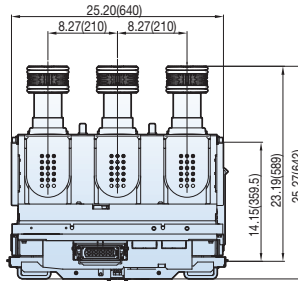

4.76/15kV, 25/31.5kA, 1200A

UVL type, Draw-out type Non-arc type circuit breakers

[Unit: in(mm)]

Circuit breaker model

- UVL-05H25B12
- UVL-05H32B12
- UVL-15H25B12
- UVL-15H32B12

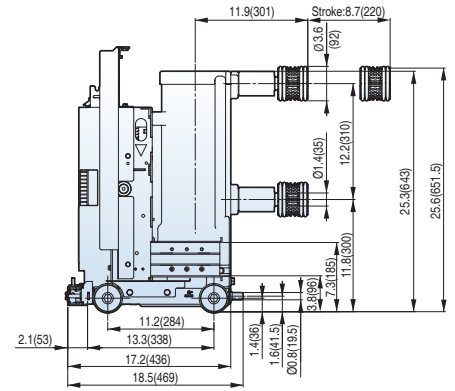
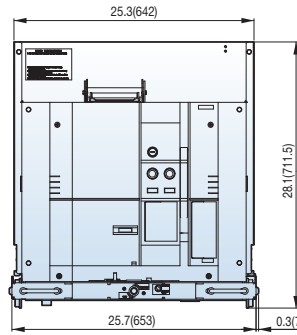
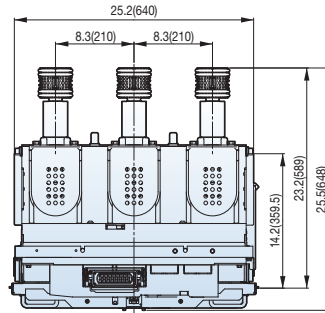

4.76/15kV, 25/31.5kA, 2000A

Circuit breaker model

- UVL-05H25S20
- UVL-05H32S20
- UVL-15H25S20
- UVL-15H32S20

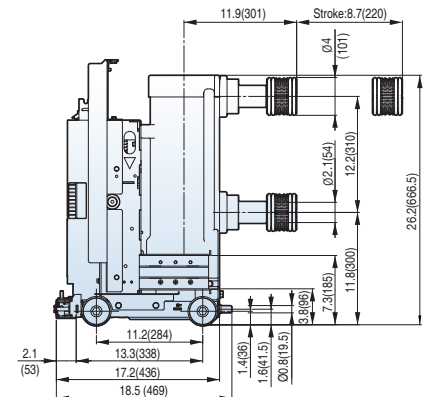
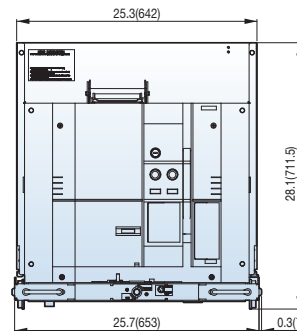
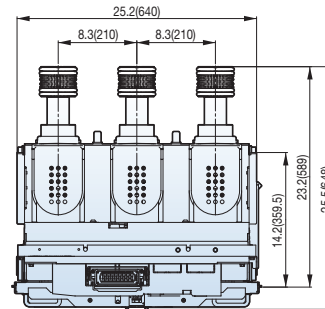

Dimensions

4.76/15kV, 25/31.5kA, 1200A

UVL type, Draw-out type Circuit breakers for L-type cradle

[Unit: in(mm)]

Circuit breaker model

- UVL-05H25A12
- UVL-05H32A12
- UVL-15H25A12
- UVL-15H32A12

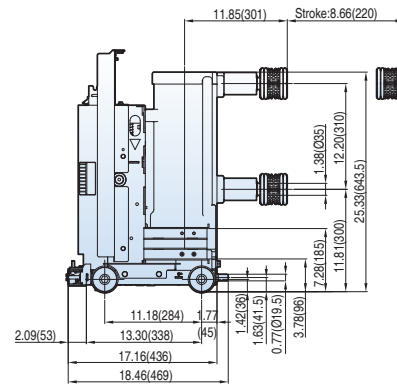
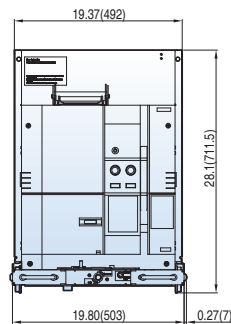
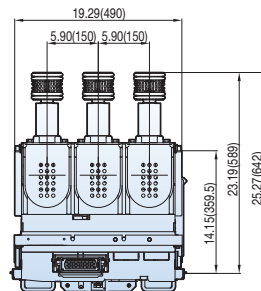

4.76/15kV, 25/31.5kA, 2000A

Circuit breaker model

- UVL-05H25S20
- UVL-05H32S20
- UVL-15H25S20
- UVL-15H32S20

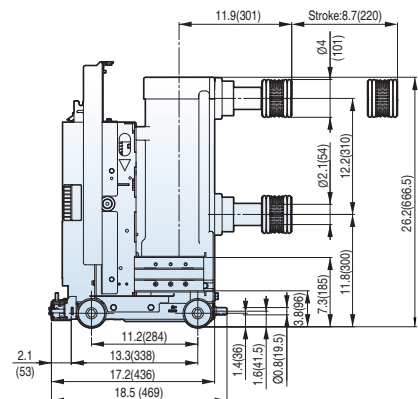
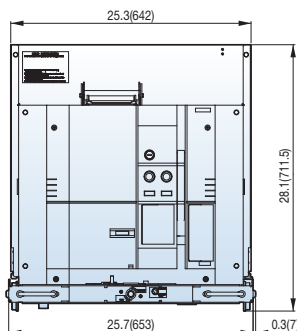
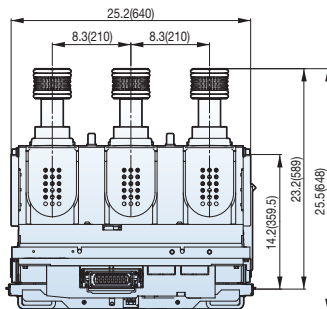

4.76/15kV, 25/31.5kA, 1200A

UVL type, Draw-out type

Cradle model

- UVCL-05L25P12
- UVCL-05L32P12
- UVCL-15L25P12
- UVCL-15L32P12

[Unit: in(mm)]

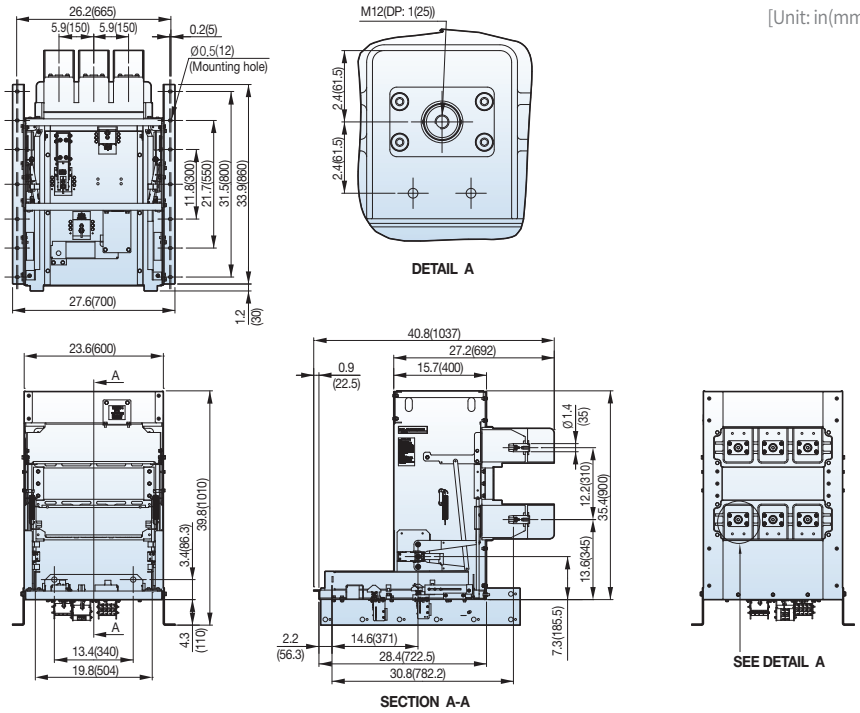

Cradle model

- UVCL-05L25S20
- UVCL-05L32S20
- UVCL-15L25S20
- UVCL-15L32S20

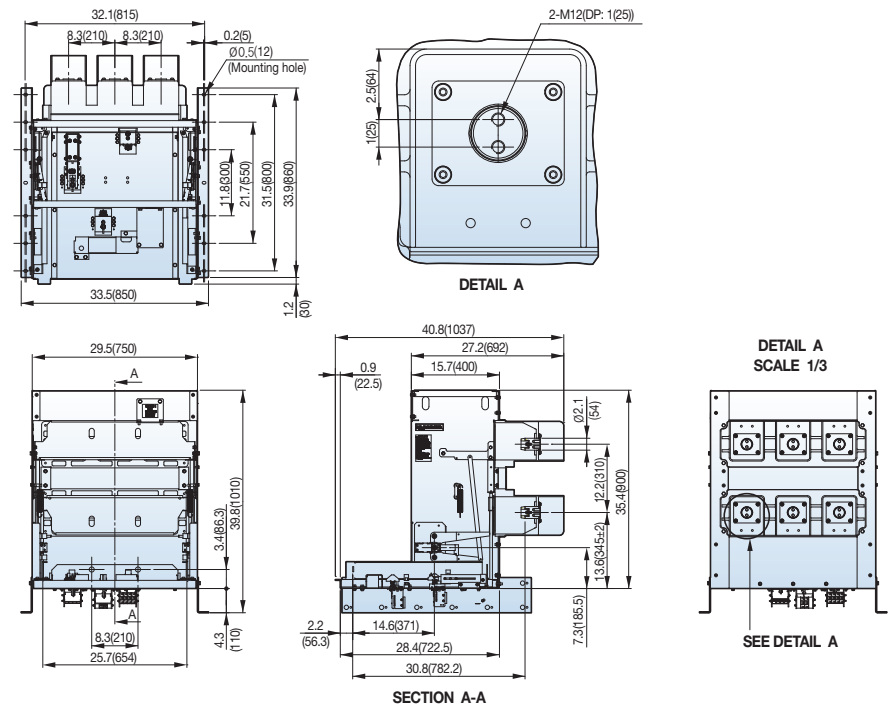

Memo

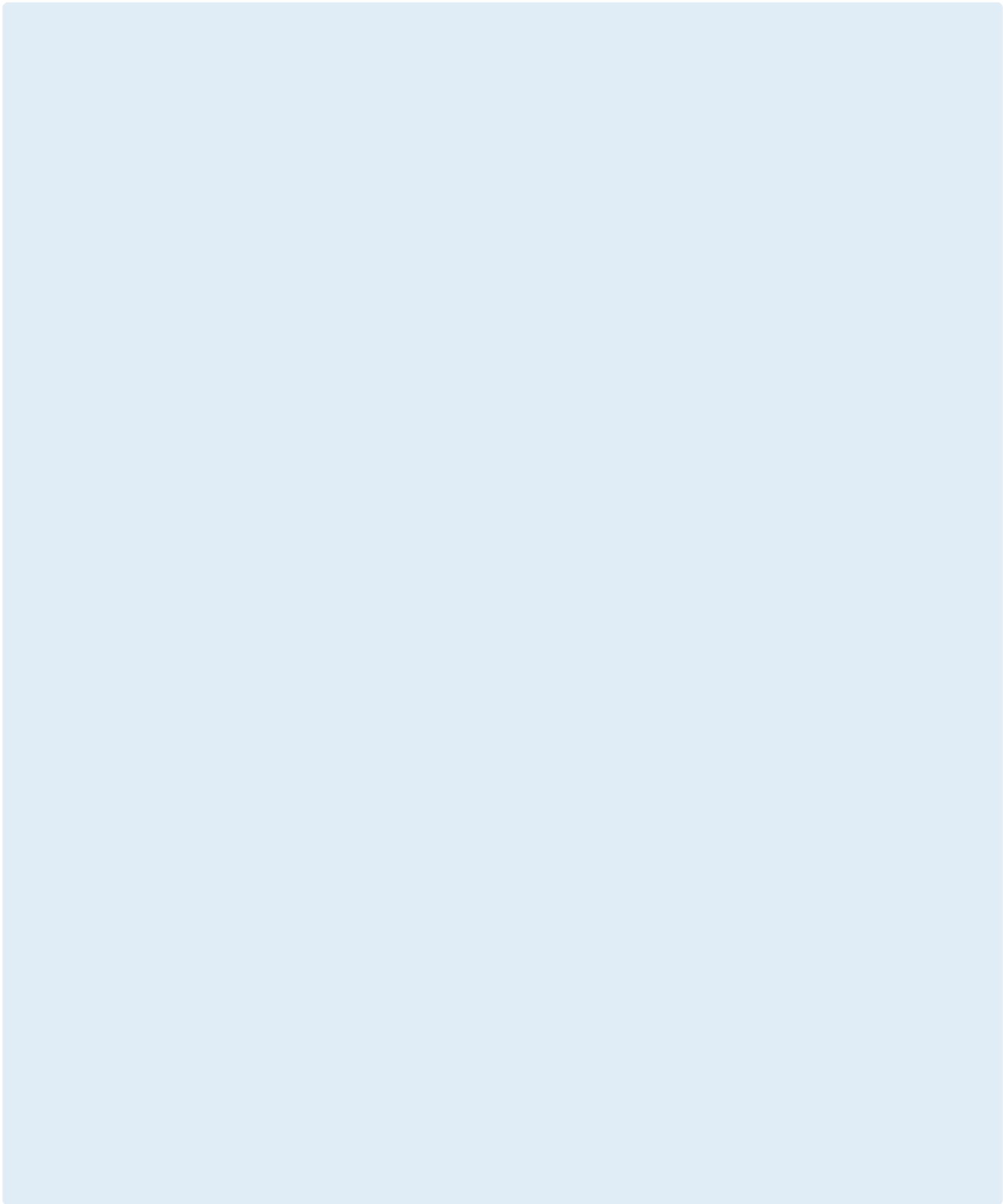

Susol UVM

Draw-out type
(Draw in/out by using screw)



Contents

▪ Ratings and description	56
▪ Selection guide	58
▪ Order form	60
▪ Dimensions	62

Ratings and description

UVM type, Draw-out type



UVM-05H / UVM-15H

Circuit breaker type		UVM-05H				UVM-15H			
Rated voltage	Ur (kV)	4.76				15			
Rated withstand voltage	Power frequency (1min)	19				36			
	Lightening impulse (1.2×50µs)	60				95			
Rated short-circuit current	Isc (kA)	25	31.5		25	31.5			
Rated normal current	Ir (A)	1200	2000	1200	2000	1200	2000	1200	2000
Rated frequency	fr (Hz)	60	60	60	60	60	60	60	60
Rated short-circuit making current	Ip (kA) at 60 Hz	65	65	81.9	81.9	65	65	81.9	81.9
Rated short-time withstand current	Ik (kA)	25	25	31.5	31.5	25	25	31.5	31.5
	3sec	●	●	●	●	●	●	●	●
Operating sequence	O - 0.3s - CO - 15s - CO	●	●	●	●	●	●	●	●

Technical data

Opening time		Less than 0.04 sec
Rated breaking time		3 Cycle
No-load closing time		Less than 0.06 sec
Test class	Mechanical endurance	M2 (10,000)
	Electrical endurance	Reference standard (page 210)
	Capacitance	C2
Operating temperature	Low	-40 °C
	High	40 °C



Circuit breaker type		UVM-27H	
Rated voltage	Ur (kV)	27	
Rated withstand voltage	Power frequency (1min)	Ud (kV)	60
	Lightening impulse (1.2×50μs)	Up (kV)	125
Rated short-circuit current	Isc (kA)	25	
Rated normal current	Ir (A)	1200	2000
Rated frequency	fr (Hz)	60	60
Rated short-circuit making current	I _p (kA) at 50 Hz	-	-
	I _p (kA) at 60 Hz	65	65
Rated short-time withstand current	I _k (kA)	25	25
	3sec	●	●
Operating sequence	O - 0.3s - CO - 15s - CO	●	●

Technical data

Opening time	Less than 0.04 sec	
Rated breaking time	3 Cycle	
No-load closing time	Less than 0.07 sec	
Test class	Mechanical endurance	M2 (10,000)
	Electrical endurance	Reference standard (page 210)
	Capacitance	C2
Operating temperature	Low	-40 °C
	High	40 °C

Selection guide

Description for circuit breaker type

UVM type, Draw-out type

Withdrawal VCB, Cradle for MCSG

UVM		15		H		32		A		12	
Model		Rated voltage (kV)		Type		Interrupting current (kA)		Phase distance		Rated current (A)	
UVM	Susol VCB	05	4.76	H	Draw-out Type (For UVM, UVH MCSG)	25	25	A	7in(178mm)	12	1200
		15	15			32	31.5	C	10in(254mm)	20	2000
		27	27	H	H type Draw-out (for MCSG)	25	25	C	10in(254mm)	12	1200
										20	2000

Selection table of circuit breaker type

Select withdrawal VCB/Cradle with same horizontal line.

Ur [kV]	Isc [kA]	Ir [A]		Circuit breaker Model	Weight [lb]	Outline dimension H×W×D [in]	Dimension page
		p = 7"	p = 10"				
4.76	25	1200	2000	UVM-05H25A12	220.46	26.7×21.8×28.9	62
				UVM-05H25A20	286.6	26.7×21.8×28.9	64
		1200	2000	UVM-05H25C12	264.55	26.7×31.8×28.9	62
	UVM-05H25C20			330.69	26.7×31.8×28.9	64	
	31.5	1200	2000	UVM-05H32A12	220.46	26.7×21.8×28.9	63
				UVM-05H32A20	286.6	26.7×21.8×28.9	64
1200		2000	UVM-05H32C12	264.55	26.7×31.8×28.9	63	
	UVM-05H32C20		330.69	26.7×31.8×28.9	64		
15	25	1200	2000	UVM-15H25A12	220.46	26.7×21.8×28.9	62
				UVM-15H25A20	286.6	26.7×21.8×28.9	64
		1200	2000	UVM-15H25C12	264.55	26.7×31.8×28.9	62
	UVM-15H25C20			330.69	26.7×31.8×28.9	64	
	31.5	1200	2000	UVM-15H32A12	220.46	26.7×21.8×28.9	63
				UVM-15H32A20	286.6	26.7×21.8×28.9	64
1200		2000	UVM-15H32C12	264.55	26.7×31.8×28.9	63	
	UVM-15H32C20		330.69	26.7×31.8×28.9	64		
27	25			UVM-27H25C12	286.6	33.9×31.8×30.9	65
				UVM-27H25C20	330.69	33.9×31.8×30.9	65

Description for Cradle

UVM type, Draw-out type



H type

UVCVM		15	H	32	A	12
Model		Rated voltage (kV)	Type	Interrupting current (kA)	Phase distance	Rated current (A)
UVCVM	Susol UL VCB Cradle (UVCVM)	5	L MCSG Cradle type	25	A 7in(178mm)	12
		4.76	C Compact type Draw-out(for MCSG)	25	C 10in(254mm)	1200
		15	H H type Draw-out (for MCSG)	32		20
						2000
		27	L MCSG Cradle type	25	C 10in(254mm)	12
			C Compact type Draw-out(for MCSG)	25		1200
			H H type Draw-out (for MCSG)			20
						2000

Selection table of cradle

Ur [kV]	Isc [kA]	Ir [A]		Arc resistance	Cradle model □ = [L,C,H]	Outline dimension H×W×D [in]			Dimension by type page		
		p = 7"	p = 10"			L - type	C - type	H - type	L	C	H
4.76	25	1200	-	UVCVM-05□25A12	36.4×26×47.3	41.7×26×56.9	41.7×26×57.3	66	68	72	
		2000	-	UVCVM-05□25A20	36.4×26×47.3	41.7×26×56.9	41.7×26×57.3	74	70	76	
	31.5	1200	-	UVCVM-05□25C12	36.4×36×47.3	41.7×36×56.9	41.7×36×57.3	67	69	73	
		2000	-	UVCVM-05□25C20	36.4×36×47.3	41.7×36×56.9	41.7×36×57.3	75	71	77	
	25	1200	-	UVCVM-05□32A12	36.4×26×47.3	41.7×26×56.9	41.7×26×57.3	66	68	72	
		2000	-	UVCVM-05□32A20	36.4×26×47.3	41.7×26×56.9	41.7×26×57.3	74	70	76	
15	25	1200	-	UVCVM-05□32C12	36.4×36×47.3	41.7×36×56.9	41.7×36×57.3	67	69	73	
		2000	-	UVCVM-05□32C20	36.4×36×47.3	41.7×36×56.9	41.7×36×57.3	75	71	77	
	31.5	1200	-	UVCVM-15□25A12	36.4×26×47.3	41.7×26×56.9	41.7×26×57.3	66	68	72	
		2000	-	UVCVM-15□25A20	36.4×26×47.3	41.7×26×56.9	41.7×26×57.3	74	70	76	
	25	1200	-	UVCVM-15□25C12	36.4×36×47.3	41.7×36×56.9	41.7×36×57.3	67	69	73	
		2000	-	UVCVM-15□25C20	36.4×36×47.3	41.7×36×56.9	41.7×36×57.3	75	71	77	
27	25	1200	-	UVCVM-15□32A12	36.4×26×47.3	41.7×26×56.9	41.7×26×57.3	66	68	72	
		2000	-	UVCVM-15□32A20	36.4×26×47.3	41.7×26×56.9	41.7×26×57.3	74	70	76	
		1200	-	UVCVM-15□32C12	36.4×36×47.3	41.7×36×56.9	41.7×36×57.3	67	69	73	
		2000	-	UVCVM-15□32C20	36.4×36×47.3	41.7×36×56.9	41.7×36×57.3	75	71	77	
		1200	-	UVCVM-27□25C12	44×36×52.9	46.3×36×62.5	46.3×36×62.9	78	80	82	
		2000	-	UVCVM-27□25C20	44×36×52.9	46.3×36×62.5	46.3×36×62.9	79	81	83	

Order form

Full description for circuit breaker

UVM type, Draw-out type

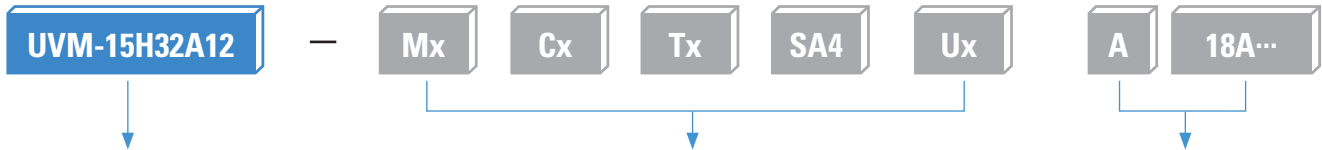

1 Type of circuit breaker
(select from the previous page)

2 Control source, auxiliary contacts and connector

3 Accessories

※ In case of selecting 3 Accessories, only type Symbol 'A' once. (ex. A18A)

Order form for circuit breaker

Please select only one item per line. (* Required selection)

UVM, VCB, Draw-out type

(No extra charge extra charge)

1 Type of VCB from selection table*		Quantity	ea
2 Accessories			
Motor* (Mx)			page 164
<input type="radio"/> M2	<input type="radio"/> M3	<input type="radio"/> M4	<input type="radio"/> M5
DC 200V ~ 250V	DC 125V	DC 24V ~ 30V	DC 48V ~ 60V
<input type="radio"/> M6	<input type="radio"/> M7	<input type="radio"/> M8	
AC 48V	AC 100V ~ 130V	AC 200V ~ 250V	
Closing coil* (Cx)			page 165
<input type="radio"/> C2	<input type="radio"/> C3	<input type="radio"/> C4	<input type="radio"/> C5
DC 200V ~ 250V	DC 125V	DC 24V ~ 30V	DC 48V ~ 60V
<input type="radio"/> C6	<input type="radio"/> C7	<input type="radio"/> C8	
AC 48V	AC 100V ~ 130V	AC 200V ~ 250V	
Shunt trip coil* (Tx)			page 166
<input type="radio"/> T2	<input type="radio"/> T3	<input type="radio"/> T4	<input type="radio"/> T5
DC 200V ~ 250V	DC 125V	DC 24V ~ 30V	DC 48V ~ 60V
<input type="radio"/> T6	<input type="radio"/> T7	<input type="radio"/> T8	
AC 48V	AC 100V ~ 130V	AC 200V ~ 250V	
Auxiliary contacts & Connector type*			page 169
<input type="radio"/> SC2 (4a4b, Auto-con type)		<input type="radio"/> SC4 (10a10b, Auto-con type)	
Under Voltage Release (Ux)			page 170
<input type="radio"/> U0*	<input type="checkbox"/> U2	<input type="checkbox"/> U3	<input type="checkbox"/> U4
Without UVT	DC 200V ~ 250V	DC 125V	DC 24V ~ 30V
<input type="checkbox"/> U5	<input type="checkbox"/> U6	<input type="checkbox"/> U7	<input type="checkbox"/> U8
DC 48V ~ 60V	AC 48V	AC 100V ~ 130V	AC 200V ~ 250V
※ Even without UVT, U0 must be selected to make VCB ordering code and description			
Note) In case of DC24V control source(M4, C4, T4, U4), it is recommended to be used through Rated Control Voltage.			
Secondary shunt trip coil			page 167
<input type="checkbox"/> A1 (Secondary shunt trip coil)		<input type="checkbox"/> A2 (Secondary shunt trip coil monitoring contact)	
※ In case of selecting A1, maximum auxiliary contacts are 9a9b		※ In case of selecting A2, maximum auxiliary contacts are 9a8b	
Keylock			page 172
<input type="checkbox"/> A7 (Keylock)		<input type="checkbox"/> AN (Kirk key, CN-22 type)	
<input type="checkbox"/> AM (Kirk key, CAMLOCK type)		<input type="checkbox"/> AP (Kirk key, Double CAMLOCK type)	
Button padlock			page 173
<input type="checkbox"/> A8 (Button padlock)		<input type="checkbox"/> AX (Button padlock in open)	
MOC operator*			page 176
<input type="checkbox"/> AE			
Auxiliary wheels (Direct roll-in)			page 177
<input type="checkbox"/> AS			

Combination table

U0	1	
U1-8		1
A1 & A2	1	

Auxiliary contact

Symbol	10a10b
Standard	10 NO, 10 NC
with A1	9 NO, 9 NC
with A2	9 NO, 8 NC

Accessories (Sold separately)

CTU (Coil test unit)	<input type="checkbox"/> 73873171221 CTU (Coil test unit)	page 179
CTD (Condenser trip device)	<input type="checkbox"/> 76113143001 CTD (Condenser trip device) DC 125V <input type="checkbox"/> 76113143002 CTD (Condenser trip device) DC 250V	page 180
UDC (UVT delay controller)	<input type="checkbox"/> 52773171282 UDC (UVT delay controller) AC/DC 100-130V <input type="checkbox"/> 52773171283 UDC (UVT delay controller) AC/DC 200-250V <input type="checkbox"/> 52773171281 UDC (UVT delay controller) DC 48-60V and AC 48V	page 181

Full description for cradle

UVM type, Draw-out type

UVCM-05L25A12

① Type of cradle
(select from the previous page)

A **13567A**

② Accessories

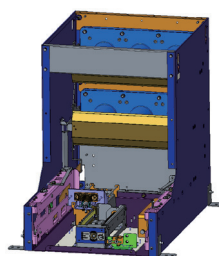

L type



C type



H type

Order form for cradle

Please select only one item per line. (* Required selection)

UVM, VCB, Draw-out type

(no extra charge extra charge)

① Type of Cradle from selection table*	Quantity	ea
② Accessories		
Lead wire*		page 174
<input type="checkbox"/> A1 (4a4b)	<input type="checkbox"/> A2 (10a10b)	
Standard set (Shutter padlock, TOC, MOC)*		page 182 ~ 183
<input type="checkbox"/> A3 (6a6b(MOC,TOC))	<input type="checkbox"/> A4 (12a12b(MOC,TOC))	
※ In case of selecting Remote Racking System, Maximum contacts of MOC are 4a4b.		※ In case of selecting Remote Racking System, Maximum contacts of MOC are 10a10b.
Padlock (Only for C, H type cradle)		page 183
<input type="checkbox"/> A5		
Door (Only for C, H type cradle)		page 184
<input type="checkbox"/> A6		
Door interlock (Only for C, H type cradle)		page 185
<input type="checkbox"/> A7		
Kirk key interlock		page 184
<input type="checkbox"/> A9		
※ In case of selecting Remote Racking System, A9 must be selected to make cradle ordering code and description. The Kirk-key is not provided separately.		
Remote racking system (Only for C, H type cradle)		page 187
<input type="checkbox"/> AA (AC120V, Without OPEN, CLOSE Function)	<input type="checkbox"/> AB (AC240V, Without OPEN, CLOSE Function)	
<input type="checkbox"/> AC (DC125V, Without OPEN, CLOSE Function)	<input type="checkbox"/> AD (DC250V, Without OPEN, CLOSE Function)	
<input type="checkbox"/> AE (AC120V, With OPEN, CLOSE Function)	<input type="checkbox"/> AF (AC240V, With OPEN, CLOSE Function)	
<input type="checkbox"/> AG (DC125V, With OPEN, CLOSE Function)	<input type="checkbox"/> AH (DC250V, With OPEN, CLOSE Function)	

Accessories (Sold separately)

Racking In/Out handle		page 189 ~ 191
<input type="checkbox"/> 55223181007 (Normal type of L-Cradle)	<input type="checkbox"/> 55223181002 (Universal type of H-Cradle for MCRS)	
<input type="checkbox"/> 55223181001 (Universal type of H-Cradle)	<input type="checkbox"/> 55223181004 (Universal type of C-Cradle for MCRS)	
<input type="checkbox"/> 55223181003 (Universal type of C-Cradle)		
Extension rail		page 192
<input type="checkbox"/> 59023181003		

Dimensions

4.76/15kV, 25kA, 1200A

UVM type, Draw-out type

[Unit: in(mm)]

Circuit breaker model

UVM-05H25A12
UVM-15H25A12

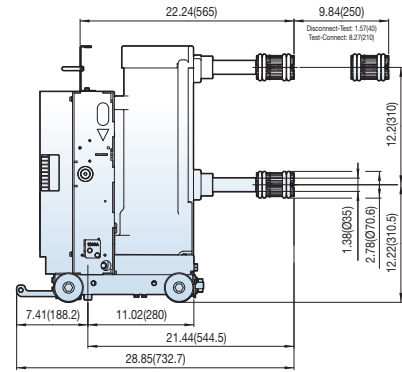
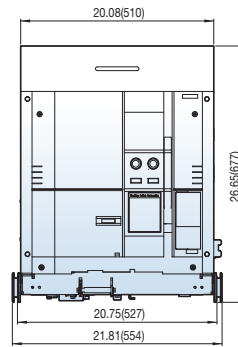
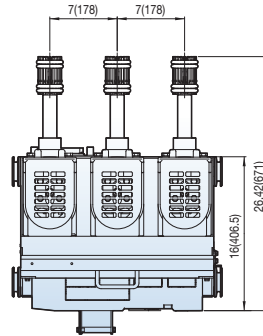

Circuit breaker model

UVM-05H25C12
UVM-15H25C12

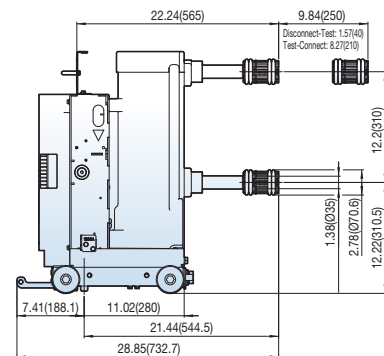
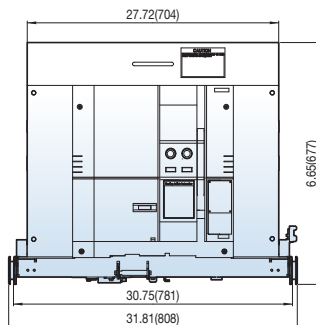
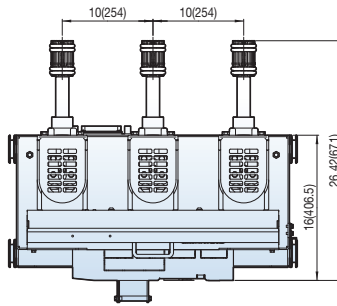

4.76/15kV, 31.5kA, 1200A

VVM type, Draw-out type

Circuit breaker model

UVM-05H32A12
UVM-15H32A12

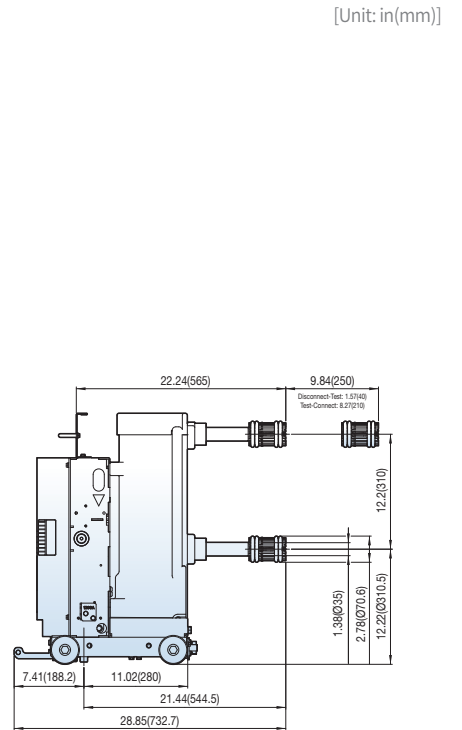
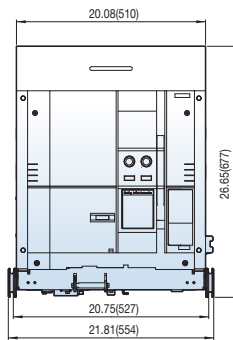
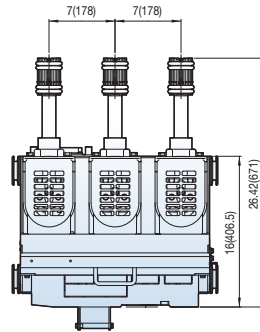

Circuit breaker model

UVM-05H32C12
UVM-15H32C12

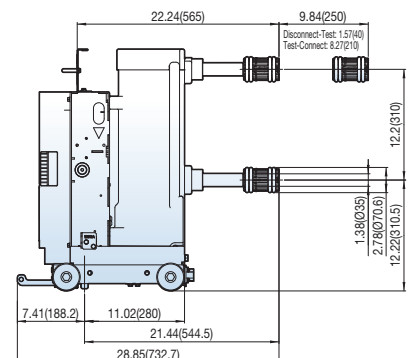
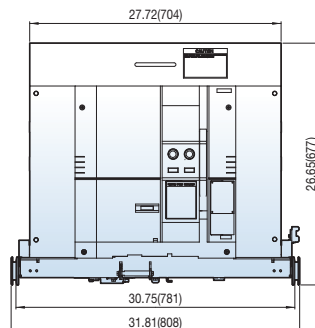
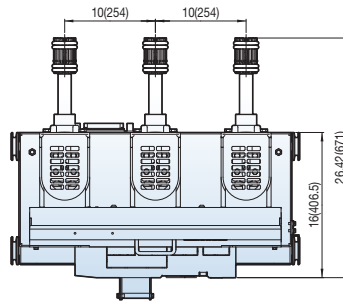

Dimensions

4.76/15kV, 25/31.5kA, 2000A

UVM type, Draw-out type

[Unit: in(mm)]

Circuit breaker model

- UVM-05H25A20
- UVM-05H32A20
- UVM-15H25A20
- UVM-15H32A20

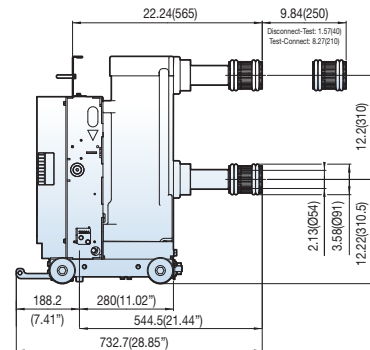
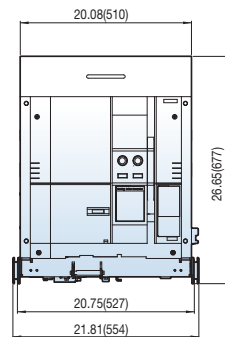
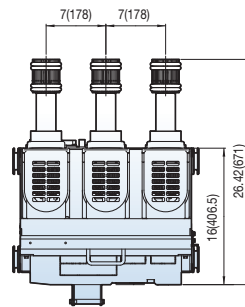

Circuit breaker model

- UVM-05H25C20
- UVM-05H32C20
- UVM-15H25C20
- UVM-15H32C20

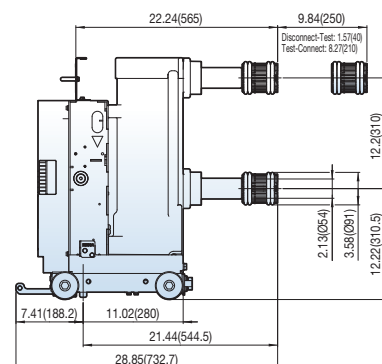
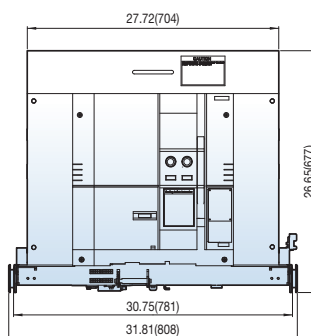
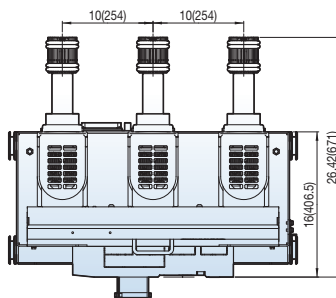

27kV, 25kA, 1200A

VVM type, Draw-out type

Circuit breaker model

UVM-27H25C12

[Unit: in(mm)]

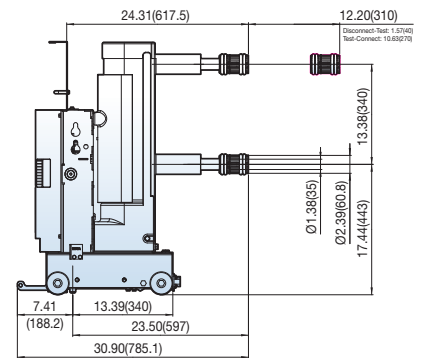
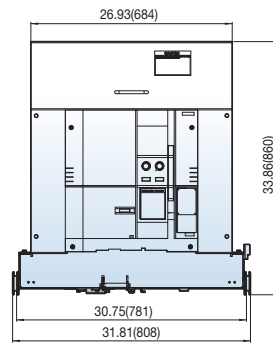
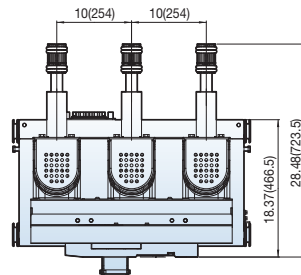

27kV, 25kA, 2000A

Circuit breaker model

UVM-27H25C20

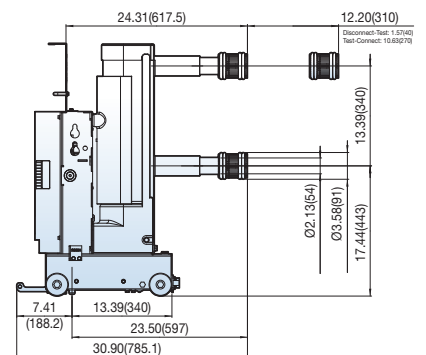
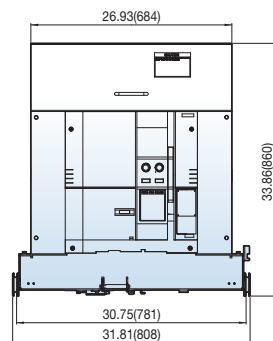
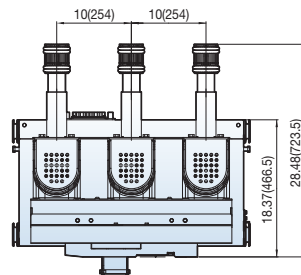

Dimensions

4.76/15kV, 25/31.5kA, 1200A

UVM type, Draw-out type

Cradle model

- UVCM-05L25A12
- UVCM-05L32A12
- UVCM-15L25A12
- UVCM-15L32A12

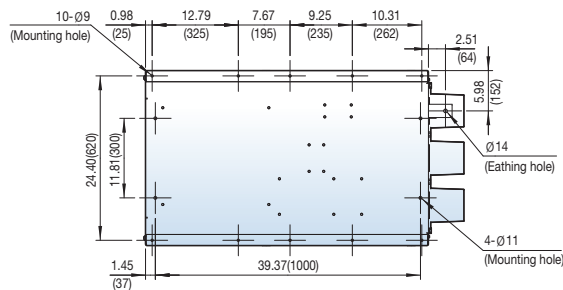
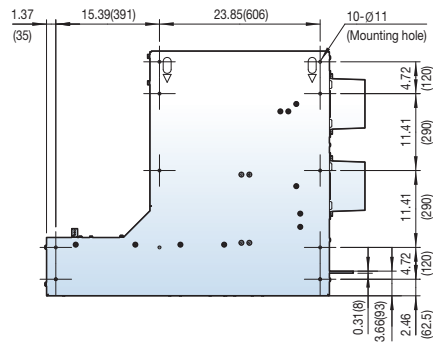
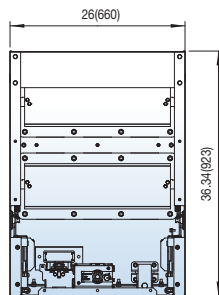
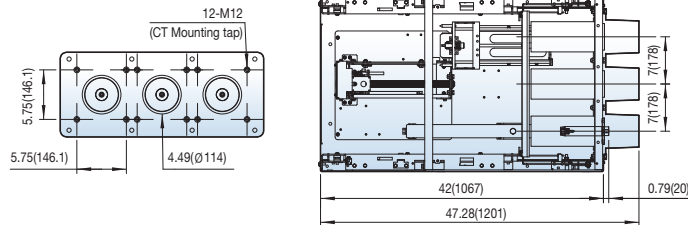

[Unit: in(mm)]

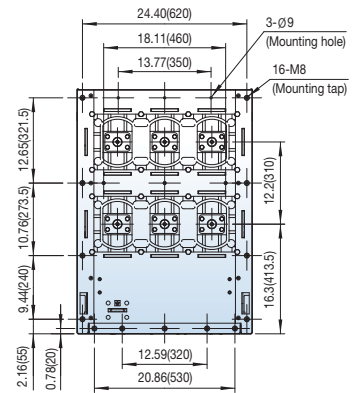
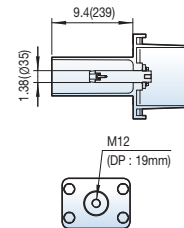

4.76/15kV, 25/31.5kA, 1200A

UVM type, Draw-out type

Cradle model

- UVCN-05L25C12
- UVCN-05L32C12
- UVCN-15L25C12
- UVCN-15L32C12

[Unit: in(mm)]

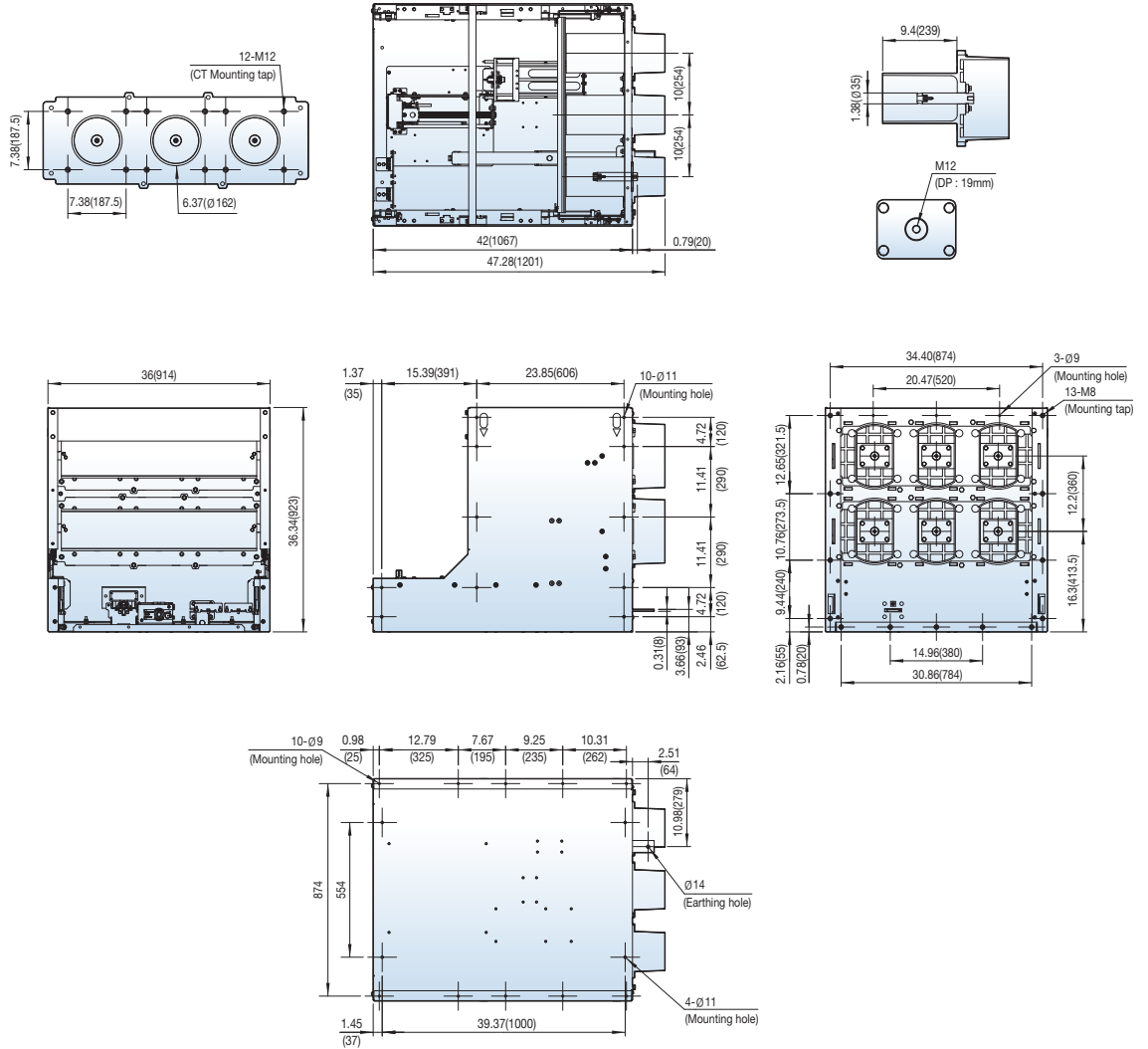

Dimensions

4.76/15kV, 25/31.5kA, 1200A

UVM type, Draw-out type

Cradle model

- UVCM-05C25A12
- UVCM-05C32A12
- UVCM-15C25A12
- UVCM-15C32A12

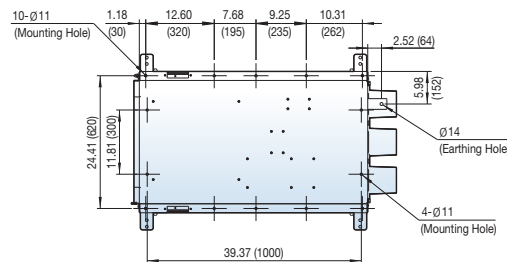
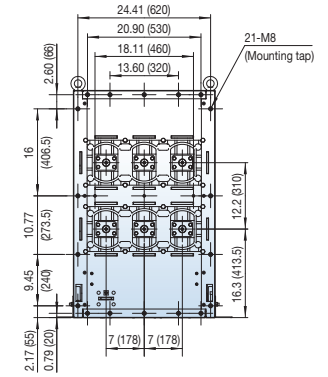
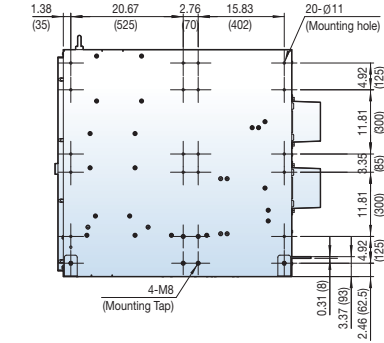
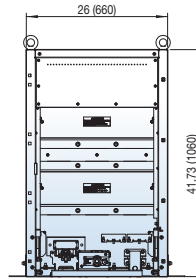
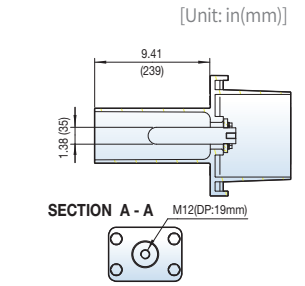
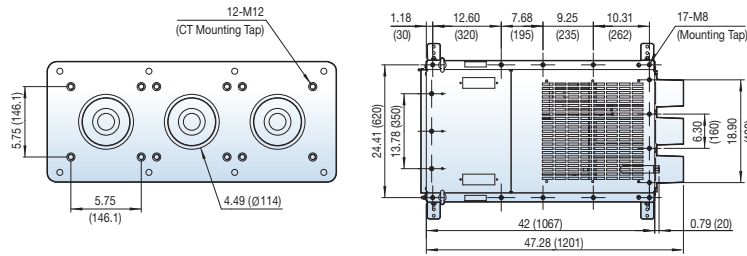

4.76/15kV, 25/31.5kA, 1200A

VVM type, Draw-out type

Cradle model

- UVCN-05C25C12
- UVCN-05C32C12
- UVCN-15C25C12
- UVCN-15C32C12

[Unit: in(mm)]

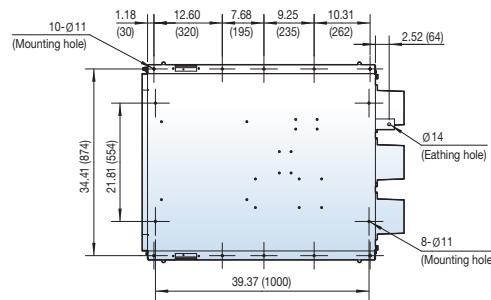
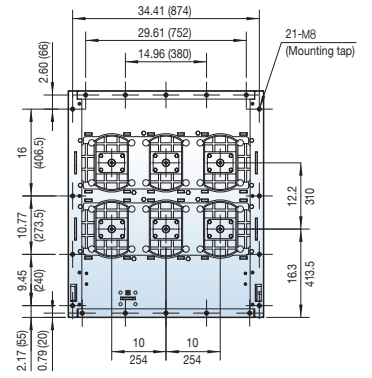
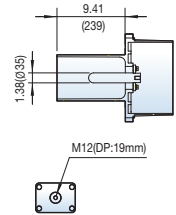
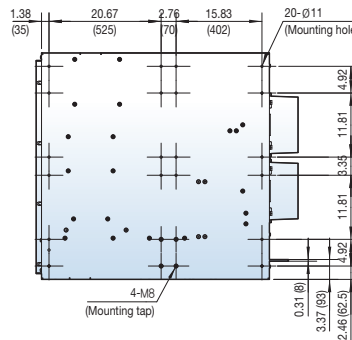
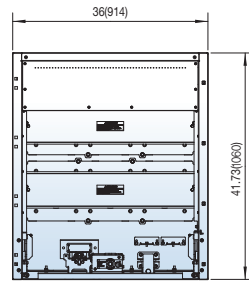
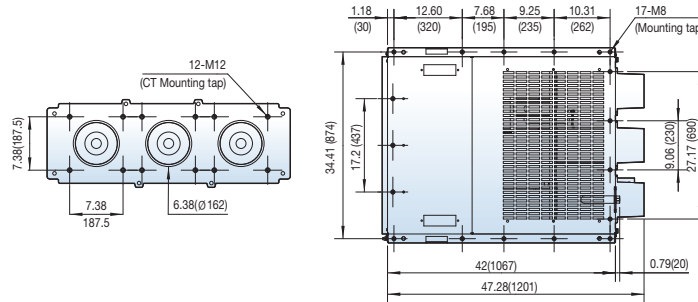

Dimensions

4.76/15kV, 25/31.5kA, 2000A

UVM type, Draw-out type

Cradle model

- UVCM-05C25A20
- UVCM-05C32A20
- UVCM-15C25A20
- UVCM-15C32A20

[Unit: in(mm)]

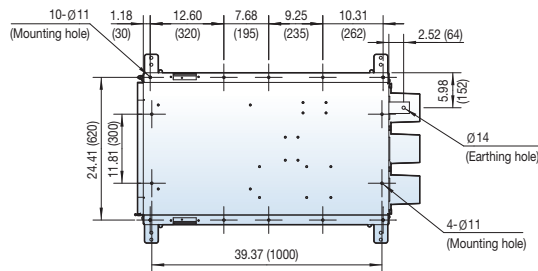
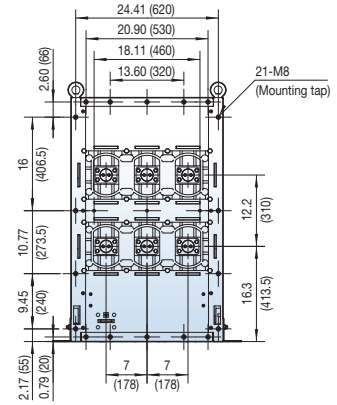
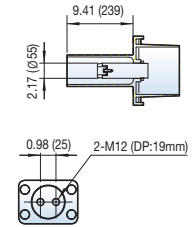
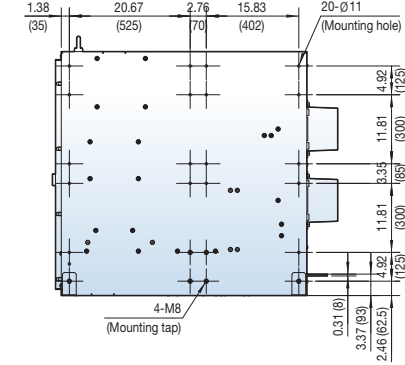
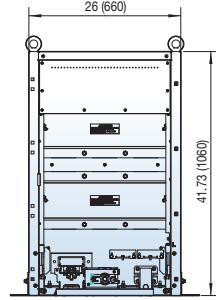
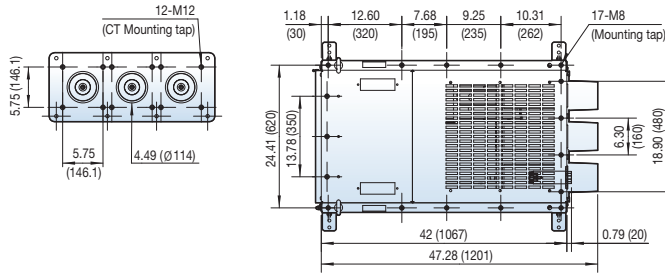

4.76/15kV, 25/31.5kA, 2000A

UVM type, Draw-out type

Cradle model

- UVCN-05C25C20
- UVCN-05C32C20
- UVCN-15C25C20
- UVCN-15C32C20

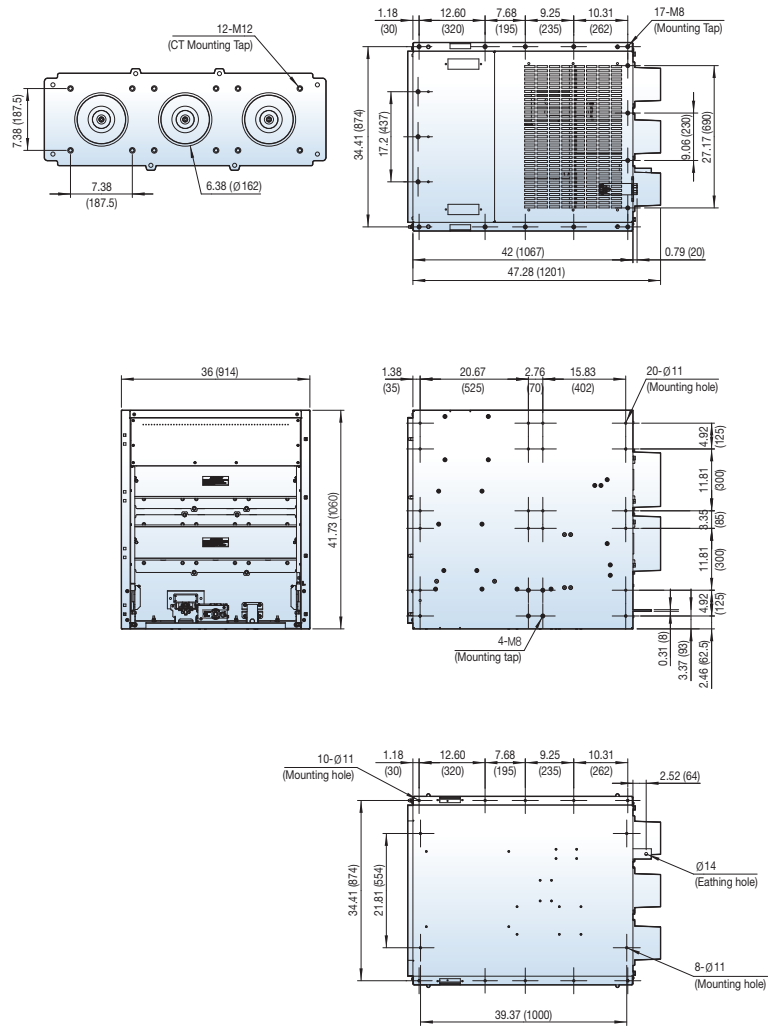

[Unit: in(mm)]

Dimensions

4.76/15kV, 25/31.5kA, 1200A

UVM type, Draw-out type

Cradle model

- UVCM-05H25A12
- UVCM-05H32A12
- UVCM-15H25A12
- UVCM-15H32A12

[Unit: in(mm)]

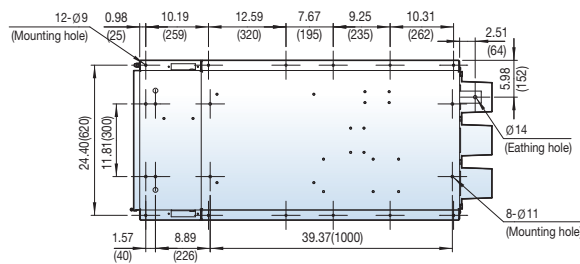
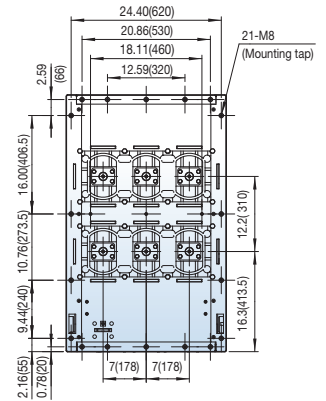
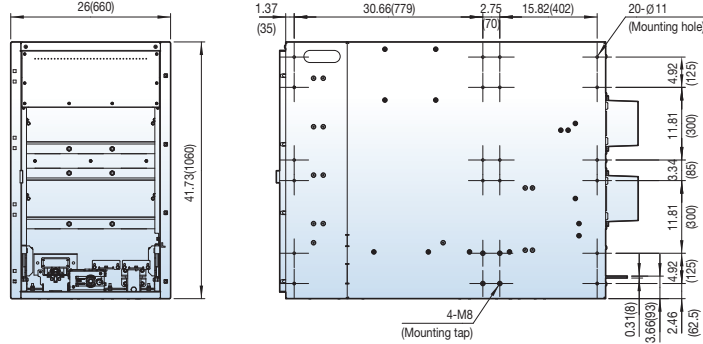
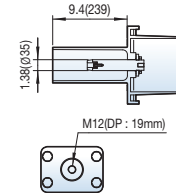
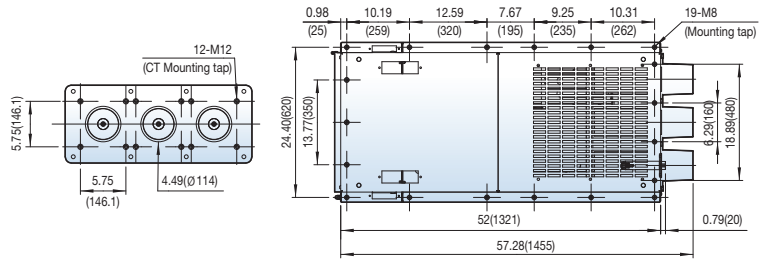

4.76/15kV, 25/31.5kA, 1200A

UVM type, Draw-out type

Cradle model

- UVCM-05H25C12
- UVCM-05H32C12
- UVCM-15H25C12
- UVCM-15H32C12

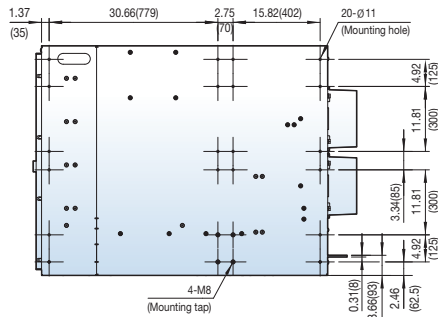
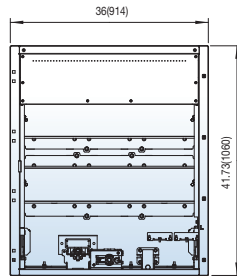
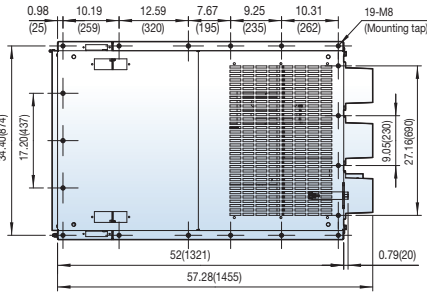
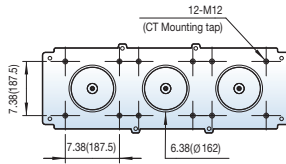

[Unit: in(mm)]

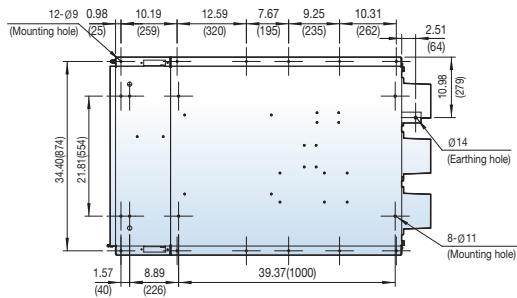
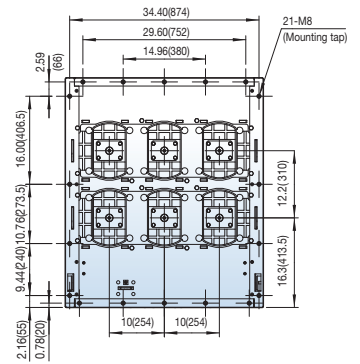
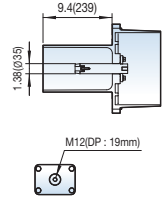

Dimensions

4.76/15kV, 25/31.5kA, 2000A

UVM type, Draw-out type

Cradle model

- UVCM-05L25A20
- UVCM-05L32A20
- UVCM-15L25A20
- UVCM-15L32A20

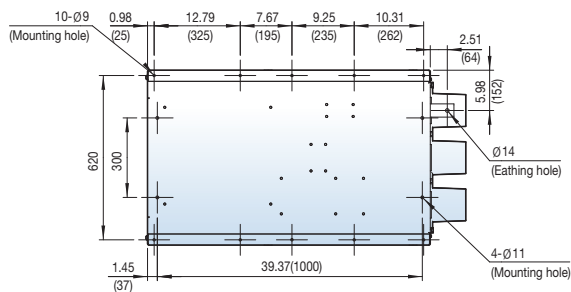
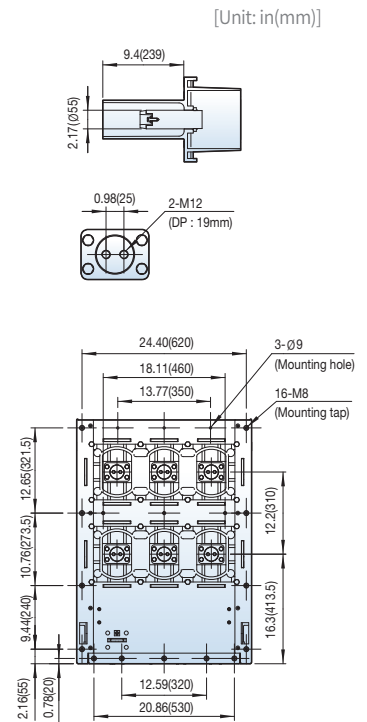
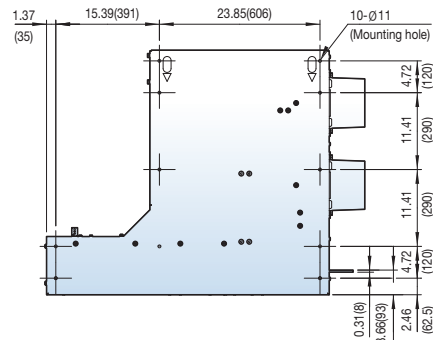
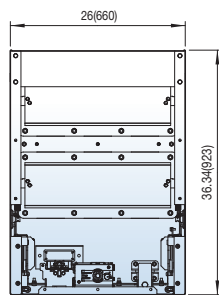
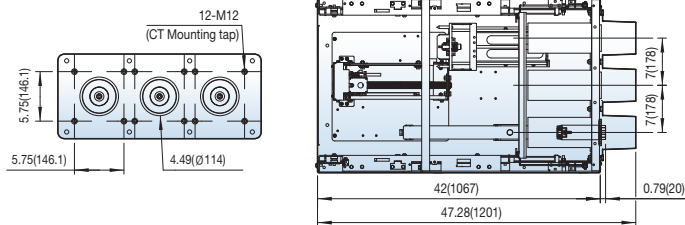

4.76/15kV, 25/31.5kA, 2000A

UVM type, Draw-out type

Cradle model

- UVCM-05L25C20
- UVCM-05L32C20
- UVCM-15L25C20
- UVCM-15L32C20

[Unit: in(mm)]

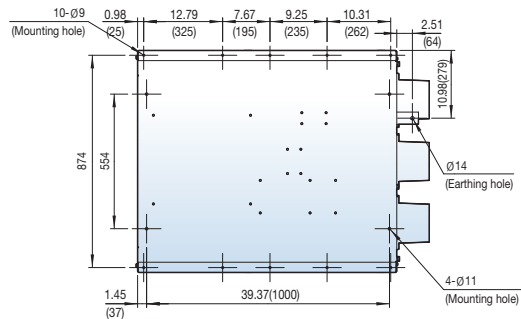
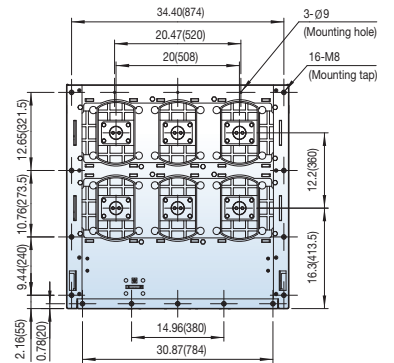
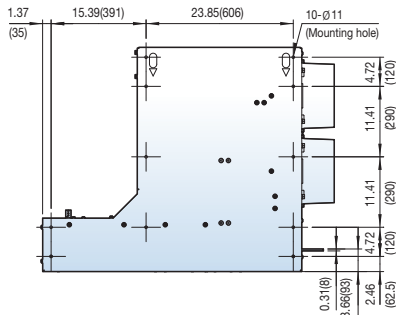
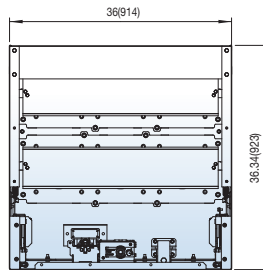
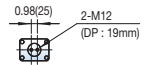
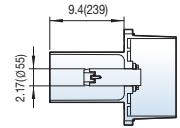
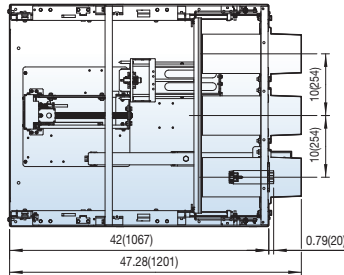
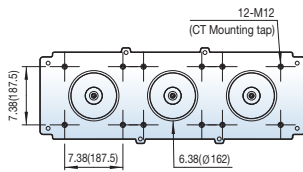

Dimensions

4.76/15kV, 25/31.5kA, 2000A

VVM type, Draw-out type

Cradle model

- UVCM-05H25A20
- UVCM-05H32A20
- UVCM-15H25A20
- UVCM-15H32A20

[Unit: in(mm)]

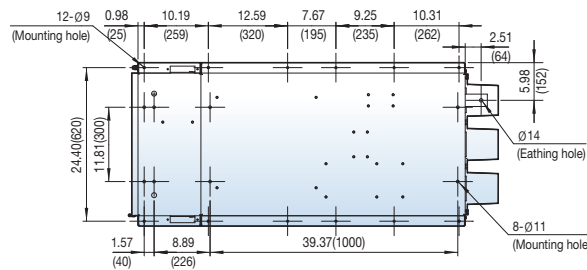
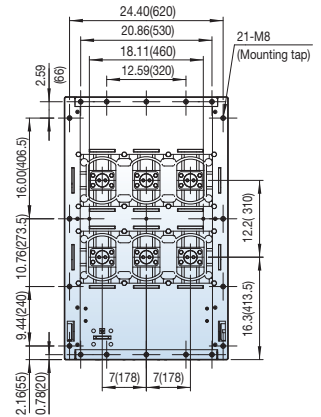
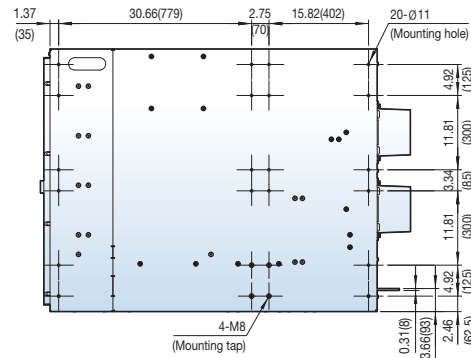
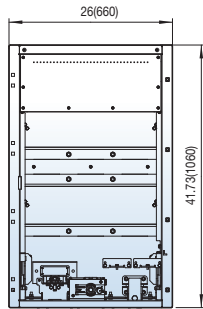
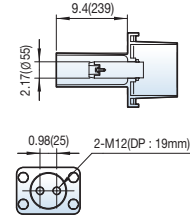
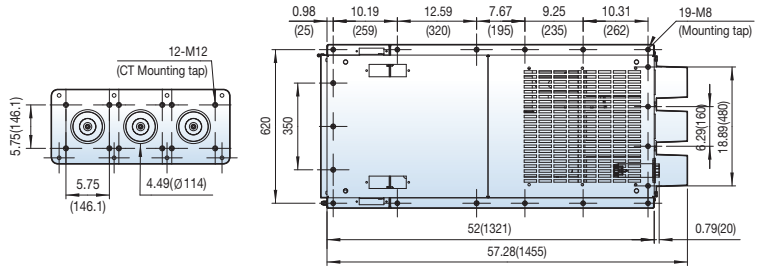

4.76/15kV, 25/31.5kA, 2000A

UVM type, Draw-out type

Cradle model

- UVCM-05H25C20
- UVCM-05H32C20
- UVCM-15H25C20
- UVCM-15H32C20

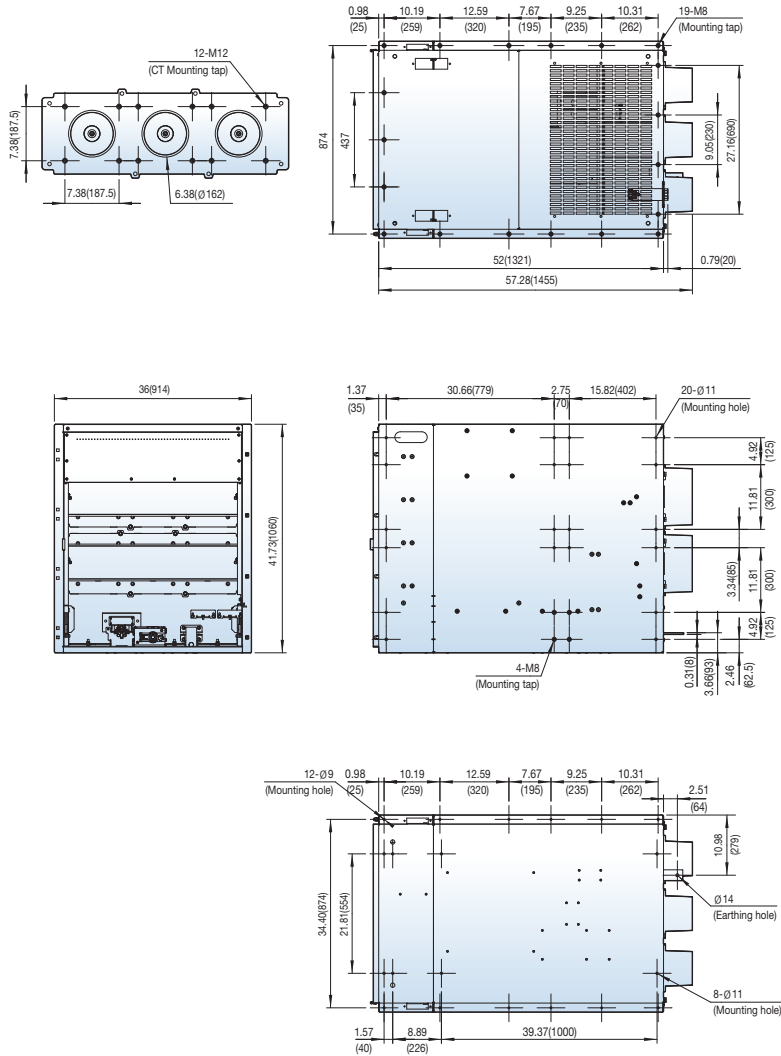

[Unit: in (mm)]

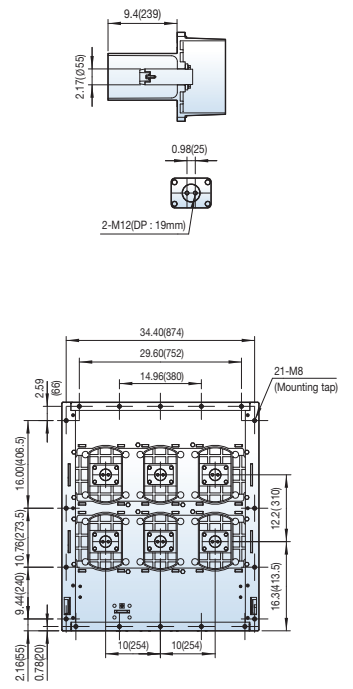

Dimensions

27kV, 25kA, 1200A

UVM type, Draw-out type

Cradle model

UVCM-27L25C12

[Unit: in(mm)]

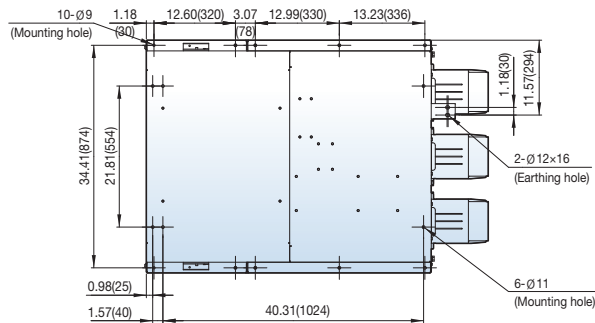
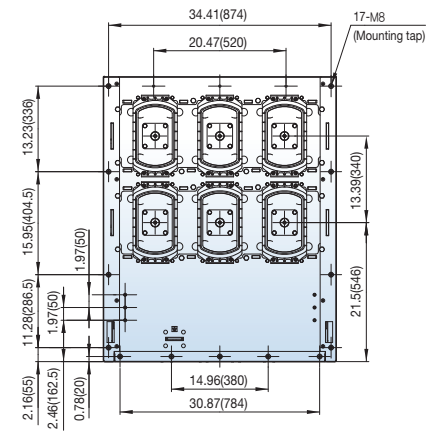
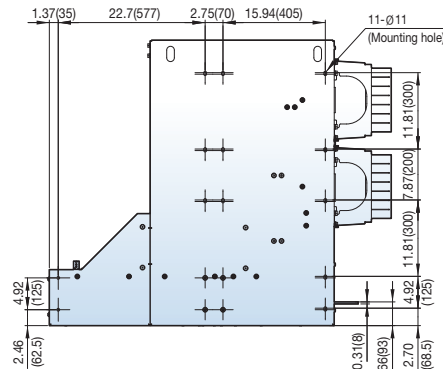
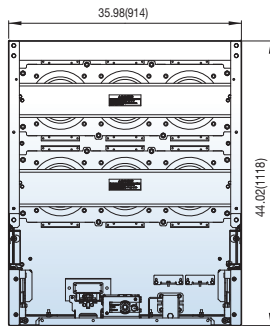
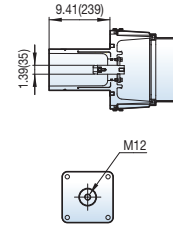
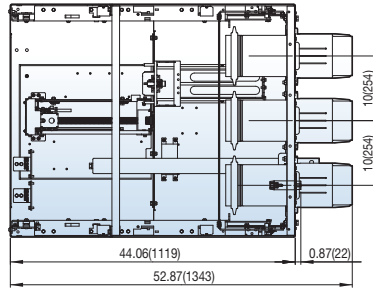
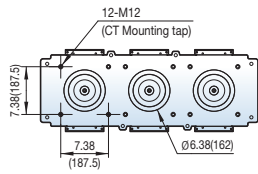

27kV, 25kA, 2000A

VVM type, Draw-out type

Cradle model

UVCM-27L25C20

[Unit: in(mm)]

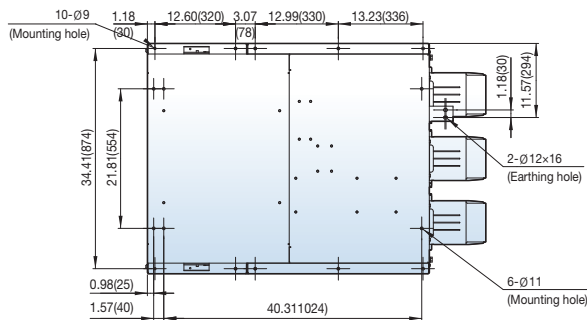
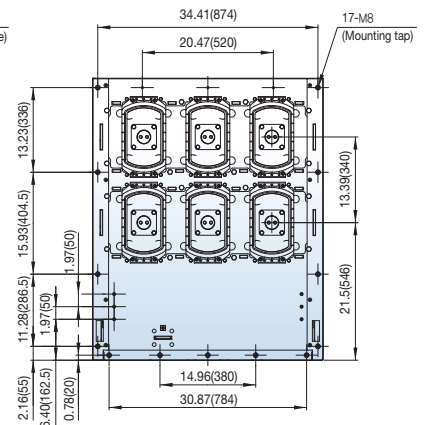
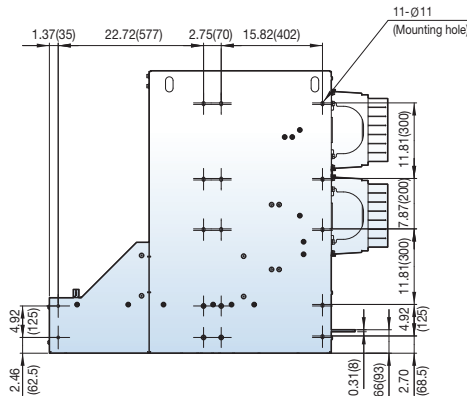
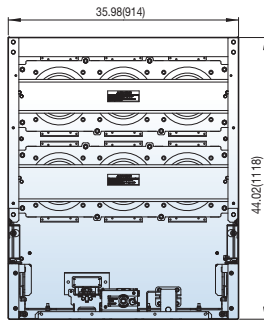
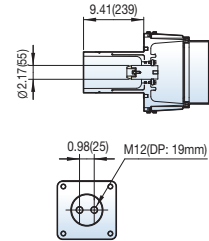
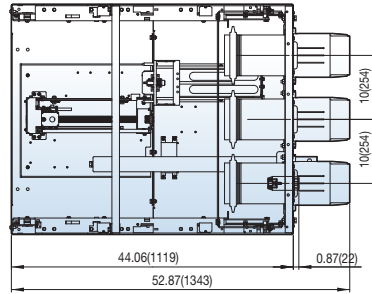
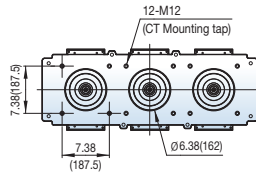

Dimensions

27kV, 25kA, 1200A

UVM type, Draw-out type

Cradle model

UVMC-27C25C12

[Unit: in(mm)]

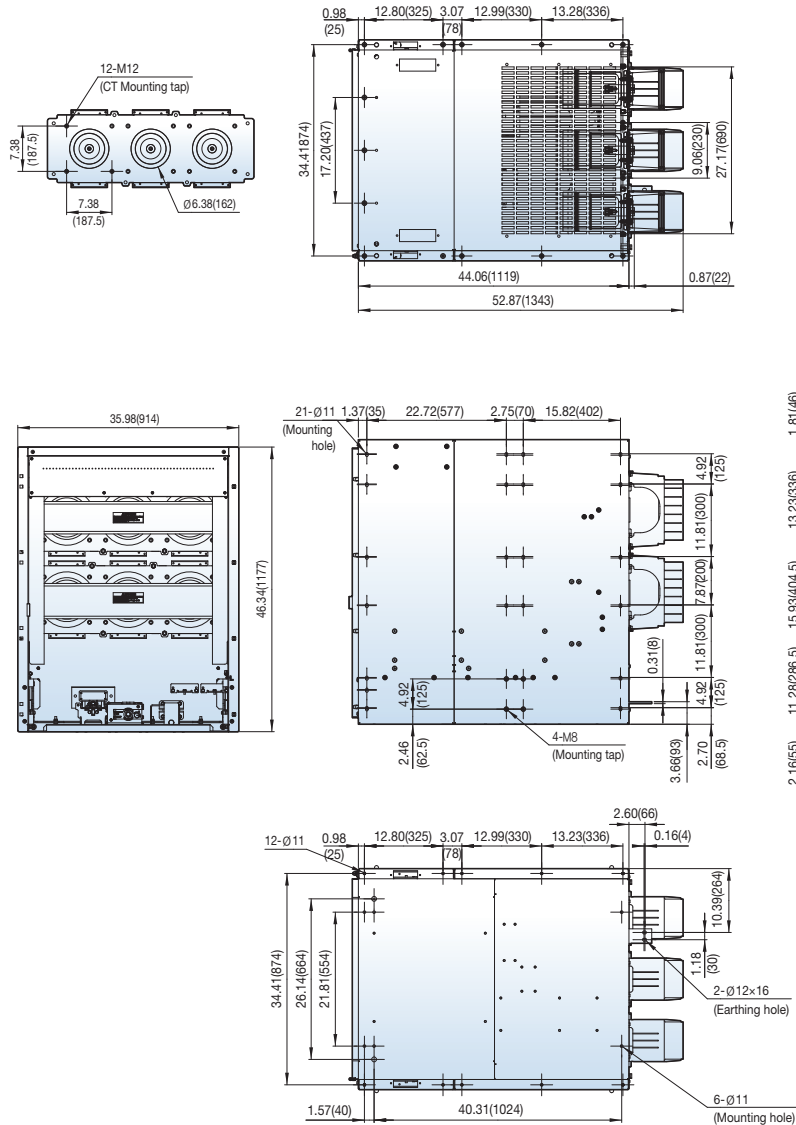

27kV, 25kA, 2000A

UVM type, Draw-out type

Cradle model

UVCM-27C25C20

[Unit: in(mm)]

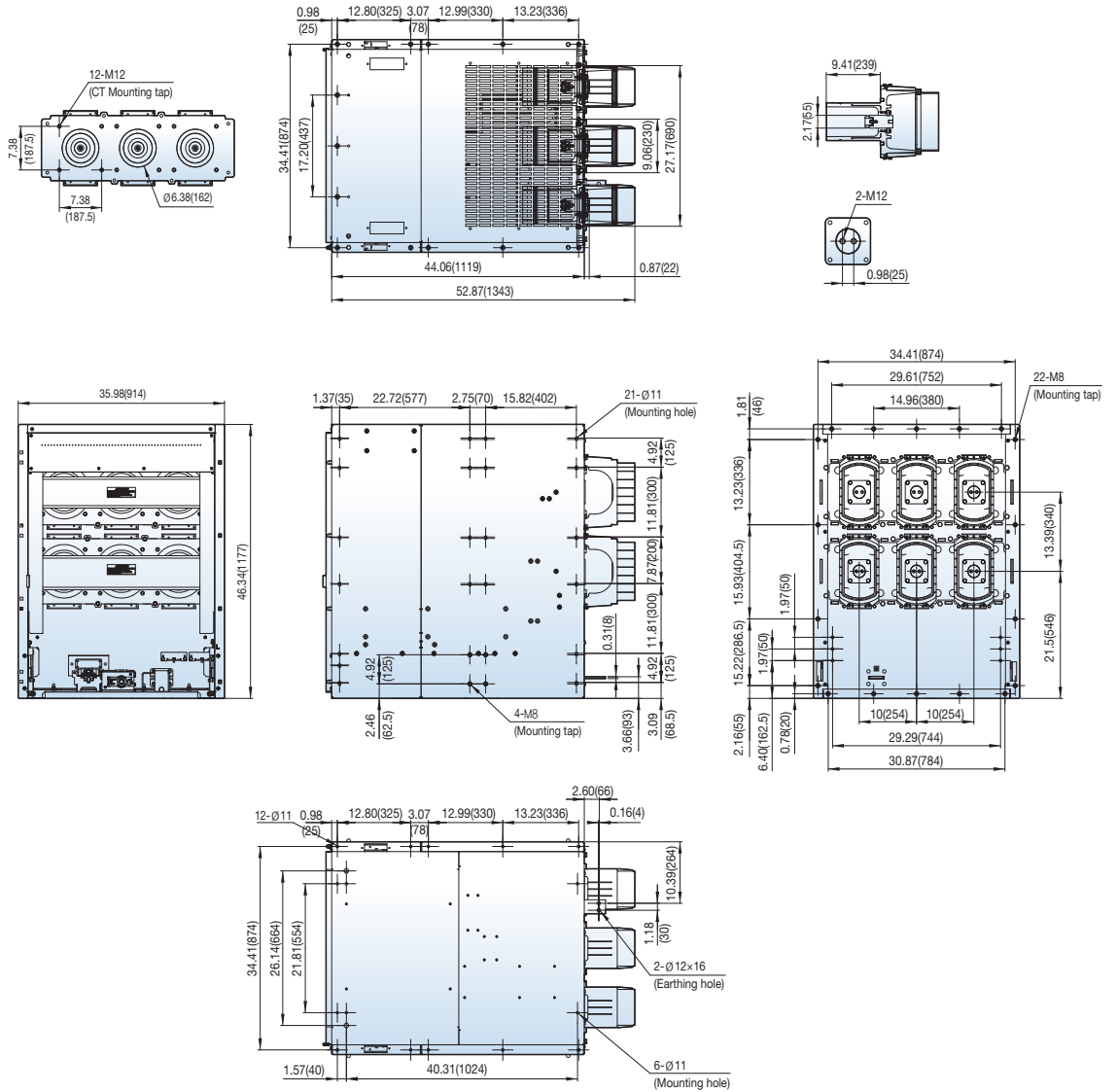

Dimensions

27kV, 25kA, 1200A

UVM type, Draw-out type

Cradle model

UVCM-27H25C12

[Unit: in(mm)]

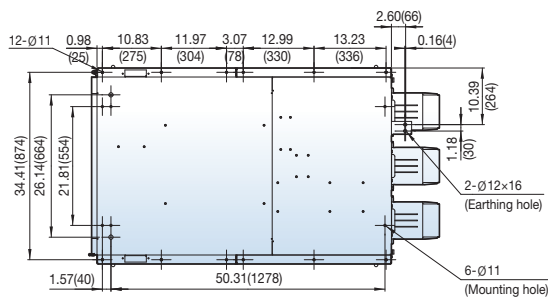
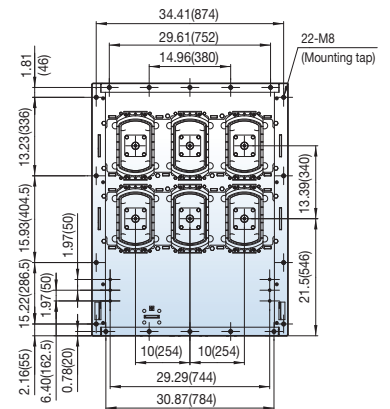
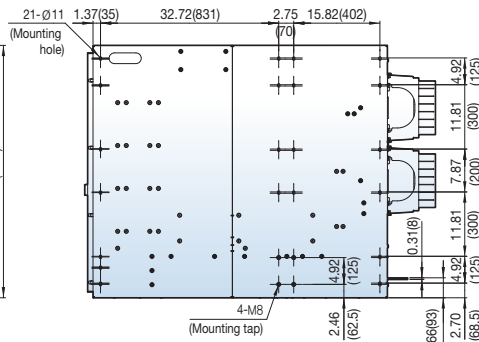
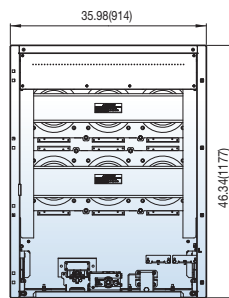
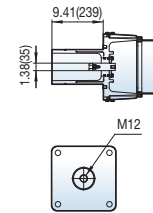
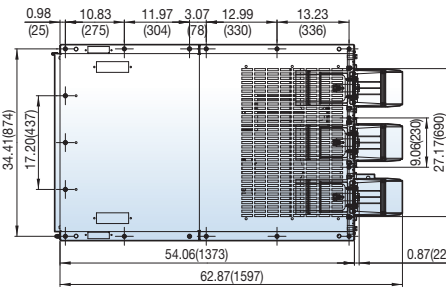
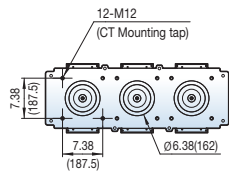

27kV, 25kA, 2000A

UVM type, Draw-out type

Cradle model
UVCM-27H25C20

[Unit: in(mm)]

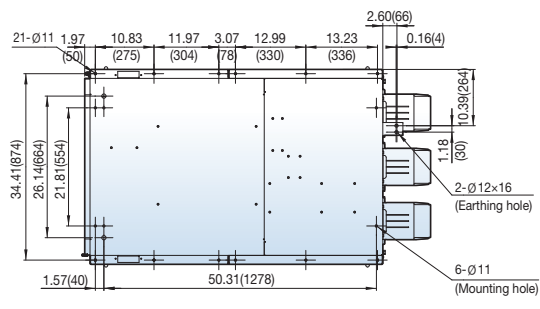
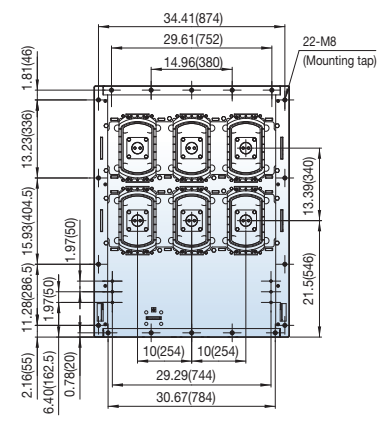
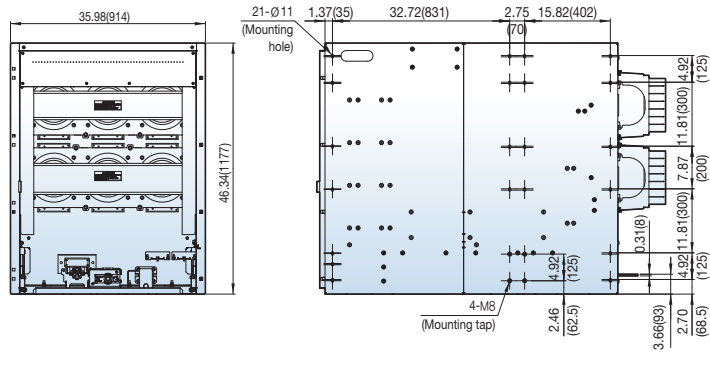
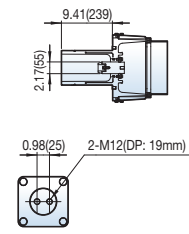
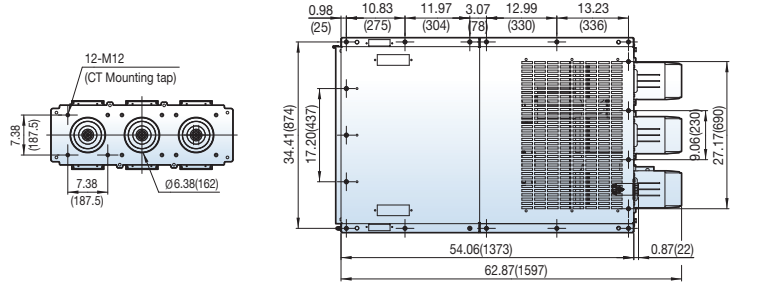

Memo

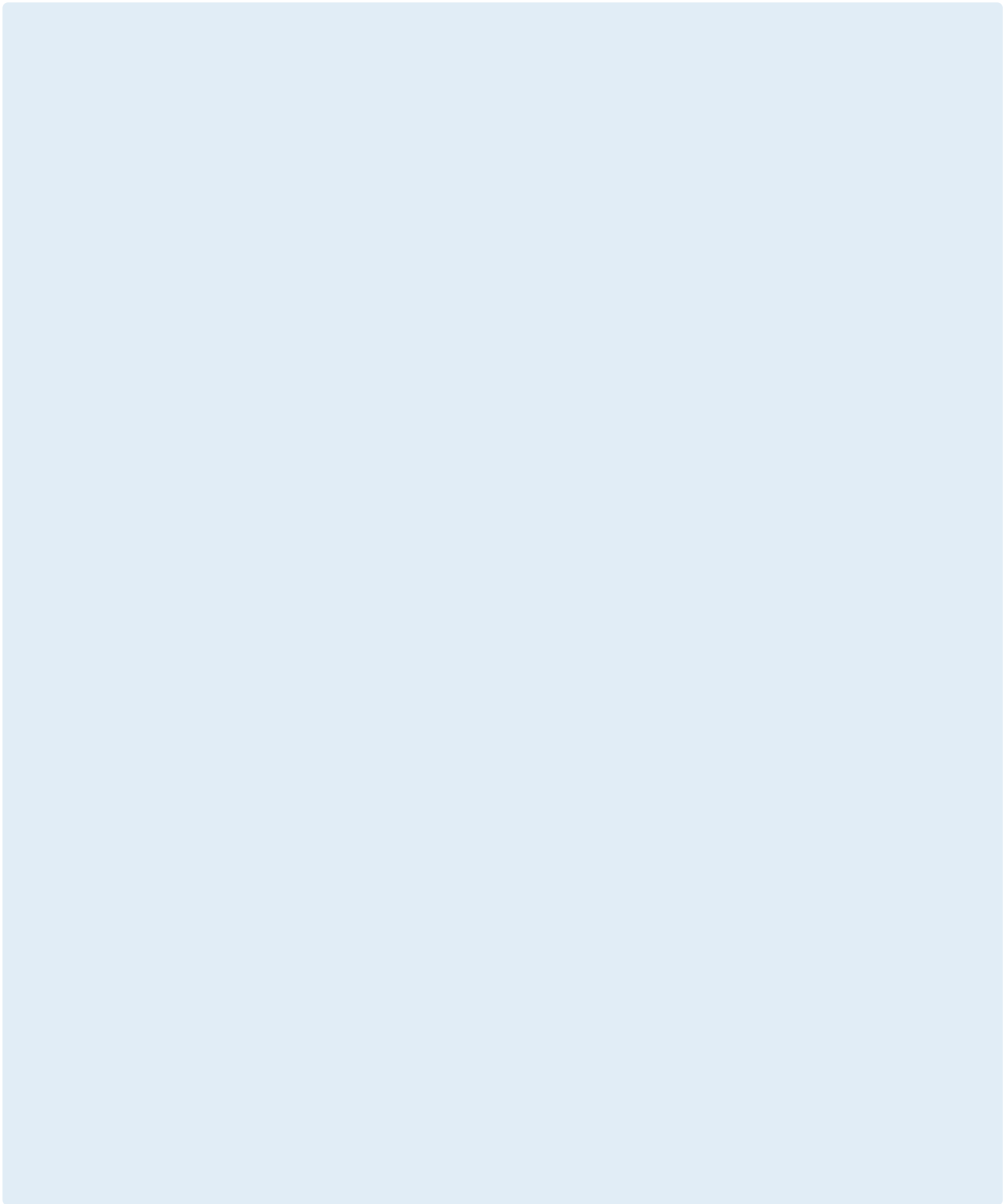

Susol UVH

Draw-out Type
(Draw in/out by using screw)



Contents

▪ Ratings and description	86
▪ Selection guide	88
▪ Order form	92
▪ Dimensions	94

Ratings and description

UVH type, Draw-out type



Circuit breaker type		UVH-05H															
Rated voltage	Ur (kV)	4.76															
Rated withstand voltage	Power frequency (1min)	Ud (kV) 19															
	Lightening impulse (1.2×50μs)	Up (kV) 60															
Rated short-circuit current	Isc (kA)	25				31.5				40				50			
Rated normal current	Ir (A)	3000	4000	3000	4000	1200	2000	3000	4000	1200	2000	3000	4000				
Rated frequency	fr (Hz)	60	60	60	60	60	60	60	60	60	60	60	60				
Rated short-circuit making current	Ip (kA) at 50 Hz	-															
	Ip (kA) at 60 Hz	65	65	81.9	81.9	104	104	104	104	130	130	130	130				
Rated short-time withstand current	Ik (kA)	25	25	31.5	31.5	40	40	40	40	50	50	50	50				
	3sec	●	●	●	●	●	●	●	●	●	●	●	●				
Operating sequence	O - 0.3s - CO - 15s - CO	●	●	●	●	●	●	●	●	●	●	●	●				



Circuit breaker type		UVH-15H															
Rated voltage	Ur (kV)	15															
Rated withstand voltage	Power frequency (1min)	Ud (kV) 36															
	Lightening impulse (1.2×50μs)	Up (kV) 95															
Rated short-circuit current	Isc (kA)	25				31.5				40				50			
Rated normal current	Ir (A)	3000	4000	3000	4000	1200	2000	3000	4000	1200	2000	3000	4000				
Rated frequency	fr (Hz)	60	60	60	60	60	60	60	60	60	60	60	60				
Rated short-circuit making current	Ip (kA) at 50 Hz	-															
	Ip (kA) at 60 Hz	65	65	81.9	81.9	104	104	104	104	130	130	130	130				
Rated short-time withstand current	Ik (kA)	25	25	31.5	31.5	40	40	40	40	50	50	50	50				
	3sec	●	●	●	●	●	●	●	●	●	●	●	●				
Operating sequence	O - 0.3s - CO - 15s - CO	●	●	●	●	●	●	●	●	●	●	●	●				

Technical data

Opening time	Less than 0.04 sec	
Rated breaking time	3 Cycle	
No-load closing time	Less than 0.06 sec	
Test class	Mechanical endurance	M2 (10,000)
	Electrical endurance	Reference standard (page 210)
	Capacitance	C2
Operating temperature	Low	- 40 °C
	High	40 °C

UVH type, Draw-out type



Circuit breaker type		UVH-27H									
Rated voltage	Ur (kV)	27									
Rated withstand voltage	Power frequency (1min)	Ud (kV)	60								
	Lightening impulse (1.2×50μs)	Up (kV)	125								
Rated short-circuit current	Isc (kA)	25	31.5				40				
Rated normal current	Ir (A)	2500	2750	1200	2000	2500	2750	1200	2000	2500	2750
Rated frequency	fr (Hz)	60	60	60	60	60	60	60	60	60	60
Rated short-circuit making current	I _p (kA) at 50 Hz	-	-	-	-	-	-	-	-	-	-
	I _p (kA) at 60 Hz	65	65	81.9	81.9	81.9	81.9	104	104	104	104
Rated short-time withstand current	I _k (kA)	25	25	31.5	31.5	31.5	31.5	40	40	40	40
	3sec	●	●	●	●	●	●	●	●	●	●
Operating sequence	O - 0.3s - CO - 15s - CO	●	●	●	●	●	●	●	●	●	●



Circuit breaker type		UVH-38H						
Rated voltage	Ur (kV)	38						
Rated withstand voltage	Power frequency (1min)	Ud (kV)	80					
	Lightening impulse (1.2×50μs)	Up (kV)	170					
Rated short-circuit current	Isc (kA)	31.5	40					
Rated normal current	Ir (A)	1200	2000	3000	1200	2000	3000	
Rated frequency	fr (Hz)	60	60	60	60	60	60	
Rated short-circuit making current	I _p (kA) at 50 Hz	-	-	-	-	-	-	
	I _p (kA) at 60 Hz	81.9	81.9	81.9	104	104	104	
Rated short-time withstand current	I _k (kA)	31.5	31.5	31.5	40	40	40	
	3sec	●	●	●	●	●	●	
Operating sequence	O - 0.3s - CO - 15s - CO	●	●	●	●	●	●	

Technical data

Opening time	Less than 0.04 sec	
Rated breaking time	3 Cycle	
No-load closing time	Less than 0.06 sec	
Test class	Mechanical endurance	M2 (10,000)
	Electrical endurance	Reference standard (page 210)
	Capacitance	C2
Operating temperature	Low	-40 °C
	High	40 °C

Selection guide

Description for circuit breaker type

UVH type, Draw-out type

Model	Rated voltage (kV)	Type	Interrupting current (kA)	Phase distance	Rated current (A)
UVH Susol VCB	05 4.76 15 15	H Draw-out Type (For UVM, UVH MCSG)	40 40 50 50 25 25 32 31.5 40 40 50 50	A 7in(178mm) C 10in(254mm) C 10in(254mm) L 12.59in(320mm)	12 1200 20 2000 30 3000 40 4000
	27 27	H Draw-out Type (For UVM, UVH MCSG)	40 31.5 40 40 25 25 32 31.5 40 40	C 10in(254mm) C 10in(254mm)	12 1200 20 2000 25 2500 28 2750
	38 38	H Draw-out Type (For UVM, UVH MCSG)	40 31.5 40 40	E 11.8"(300mm)	12 1200 20 2000 30 3000

Selection table of circuit breaker type

Select withdrawal VCB/Cradle with same horizontal line.

Ur [kV]	Isc [kA]	Ir [A]			Circuit breaker Model	Weight [lb]	Outline dimension H×W×D [in]	Dimension page
		p = 7"	p = 10"	p = 12.59"				
4.76	25			3000	UVH-05H25C30	573.2	31.7×31.9×28.8	97
				4000	UVH-05H25L40	970	39.4×40.9×28.6	97
	31.5			3000	UVH-05H32C30	573.2	31.7×31.9×28.8	97
				4000	UVH-05H32L40	970	39.4×40.9×28.6	97
	40	1200 2000		1200	UVH-05H40A12	429.9	31.7×21.9×28.8	94
					UVH-05H40A20	463	31.7×21.9×28.8	96
					UVH-05H40C12	463	31.7×31.9×28.8	94
					UVH-05H40C20	496	31.7×31.9×28.8	96
					UVH-05H40C30	573.2	31.7×31.9×28.8	97
					UVH-05H40L40	970	39.4×40.9×28.6	97
	50	1200 2000		1200	UVH-05H50A12	463	31.7×21.9×28.8	95
					UVH-05H50A20	463	31.7×21.9×28.8	96
					UVH-05H50C12	496	31.7×31.9×28.8	95
					UVH-05H50C20	496	31.7×31.9×28.8	96
					UVH-05H50C30	573.2	31.7×31.9×28.8	97
UVH-05H50L40					970	39.4×40.9×28.6	97	
15	25			3000	UVH-15H25C30	573.2	31.7×31.9×28.8	97
				4000	UVH-15H25L40	970	39.4×40.9×28.6	97
	31.5			3000	UVH-15H32C30	573.2	31.7×31.9×28.8	97
				4000	UVH-15H32L40	970	39.4×40.9×28.6	97
	40	1200 2000		1200	UVH-15H40A12	429.9	31.7×21.9×28.8	94
					UVH-15H40A20	463	31.7×21.9×28.8	96
					UVH-15H40C12	463	31.7×31.9×28.8	94
					UVH-15H40C20	496	31.7×31.9×28.8	96
					UVH-15H40C30	573.2	31.7×31.9×28.8	97
					UVH-15H40L40	970	39.4×40.9×28.6	97
	50	1200 2000		1200	UVH-15H50A12	463	31.7×21.9×28.8	95
					UVH-15H50A20	463	31.7×21.9×28.8	96
					UVH-15H50C12	496	31.7×31.9×28.8	95
					UVH-15H50C20	496	31.7×31.9×28.8	96
					UVH-15H50C30	573.2	31.7×31.9×28.8	97
UVH-15H50L40					970	39.4×40.9×28.6	97	

Ur [kV]	Isc [kA]	Ir [A]		Circuit breaker Model	Weight [lb]	Outline dimension H×W×D [in]	Dimension page
		p = 10"	p = 11.8"				
27	25	2500		UVH-27H25C25	705.5	36.6×31.9×34.8	99
		2750		UVH-27H25C28	705.5	36.6×31.9×34.8	99
	31.5	1200		UVH-27H32C12	606.3	36.6×31.9×34.8	98
		2000		UVH-27H32C20	606.3	36.6×31.9×34.8	98
		2500		UVH-27H32C25	705.5	36.6×31.9×34.8	99
		2750		UVH-27H32C28	705.5	36.6×31.9×34.8	99
	40	1200		UVH-27H40C12	606.3	36.6×31.9×34.8	98
		2000		UVH-27H40C20	606.3	36.6×31.9×34.8	98
		2500		UVH-27H40C25	705.5	36.6×31.9×34.8	99
		2750		UVH-27H40C28	705.5	36.6×31.9×34.8	99
38	31.5		1200	UVH-38H32E12	881.8	43.3×37.9×39.4	100
			2000	UVH-38H32E20	881.8	43.3×37.9×39.4	100
			3000	UVH-38H32E30	1038.8	43.3×37.9×39.4	100
	40		1200	UVH-38H40E12	881.8	43.3×37.9×39.4	100
			2000	UVH-38H40E20	881.8	43.3×37.9×39.4	100
			3000	UVH-38H40E30	1038.8	43.3×37.9×39.4	100

Selection guide

Description for Cradle



H type

UVCH	
Model	
UVCH	Susol UL VCB Cradle (UVCH)

15	
Rated voltage (kV)	
5	4.76
15	15

H	
Type	
L	MCSG Cradle type
C	Compact type Draw-out (for MCSG)
H	H type Draw-out (for MCSG)

40	
Interrupting current (kA)	
25	25
32	31.5

A	
Phase distance	
A	7in(178mm)
C	10in(254mm)

12	
Rated current (A)	
12	1200
20	2000

25	25
32	31.5
40	40
50	50

C	10in(254mm)
---	-------------

30	3000
----	------

L	MCSG Cradle type
H	H type Draw-out (for MCSG)

25	25
32	31.5
40	40
50	50

L	12.59in(320mm)
---	----------------

40	4000
----	------

27	
Rated voltage (kV)	
27	27

H	
Type	
L	MCSG Cradle type
C	Compact type Draw-out (for MCSG)
H	H type Draw-out (for MCSG)

40	
Interrupting current (kA)	
32	31.5
40	40
25	25
32	31.5
40	40

C	
Phase distance	
C	10in(254mm)

12	
Rated current (A)	
12	1200
20	2000

C	10in(254mm)
---	-------------

25	2500
40	2750

38	
Rated voltage (kV)	
38	38

H	
Type	
H	H type Draw-out (for MCSG)
D	D type Draw-out (for Direct Roll In)

40	
Interrupting current (kA)	
32	31.5
40	40

E	
Phase distance	
E	11.8in(300mm)

12	
Rated current (A)	
12	1200
20	2000
30	3000

Note) When selecting D type, ensure that the VCB main body AS option is included.

Selection table of cradle

UVH type, L type

Ur [kV]	Isc [kA]	Ir [A]			Arc resistance	Cradle model □ = [L, C*, H]	Outline dimension H×W×D [in]			Dimension by type page			
		p = 7"	p = 10"	p = 12.59"			L - type	C - type	H - type	L	C	H	
4.76	25	3000			-	UVCH-05□25C30	40×36×47.3	41.7×36×56.9	41.7×36×57.3	119	120	121	
		4000			-	UVCH-05L25L40	49.8×47.2×47.6	-	-	122	-	-	
	4000			-	UVCH-05H25L40	-	-	49.8×47.2×47.6	-	-	123		
	31.5	3000			-	UVCH-05□32C30	40×36×47.3	41.7×36×56.9	41.7×36×57.3	119	120	121	
		4000			-	UVCH-05L32L40	49.8×47.2×47.6	-	-	122	-	-	
	4000			-	UVCH-05H32L40	-	-	49.8×47.2×47.6	-	-	123		
	40	1200			-	UVCH-05□40A12	40×26×47.3	41.7×26×56.9	41.7×26×57.3	101	103	105	
		2000			-	UVCH-05□40A20	40×26×47.3	41.7×26×56.9	41.7×26×57.3	113	115	117	
		1200			-	UVCH-05□40C12	40×36×47.3	41.7×36×56.9	41.7×36×57.3	102	104	106	
		2000			-	UVCH-05□40C20	40×36×47.3	41.7×36×56.9	41.7×36×57.3	114	116	118	
		3000			-	UVCH-05□40C30	40×36×47.3	41.7×36×56.9	41.7×36×57.3	119	120	121	
		4000			-	UVCH-05L40L40	49.8×47.2×47.6	-	-	122	-	-	
		4000			-	UVCH-05H40L40	-	-	49.8×47.2×47.6	-	-	123	
		1200			-	UVCH-05□50A12	40×26×47.3	41.7×26×56.9	41.7×26×57.3	107	109	111	
		2000			-	UVCH-05□50A20	40×26×47.3	41.7×26×56.9	41.7×26×57.3	113	115	117	
		1200			-	UVCH-05□50C12	40×36×47.3	41.7×36×56.9	41.7×36×57.3	108	110	112	
	15	25	3000			-	UVCH-15□25C30	40×36×47.3	41.7×36×56.9	41.7×36×57.3	119	120	121
			4000			-	UVCH-15L25L40	49.8×47.2×47.6	-	-	122	-	-
		4000			-	UVCH-15H25L40	-	-	49.8×47.2×47.6	-	-	123	
		31.5	3000			-	UVCH-15□32C30	40×36×47.3	41.7×36×56.9	41.7×36×57.3	119	120	121
4000			-	UVCH-15L32L40	49.8×47.2×47.6	-	-	122	-	-			
4000			-	UVCH-15H32L40	-	-	49.8×47.2×47.6	-	-	123			
40		1200			-	UVCH-15□40A12	40×26×47.3	41.7×26×56.9	41.7×26×57.3	101	103	105	
		2000			-	UVCH-15□40A20	40×26×47.3	41.7×26×56.9	41.7×26×57.3	113	115	117	
		1200			-	UVCH-15□40C12	40×36×47.3	41.7×36×56.9	41.7×36×57.3	102	104	106	
		2000			-	UVCH-15□40C20	40×36×47.3	41.7×36×56.9	41.7×36×57.3	114	116	118	
		3000			-	UVCH-15□40C30	40×36×47.3	41.7×36×56.9	41.7×36×57.3	119	120	121	
		4000			-	UVCH-15L40L40	49.8×47.2×47.6	-	-	122	-	-	
	4000			-	UVCH-15H40L40	-	-	49.8×47.2×47.6	-	-	123		
	1200			-	UVCH-15□50A12	40×26×47.3	41.7×26×56.9	41.7×26×57.3	107	103	111		
	2000			-	UVCH-15□50A20	40×26×47.3	41.7×26×56.9	41.7×26×57.3	113	115	117		
	1200			-	UVCH-15□50C12	40×36×47.3	41.7×36×56.9	41.7×36×57.3	108	110	112		
50	2000			-	UVCH-15□50C20	40×36×47.3	41.7×36×56.9	41.7×36×57.3	114	116	118		
	3000			-	UVCH-15□50C30	40×36×47.3	41.7×36×56.9	41.7×36×57.3	119	120	121		
	4000			-	UVCH-15L50L40	49.8×47.2×47.6	-	-	122	-	-		
	4000			-	UVCH-15H50L40	-	-	49.8×47.2×47.6	-	-	123		

Ur [kV]	Isc [kA]	Ir [A]		Arc resistance	Cradle model □ = [L, C*, H] △ = [H, D]	Outline dimension H×W×D [in]				Dimension by type page			
		p = 10"	p = 11.8"			L - type	C - type	H - type	D - type	L	C	H	D
27	25	2500	-	UVCH-27□25C25	44.1×36×56.7	46.3×36×66.3	46.3×36×66.7	-	126	130	134	-	
		2750	-	UVCH-27□25C28	44.1×36×56.7	46.3×36×66.3	46.3×36×66.7	-	127	131	135	-	
	31.5	1200		-	UVCH-27□32C12	44.1×36×56.7	46.3×36×66.3	46.3×36×66.7	-	124	128	132	-
		2000		-	UVCH-27□32C20	44.1×36×56.7	46.3×36×66.3	46.3×36×66.7	-	125	129	133	-
		2500		-	UVCH-27□32C25	44.1×36×56.7	46.3×36×66.3	46.3×36×66.7	-	126	130	134	-
		2750		-	UVCH-27□32C28	44.1×36×56.7	46.3×36×66.3	46.3×36×66.7	-	127	131	135	-
	40	1200		-	UVCH-27□40C12	44.1×36×56.7	46.3×36×66.3	46.3×36×66.7	-	124	128	132	-
		2000		-	UVCH-27□40C20	44.1×36×56.7	46.3×36×66.3	46.3×36×66.7	-	125	129	133	-
		2500		-	UVCH-27□40C25	44.1×36×56.7	46.3×36×66.3	46.3×36×66.7	-	126	130	134	-
		2750		-	UVCH-27□40C28	44.1×36×56.7	46.3×36×66.3	46.3×36×66.7	-	127	131	135	-
	38	31.5	1200	-	UVCH-38△32E12	-	-	71.9×42×72.9	60.6×42×60.6	-	-	136	138
			2000	-	UVCH-38△32E20	-	-	71.9×42×72.9	60.6×42×60.6	-	-	136	138
3000			-	UVCH-38△32E30	-	-	71.9×42×72.9	60.6×42×60.6	-	-	137	139	
40		1200	-	UVCH-38△40E12	-	-	71.9×42×72.9	60.6×42×60.6	-	-	136	138	
		2000	-	UVCH-38△40E20	-	-	71.9×42×72.9	60.6×42×60.6	-	-	136	138	
		3000	-	UVCH-38△40E30	-	-	71.9×42×72.9	60.6×42×60.6	-	-	137	139	

Order form

Full description for circuit breaker

UVH type, Draw-out type

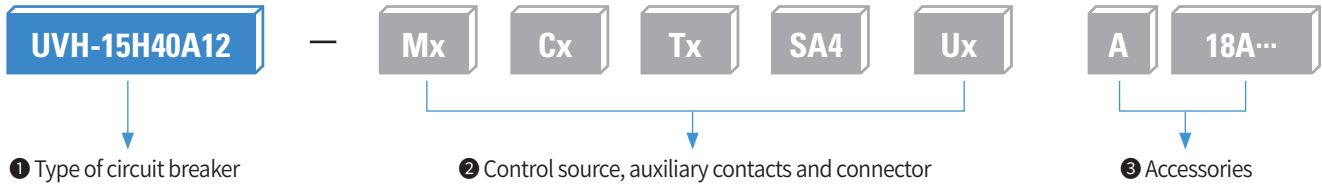

① Type of circuit breaker
(select from the previous page)

② Control source, auxiliary contacts and connector

③ Accessories

※ In case of selecting ③ Accessories, only type Symbol 'A' once. (ex. A18A)

Order form for circuit breaker

Please select only one item per line. (* Required selection)

UVH, VCB, Draw-out type

(○ no extra charge □ extra charge)

① Type of VCB from selection table*		Quantity	ea
② Accessories			
Motor* (Mx)			page 164
<input type="radio"/> M2	<input type="radio"/> M3	<input type="radio"/> M4	<input type="radio"/> M5
DC 200V ~ 250V	DC 125V	DC 24V ~ 30V	DC 48V ~ 60V
<input type="radio"/> M6	<input type="radio"/> M7	<input type="radio"/> M8	
AC 48V	AC 100V ~ 130V	AC 200V ~ 250V	
Closing coil* (Cx)			page 165
<input type="radio"/> C2	<input type="radio"/> C3	<input type="radio"/> C4	<input type="radio"/> C5
DC 200V ~ 250V	DC 125V	DC 24V ~ 30V	DC 48V ~ 60V
<input type="radio"/> C6	<input type="radio"/> C7	<input type="radio"/> C8	
AC 48V	AC 100V ~ 130V	AC 200V ~ 250V	
Shunt trip coil* (Tx)			page 166
<input type="radio"/> T2	<input type="radio"/> T3	<input type="radio"/> T4	<input type="radio"/> T5
DC 200V ~ 250V	DC 125V	DC 24V ~ 30V	DC 48V ~ 60V
<input type="radio"/> T6	<input type="radio"/> T7	<input type="radio"/> T8	
AC 48V	AC 100V ~ 130V	AC 200V ~ 250V	
Auxiliary contacts & Connector type*			page 169
<input type="radio"/> SC2 (4a4b, Auto-con type)		<input type="radio"/> SC4 (10a10b, Auto-con type)	
Under voltage release (Ux)			page 170
<input type="radio"/> U0	<input type="checkbox"/> U2	<input type="checkbox"/> U3	<input type="checkbox"/> U4
Without UVT	DC 200V ~ 250V	DC 125V	DC 24V ~ 30V
<input type="checkbox"/> U5	<input type="checkbox"/> U6	<input type="checkbox"/> U7	<input type="checkbox"/> U8
DC 48V ~ 60V	AC 48V	AC 100V ~ 130V	AC 200V ~ 250V
※ Even without UVT, U0 must be selected to make VCB ordering code and description			
Secondary shunt trip coil			page 167
<input type="checkbox"/> A1 (Secondary shunt trip coil)		<input type="checkbox"/> A2 (Secondary shunt trip coil monitoring contact)	
※ In case of selecting A2, maximum auxiliary contacts are 10a9b			
Latch checking s/w			page 171
<input type="checkbox"/> A6		※ In case of selecting UVT, latch checking s/w is applied by default, so cannot select it additionally.	
Keylock			page 172
<input type="checkbox"/> A7 (Keylock)		<input type="checkbox"/> AM (KirkKey, CAMLOCK type)	
Button padlock			page 173
<input type="checkbox"/> A8 (Button padlock)			
MOC operator*			page 177
<input type="checkbox"/> AE			
Auxiliary wheels (Direct Roll-in)			page 177
<input type="checkbox"/> AS		※ For UVCH-38D type, the AS option is mandatory.	

Combination table

U0	1	
U1~8		1
A1 & A2	1	
A6		1

Auxiliary contact

Symbol	10a10b
Standard	10 NO, 10 NC
with A1	10 NO, 10 NC
with A2	10 NO, 9 NC

Accessories (Sold separately)

CTU (Coil test unit)		page 179
<input type="checkbox"/> 73873171221 CTU (Coil test unit)		
CTD (Condenser trip device)		page 180
<input type="checkbox"/> 76113143001 CTD (Condenser trip device) DC 125V		
<input type="checkbox"/> 76113143002 CTD (Condenser trip device) DC 250V		
UDC (UVT delay controller)		page 181
<input type="checkbox"/> 52773171282 UDC (UVT delay controller) AC/DC 100~130V		
<input type="checkbox"/> 52773171283 UDC (UVT delay controller) AC/DC 200~250V		
<input type="checkbox"/> 52773171281 UDC (UVT delay controller) DC 48~60V and AC 48V		

Full description for cradle

UVH type, Draw-out type

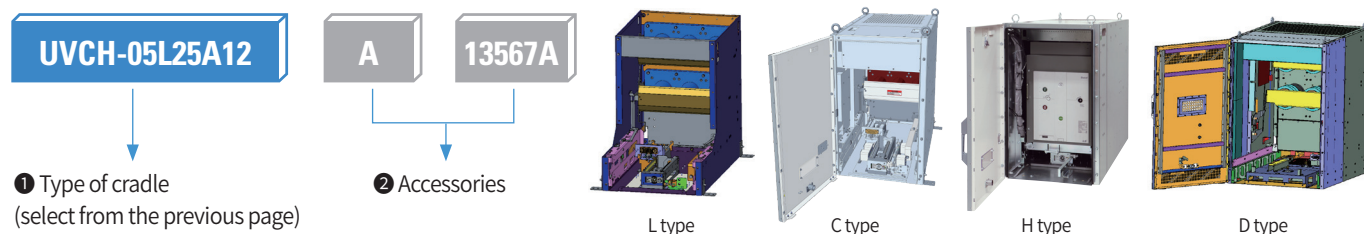

Order form for cradle

Please select only one item per line. (* Required selection)

UVH, VCB, Draw-out type

(○ no extra charge □ extra charge)

① Type of VCB from selection table*	Quantity	ea
② Accessories		
Lead wire*		page 174
<input type="checkbox"/> A1 (4a4b)	<input type="checkbox"/> A2 (10a10b)	
Standard set (Shutter padlock, TOC, MOC)*		
<input type="checkbox"/> A3 (6a6b(MOC,TOC)) (UVCH-05/15/27H ONLY)	<input type="checkbox"/> A4 (12a12b(MOC,TOC)) (UVCH-05/15H ONLY)	page 182 ~ 183
<input type="checkbox"/> A3 (4a4b(MOC,TOC)) (UVCH-38H, D type ONLY)		
※ In case of selecting Remote Racking System, Maximum contacts of MOC are 4a4b. ※ In case of selecting Remote Racking System, Maximum contacts of MOC are 10a10b.		
Padlock (UVCH-05/15/27C, H Type cradle ONLY)		
<input type="checkbox"/> A5		page 183
Door (Only for C, H, D type cradle)		
<input type="checkbox"/> A6	※ If door is selected for UVCH-38H,D, option A8 must be selected.	
		page 184
Door interlock (Only for C, H, D type cradle)		
<input type="checkbox"/> A7		page 185
Door emergency push button (UVCH-38H, D type ONLY)		
<input type="checkbox"/> A8 (Button padlock)		page 185
Kirk key interlock (UVCH-05/15/27C, H ONLY)		
<input type="checkbox"/> A9		page 187
※ In case of selecting Remote Racking System, A9 must be selected to make cradle ordering code and description. The Kirk-key is not provided separately.		
Remote racking system (UVCH-05/15/27C, H Type cradle ONLY)		
<input type="checkbox"/> AA (AC120V, Without OPEN, CLOSE Function)	<input type="checkbox"/> AB (AC240V, Without OPEN, CLOSE Function)	page 187
<input type="checkbox"/> AC (DC125V, Without OPEN, CLOSE Function)	<input type="checkbox"/> AD (DC250V, Without OPEN, CLOSE Function)	
<input type="checkbox"/> AE (AC120V, With OPEN, CLOSE Function)	<input type="checkbox"/> AF (AC240V, With OPEN, CLOSE Function)	
<input type="checkbox"/> AG (DC125V, With OPEN, CLOSE Function)	<input type="checkbox"/> AH (DC250V, With OPEN, CLOSE Function)	
Insulation ring for 170kV Lightning Impulse (UVCH-38 ONLY)		
<input type="checkbox"/> AS		page 188

Accessories (Sold separately)

Racking In/Out handle	<input type="checkbox"/> 55223181007 (Normal type of L-Cradle) <input type="checkbox"/> 55213163003 (UVCH-38kV H, D type Cradle Only) <input type="checkbox"/> 55223181001 (UVCH H, D-type Cradle) <input type="checkbox"/> 55223181003 (UVCH C-type Cradle Only)	<input type="checkbox"/> 55223181002 (UVCH H-type Cradle for MCRS) <input type="checkbox"/> 55223181004 (UVCH C-type Cradle Only for MCRS)	page 189 ~ 191
Charge handle	<input type="checkbox"/> 55213143046		page 189
Extension rail	<input type="checkbox"/> 59023181003 (L-Cradle / C-Cradle / H-Cradle for UVCH-05/15H) <input type="checkbox"/> 59023181009 (H-Cradle for UVCH-27H)		page 192 ~ 193

Dimensions

4.76/15kV, 40kA, 1200A

UVH type, Draw-out type

[Unit: in(mm)]

Circuit breaker model

UVH-05H40A12
UVH-15H40A12

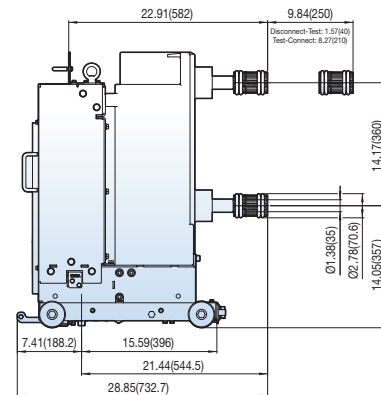
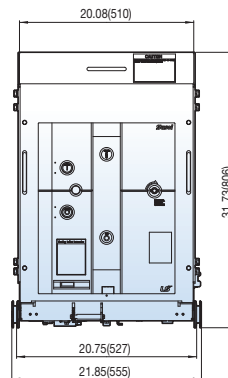
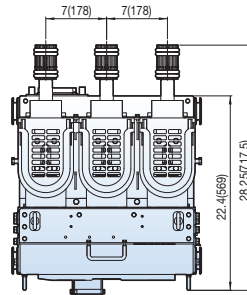

Circuit breaker model

UVH-05H40C12
UVH-15H40C12

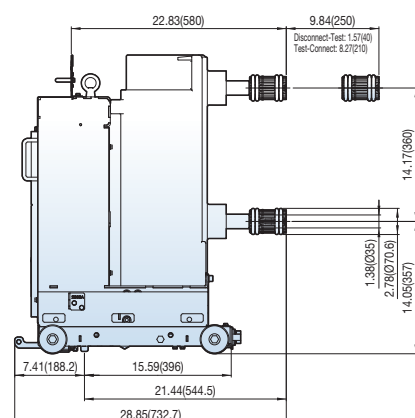
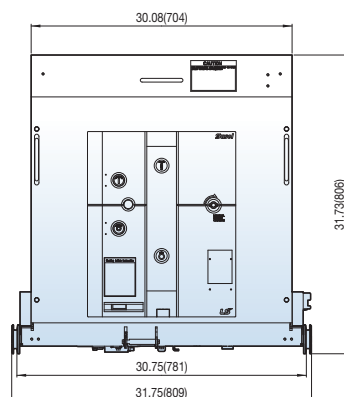
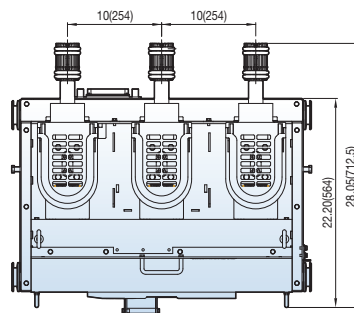

4.76/15kV, 50kA, 1200A

UVH type, Draw-out type

Circuit breaker model

UVH-05H50A12
UVH-15H50A12

[Unit: in(mm)]

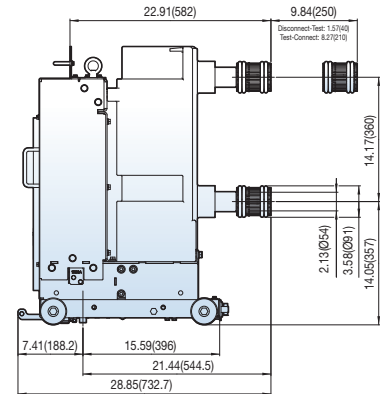
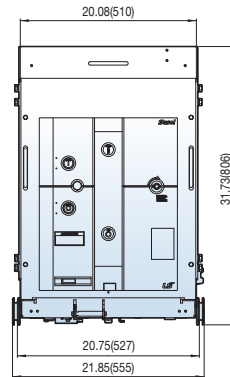
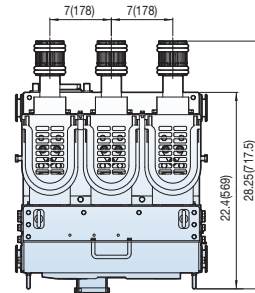

Circuit breaker model

UVH-05H50C12
UVH-15H50C12

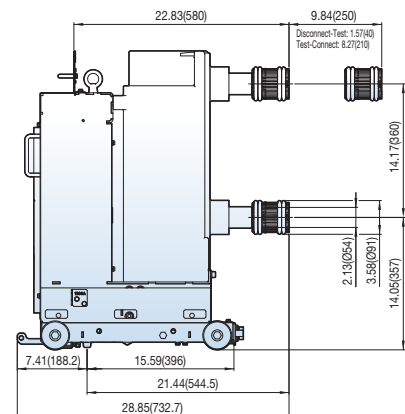
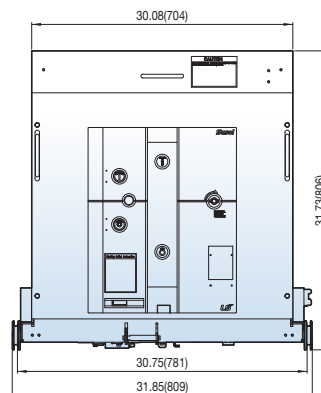
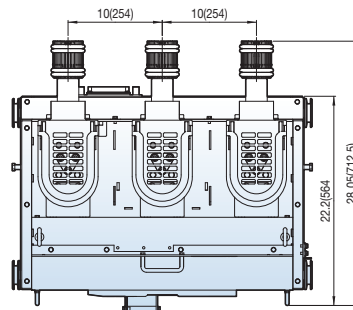

Dimensions

4.76/15kV, 40/50kA, 2000A

UVH type, Draw-out type

[Unit: in(mm)]

Circuit breaker model

- UVH-05H40A20
- UVH-05H50A20
- UVH-15H40A20
- UVH-15H50A20

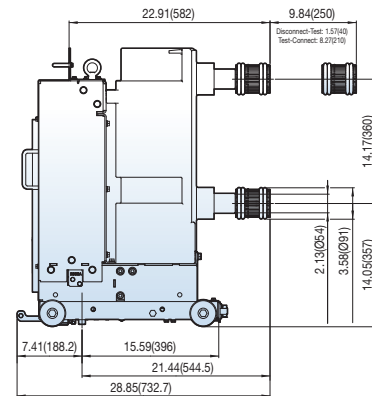
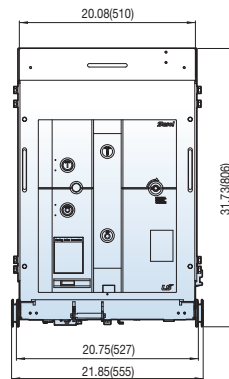
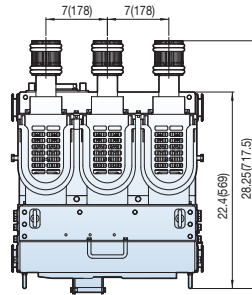

Circuit breaker model

- UVH-05H40C20
- UVH-05H50C20
- UVH-15H40C20
- UVH-15H50C20

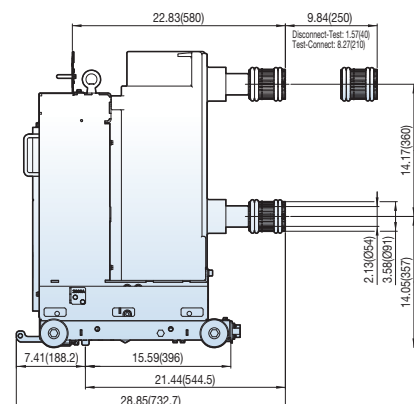
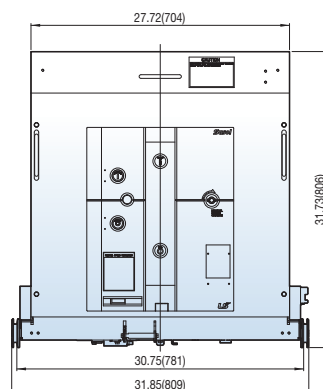
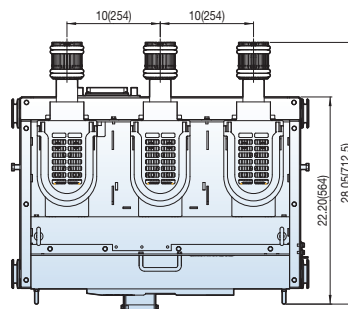

4.76/15kV, 25/31.5/40/50kA, 3000A

UVH type, Draw-out type

Circuit breaker model

- UVH-05H25C30
- UVH-05H32C30
- UVH-05H40C30
- UVH-05H50C30
- UVH-15H25C30
- UVH-15H32C30
- UVH-15H40C30
- UVH-15H50C30

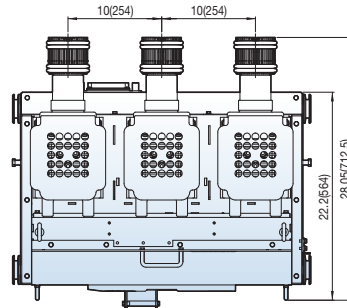

[Unit: in(mm)]

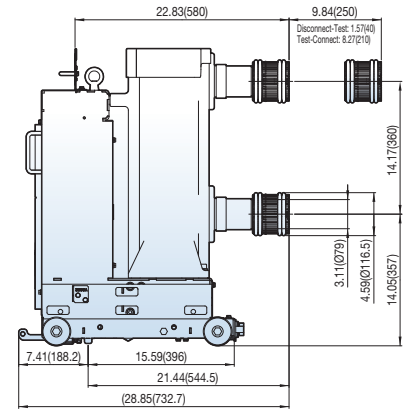
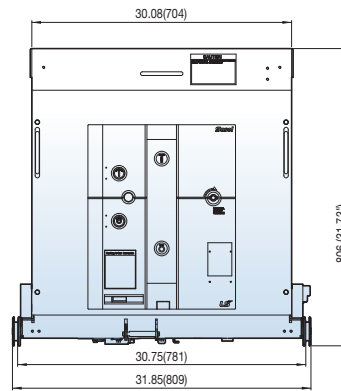

4.76/15kV, 25/31.5/40/50kA, 4000A

Circuit breaker model

- UVH-05H25L40
- UVH-05H32L40
- UVH-05H40L40
- UVH-05H50L40
- UVH-15H25L40
- UVH-15H32L40
- UVH-15H40L40
- UVH-15H50L40

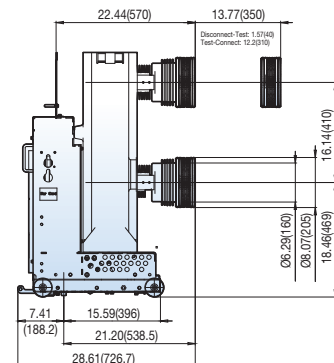
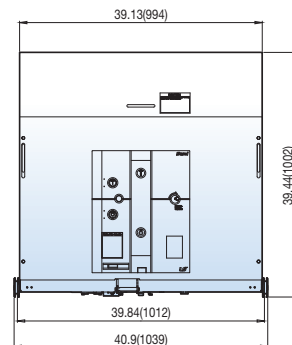
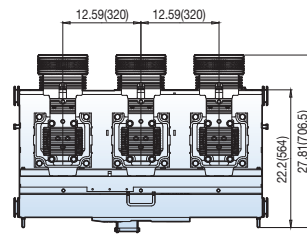

Dimensions

27kV, 31.5/40kA, 1200A

UVH type, Draw-out type

[Unit: in(mm)]

Circuit breaker model

- UVH-27H32C12
- UVH-27H40C12

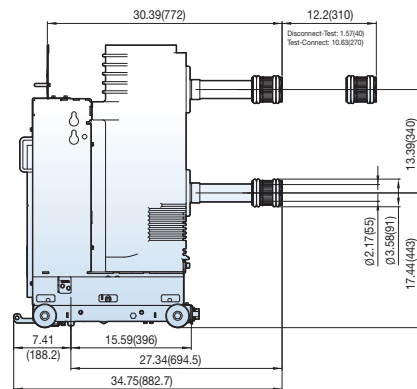
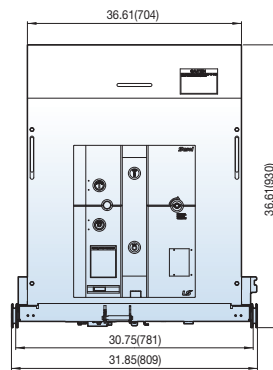
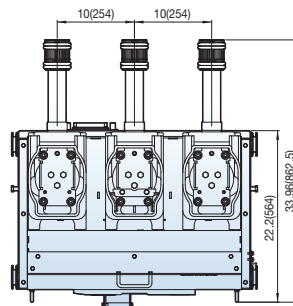

27kV, 31.5/40kA, 2000A

Circuit breaker model

- UVH-27H32C20
- UVH-27H40C20

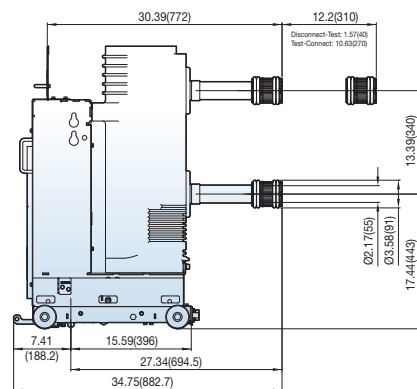
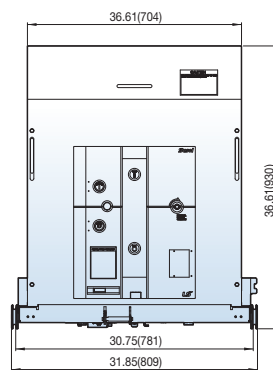
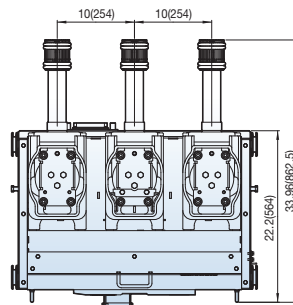

27kV, 25/31.5/40kA, 2500A

UVH type, Draw-out type

Circuit breaker model

- UVH-27H25C25
- UVH-27H32C25
- UVH-27H40C25

[Unit: in(mm)]

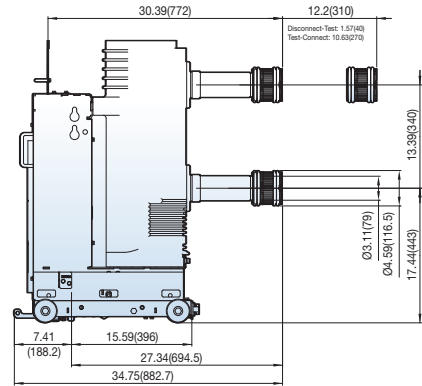
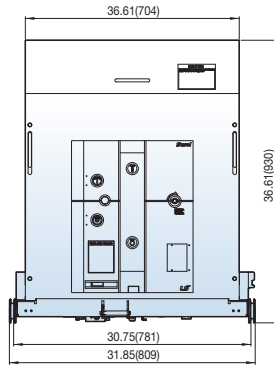
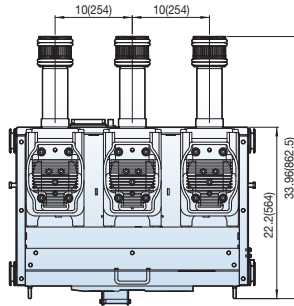

27kV, 25/31.5/40kA, 2750A

Circuit breaker model

- UVH-27H25C28
- UVH-27H32C28
- UVH-27H40C28

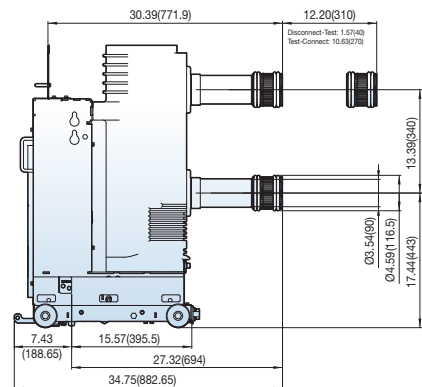
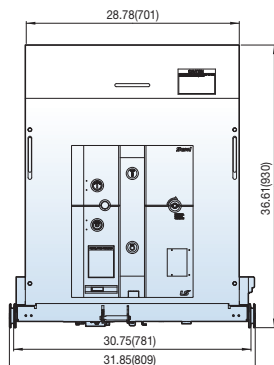
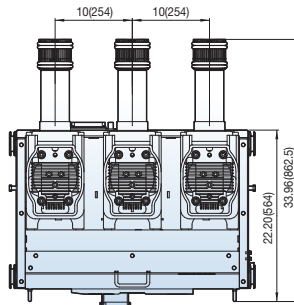

Dimensions

38kV, 31.5/40kA, 1200/2000A

UVH type, Draw-out type

[Unit: in(mm)]

Circuit breaker model

- UVH-38H32E12
- UVH-38H32E20
- UVH-38H40E12
- UVH-38H40E20

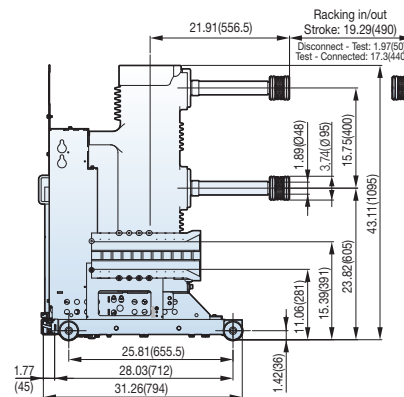
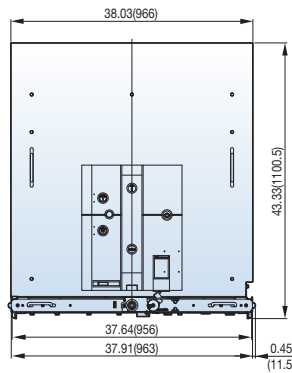
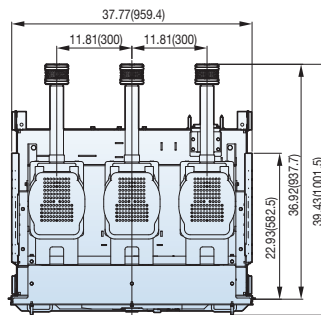

38kV, 31.5/40kA, 3000A

Circuit breaker model

- UVH-38H32E30
- UVH-38H40E30

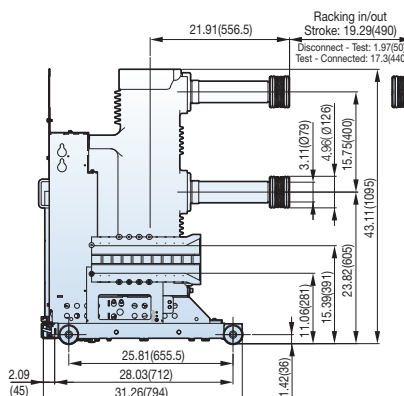
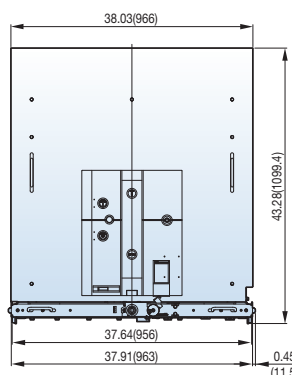
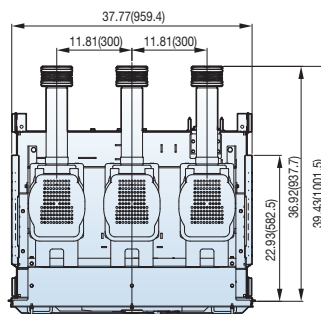

4.76/15kV, 40kA, 1200A

UVH type, Draw-out type

Cradle model

UVCH-05L40A12
UVCH-15L40A12

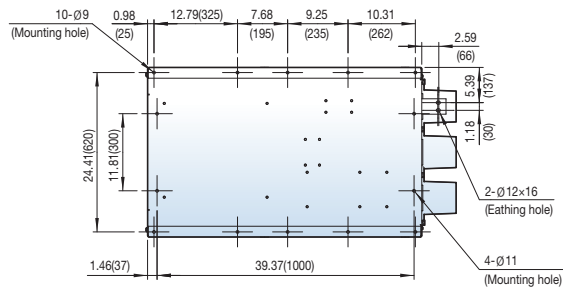
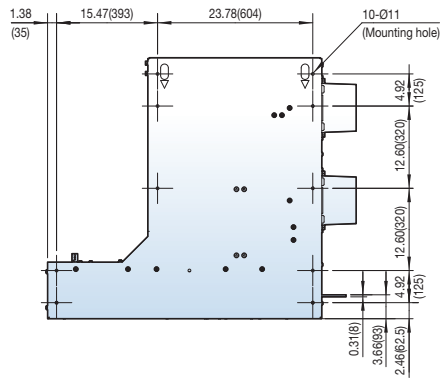
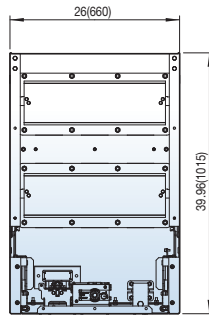
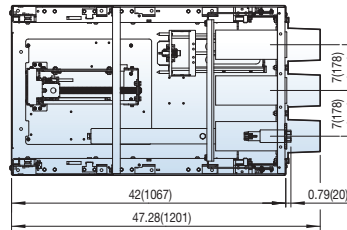
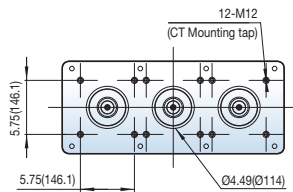

[Unit: in(mm)]

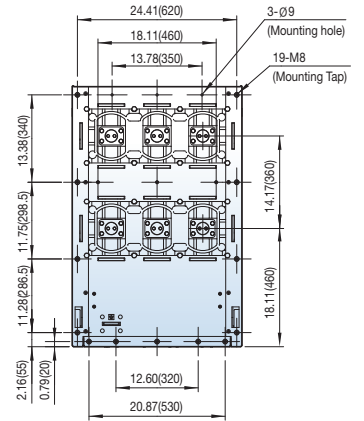
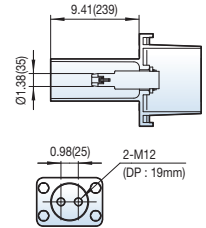

Dimensions

4.76/15kV, 40kA, 1200A

UVH type, Draw-out type

Cradle model

UVCH-05L40C12
UVCH-15L40C12

[Unit: in(mm)]

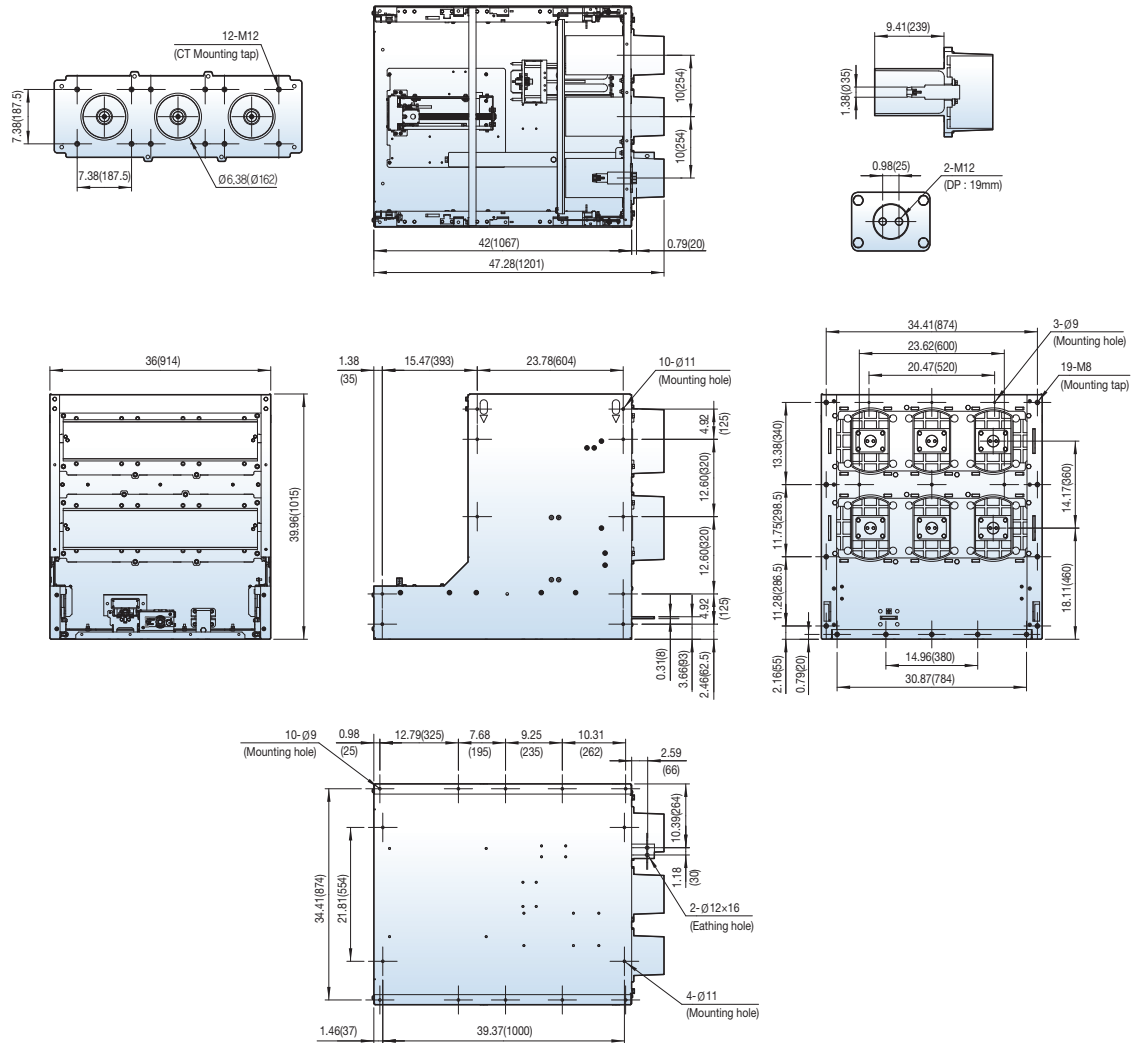

4.76/15kV, 40kA, 1200A

UVH type, Draw-out type

Cradle model

UVCH-05C40A12
UVCH-15C40A12

[Unit: in(mm)]

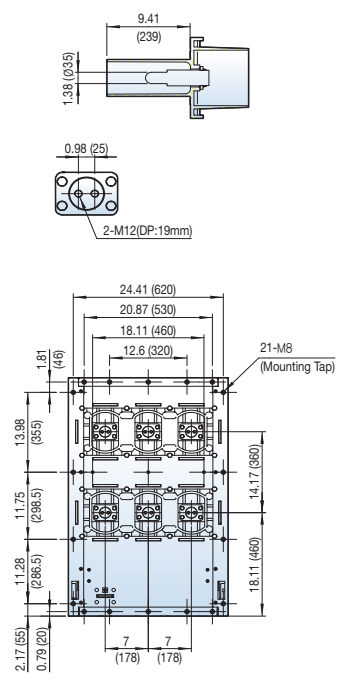
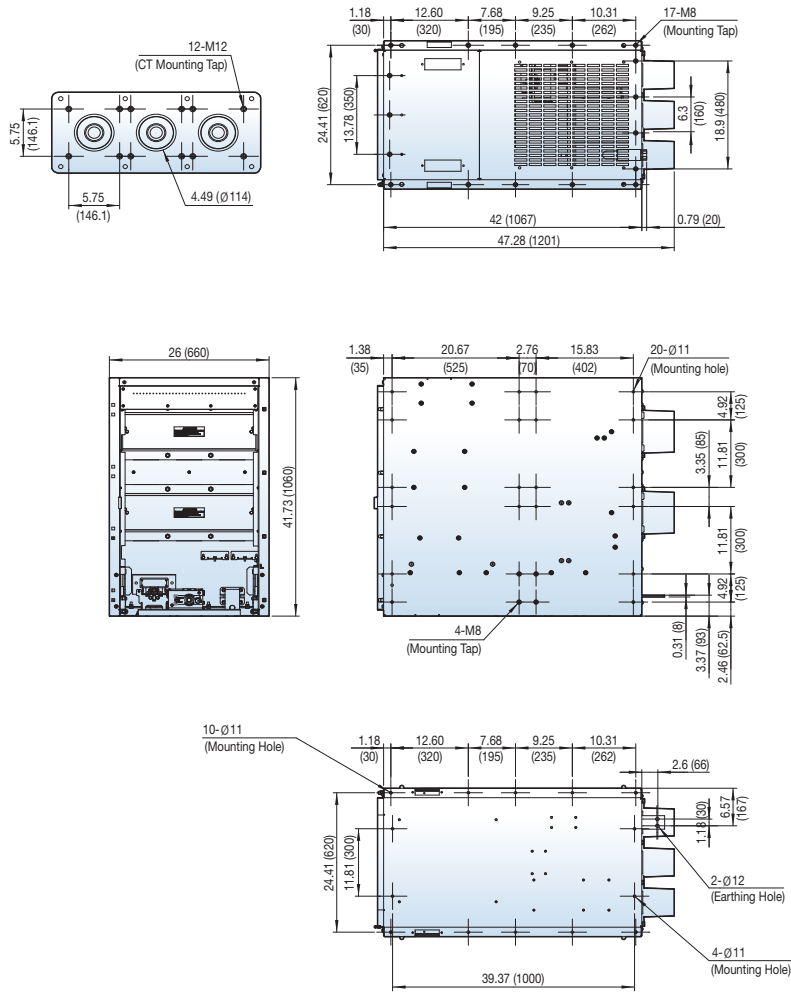

Dimensions

4.76/15kV, 40kA, 1200A

UVH type, Draw-out type

Cradle model

UVCH-05C40C12
UVCH-15C40C12

[Unit: in(mm)]

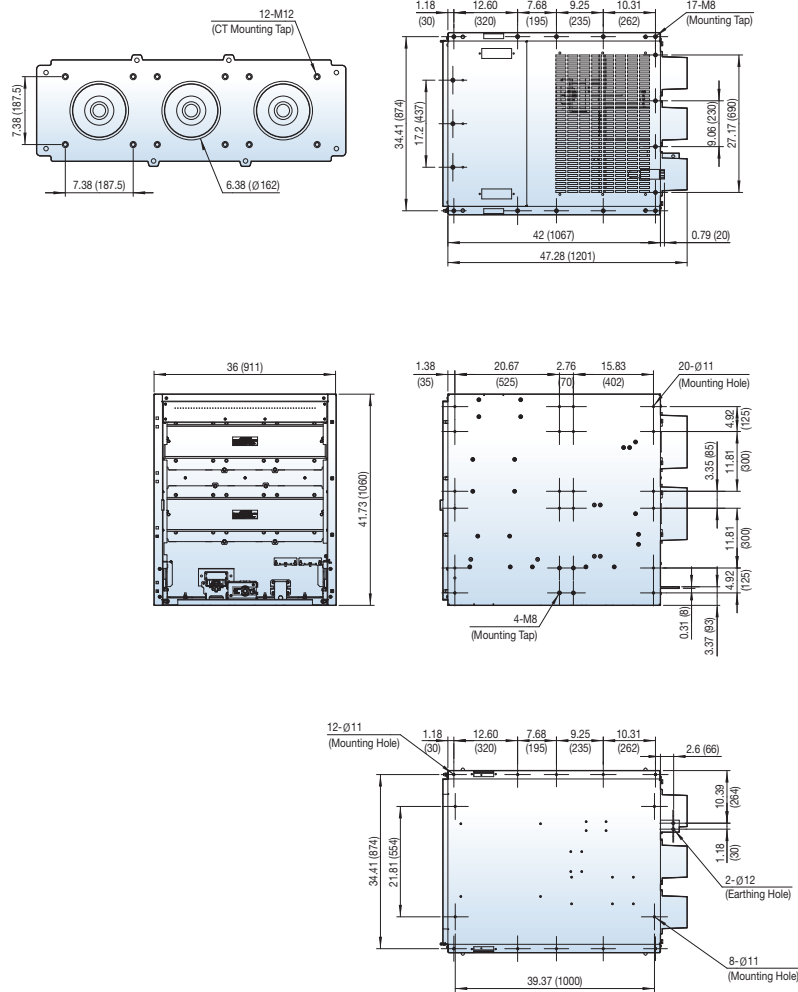

4.76/15kV, 40kA, 1200A

UVH type, Draw-out type

Cradle model

UVCH-05H40A12
UVCH-15H40A12

[Unit: in(mm)]

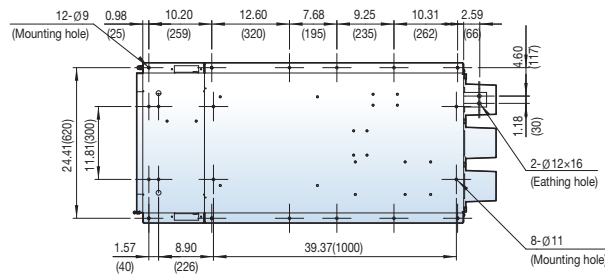
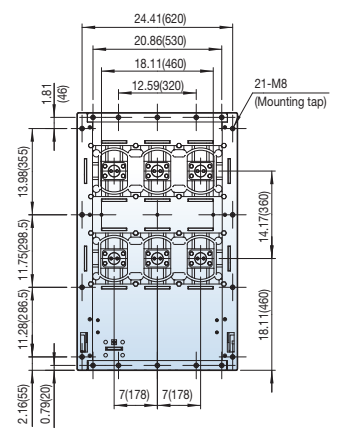
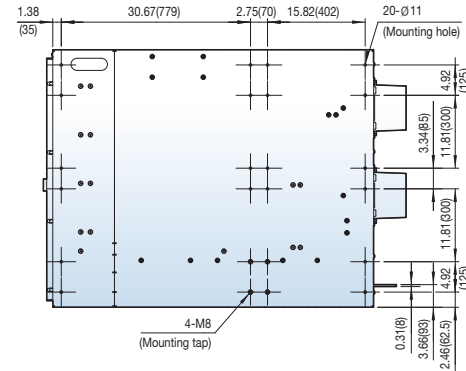
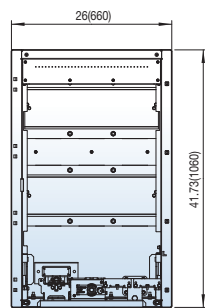
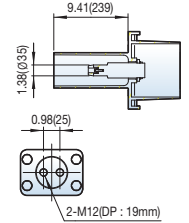
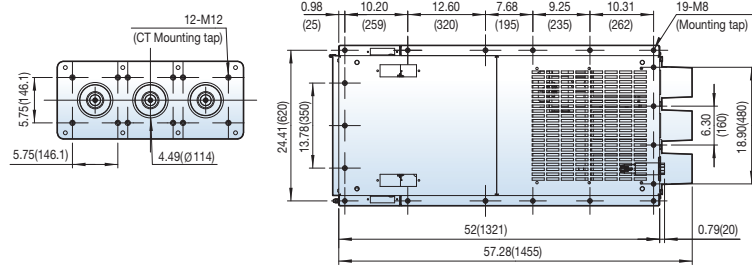

Dimensions

4.76/15kV, 40kA, 1200A

UVH type, Draw-out type

Cradle model

UVCH-05H40C12
UVCH-15H40C12

[Unit: in(mm)]

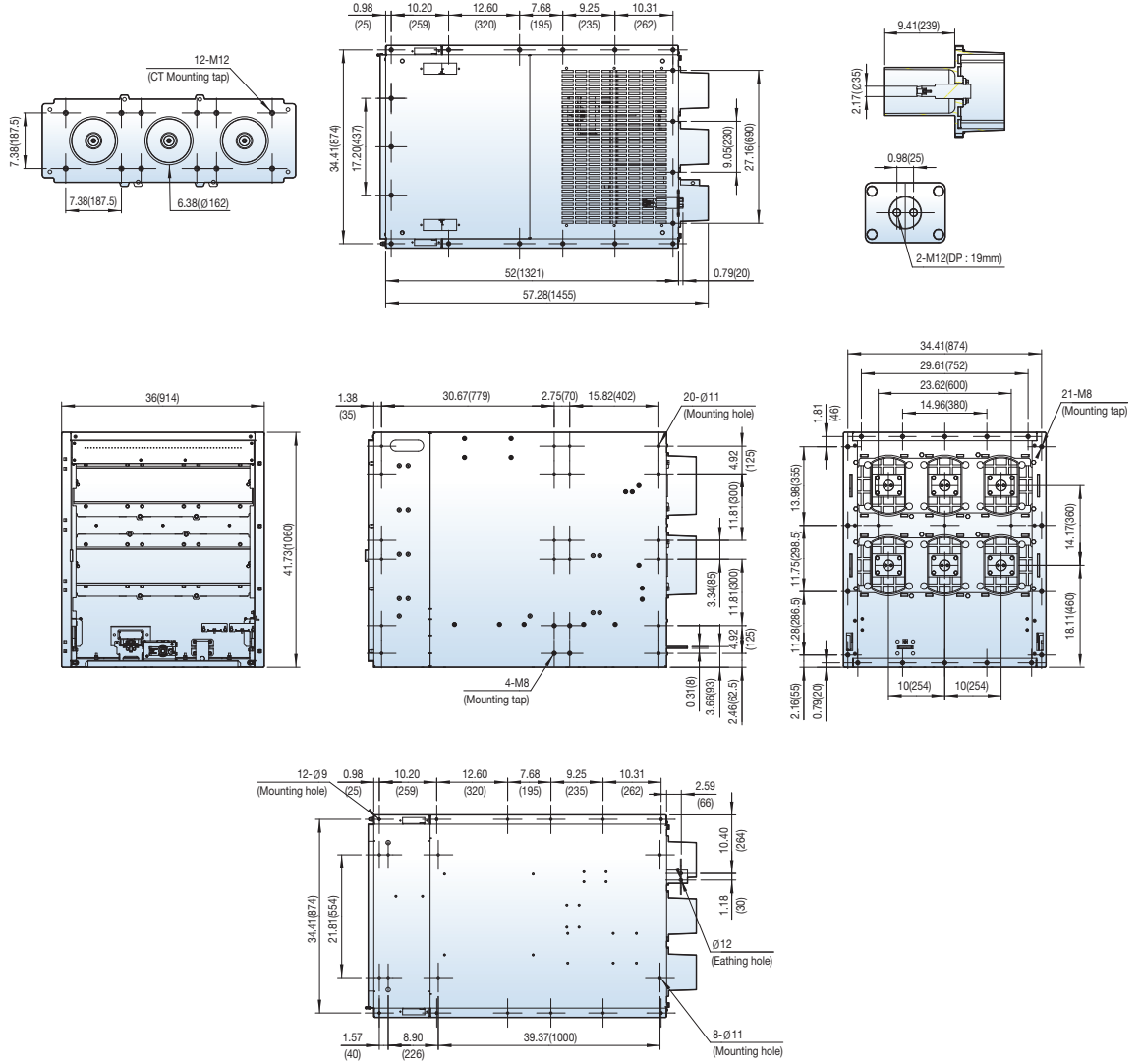

4.76/15kV, 50kA, 1200A

Cradle model

UVCH-05L50A12
UVCH-15L50A12

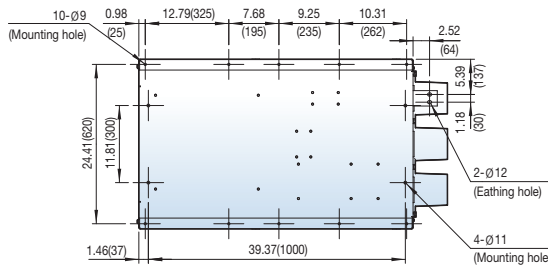
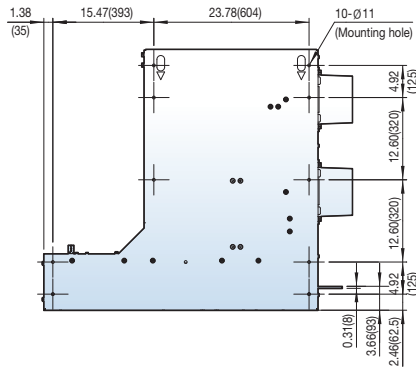
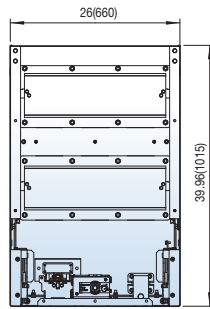
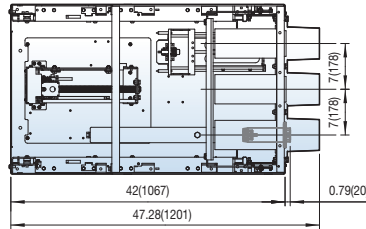
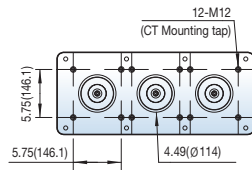

UVH type, Draw-out type

[Unit: in(mm)]

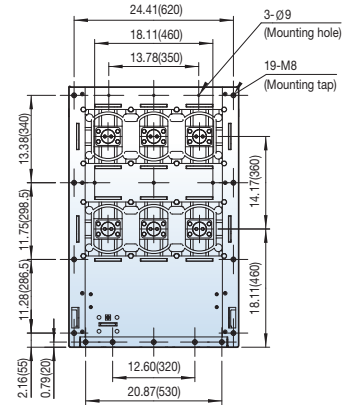
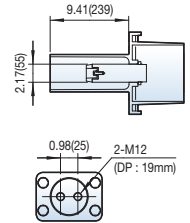

Dimensions

4.76/15kV, 50kA, 1200A

UVH type, Draw-out type

Cradle model

UVCH-05L50C12
UVCH-15L50C12

[Unit: in(mm)]

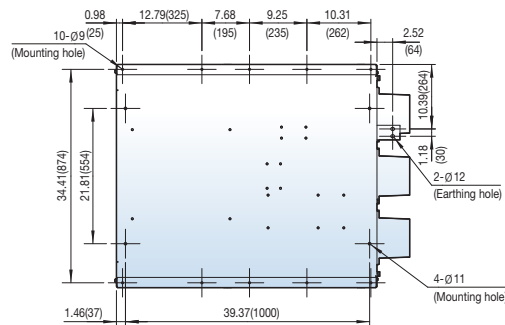
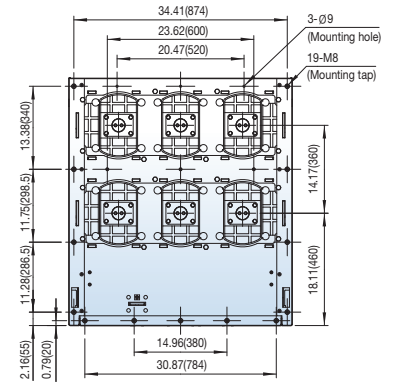
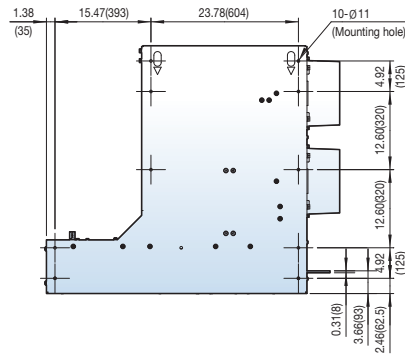
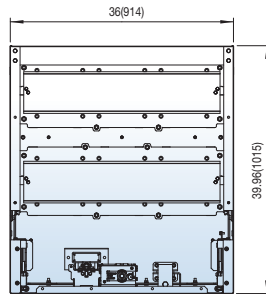
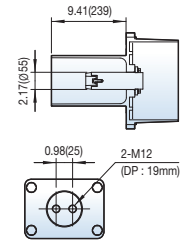
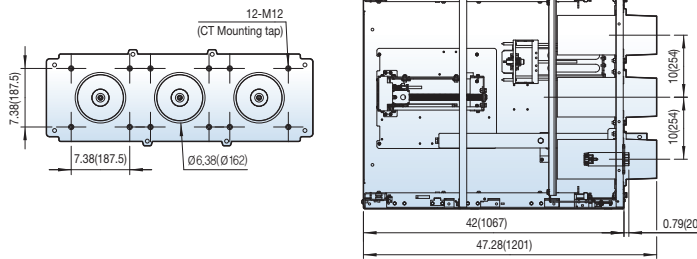

4.76/15kV, 50kA, 1200A

UVH type, Draw-out type

Cradle model

UVCH-05C50A12
UVCH-15C50A12

[Unit: in(mm)]

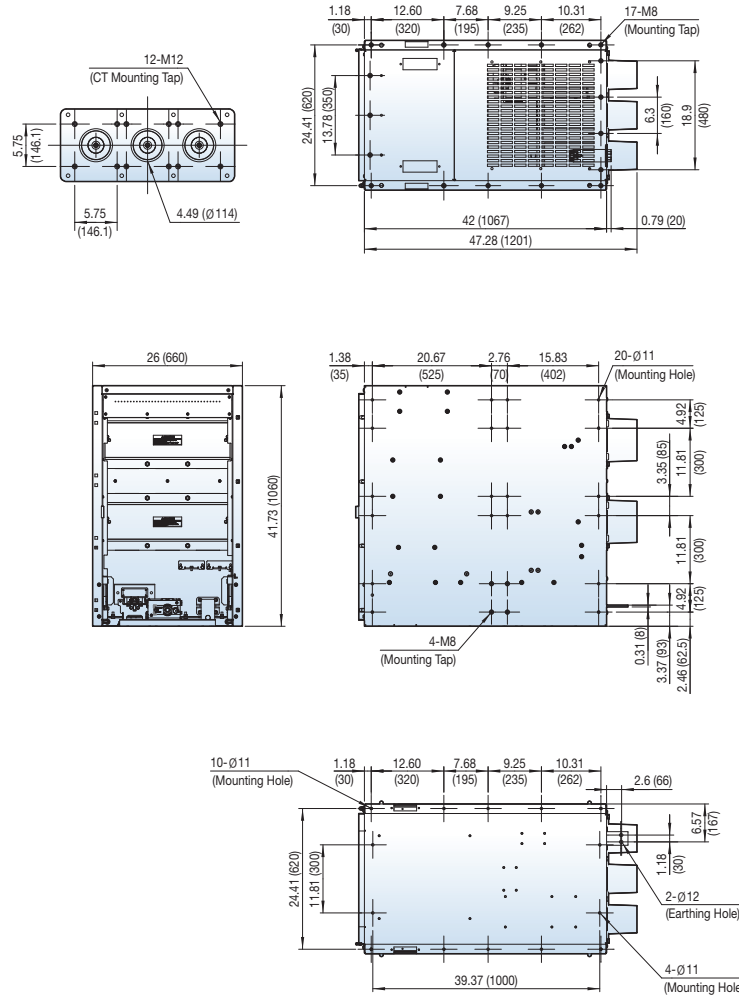

Dimensions

4.76/15kV, 50kA, 1200A

UVH type, Draw-out type

Cradle model

UVCH-05C50C12
UVCH-15C50C12

[Unit: in(mm)]

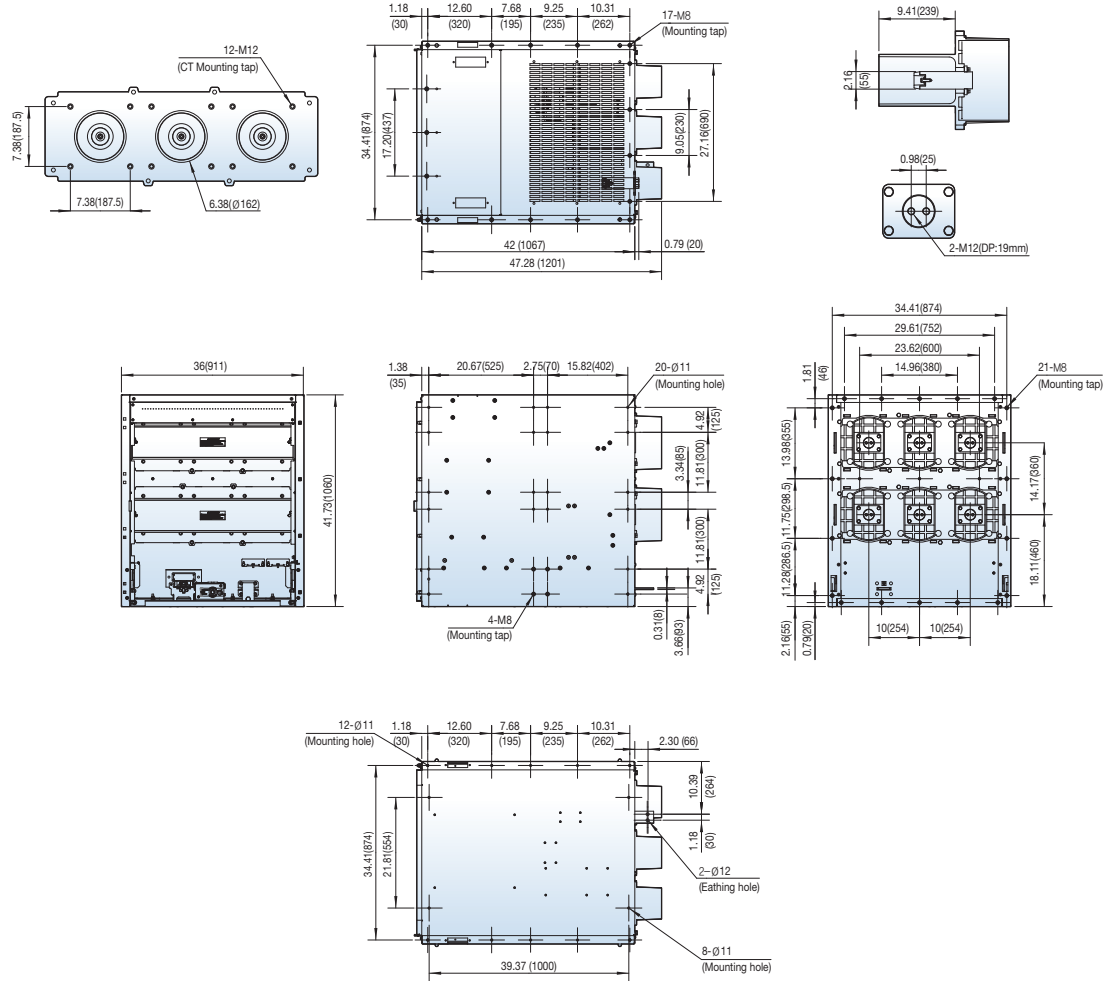

4.76/15kV, 50kA, 1200A

UVH type, Draw-out type

Cradle model

UVCH-05H50A12
UVCH-15H50A12

[Unit: in(mm)]

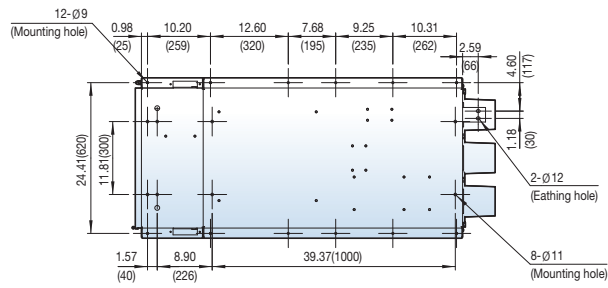
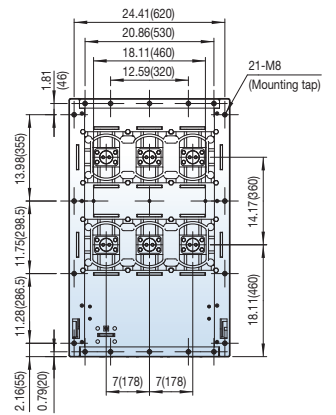
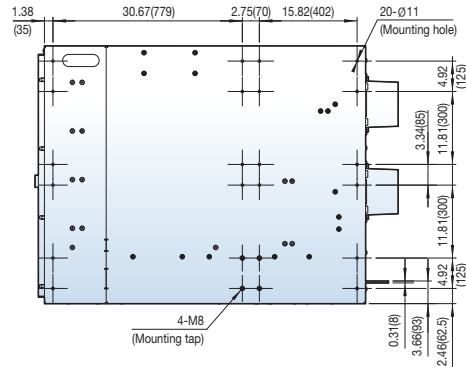
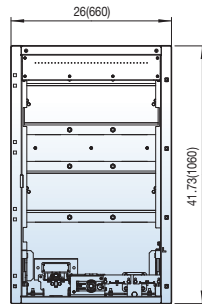
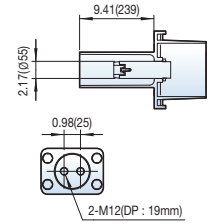
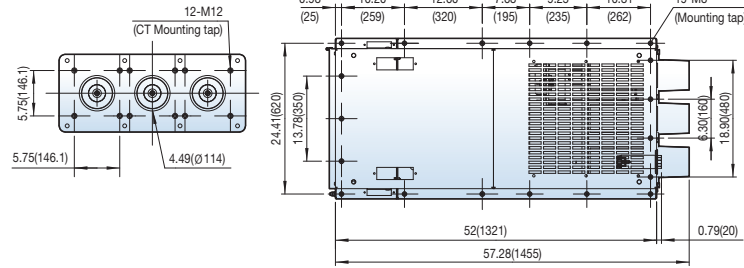

Dimensions

4.76/15kV, 50kA, 1200A

UVH type, Draw-out type

[Unit: in(mm)]

Cradle model

UVCH-05H50C12
UVCH-15H50C12

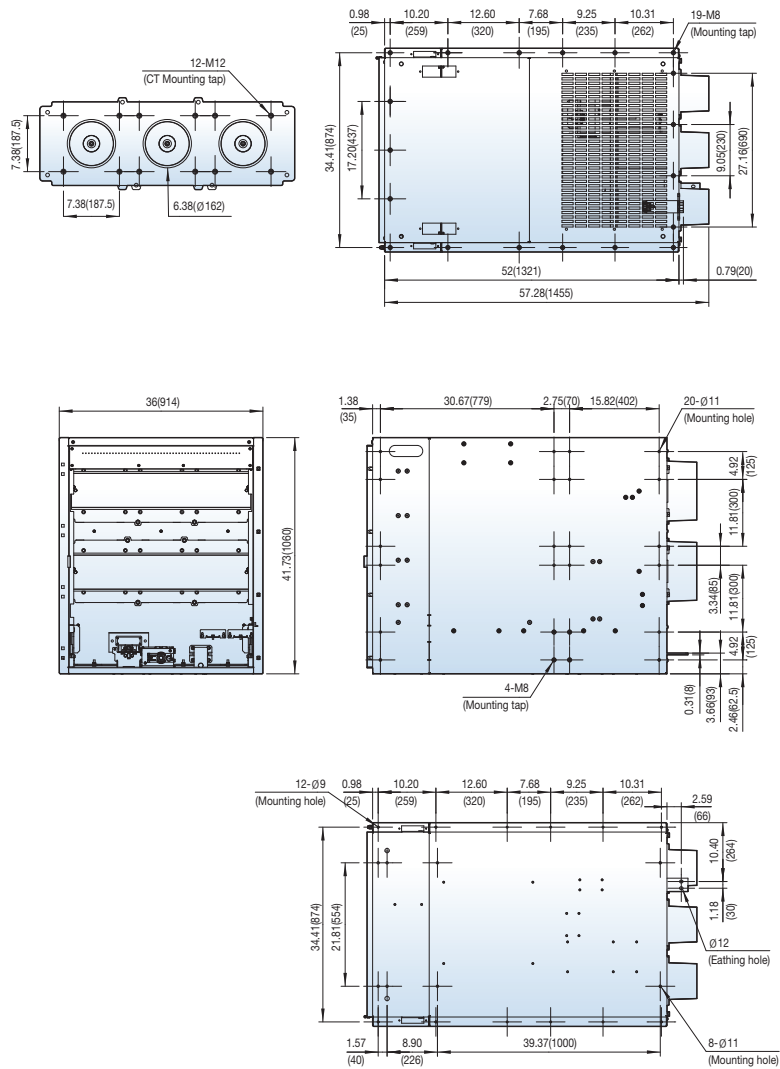

4.76/15kV, 40/50kA, 2000A

UVH type, Draw-out type

Cradle model

- UVCH-05L40A20
- UVCH-05L50A20
- UVCH-15L40A20
- UVCH-15L50A20

[Unit: in(mm)]

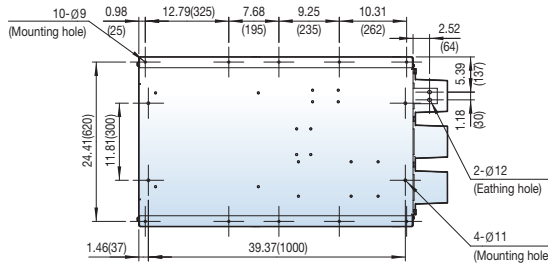
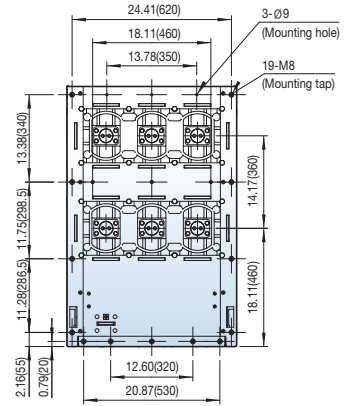
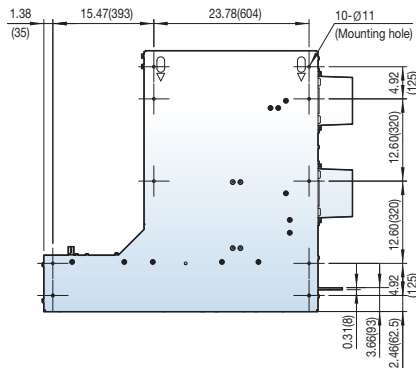
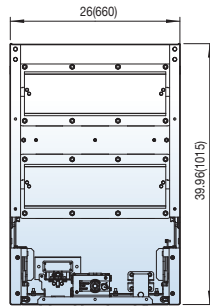
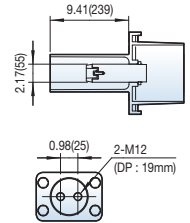
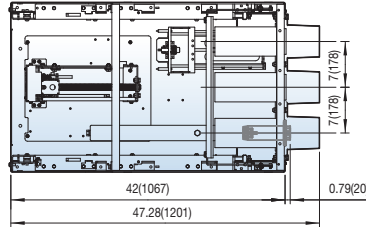
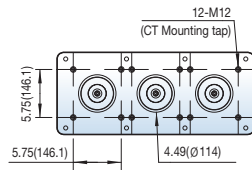

Dimensions

4.76/15kV, 40/50kA, 2000A

UVH type, Draw-out type

Cradle model

- UVCH-05L40C20
- UVCH-05L50C20
- UVCH-15L40C20
- UVCH-15L50C20

[Unit: in(mm)]

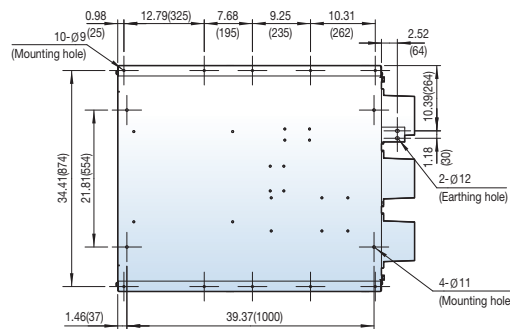
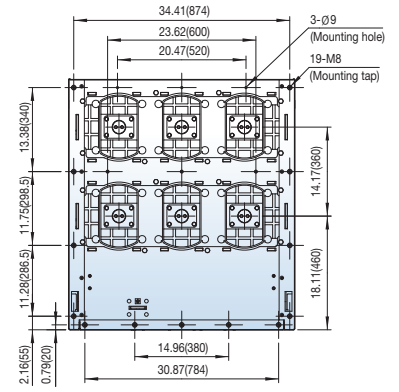
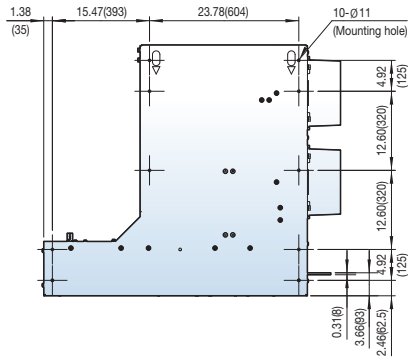
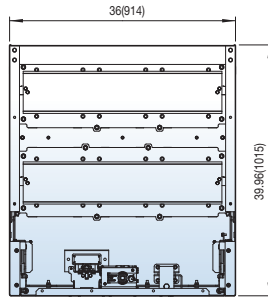
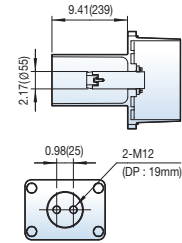
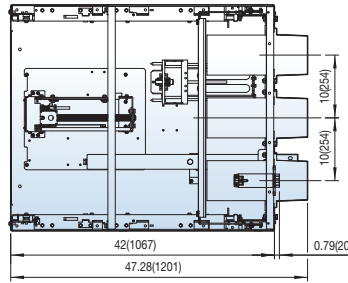
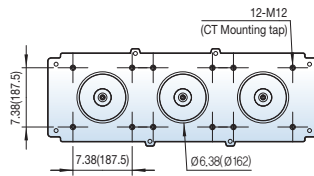

4.76/15kV, 40/50kA, 2000A

Cradle model

- UVCH-05C40A20
- UVCH-05C50A20
- UVCH-15C40A20
- UVCH-15C50A20

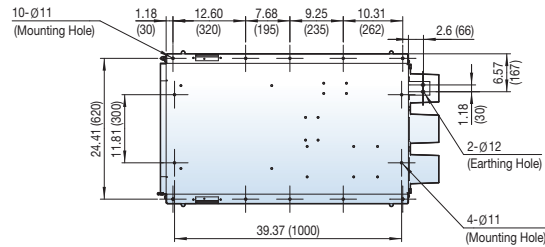
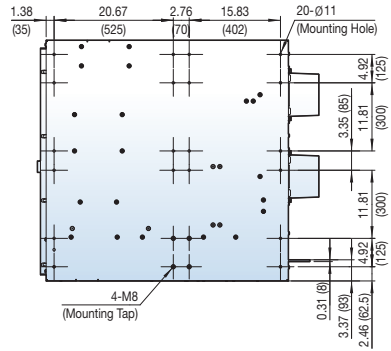
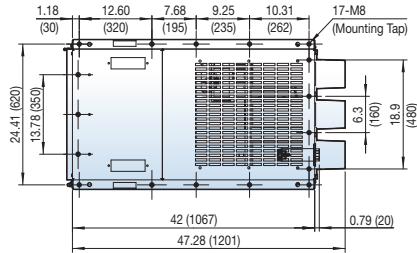
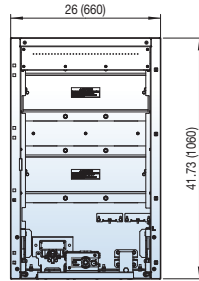
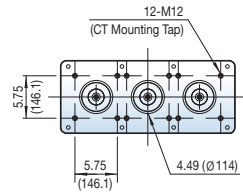

UVH type, Draw-out type

[Unit: in(mm)]

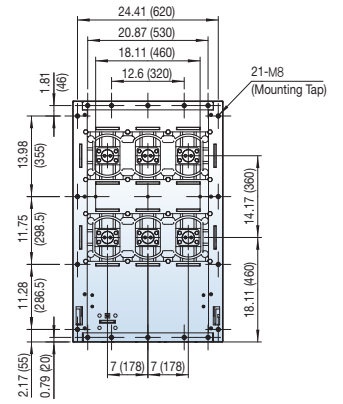
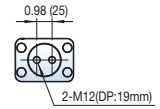
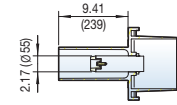

Dimensions

4.76/15kV, 40/50kA, 2000A

UVH type, Draw-out type

Cradle model

- UVCH-05C40C20
- UVCH-05C50C20
- UVCH-15C40C20
- UVCH-15C50C20

[Unit: in(mm)]

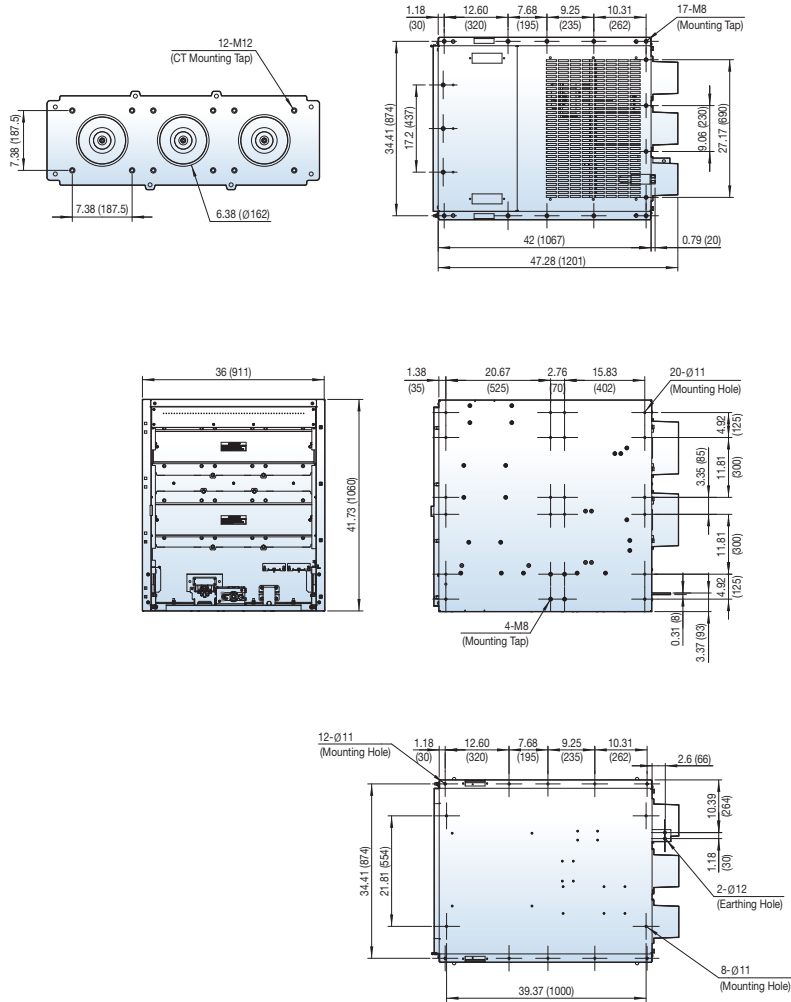

4.76/15kV, 40/50kA, 2000A

UVH type, Draw-out type

Cradle model

- UVCH-05H40A20
- UVCH-05H50A20
- UVCH-15H40A20
- UVCH-15H50A20

[Unit: in(mm)]

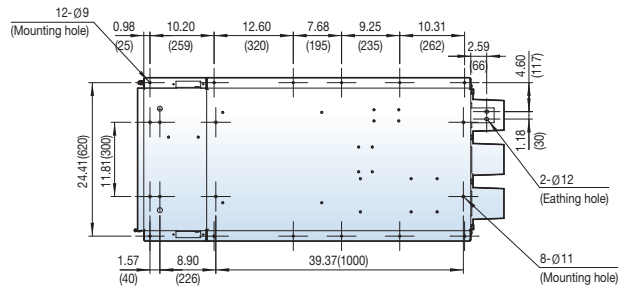
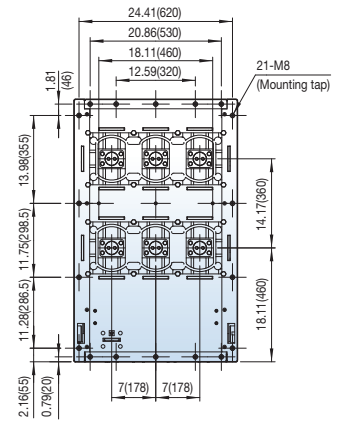
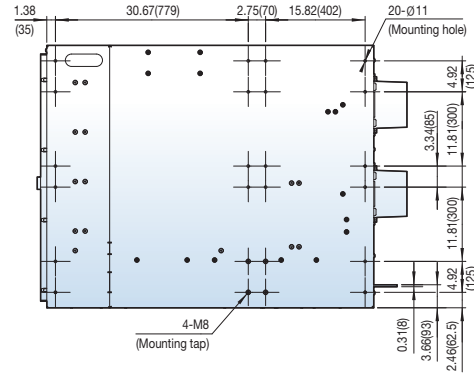
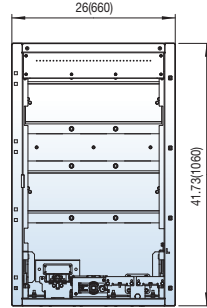
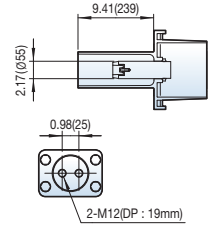
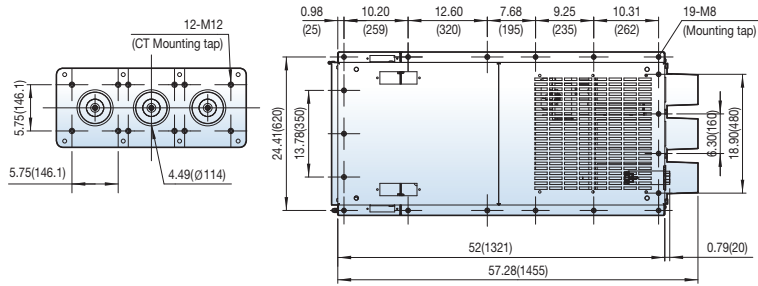

Dimensions

4.76/15kV, 40/50kA, 2000A

UVH type, Draw-out type

Cradle model

- UVCH-05H40C20
- UVCH-05H50C20
- UVCH-15H40C20
- UVCH-15H50C20

[Unit: in(mm)]

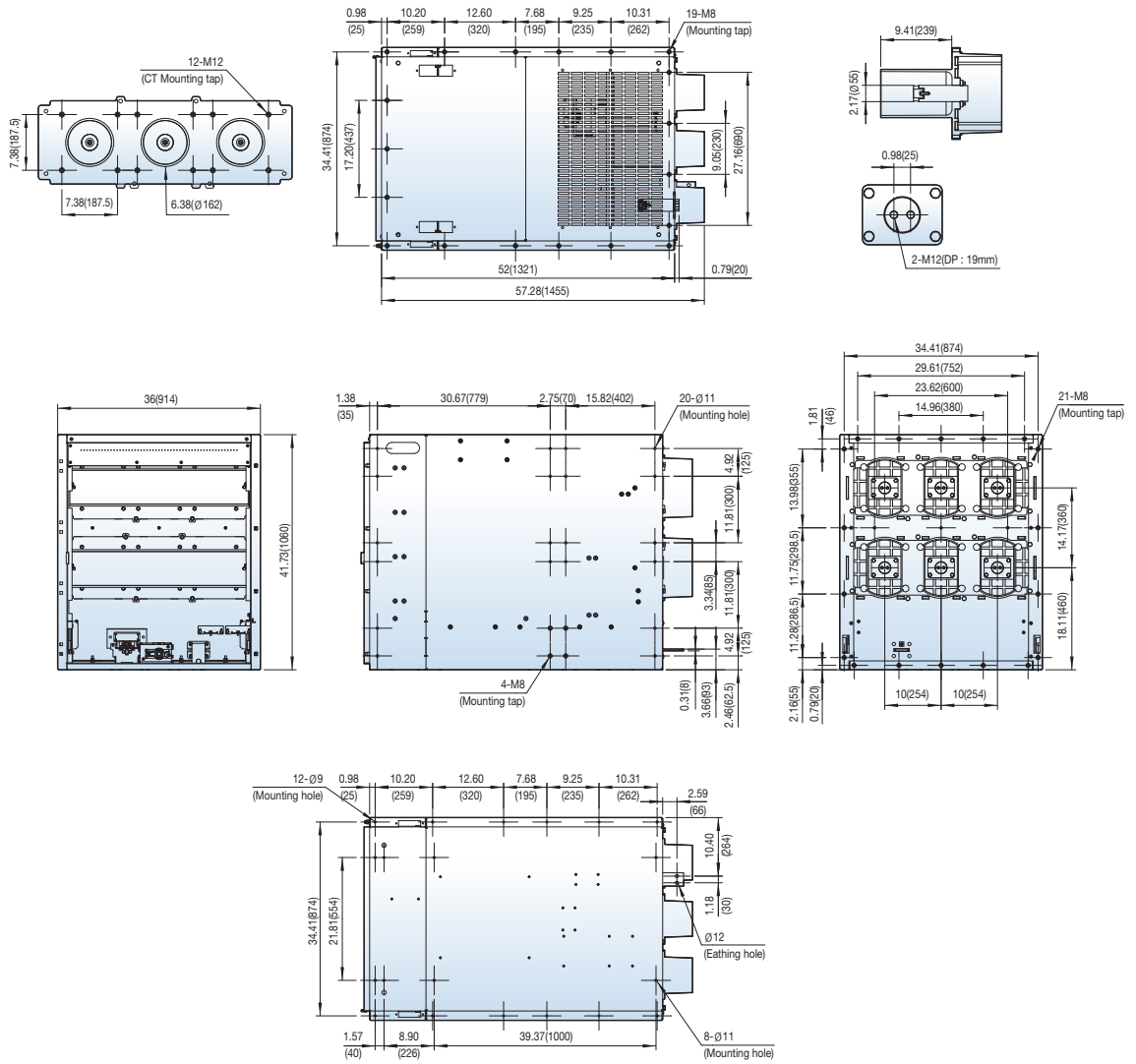

4.76/15kV, 25/31.5/40/50kA, 3000A

UVH type, Draw-out type

Cradle model

- UVCH-05L25C30
- UVCH-05L32C30
- UVCH-05L40C30
- UVCH-05L50C30
- UVCH-15L25C30
- UVCH-15L32C30
- UVCH-15L40C30
- UVCH-15L50C30

[Unit: in(mm)]

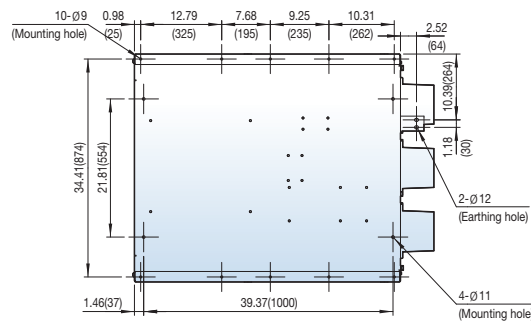
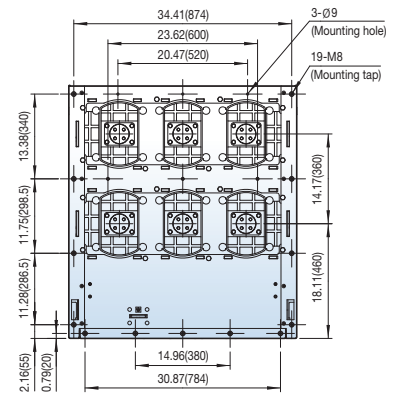
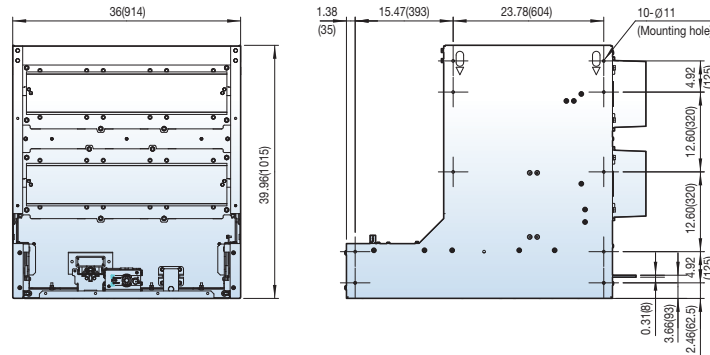
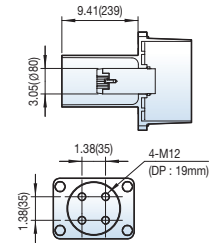
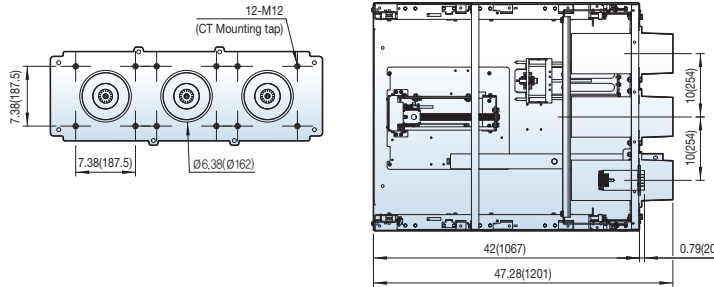

Dimensions

4.76/15kV, 25/31.5/40/50kA, 3000A

UVH type, Draw-out type

Cradle model

- UVCH-05C25C30
- UVCH-05C32C30
- UVCH-05C40C30
- UVCH-05C50C30
- UVCH-15C25C30
- UVCH-15C32C30
- UVCH-15C40C30
- UVCH-15C50C30

[Unit: in(mm)]

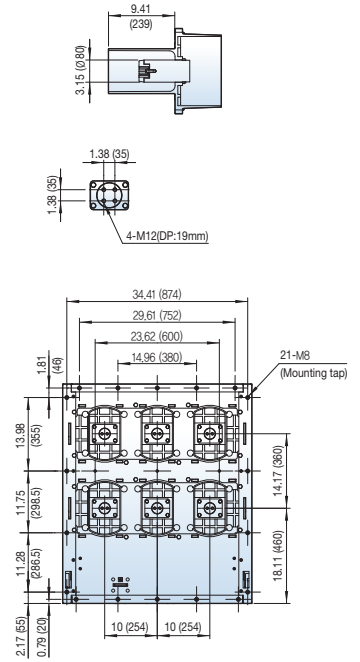
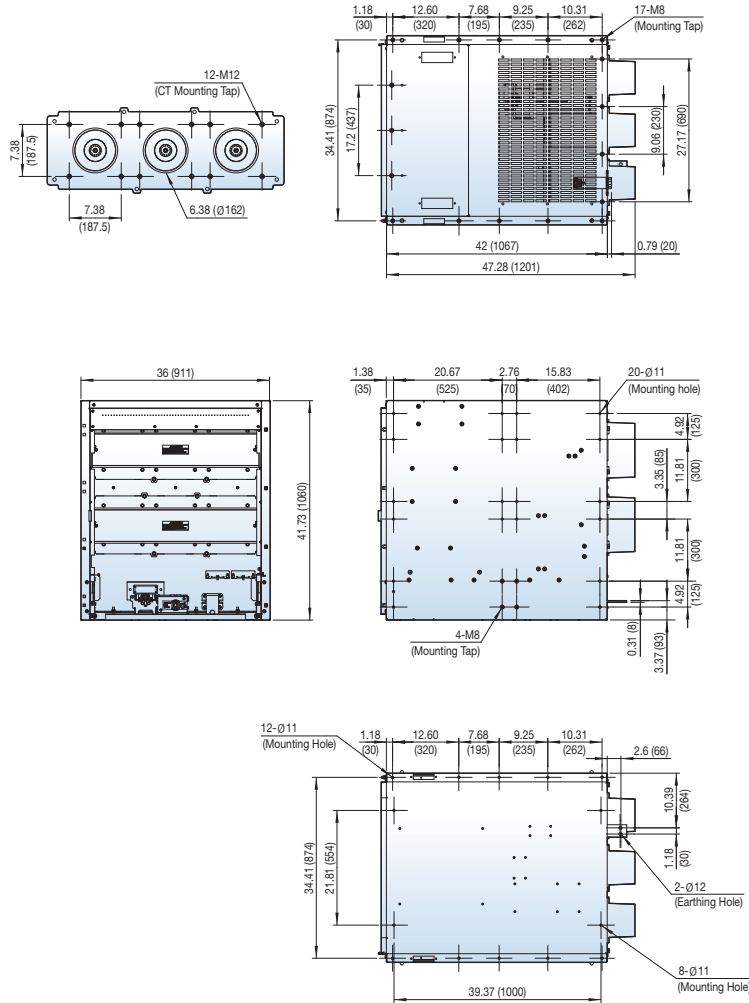

4.76/15kV, 25/31.5/40/50kA, 3000A

UVH type, Draw-out type

Cradle model

- UVCH-05H25C30
- UVCH-05H32C30
- UVCH-05H40C30
- UVCH-05H50C30
- UVCH-15H25C30
- UVCH-15H32C30
- UVCH-15H40C30
- UVCH-15H50C30

[Unit: in(mm)]

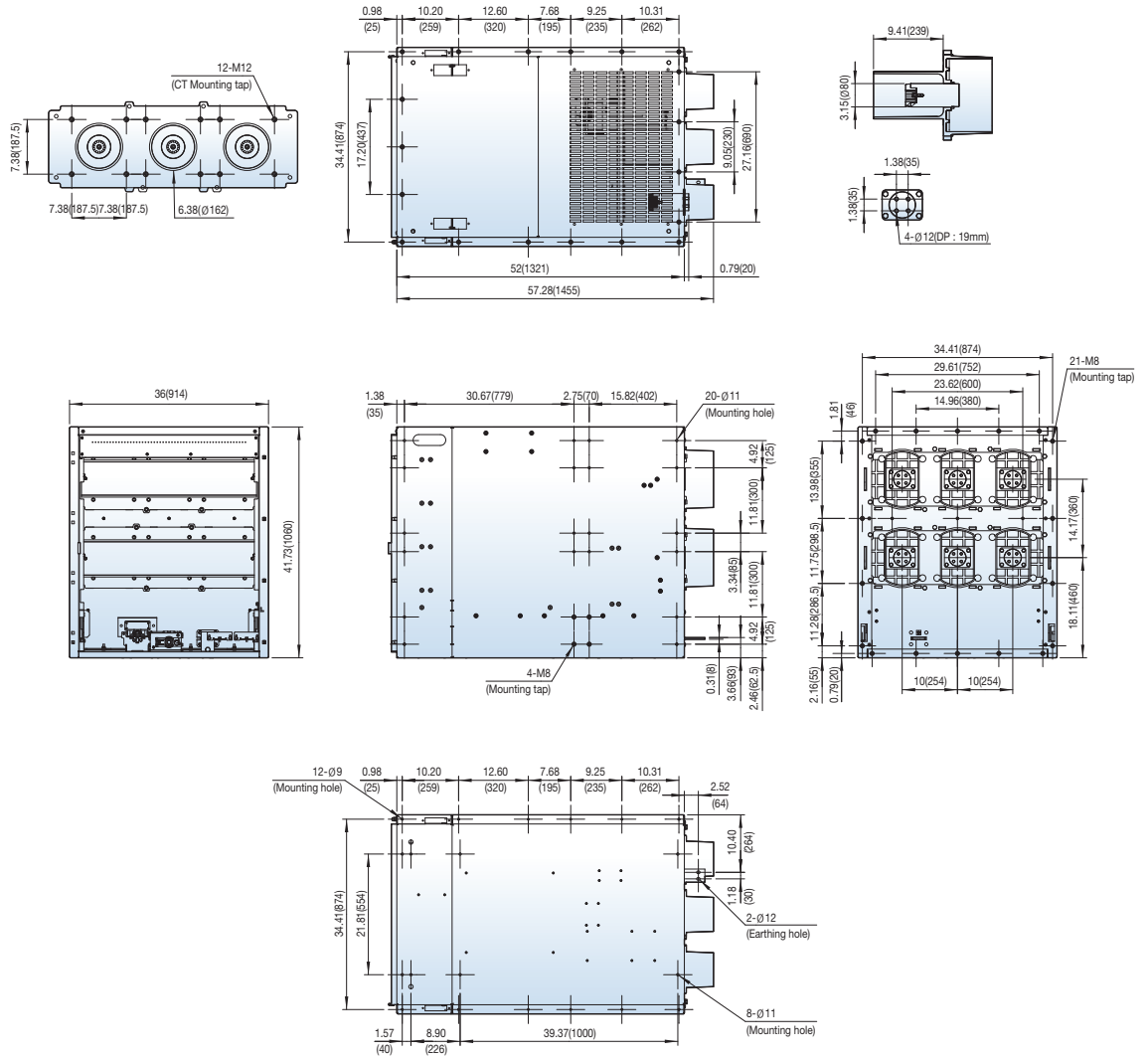

Dimensions

4.76/15kV, 25/31.5/40/50kA, 4000A

UVH type, Draw-out type

Cradle model

- UVCH-05L25L40
- UVCH-05L32L40
- UVCH-05L40L40
- UVCH-05L50L40
- UVCH-15L25L40
- UVCH-15L32L40
- UVCH-15L40L40
- UVCH-15L50L40

[Unit: in(mm)]

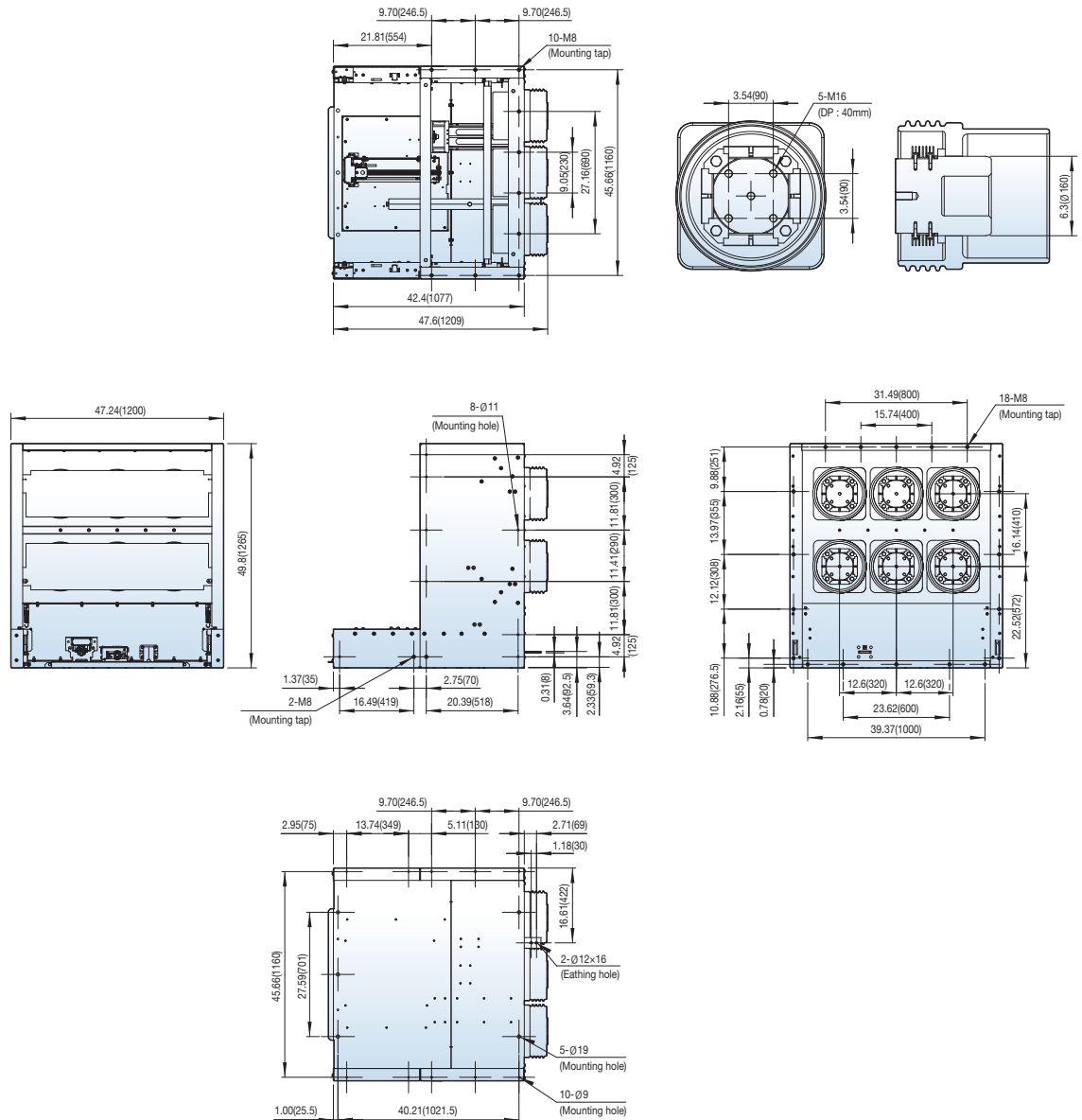

4.76/15kV, 25/31.5/40/50kA, 4000A

UVH type, Draw-out type

Cradle model

- UVCH-05H25L40
- UVCH-05H32L40
- UVCH-05H40L40
- UVCH-05H50L40
- UVCH-15H25L40
- UVCH-15H32L40
- UVCH-15H40L40
- UVCH-15H50L40

[Unit: in(mm)]

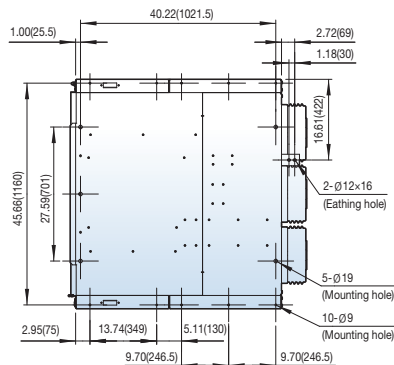
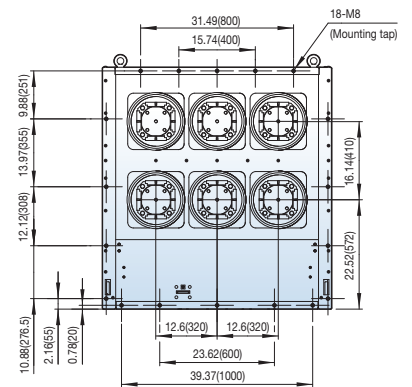
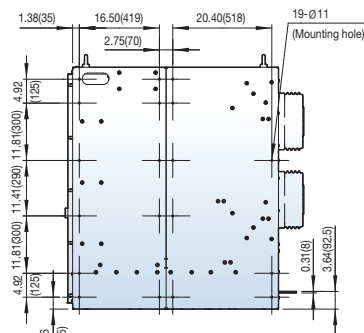
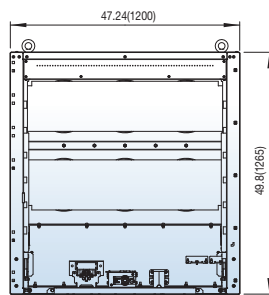
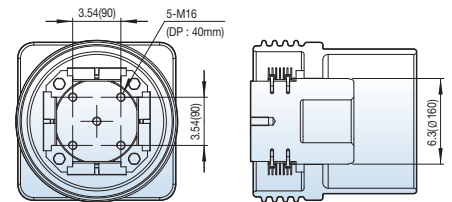
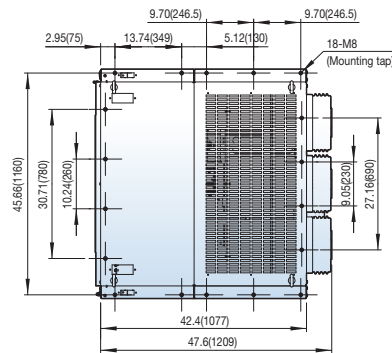

Dimensions

27kV, 31.5/40kA, 1200A

UVH type, Draw-out type

Cradle model

UVCH-27L32C12
UVCH-27L40C12

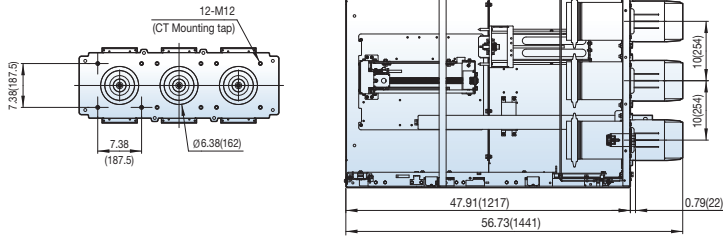

[Unit: in(mm)]

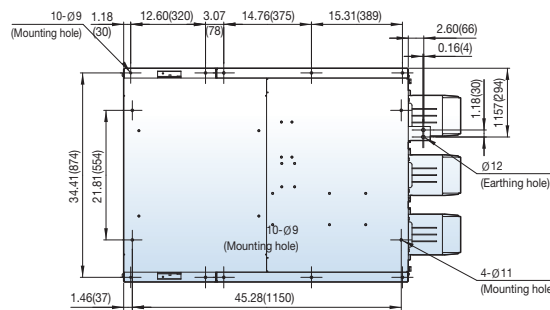
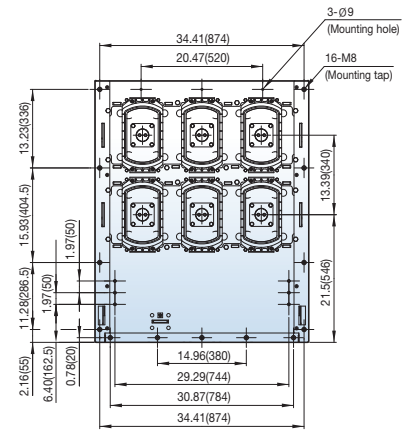
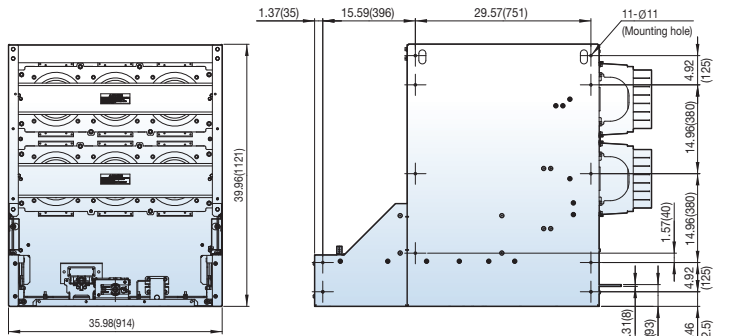
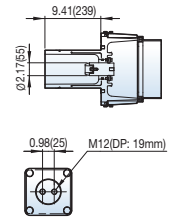

27kV, 31.5/40kA, 2000A

UVH type, Draw-out type

Cradle model

UVCH-27L32C20
UVCH-27L40C20

[Unit: in(mm)]

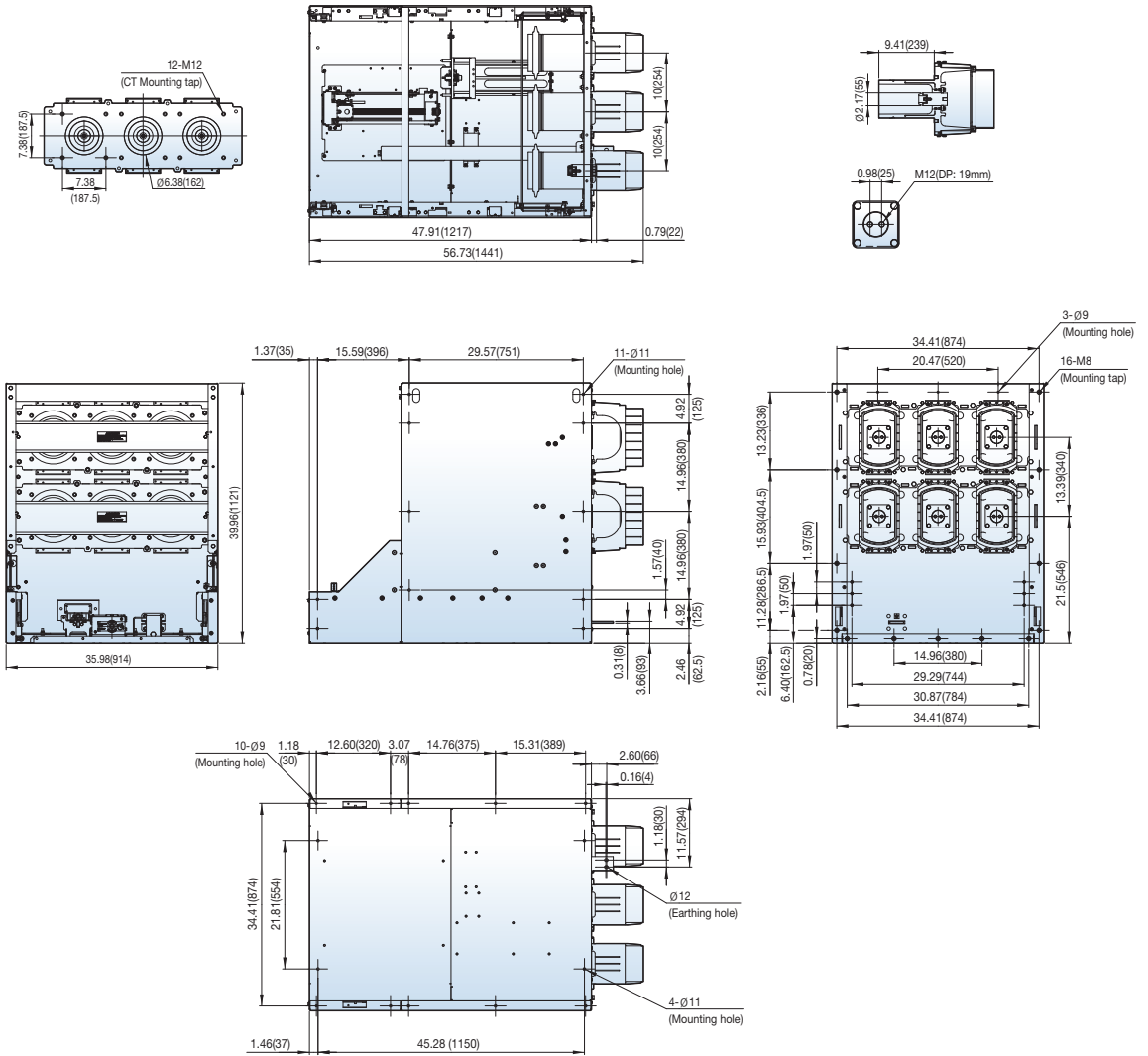

Dimensions

27kV, 25/31.5/40kA, 2500A

UVH type, Draw-out type

Cradle model

UVCH-27L25C25
 UVCH-27L32C25
 UVCH-27L40C25

[Unit: in(mm)]

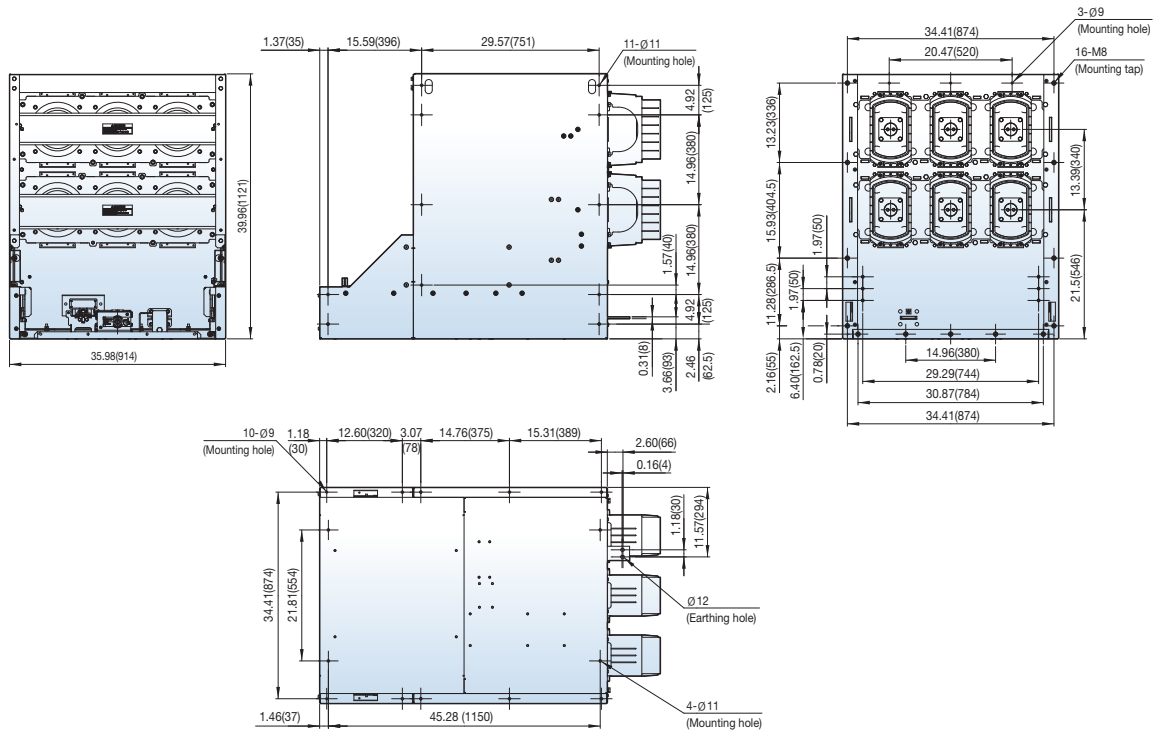
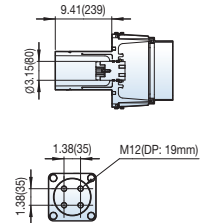
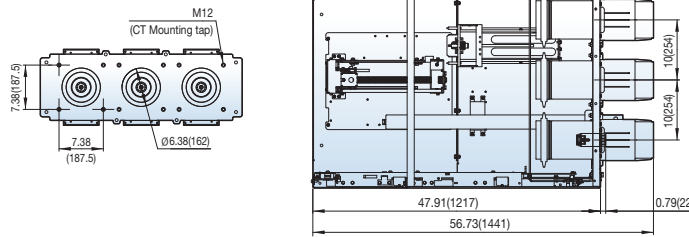

27kV, 25/31.5/40kA, 2750A

UVH type, Draw-out type

Cradle model

- UVCH-27L25C28
- UVCH-27L32C28
- UVCH-27L40C28

[Unit: in(mm)]

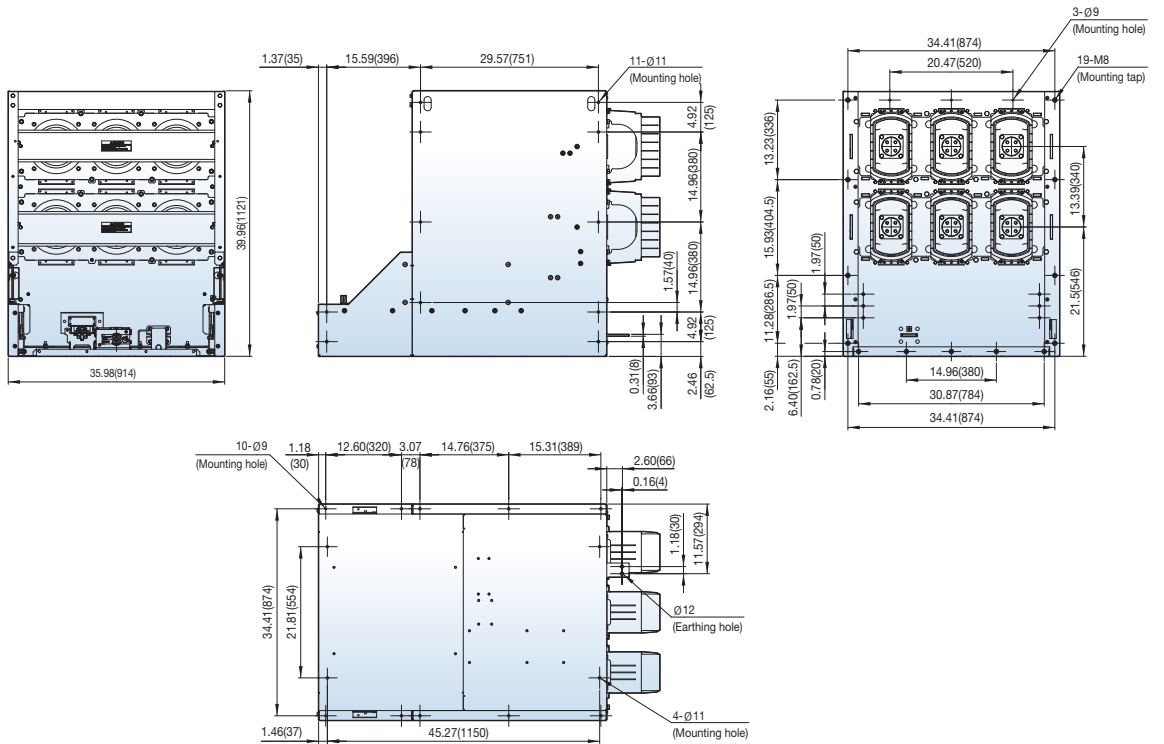
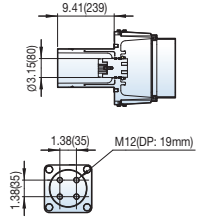
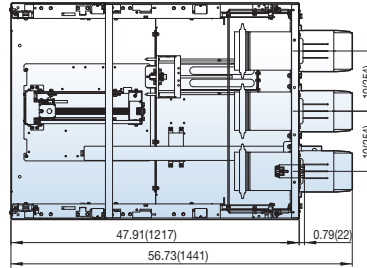
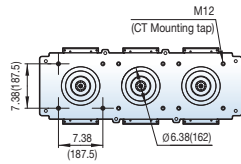

Dimensions

27kV, 31.5/40kA, 1200A

UVH type, Draw-out type

Cradle model

UVCH-27C32C12
UVCH-27C40C12

[Unit: in(mm)]

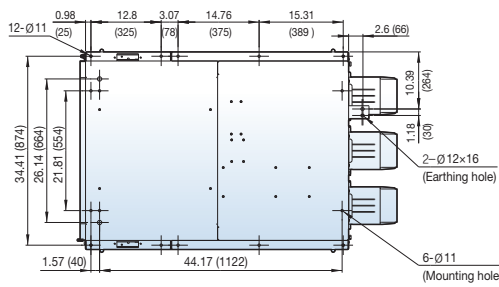
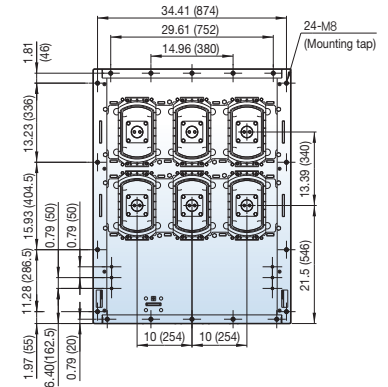
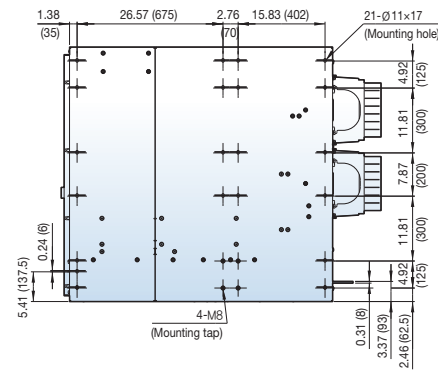
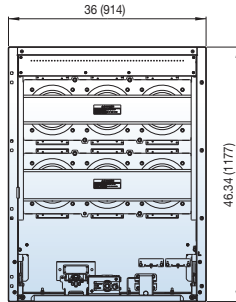
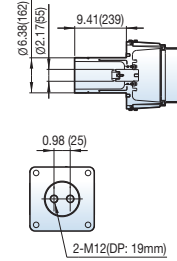
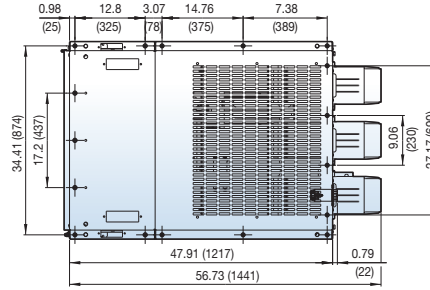
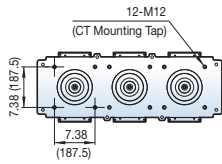

27kV, 31.5/40kA, 2000A

UVH type, Draw-out type

[Unit: in(mm)]

Cradle model

UVCH-27C32C20
UVCH-27C40C20

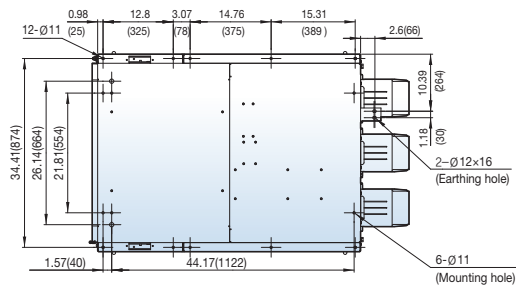
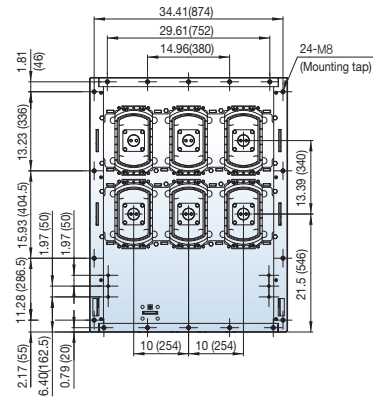
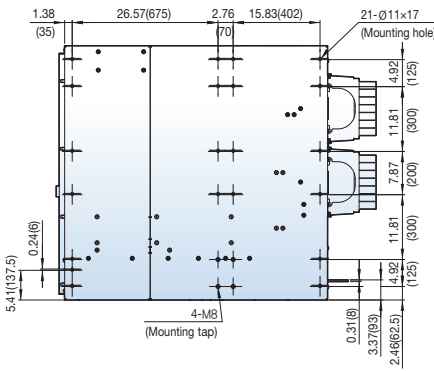
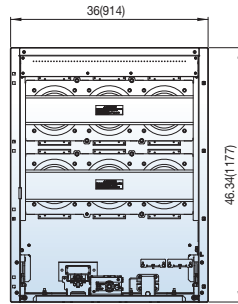
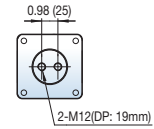
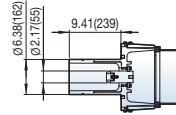
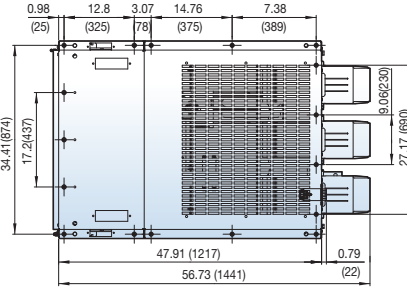
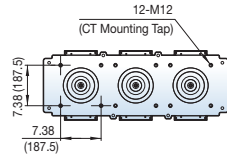

Dimensions

27kV, 25/31.5/40kA, 2500A

UVH type, Draw-out type

Cradle model

UVCH-27C25C25
 UVCH-27C32C25
 UVCH-27C40C25

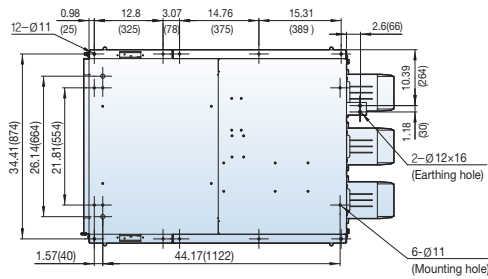
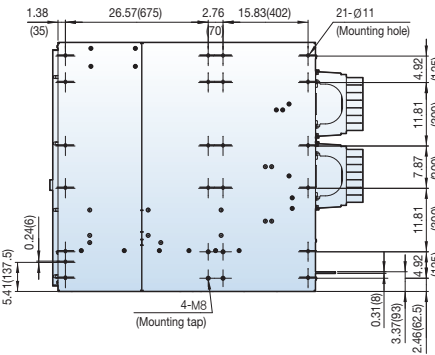
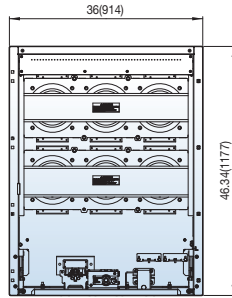
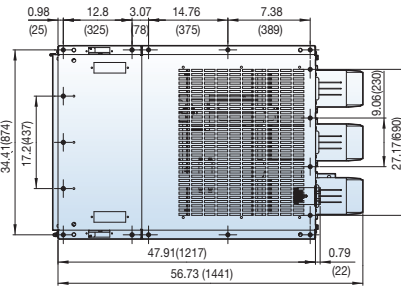
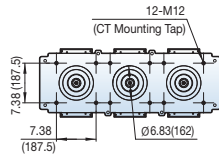

[Unit: in(mm)]

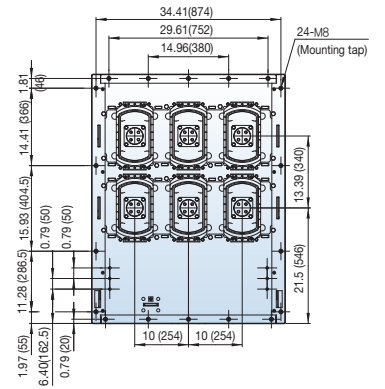
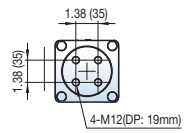
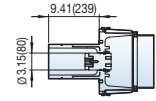

27kV, 25/31.5/40kA, 2750A

UVH type, Draw-out type

Cradle model

- UVCH-27C25C28
- UVCH-27C32C28
- UVCH-27C40C28

[Unit: in(mm)]

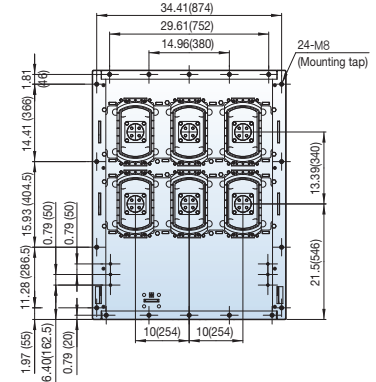
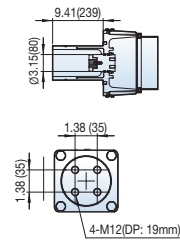
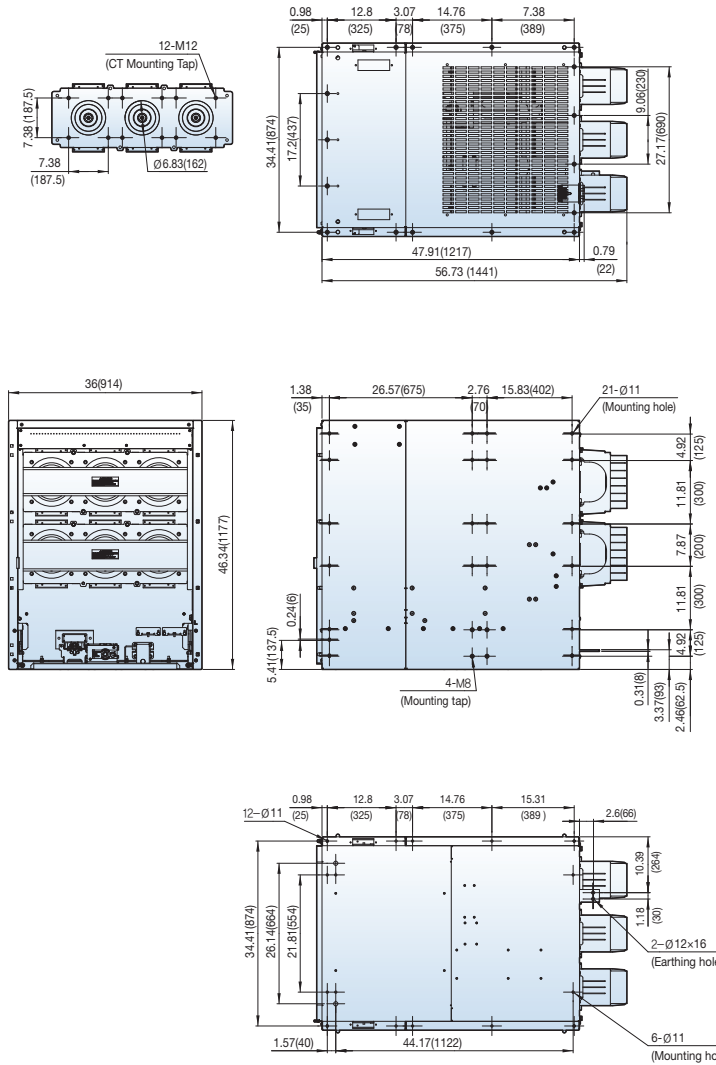

Dimensions

27kV, 31.5/40kA, 1200A

UVH type, Draw-out type

Cradle model

UVCH-27H32C12
UVCH-27H40C12

[Unit: in(mm)]

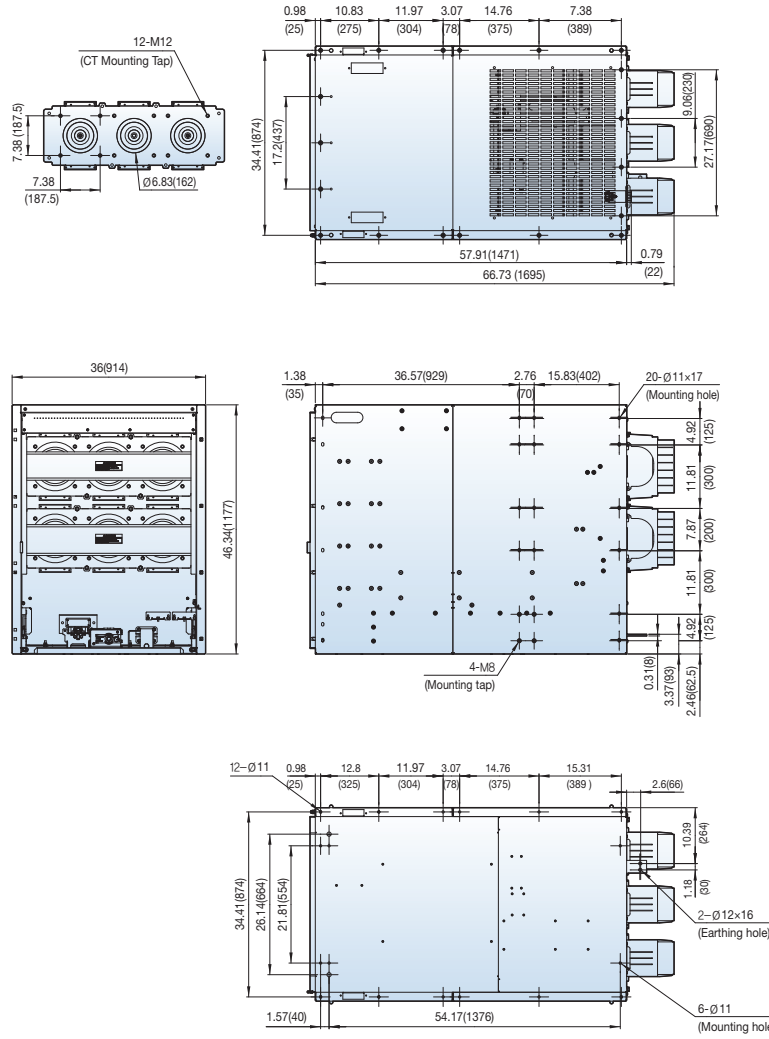

27kV, 31.5/40kA, 2000A

UVH type, Draw-out type

Cradle model

UVCH-27H32C20
UVCH-27H40C20

[Unit: in(mm)]

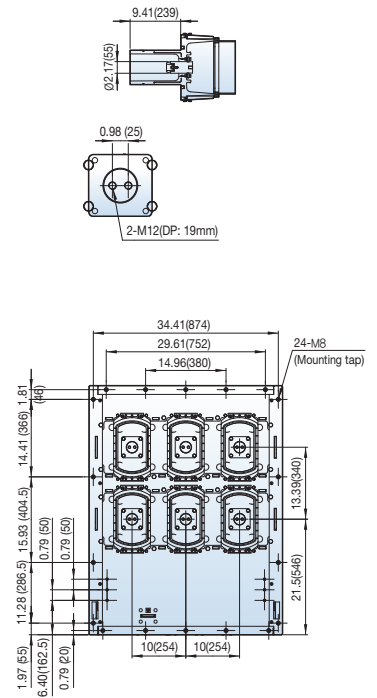
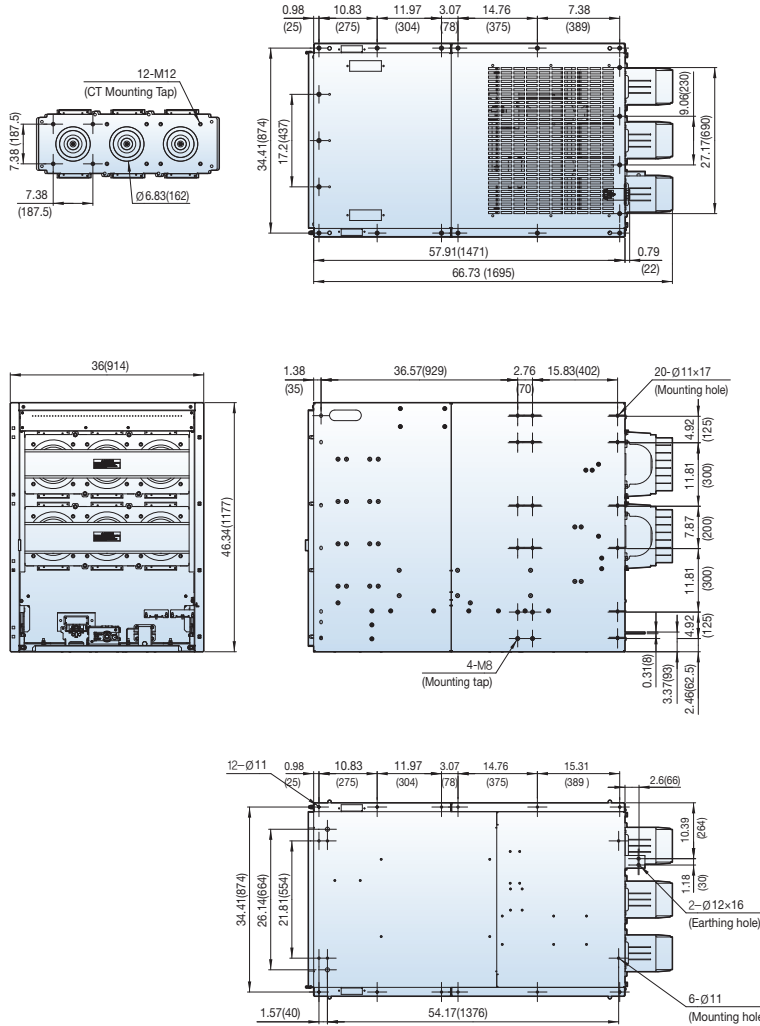

Dimensions

27kV, 25/31.5/40kA, 2500A

UVH type, Draw-out type

Cradle model

UVCH-27H25C25
 UVCH-27H32C25
 UVCH-27H40C25

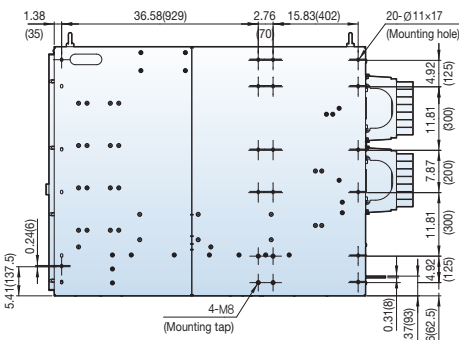
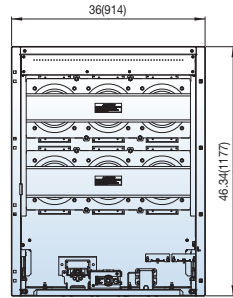
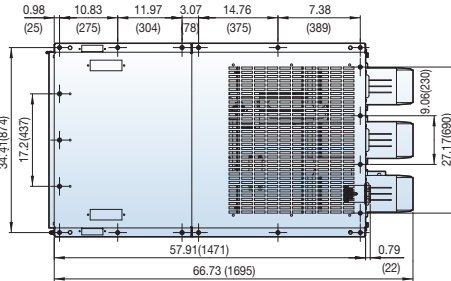
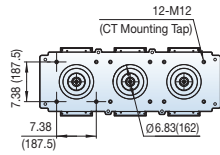

[Unit: in(mm)]

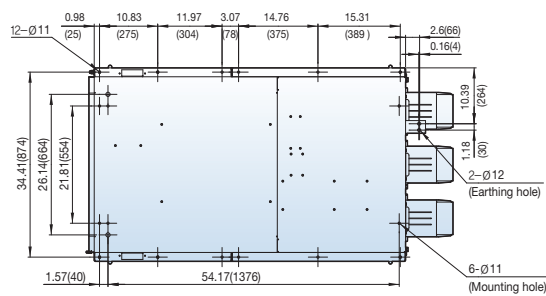
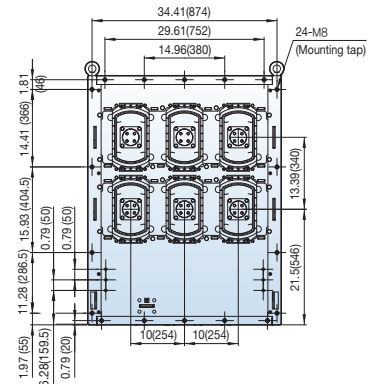
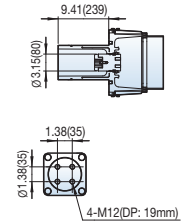

27kV, 25/31.5/40kA, 2750A

UVH type, Draw-out type

Cradle model

- UVCH-27H25C28
- UVCH-27H32C28
- UVCH-27H40C28

[Unit: in(mm)]

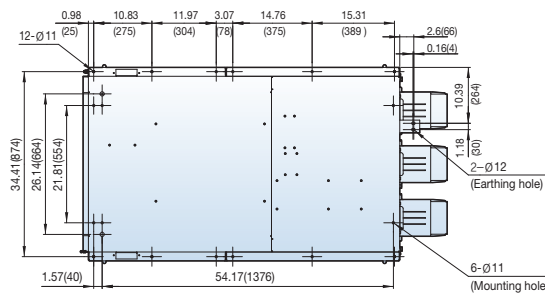
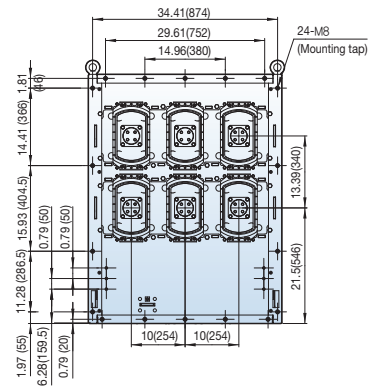
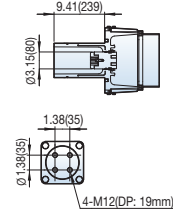
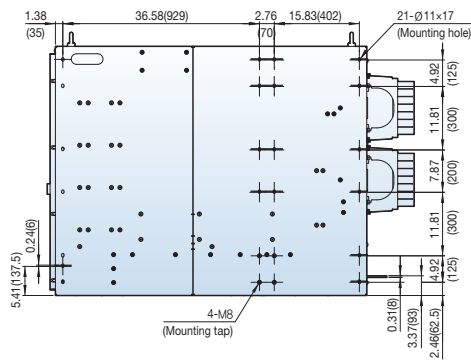
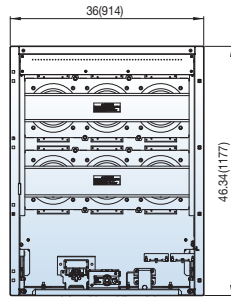
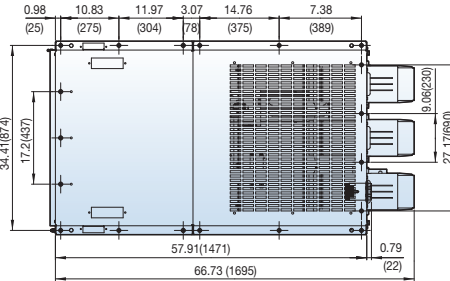
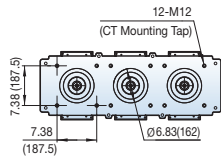

Dimensions

38kV, 31.5/40kA, 1200/2000A

UVH type, Draw-out type

Cradle model

- UVCH-38H32E12
- UVCH-38H32E20
- UVCH-38H40E12
- UVCH-38H40E20

[Unit: in(mm)]

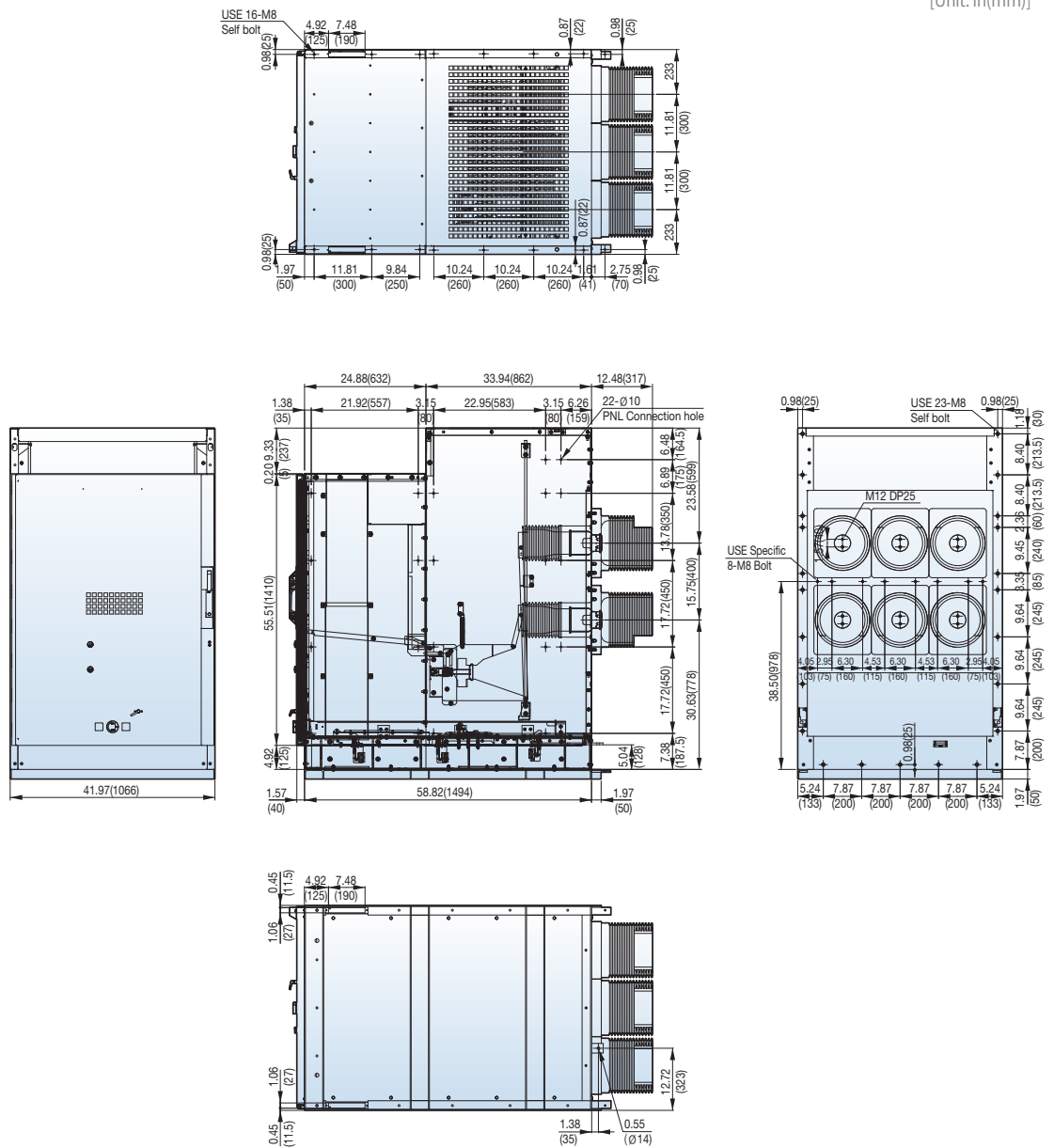

38kV, 31.5/40kA, 3000A

UVH type, Draw-out type

Cradle model

UVCH-38H32E30
UVCH-38H40E30

[Unit: in(mm)]

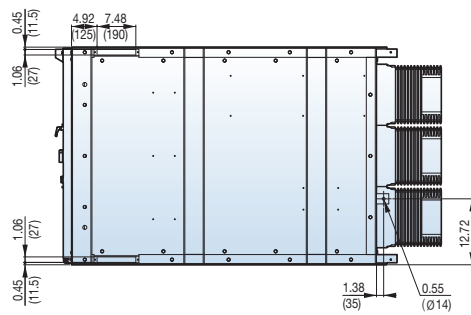
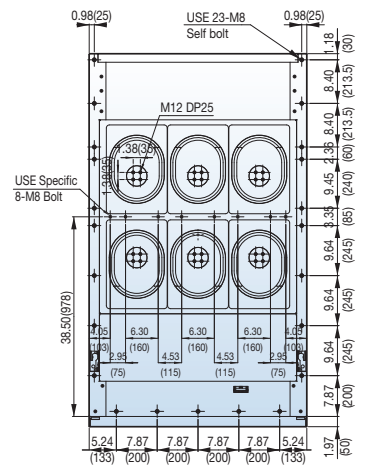
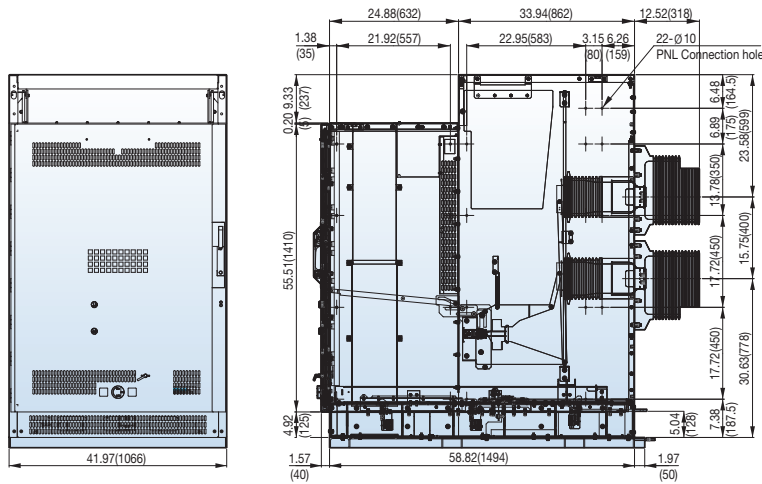
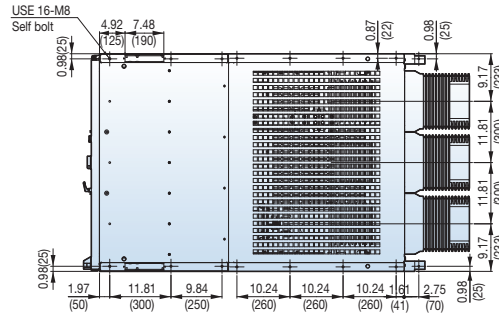

Dimensions

38kV, 31.5/40kA, 1200/2000A, DRI

UVH type, Draw-out type

Cradle model

- UVCH-38D32E12
- UVCH-38D32E20
- UVCH-38D40E12
- UVCH-38D40E20

[Unit: in(mm)]

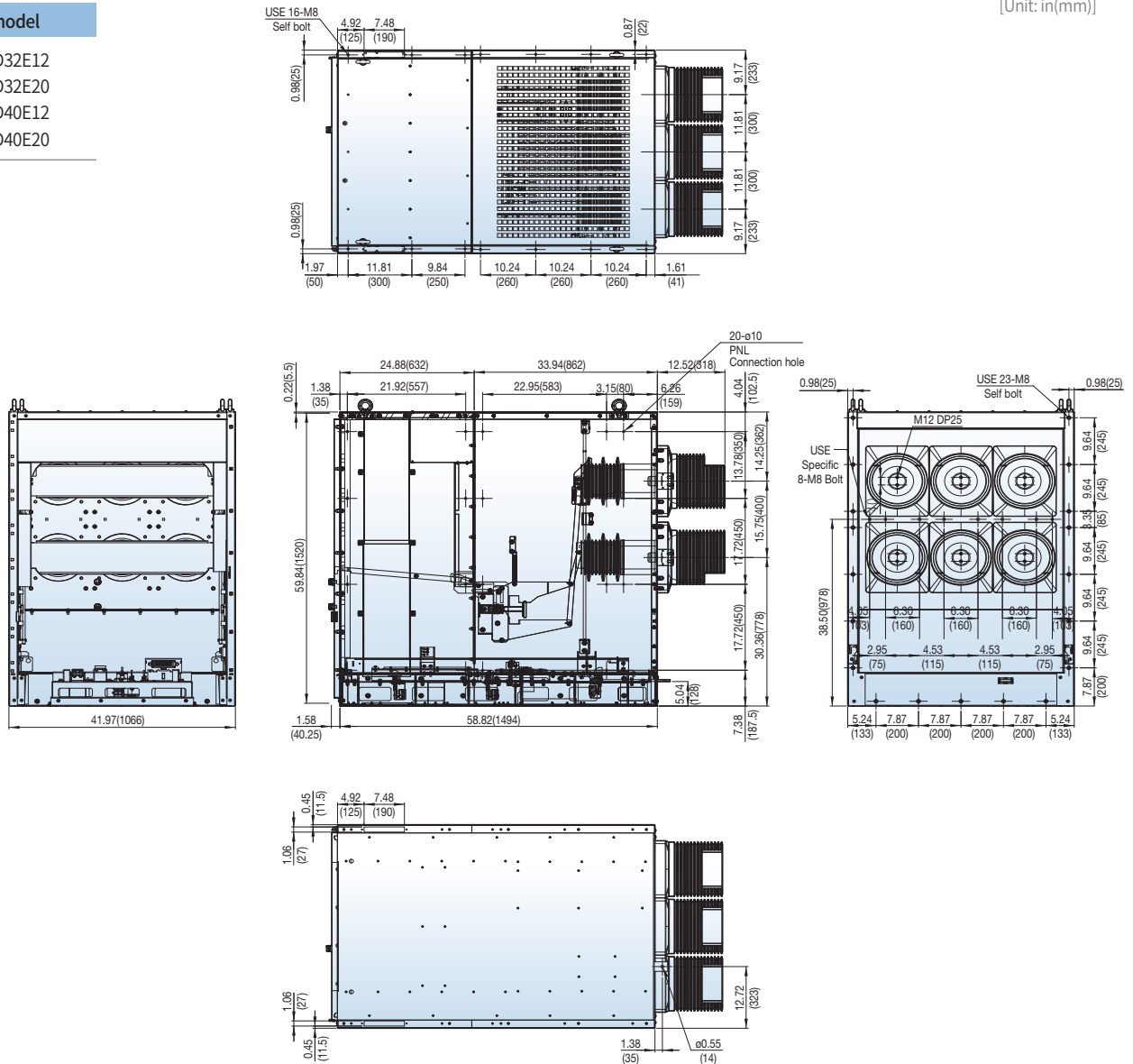

38kV, 31.5/40kA, 3000A, DRI

VH type, Draw-out type

[Unit: in(mm)]

Cradle model

UVCH-38D32E30
UVCH-38D40E30

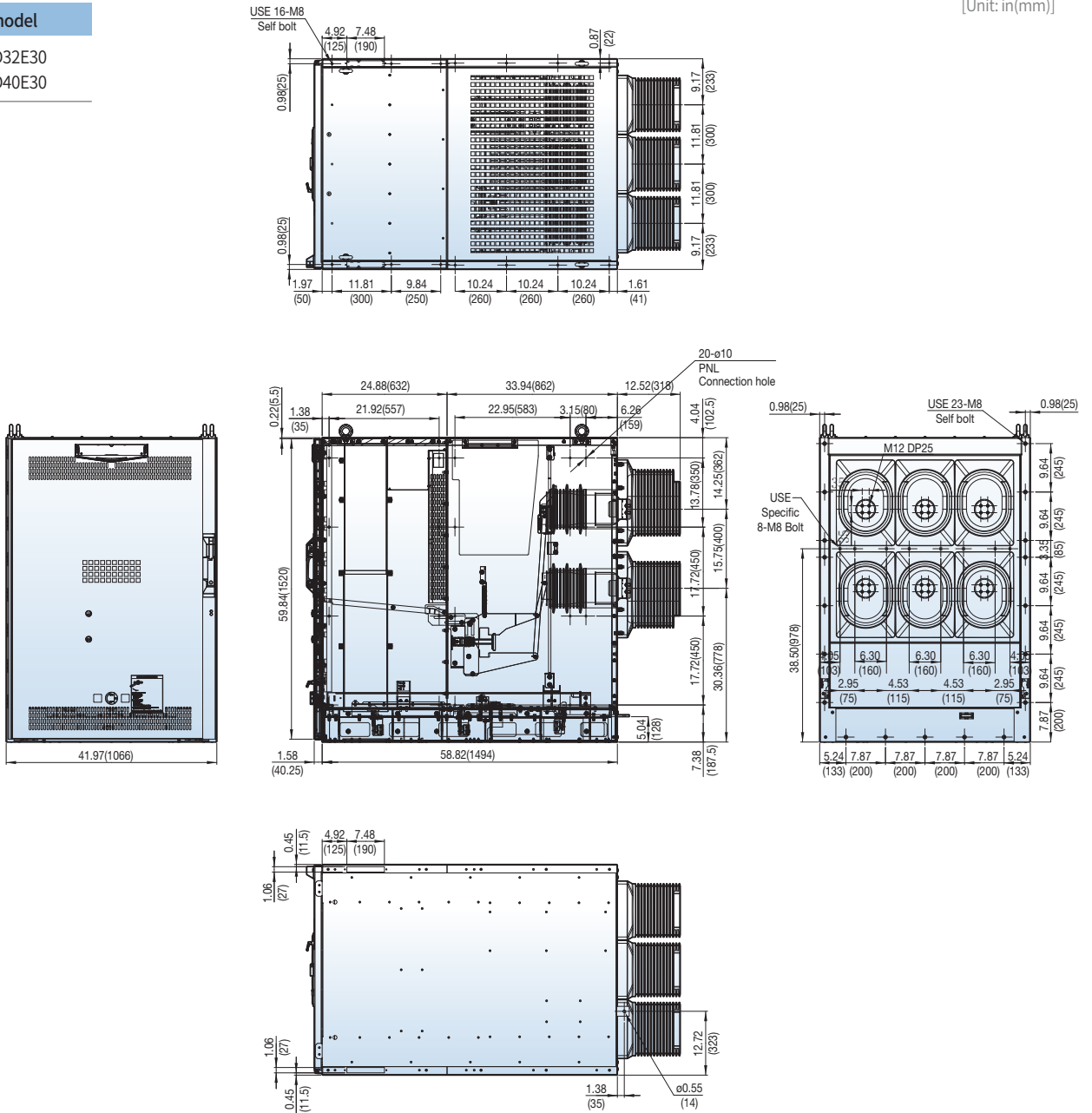

Memo

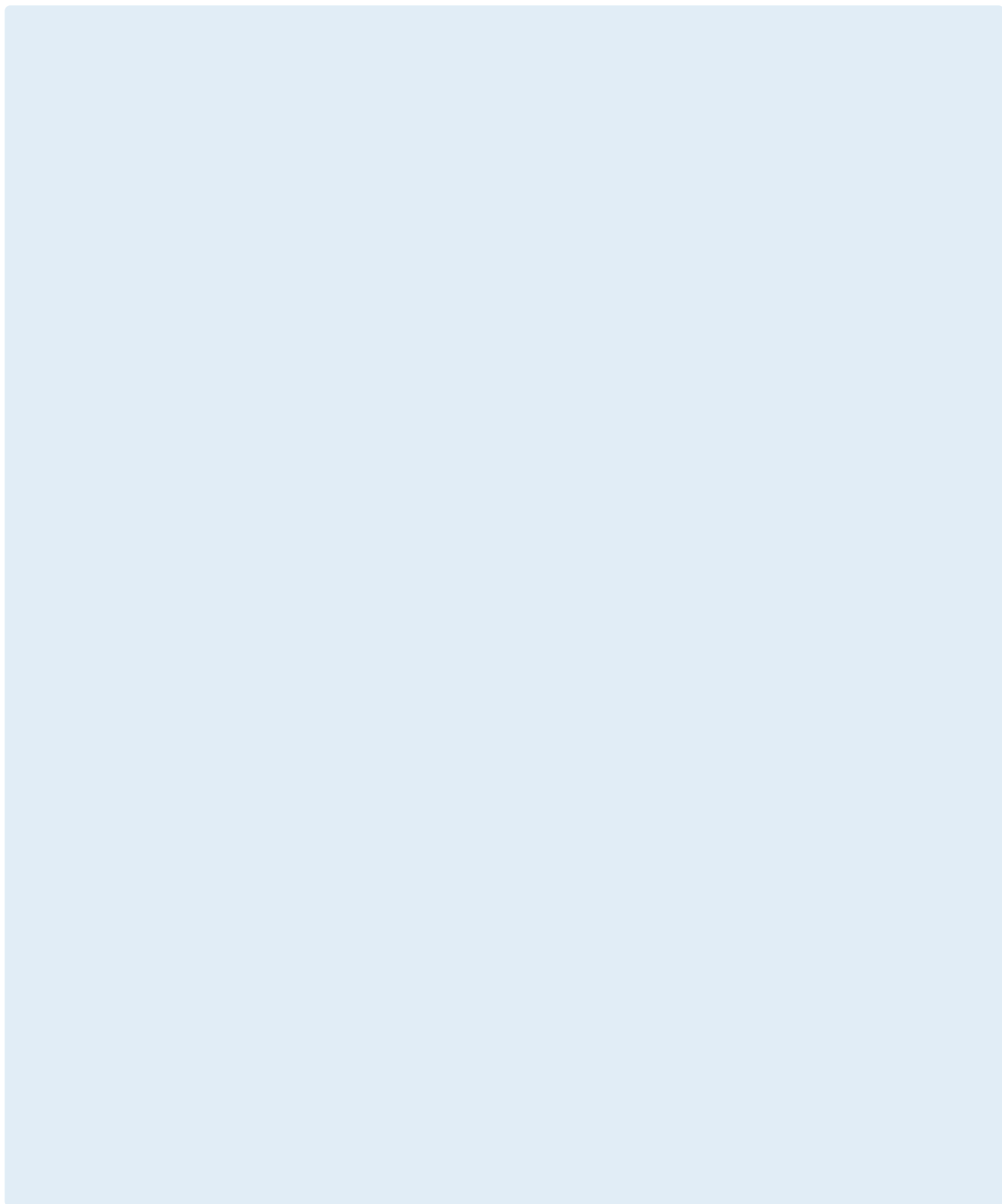

Susol UVGT

Simple Manual Device type



Contents

▪ Ratings and description	142
▪ Selection guide	143
▪ Dimensions	144

Ratings and description

UVGT, Simple manual device type

UVGT-05Ms

G&T model		UVGT-05Ms			
Rated voltage	Ur (kV)	4.76			
Rated withstand voltage	Power frequency (1min)	Ud (kV)	19		
	Lightening impulse (1.2×50µs)	Up (kV)	60		
Rated short-time withstand current	Isc (kA)	25		31.5	
Rated normal current	Ir (A)	1200	2000	1200	2000
Rated frequency	fr (Hz)	60	60	60	60
Rated momentary withstand current	Ip (kA) at 60 Hz	65	65	81.9	81.9

UVGT-15Ms

G&T model		UVGT-15Ms			
Rated voltage	Ur (kV)	15			
Rated withstand voltage	Power frequency (1min)	Ud (kV)	36		
	Lightening impulse (1.2×50µs)	Up (kV)	95		
Rated short-time withstand current	Isc (kA)	25		31.5	
Rated normal current	Ir (A)	1200	2000	1200	2000
Rated frequency	fr (Hz)	60	60	60	60
Rated momentary withstand current	Ip (kA) at 60 Hz	65	65	81.9	81.9

UVGT-38Ms

G&T model		UVGT-38Ms					
Rated voltage	Ur (kV)	38					
Rated withstand voltage	Power frequency (1min)	Ud (kV)	80				
	Lightening impulse (1.2×50µs)	Up (kV)	170				
Rated short-time withstand current	Isc (kA)	31.5			40		
Rated normal current	Ir (A)	1200	2000	3000	1200	2000	3000
Rated frequency	fr (Hz)	60	60	60	60	60	60
Rated momentary withstand current	Ip (kA) at 60 Hz	81.9	81.9	81.9	104	104	104

Description for ground and test device type

UVGT type

UVGT		15	Ms	32	A	12	
Model	Rated voltage (kV)	Type	Rated short-time withstand current (kA)	Phase distance	Rated current (A)		
UVGT Ground and Test Device	05	4.76	Ms Simple manual	25	R 5.9in(150mm)	12	1200
	15	15		32		31.5	20
	38	38	Ms Simple manual	32	E 11.8in(300mm)	12	1200
				40		20	2000
						30	3000

Selection table of ground and test devices

Upper and Lower terminals

G&T model	Related VCB	Outline dimension (H×W×D [in])	Ordering sales code	Dimension page
UVGT-05Ms25R12-AA	UVL-05H25R12	27.1×19.8×25.3	Contact LS ELECTRIC sales person	144
UVGT-05Ms25S12-AA	UVL-05H25S12	27.1×25.7×25.3		144
UVGT-05Ms25S20-AA	UVL-05H25B20	27.1×25.7×25.3		145
UVGT-05Ms32R12-AA	UVL-05H32R12	27.1×19.8×25.3		144
UVGT-05Ms32S12-AA	UVL-05H32S12	27.1×25.7×25.3		144
UVGT-05Ms32S20-AA	UVL-05H32B20	27.1×25.7×25.3		145
UVGT-15Ms25R12-AA	UVL-15H25R12	27.1×19.8×25.3		144
UVGT-15Ms25S12-AA	UVL-15H25S12	27.1×25.7×25.3		144
UVGT-15Ms25S20-AA	UVL-15H25B20	27.1×25.7×25.3		145
UVGT-15Ms32R12-AA	UVL-15H32R12	27.1×19.8×25.3		144
UVGT-15Ms32S12-AA	UVL-15H32S12	27.1×25.7×25.3		144
UVGT-15Ms32S20-AA	UVL-15H32B20	27.1×25.7×25.3		145
UVGT-38Ms32E12-AA	UVH-38H32E12	43.3×37.9×40.3		146
UVGT-38Ms32E20-AA	UVH-38H32E20	43.3×37.9×40.3		146
UVGT-38Ms32E30-AA	UVH-38H32E30	43.3×37.9×40.3		146
UVGT-38Ms40E12-AA	UVH-38H40E12	43.3×37.9×40.3		146
UVGT-38Ms40E20-AA	UVH-38H40E20	43.3×37.9×40.3		146
UVGT-38Ms40E30-AA	UVH-38H40E30	43.3×37.9×40.3		146

Upper terminals only

G&T model	Related VCB	Outline dimension (H×W×D [in])	Ordering sales code	Dimension page
UVGT-05Ms25R12-AB	UVL-05H25R12	27.1×19.8×25.3	Contact LS ELECTRIC sales person	144
UVGT-05Ms25S12-AB	UVL-05H25S12	27.1×25.7×25.3		144
UVGT-05Ms25S20-AB	UVL-05H25B20	27.1×25.7×25.3		145
UVGT-05Ms32R12-AB	UVL-05H32R12	27.1×19.8×25.3		144
UVGT-05Ms32S12-AB	UVL-05H32S12	27.1×25.7×25.3		144
UVGT-05Ms32S20-AB	UVL-05H32B20	27.1×25.7×25.3		145
UVGT-15Ms25R12-AB	UVL-15H25R12	27.1×19.8×25.3		144
UVGT-15Ms25S12-AB	UVL-15H25S12	27.1×25.7×25.3		144
UVGT-15Ms25S20-AB	UVL-15H25B20	27.1×25.7×25.3		145
UVGT-15Ms32R12-AB	UVL-15H32R12	27.1×19.8×25.3		144
UVGT-15Ms32S12-AB	UVL-15H32S12	27.1×25.7×25.3		144
UVGT-15Ms32S20-AB	UVL-15H32B20	27.1×25.7×25.3		145
UVGT-38Ms32E12-AB	UVH-38H32E12	43.3×37.9×40.3		146
UVGT-38Ms32E20-AB	UVH-38H32E20	43.3×37.9×40.3		146
UVGT-38Ms32E30-AB	UVH-38H32E30	43.3×37.9×40.3		146
UVGT-38Ms40E12-AB	UVH-38H40E12	43.3×37.9×40.3		146
UVGT-38Ms40E20-AB	UVH-38H40E20	43.3×37.9×40.3		146
UVGT-38Ms40E30-AB	UVH-38H40E30	43.3×37.9×40.3		146

Lower terminals only

G&T model	Related VCB	Outline dimension (H×W×D [in])	Ordering sales code	Dimension page
UVGT-05Ms25R12-AC	UVL-05H25R12	27.1×19.8×25.3	Contact LS ELECTRIC sales person	144
UVGT-05Ms25S12-AC	UVL-05H25S12	27.1×25.7×25.3		144
UVGT-05Ms25S20-AC	UVL-05H25B20	27.1×25.7×25.3		145
UVGT-05Ms32R12-AC	UVL-05H32R12	27.1×19.8×25.3		144
UVGT-05Ms32S12-AC	UVL-05H32S12	27.1×25.7×25.3		144
UVGT-05Ms32S20-AC	UVL-05H32B20	27.1×25.7×25.3		145
UVGT-15Ms25R12-AC	UVL-15H25R12	27.1×19.8×25.3		144
UVGT-15Ms25S12-AC	UVL-15H25S12	27.1×25.7×25.3		144
UVGT-15Ms25S20-AC	UVL-15H25B20	27.1×25.7×25.3		145
UVGT-15Ms32R12-AC	UVL-15H32R12	27.1×19.8×25.3		144
UVGT-15Ms32S12-AC	UVL-15H32S12	27.1×25.7×25.3		144
UVGT-15Ms32S20-AC	UVL-15H32B20	27.1×25.7×25.3		145
UVGT-38Ms32E12-AC	UVH-38H32E12	43.3×37.9×40.3		146
UVGT-38Ms32E20-AC	UVH-38H32E20	43.3×37.9×40.3		146
UVGT-38Ms32E30-AC	UVH-38H32E30	43.3×37.9×40.3		146
UVGT-38Ms40E12-AC	UVH-38H40E12	43.3×37.9×40.3		146
UVGT-38Ms40E20-AC	UVH-38H40E20	43.3×37.9×40.3		146
UVGT-38Ms40E30-AC	UVH-38H40E30	43.3×37.9×40.3		146

Dimensions

4.76/15kV 25/31.5kA 1200A

UVGT type, Draw-out type

[Unit: in(mm)]

Ground and test device model

UVGT-05Ms25R12
 UVGT-05Ms32R12
 UVGT-15Ms25R12
 UVGT-15Ms32R12

Related VCB

UVL-05H25R12
 UVL-05H32R12
 UVL-15H25R12
 UVL-15H32R12

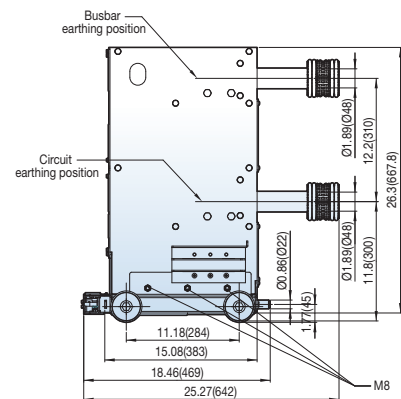
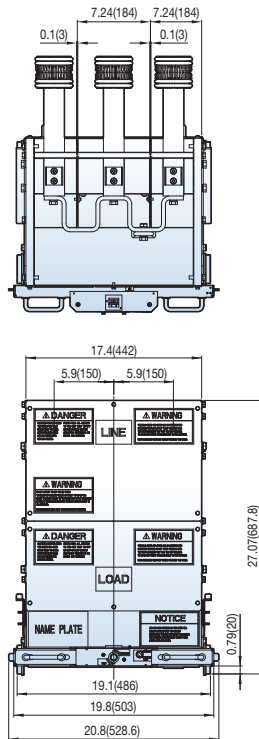

Ground and test device model

UVGT-05Ms25S12
 UVGT-05Ms32S12
 UVGT-15Ms25S12
 UVGT-15Ms32S12

Related VCB

UVL-05H25S12
 UVL-05H32S12
 UVL-15H25S12
 UVL-15H32S12

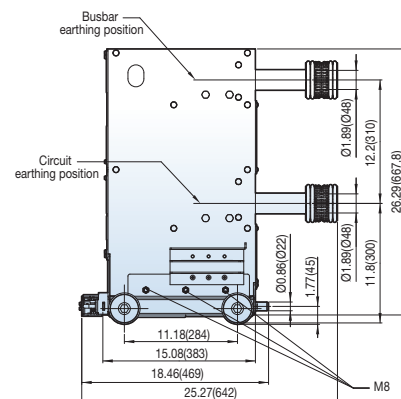
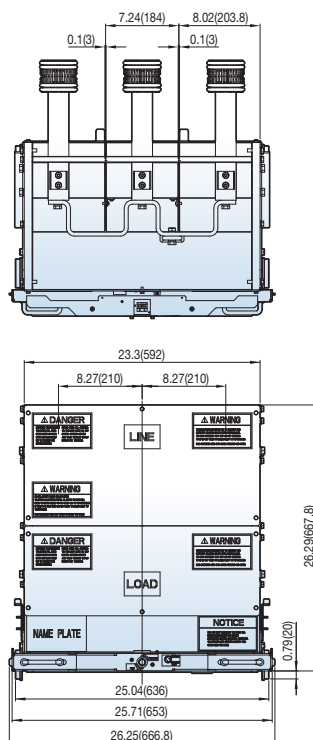

4.76/15kV 25/31.5kA 2000A

UVGT type, Draw-out type

Ground and test device model

- UVGT-05Ms25S20
- UVGT-05Ms32S20
- UVGT-15Ms25S20
- UVGT-15Ms32S20

Related VCB

- UVL-05H25B20
- UVL-05H32B20
- UVL-15H25B20
- UVL-15H32B20

[Unit: in(mm)]

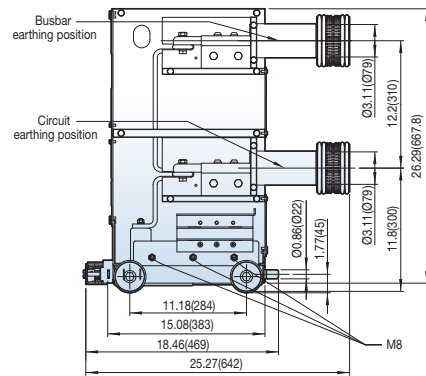
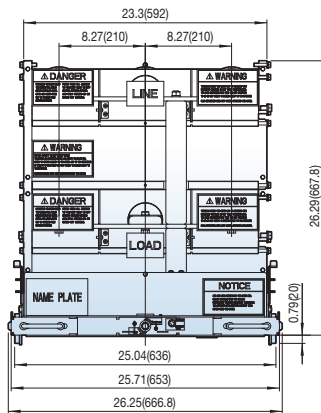
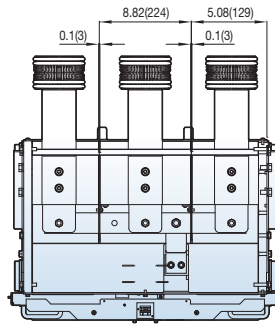

Dimensions

38kV 31.5/40kA 1200/2000A

UVGT type, Draw-out type

Ground and test device model

- UVGT-38Ms32E12
- UVGT-38Ms32E20
- UVGT-38Ms40E12
- UVGT-38Ms40E20

Related VCB

- UVH-38H32E12
- UVH-38H32E20
- UVH-38H40E12
- UVH-38H40E20

[Unit: in(mm)]

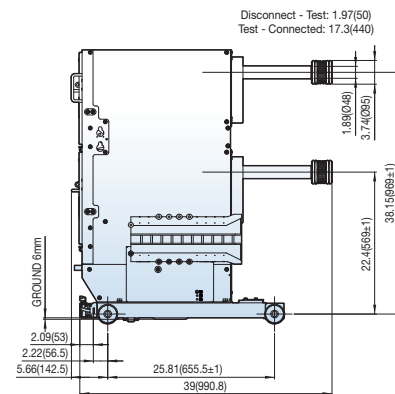
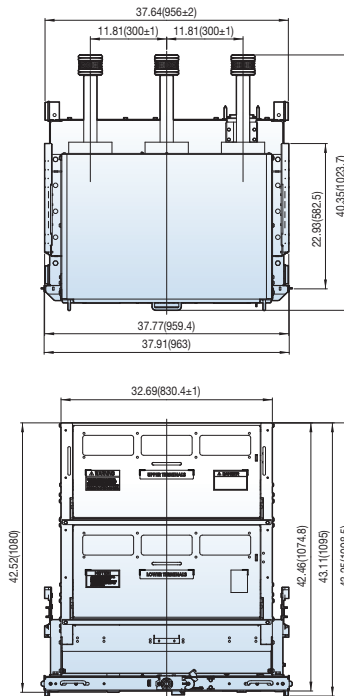

38kV 31.5/40kA 3000A

Ground and test device model

- UVGT-38Ms32E30
- UVGT-38Ms40E30

Related VCB

- UVH-38H32E30
- UVH-38H40E30

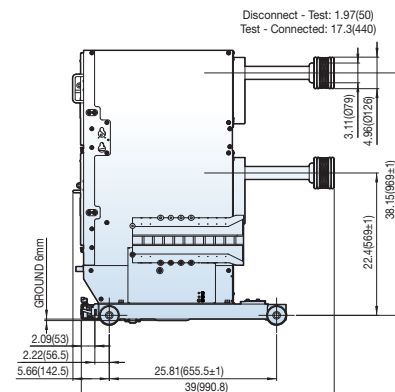
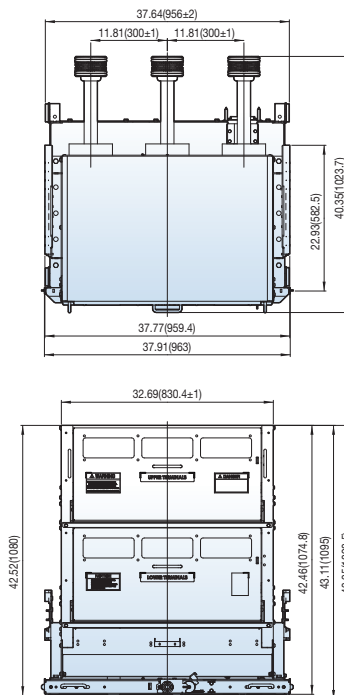

Susol UCGT

Simple Manual Device type



Contents

▪ Ratings and description	148
▪ Selection guide	150
▪ Dimensions	153

Ratings and description

UCGT, Simple manual device type

UCGT-05Ms

G&T model		UCGT-05Ms															
Rated voltage	Ur (kV)	4.76															
Rated withstand voltage	Power frequency (1min)	Ud (kV) 19															
	Lightening impulse (1.2×50µs)	Up (kV) 60															
Rated short-time withstand current	Isc (kA)	25	31.5				40				50						
Rated normal current	Ir (A)	1200	2000	3000	4000	1200	2000	3000	4000	1200	2000	3000	4000	1200	2000	3000	4000
Rated frequency	fr (Hz)	60	60	60	60	60	60	60	60	60	60	60	60	60	60	60	60
Rated momentary withstand current	Ip (kA) at 60 Hz	65	65	65	65	81.9	81.9	81.9	81.9	104	104	104	104	130	130	130	130

UCGT-15Ms

G&T model		UCGT-15Ms															
Rated voltage	Ur (kV)	15															
Rated withstand voltage	Power frequency (1min)	Ud (kV) 36															
	Lightening impulse (1.2×50µs)	Up (kV) 95															
Rated short-time withstand current	Isc (kA)	25	31.5				40				50						
Rated normal current	Ir (A)	1200	2000	3000	4000	1200	2000	3000	4000	1200	2000	3000	4000	1200	2000	3000	4000
Rated frequency	fr (Hz)	60	60	60	60	60	60	60	60	60	60	60	60	60	60	60	60
Rated momentary withstand current	Ip (kA) at 60 Hz	65	65	65	65	81.9	81.9	81.9	81.9	104	104	104	104	130	130	130	130

UCGT-27Ms

G&T model		UCGT-27Ms															
Rated voltage	Ur (kV)	27															
Rated withstand voltage	Power frequency (1min)	Ud (kV) 60															
	Lightening impulse (1.2×50µs)	Up (kV) 125															
Rated short-time withstand current	Isc (kA)	25	31.5				40										
Rated normal current	Ir (A)	1200	2000	250	2750	1200	2000	250	2750	1200	2000	250	2750	1200	2000	250	2750
Rated frequency	fr (Hz)	60	60	60	60	60	60	60	60	60	60	60	60	60	60	60	60
Rated momentary withstand current	Ip (kA) at 60 Hz	65	65	65	65	81.9	81.9	81.9	81.9	104	104	104	104	104	104	104	104

Description for ground and test device type

UCGT type

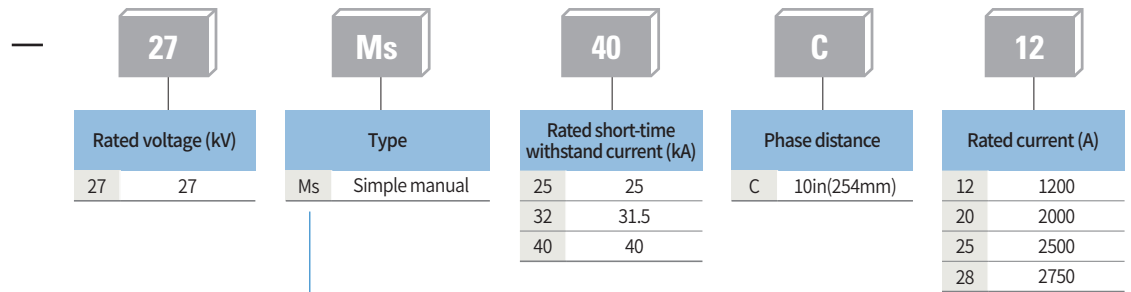
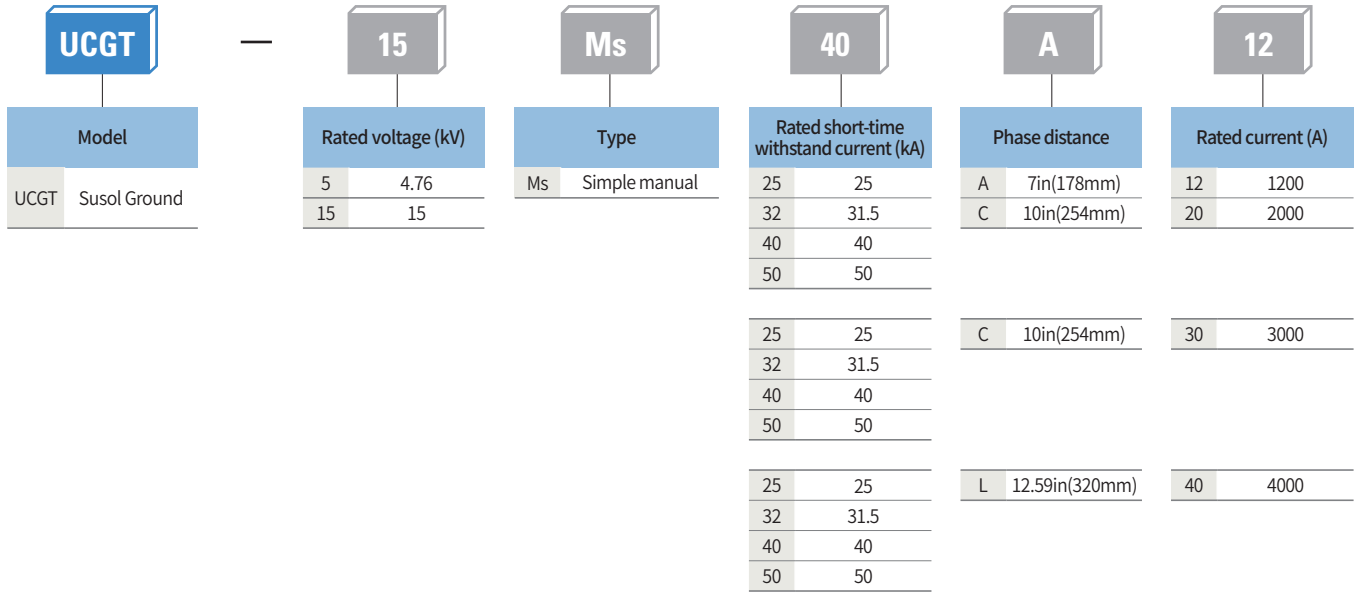

① Type of cradle
(select from the next pages)

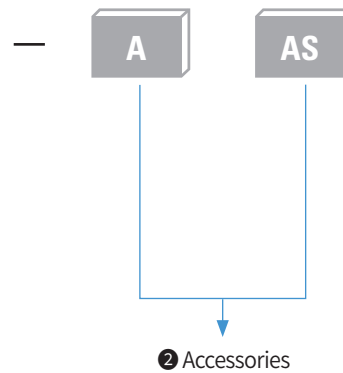

Selection guide

Selection table of ground and test devices

Upper and lower terminals

Ur [kV]	Isc [kA]	Ir [A]			G&T model □ = [A, B, C, AS, BS, CS]	Outline dimension H×W×D [in] □ = A, B, C	Outline dimension H×W×D [in] □ = AS, BS, CS	Dimension page
		p = 7"	p = 10"	p = 12.59"				
4.76	25	1200			UCGT-05Ms25A12-A□□	26.7×22×28.9	30.4×22×28.9	153
					UCGT-05Ms25A20-A□□	26.7×22×28.9	30.4×22×28.9	154
		2000			UCGT-05Ms25C12-A□□	26.7×32×28.9	30.4×32×28.9	153
					UCGT-05Ms25C20-A□□	26.7×32×28.9	30.4×32×28.9	154
					UCGT-05Ms25C30-A□□	31.7×32×28.9	35.4×32×28.9	158
		4000			UCGT-05Ms25L40-A□□	39.5×41.1×28.6	43.4×41.1×28.6	158
	31.5	1200			UCGT-05Ms32A12-A□□	26.3×22×28.9	30.4×22×28.9	153
					UCGT-05Ms32A20-A□□	26.3×22×28.9	30.4×22×28.9	154
		2000			UCGT-05Ms32C12-A□□	26.7×32×28.9	30.4×32×28.9	153
					UCGT-05Ms32C20-A□□	26.7×32×28.9	30.4×32×28.9	154
					UCGT-05Ms32C30-A□□	31.7×32×28.9	35.4×32×28.9	158
		4000			UCGT-05Ms32L40-A□□	39.5×41.1×28.6	43.4×41.1×28.6	158
	40	1200			UCGT-05Ms40A12-A□□	31.7×22×28.9	35.4×22×28.9	155
					UCGT-05Ms40A20-A□□	31.7×22×28.9	35.4×22×28.9	157
		2000			UCGT-05Ms40C12-A□□	31.7×32×28.9	35.4×32×28.9	155
					UCGT-05Ms40C20-A□□	31.7×32×28.9	35.4×32×28.9	157
					UCGT-05Ms40C30-A□□	31.7×32×28.9	35.4×32×28.9	158
		4000			UCGT-05Ms40L40-A□□	39.5×41.1×28.6	43.4×41.1×28.6	158
50	1200			UCGT-05Ms50A12-A□□	31.7×22×28.9	35.4×22×28.9	156	
				UCGT-05Ms50A20-A□□	31.7×22×28.9	35.4×22×28.9	157	
	2000			UCGT-05Ms50C12-A□□	31.7×32×28.9	35.4×32×28.9	156	
				UCGT-05Ms50C20-A□□	31.7×32×28.9	35.4×32×28.9	157	
				UCGT-05Ms50C30-A□□	31.7×32×28.9	35.4×32×28.9	158	
	4000			UCGT-05Ms50L40-A□□	39.5×41.1×28.6	43.4×41.1×28.6	158	

Upper and lower terminals

Ur [kV]	Isc [kA]	Ir [A]			G&T model □ = [A, B, C, AS, BS, CS]	Outline dimension H×W×D [in] □ = A, B, C	Outline dimension H×W×D [in] □ = AS, BS, CS	Dimension page
		p = 7"	p = 10"	p = 12.59"				
15	25	1200	2000		UCGT-15Ms25A12-A□□	26.7×22×28.9	30.4×22×28.9	153
					UCGT-15Ms25A20-A□□	26.7×22×28.9	30.4×22×28.9	154
		1200	2000	3000	UCGT-15Ms25C12-A□□	26.7×32×28.9	30.4×32×28.9	153
					UCGT-15Ms25C20-A□□	26.7×32×28.9	30.4×32×28.9	154
	UCGT-15Ms25C30-A□□				31.7×32×28.9	35.4×32×28.9	158	
	4000			UCGT-15Ms25L40-A□□	39.5×41.1×28.6	43.4×41.1×28.6	158	
		1200	2000		UCGT-15Ms32A12-A□□	26.3×22×28.9	30.4×22×28.9	153
				UCGT-15Ms32A20-A□□	26.3×22×28.9	30.4×22×28.9	154	
	1200	2000	3000	UCGT-15Ms32C12-A□□	26.7×32×28.9	30.4×32×28.9	153	
				UCGT-15Ms32C20-A□□	26.7×32×28.9	30.4×32×28.9	154	
				UCGT-15Ms32C30-A□□	31.7×32×28.9	35.4×32×28.9	158	
	4000			UCGT-15Ms32L40-A□□	39.5×41.1×28.6	43.4×41.1×28.6	158	
		1200	2000		UCGT-15Ms40A12-A□□	31.7×22×28.9	35.4×22×28.9	155
				UCGT-15Ms40A20-A□□	31.7×22×28.9	35.4×22×28.9	157	
	1200	2000	3000	UCGT-15Ms40C12-A□□	31.7×32×28.9	35.4×32×28.9	155	
				UCGT-15Ms40C20-A□□	31.7×32×28.9	35.4×32×28.9	157	
				UCGT-15Ms40C30-A□□	31.7×32×28.9	35.4×32×28.9	158	
	4000			UCGT-15Ms40L40-A□□	39.5×41.1×28.6	43.4×41.1×28.6	158	
		1200	2000		UCGT-15Ms50A12-A□□	31.7×22×28.9	35.4×22×28.9	156
				UCGT-15Ms50A20-A□□	31.7×22×28.9	35.4×22×28.9	157	
1200	2000	3000	UCGT-15Ms50C12-A□□	31.7×32×28.9	35.4×32×28.9	156		
			UCGT-15Ms50C20-A□□	31.7×32×28.9	35.4×32×28.9	157		
			UCGT-15Ms50C30-A□□	31.7×32×28.9	35.4×32×28.9	158		
4000			UCGT-15Ms50L40-A□□	39.5×41.1×28.6	43.4×41.1×28.6	158		
	25	2000	2500	2750	UCGT-27Ms25C12-A□□	33.8×32×30.9	37.5×32×30.9	159
					UCGT-27Ms25C20-A□□	33.8×32×30.9	37.5×32×30.9	159
UCGT-27Ms25C25-A□□					36.6×32×34.8	40.4×32×34.8	161	
UCGT-27Ms25C28-A□□					36.6×32×34.8	40.4×32×34.8	161	
1200	2000	2500	2750	UCGT-27Ms32C12-A□□	36.6×32×34.8	40.4×32×34.8	160	
				UCGT-27Ms32C20-A□□	36.6×32×34.8	40.4×32×34.8	160	
				UCGT-27Ms32C25-A□□	36.6×32×34.8	40.4×32×34.8	161	
				UCGT-27Ms32C28-A□□	36.6×32×34.8	40.4×32×34.8	161	
1200	2000	2500	2750	UCGT-27Ms40C12-A□□	36.6×32×34.8	40.4×32×34.8	160	
				UCGT-27Ms40C20-A□□	36.6×32×34.8	40.4×32×34.8	160	
				UCGT-27Ms40C25-A□□	36.6×32×34.8	40.4×32×34.8	161	
				UCGT-27Ms40C28-A□□	36.6×32×34.8	40.4×32×34.8	161	

Ratings and description

UCGT-05Ms25A12



① Type of Ground and Test device
(Select from the previous page)



② Accessories

Order form for ground & test device (UCGT)

Please select only one item per line. (*Required selection)

UCGT, Ground & Test Device, Draw-out type

(no extra charge extra charge)

① Type of Ground and Test device from selection table*		Quantity	ea
② Accessories			
Terminal set*			
<input type="checkbox"/> AA (Upper and Lower terminals)	<input type="checkbox"/> AB (Upper terminals only)	<input type="checkbox"/> AC (Lower terminals only)	
Auxiliary wheels (Direct Roll-in)			page 177
<input type="checkbox"/> AS			

4.76/15kV, 25/31.5kA, 1200A

UCGT type, Draw-out type

Ground and test device model

- UCGT-05Ms25A12
- UCGT-05Ms32A12
- UCGT-15Ms25A12
- UCGT-15Ms32A12

Related VCB

- UVM-05H25A12
- UVM-05H32A12
- UVM-15H25A12
- UVM-15H32A12

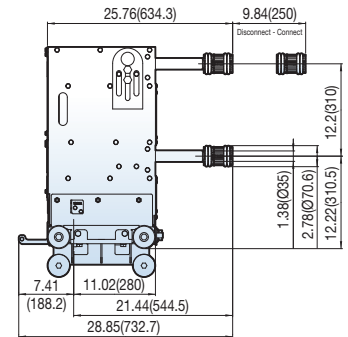
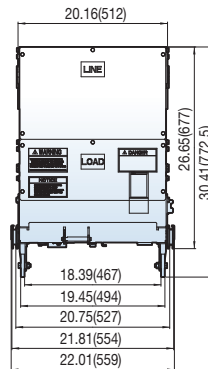
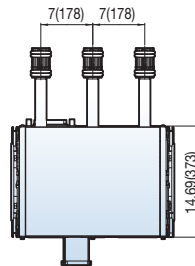

[Unit: in(mm)]

Ground and test device model

- UCGT-05Ms25C12
- UCGT-05Ms32C12
- UCGT-15Ms25C12
- UCGT-15Ms32C12

Related VCB

- UVM-05H25C12
- UVM-05H32C12
- UVM-15H25C12
- UVM-15H32C12

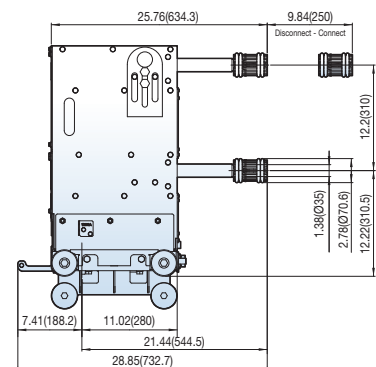
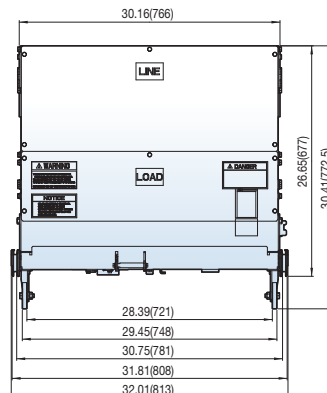
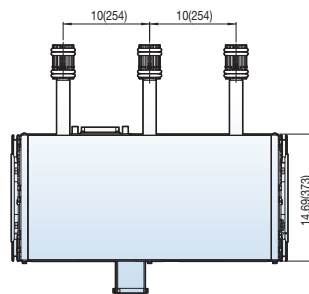

Dimensions

4.76/15kV, 25/31.5kA, 2000A

UCGT type, Draw-out type

Ground and test device model

UCGT-05Ms25A20
UCGT-05Ms32A20
UCGT-15Ms25A20
UCGT-15Ms32A20

Related VCB

UVM-05H25A20
UVM-05H32A20
UVM-15H25A20
UVM-15H32A20

[Unit: in(mm)]

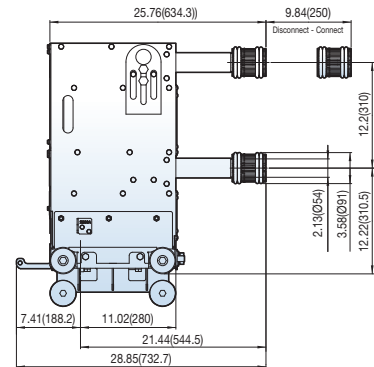
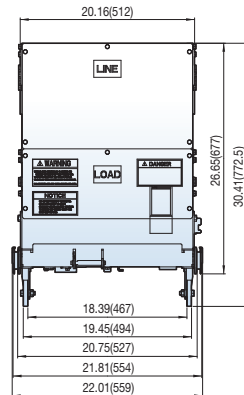
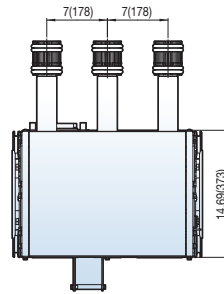

Ground and test device model

UCGT-05Ms25C20
UCGT-05Ms32C20
UCGT-15Ms25C20
UCGT-15Ms32C20

Related VCB

UVM-05H25C20
UVM-05H32C20
UVM-15H25C20
UVM-15H32C20

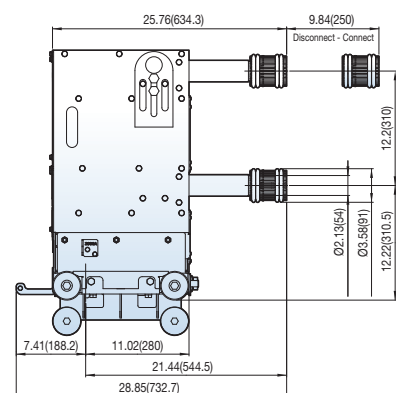
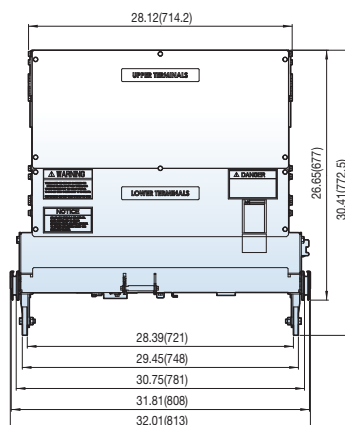
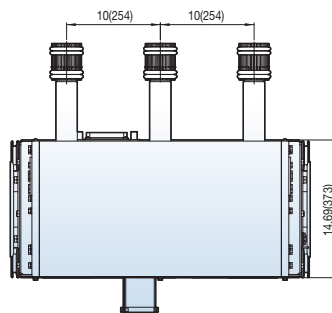

4.76/15kV, 40kA, 1200A

UCGT type, Draw-out type

Ground and test device model

UCGT-05Ms40A12
UCGT-15Ms40A12

Related VCB

UVH-05H40A12
UVH-15H40A12

[Unit: in(mm)]

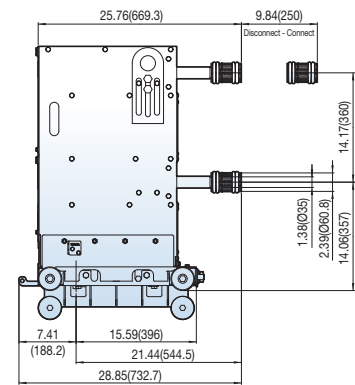
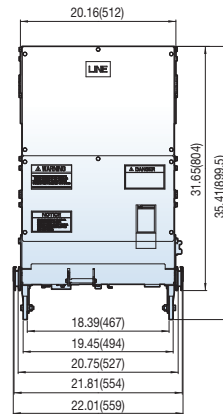
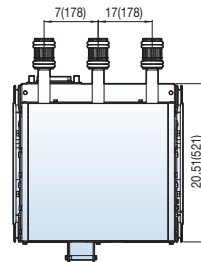

Ground and test device model

UCGT-05Ms40C12
UCGT-15Ms40C12

Related VCB

UVH-05H40C12
UVH-15H40C12

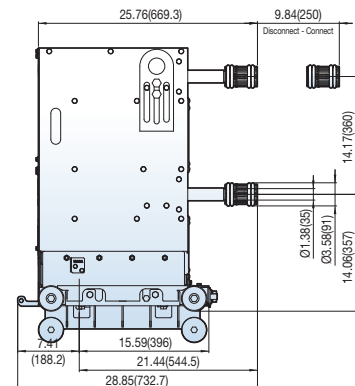
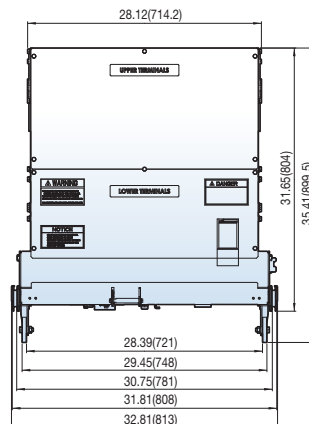
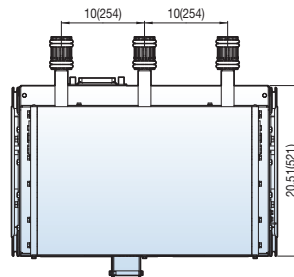

Dimensions

4.76/15kV, 50kA, 1200A

UCGT type, Draw-out type

Ground and test device model

UCGT-05Ms50A12
UCGT-15Ms50A12

Related VCB

UVH-05H50A12
UVH-15H50A12

[Unit: in(mm)]

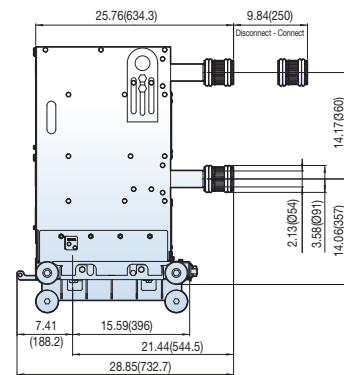
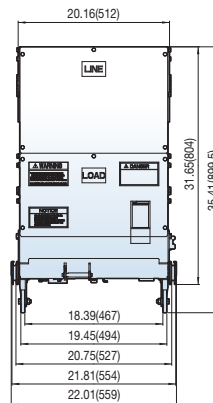
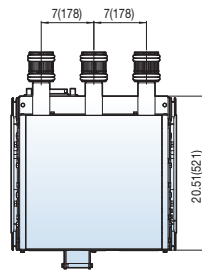

Ground and test device model

UCGT-05Ms50C12
UCGT-15Ms50C12

Related VCB

UVH-05H50C12
UVH-15H50C12

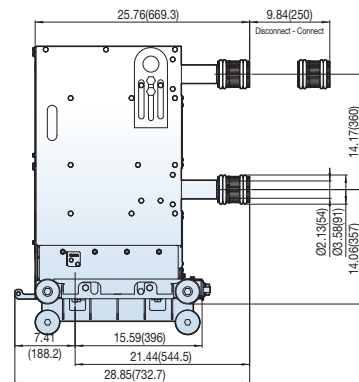
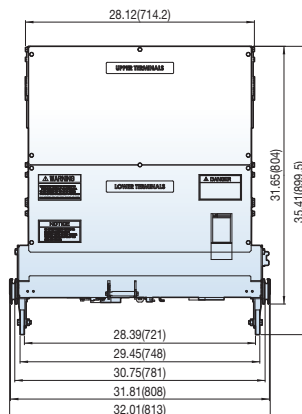
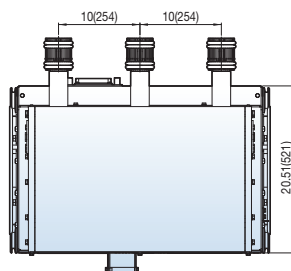

4.76/15kV, 40/50kA, 2000A

UCGT type, Draw-out type

[Unit: in(mm)]

Ground and test device model

- UCGT-05Ms40A20
- UCGT-05Ms50A20
- UCGT-15Ms40A20
- UCGT-15Ms50A20

Related VCB

- UVH-05H40A20
- UVH-05H50A20
- UVH-15H40A20
- UVH-15H50A20

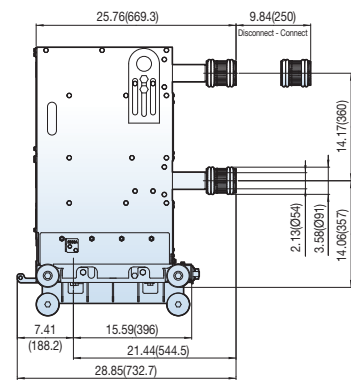
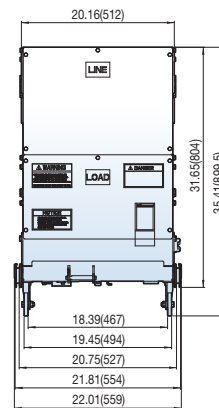
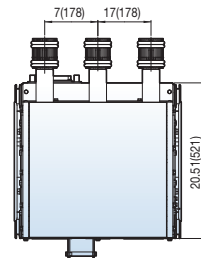

Ground and test device model

- UCGT-05Ms40C20
- UCGT-05Ms50C20
- UCGT-15Ms40C20
- UCGT-15Ms50C20

Related VCB

- UVH-05H40C20
- UVH-05H50C20
- UVH-15H40C20
- UVH-15H50C20

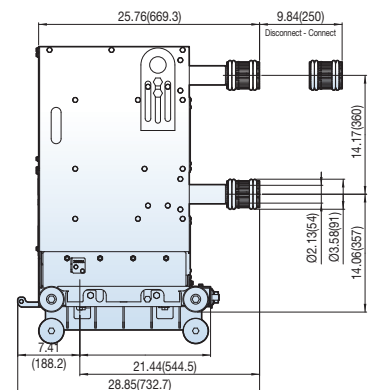
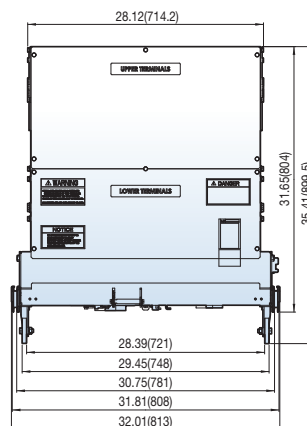
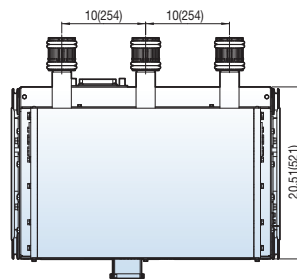

Dimensions

4.76/15kV, 25/31.5/40/50kA, 3000A

UCGT type, Draw-out type

Ground and test device model

UCGT-05Ms25C30
 UCGT-05Ms32C30
 UCGT-05Ms40C30
 UCGT-05Ms50C30
 UCGT-15Ms25C30
 UCGT-15Ms32C30
 UCGT-15Ms40C30
 UCGT-15Ms50C30

Related VCB

UVH-05H25C30
 UVH-05H32C30
 UVH-05H40C30
 UVH-05H50C30
 UVH-15H25C30
 UVH-15H32C30
 UVH-15H40C30
 UVH-15H50C30

[Unit: in(mm)]

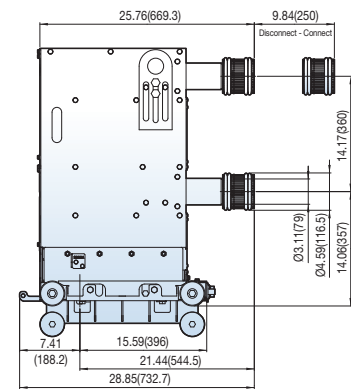
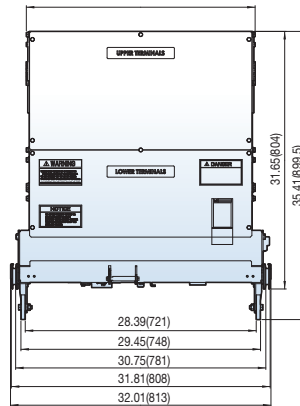
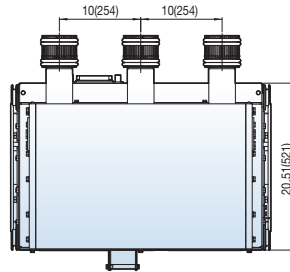

4.76/15kV, 25/31.5/40/50kA, 4000A

Ground and test device model

UCGT-05Ms25L40
 UCGT-05Ms32L40
 UCGT-05Ms40L40
 UCGT-05Ms50L40
 UCGT-15Ms25L40
 UCGT-15Ms32L40
 UCGT-15Ms40L40
 UCGT-15Ms50L40

Related VCB

UVH-05H25L40
 UVH-05H32L40
 UVH-05H40L40
 UVH-05H50L40
 UVH-15H25L40
 UVH-15H32L40
 UVH-15H40L40
 UVH-15H50L40

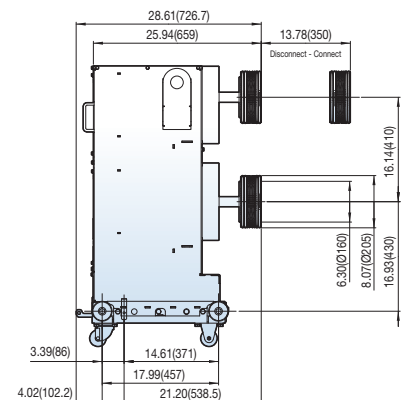
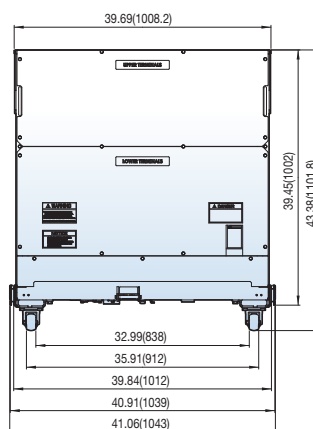
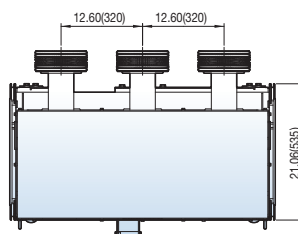

27kV, 25kA, 1200A

UCGT type, Draw-out type

Ground and test device model

UCGT-27Ms25C12

Related VCB

UVM-27H25C12

[Unit: in(mm)]

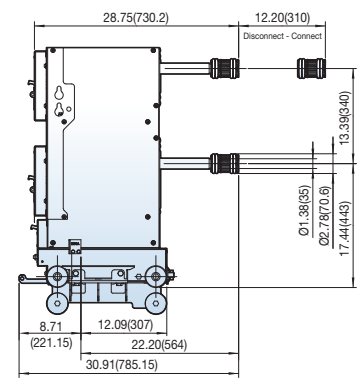
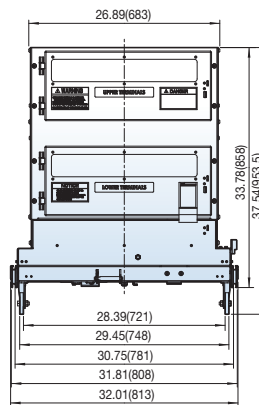
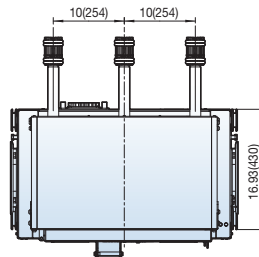

27kV, 25kA, 2000A

Ground and test device model

UCGT-27Ms25C20

Related VCB

UVM-27H25C20

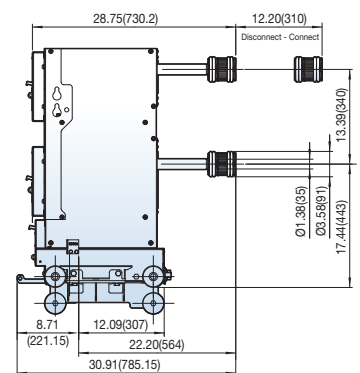
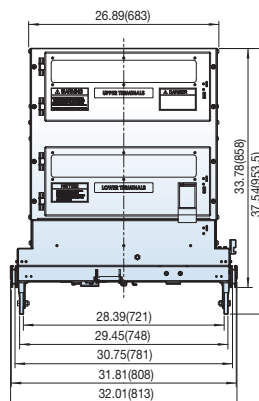
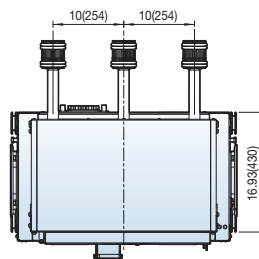

Dimensions

27kV, 31.5/40kA, 1200A

UCGT type, Draw-out type

Ground and test device model

UCGT-27Ms32C12
UCGT-27Ms40C12

Related VCB

UVH-27H32C12
UVH-27H40C12

[Unit: in(mm)]

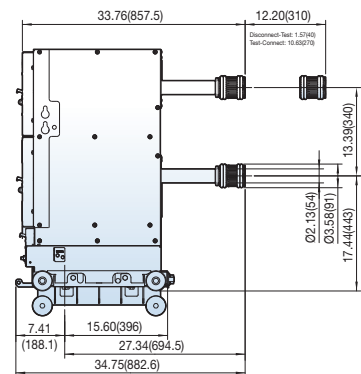
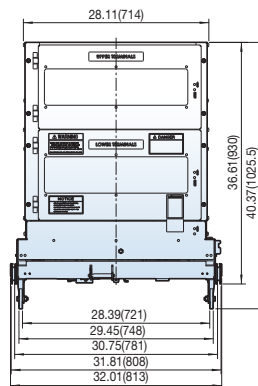
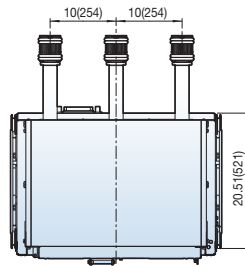

27kV, 31.5/40kA, 2000A

Ground and test device model

UCGT-27Ms32C20
UCGT-27Ms40C20

Related VCB

UVH-27H32C20
UVH-27H40C20

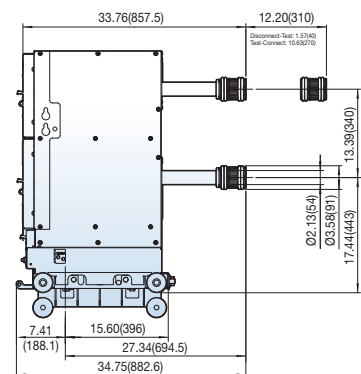
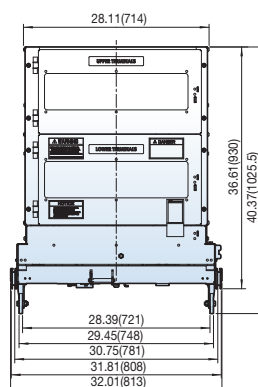
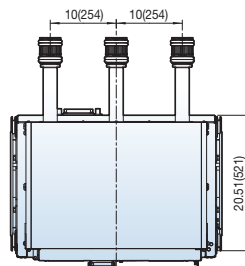

27kV, 25/31.5/40kA, 2500A

UCGT type, Draw-out type

Ground and test device model

- UCGT-27Ms25C25
- UCGT-27Ms32C25
- UCGT-27Ms40C25

Related VCB

- UVH-27H25C25
- UVH-27H32C25
- UVH-27H40C25

[Unit: in(mm)]

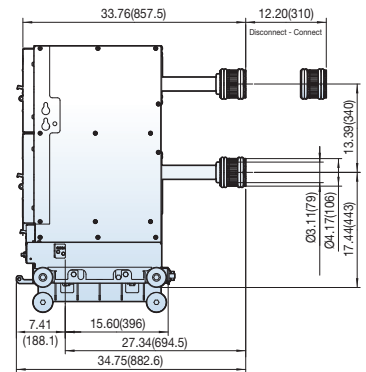
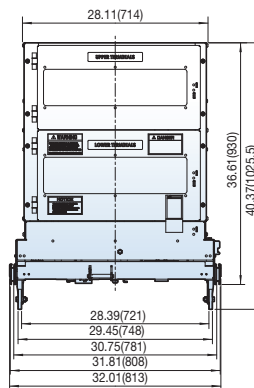
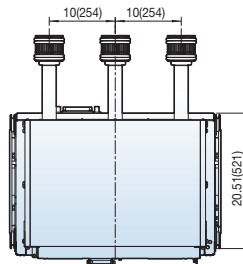

27kV, 25/31.5/40kA, 2750A

Ground and test device model

- UCGT-27Ms25C28
- UCGT-27Ms32C28
- UCGT-27Ms40C28

Related VCB

- UVH-27H25C28
- UVH-27H32C28
- UVH-27H40C28

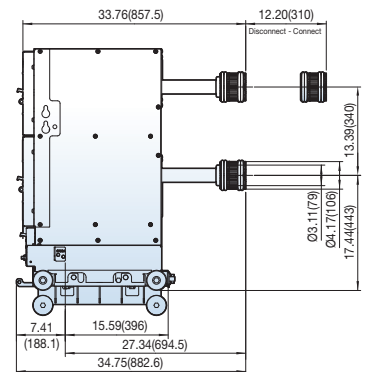
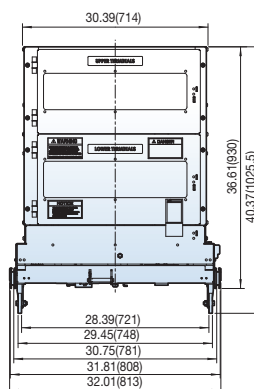
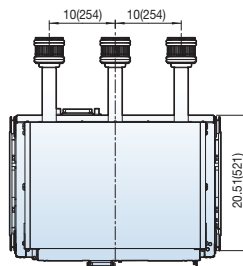

Memo

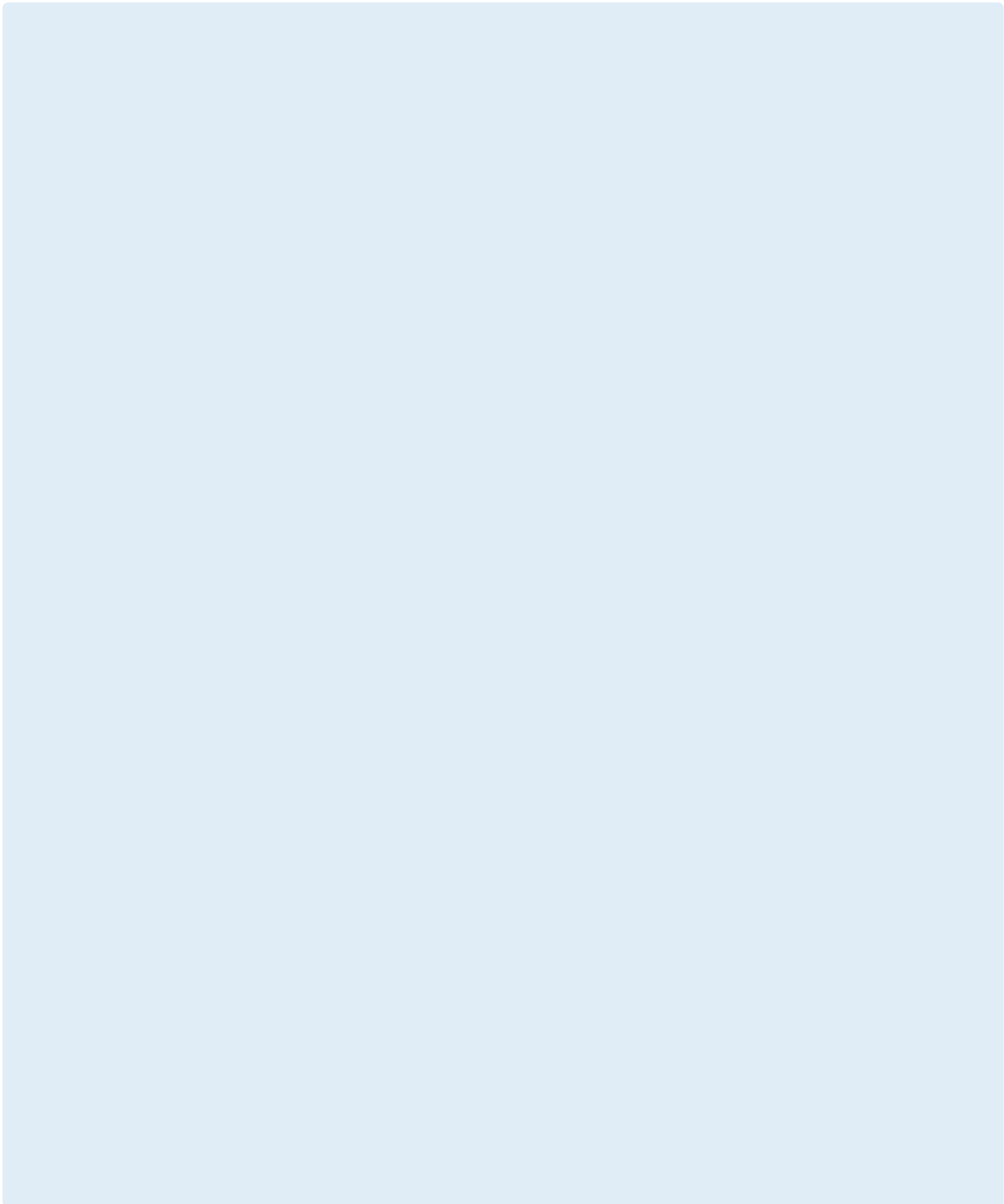

Susol VCB



Contents

▪ Accessory	162
▪ Control circuit diagram	194
▪ Technical data	200

Accessories

Motor: M1~M8

UVL/UVM type

- Charges the closing spring of a circuit breaker by the external power source. When the charging is complete, the control power of the motor will be turned "OFF" by the built-in Limit S/W. Without the external power source, charge manually.

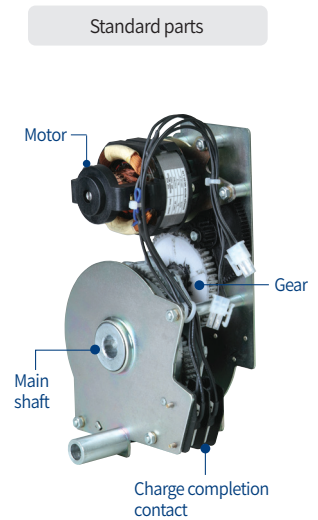
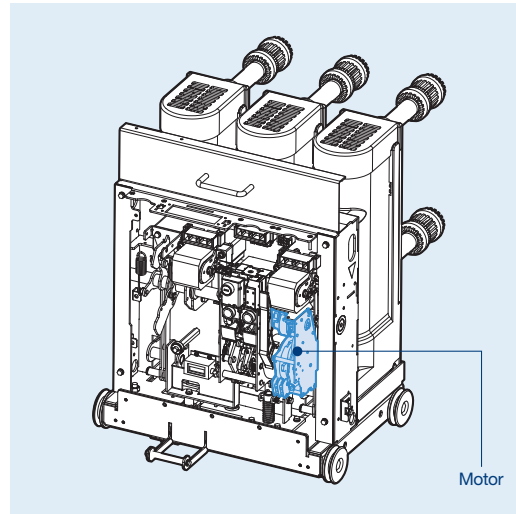

	UVL/UVM type						
Input voltage (Vn)	DC 200V~250V	DC 125V	DC 24V~30V	DC 48V~60V	AC 48V	AC 100V~130V	AC 200V~250V
Load current (A)	≤ 0.5	≤ 1	≤ 5	≤ 3	≤ 3	≤ 1	≤ 0.5
Starting current (A)	5 times of load current						
Charge time	Within 5 seconds at the rated control voltage						

Note) See page 168 for rated operation and control voltage range.

UVH type

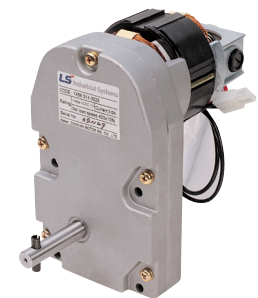
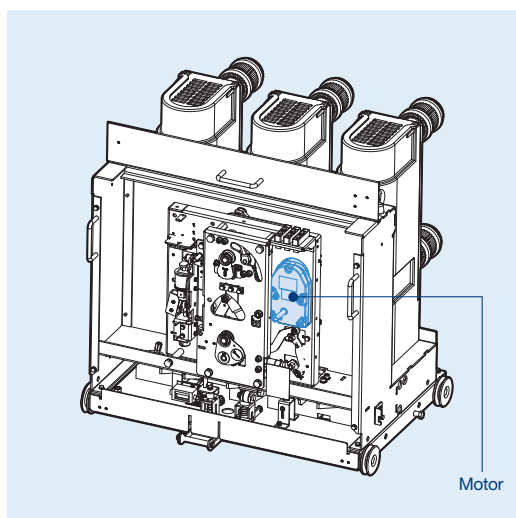

	UVH type						
Input voltage (Vn)	DC 24V~30V	DC 200~250V	DC 125V	DC 48~60V	AC 48V	AC 100~130V	AC 200~250V
Load current (A)	≤ 11	≤ 2.6	≤ 3	≤ 6	≤ 6	≤ 3	≤ 2.6
Starting current (A)	≤ 40	≤ 17	≤ 20	≤ 30	≤ 30	≤ 20	≤ 17
Charge time	Within 12 seconds at the rated control voltage						

Note) See page 168 for rated operation and control voltage range.

Closing Coil: C1~C8

Standard parts

UVL/UVM type

- A control device that closes a circuit breaker when a voltage is applied to the coil control terminals continuously or instantaneously for over 200ms.

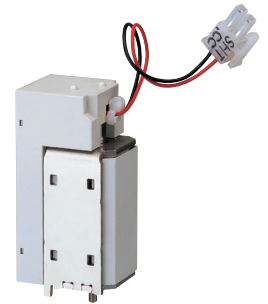
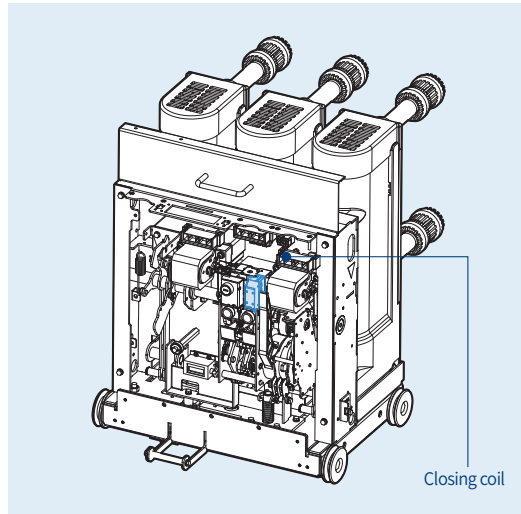

Input voltage (Vn)	UVL/UVM type						
	DC 200V~250V	DC 125V	DC 24V~30V	DC 48V~60V	AC 48V	AC 100V~130V	AC 200V~250V
Power consumption (inrush, VA)	-	-	-	-	200		
Power consumption (steady, VA)	-	-	-	-	≤ 5		
Rated current (A)	≤ 2	≤ 4	≤ 10	≤ 5	-		

Note) See page 168 for rated operation and control voltage range.

UVH type

- A control device that closes a circuit breaker when a voltage is applied to the coil control terminals continuously for over 45ms.

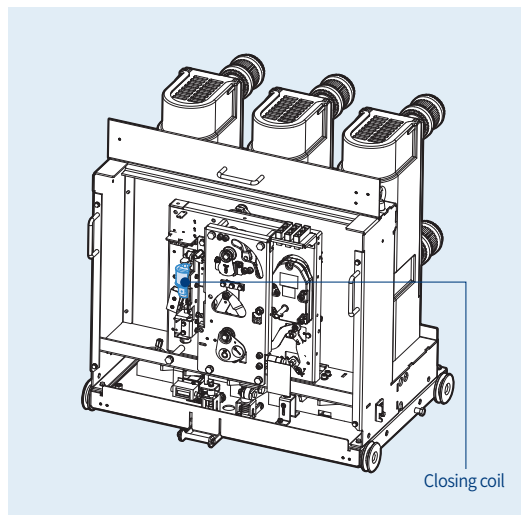

Input voltage (Vn)	UVH type						
	DC 24V~30V	DC 200~250V	DC 125V	DC 48~60V	AC 48V	AC 100~130V	AC 200~250V
Rated current (A)	≤ 10.5	≤ 2.5	≤ 3.5	≤ 8	≤ 8	≤ 3.5	≤ 2.5

Note) See page 168 for rated operation and control voltage range.

Accessories

Trip Coil: T1~T8

UVL/UVM type

- The trip coil is a control device that remotely trips the circuit breaker when voltage is applied to the coil control terminals either continuously or momentarily for more than 35ms.
- When a UVT coil is installed, the installation location of the trip coil is changed.

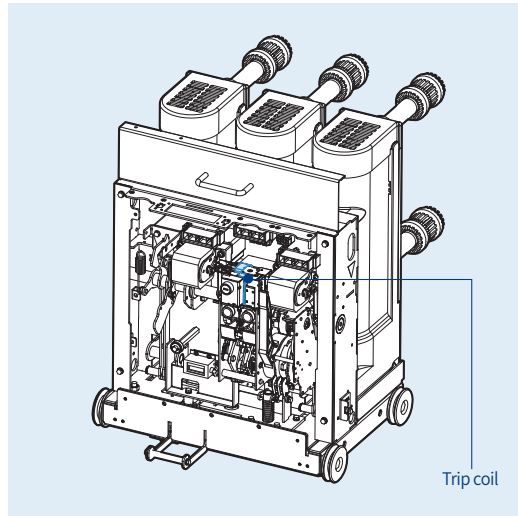

Standard parts

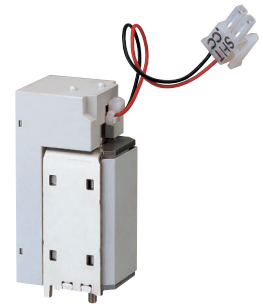

Input voltage (Vn)	UVL/UVM type						
	DC 200V~250V	DC 125V	DC 24V~30V	DC 48V~60V	AC 48V	AC 100V~130V	AC 200V~250V
Power consumption (inrush, VA)					200		
Power consumption (steady, VA)					≤ 5		
Rated current (A)	≤ 2	≤ 4	≤ 10	≤ 5	-		

Note) See page 168 for rated operation and control voltage range.

UVH type

- The trip coil is a control device that remotely trips the circuit breaker when voltage is applied to the coil control terminals either continuously or momentarily for more than 35ms.

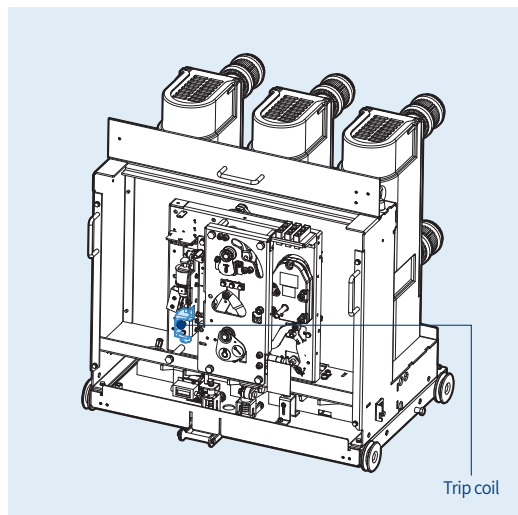

Input voltage (Vn)	UVH type						
	DC 24V~30V	DC 200~250V	DC 125V	DC 48~60V	AC 48V	AC 100~130V	AC 200~250V
Rated current (A)	≤ 10.5	≤ 2.5	≤ 3.5	≤ 8	≤ 8	≤ 3.5	≤ 2.5

Note) See page 168 for rated operation and control voltage range.

Secondary Trip Coil: A1

UVL/UVM type

- The secondary trip coil is a control device that trips the circuit breaker if the primary trip coil (T) fails to operate (acting as a backup trip coil).
- Secondary trip coil: Install on the right side of the trip coil.
- The secondary trip coil is not available when UVT coil is installed.

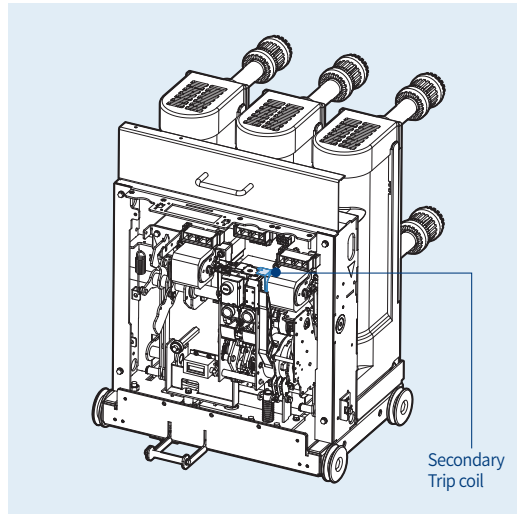

Breaker Options

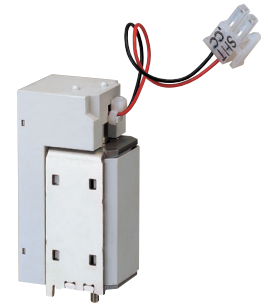

Input voltage (Vn)	UVL/UVM type						
	DC 200V~250V	DC 125V	DC 24V~30V	DC 48V~60V	AC 48V	AC 100V~130V	AC 200V~250V
Power consumption (inrush, VA)					200		
Power consumption (steady, VA)					≤ 5		
Rated current (A)	≤ 2	≤ 4	≤ 10	≤ 5	-		

UVH type

- The secondary trip coil is a control device that trips the circuit breaker if the primary trip coil (T) fails to operate (acting as a backup trip coil).
- The secondary trip coil is not available when UVT coil is installed.

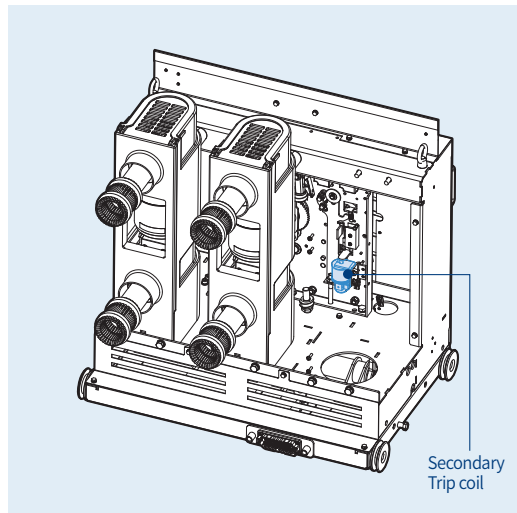

Input voltage (Vn)	UVH type						
	DC 24V~30V	DC 200~250V	DC 125V	DC 48~60V	AC 48V	AC 100~130V	AC 200~250V
Rated current (A)	≤ 10.5	≤ 2.5	≤ 3.5	≤ 8	≤ 8	≤ 3.5	≤ 2.5

Accessories

Rated operation and control voltage range

Rated control voltage range	DC Voltage range		Remarks
	Motor, Closing	Trip	
24	-	24-28	
48	38-56	28-56	
125	100-140	70-140	
250	200-280	140-280	
Standard	IEEE Std C37.04		

Note) Use the rated control voltage for 24V DC control source (M4, C4, T4 and U4).

Rated control voltage range	AC Voltage range	Remarks
	Motor, Closing, Trip	
24	-	
48	-	
120	104-127	
240	208-254	
Standard	IEEE Std C37.04	

Auxiliary Contact: SA2/4, SQ2/4, SC2/4

Standard parts

UVL/UVM type

- A contact used to monitor OPEN/CLOSE status of a breaker remotely.
- The auxiliary contacts supplied as standard configuration is 4a4b. 10a10b is also available on request.

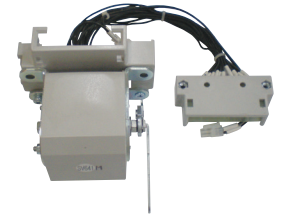
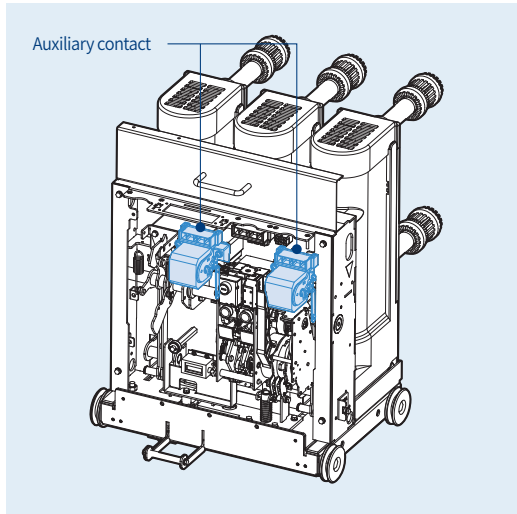

Item	Fixed type			
	UVL		UVM	
	4a4b	10a10b	4a4b	10a10b
Economic	SA2	SA4	SA2	SA4
Standard	SQ2	SQ4	SQ2	SQ4

Item	Draw-out type			
	UVL		UVM	
	4a4b	10a10b	4a4b	10a10b
Standard	SQ2	SQ4	-	-
Auto-con	-	-	SC2	SC4

* For the UVH 38kV fixed type, only SQ2 and SQ4 are currently applicable.

UVH type

Item	Fixed type		Draw-out type	
	UVH		UVH	
	4a4b	10a10b	4a4b	10a10b
Economic	SA2	SA4	-	-
Standard	SQ2	SQ4	-	-
Auto-con	-	-	SC2	SC4

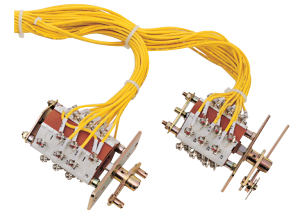
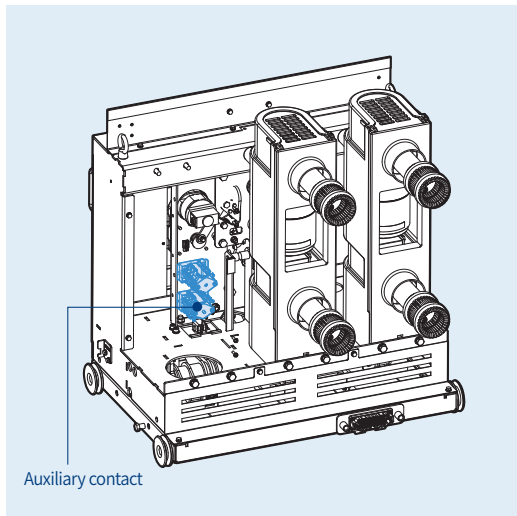

			UVL/UVM/UVH type		Remarks
Item			Resistive load (A)	Inductive load (A)	
Contact configuration	AC	250V	10	5	For all models
		125V	10	5	
	DC	250V	10	5	
		125V	10	5	
		30V	10	5	

Accessories

Under Voltage Trip Coil: U1~U8

Breaker Options

UVL/UVM type

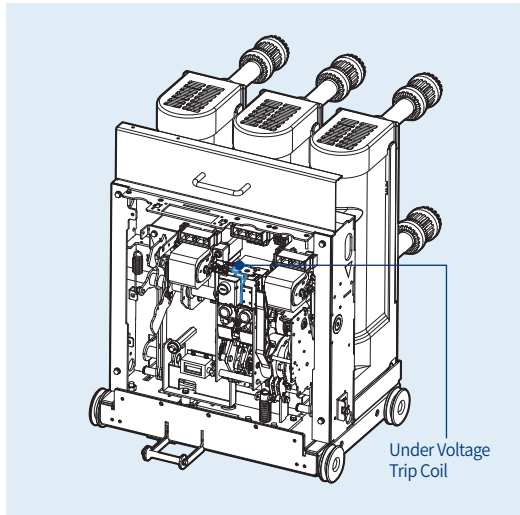

UVH type

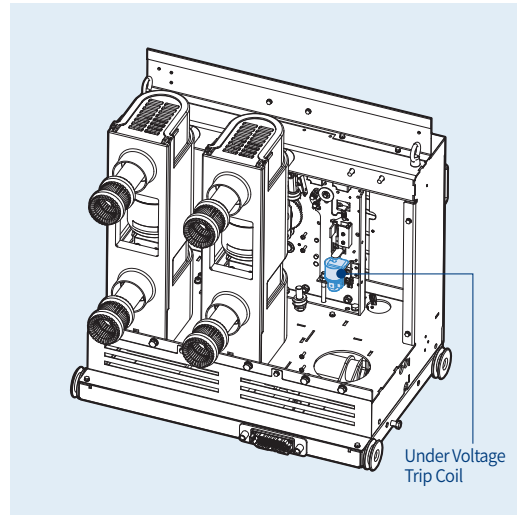

UVM type

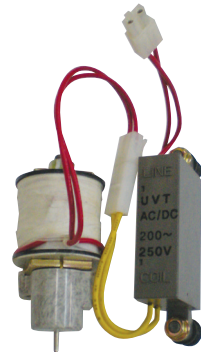

UVH type

- The under voltage trip coil is installed inside a breaker and trips the breaker when the main or control power voltage drops below a certain level. The instantaneous type is available only with a UVT coil, while the time-delay type is available by connecting a UVT coil with a UVT time-delay controller.
- The circuit breaker cannot be closed mechanically or electrically if control power is not supplied to the UVT. To close the circuit breaker, 65–85% of the rated voltage must be applied.
- UVT and secondary trip coil will not be selected together.

* UVT is only applicable for Fixed type (P type)

1. UVT rated voltage and characteristic

- Operating voltage range: Pick up 0.65~0.85Vn, Drop out 0.4~0.6Vn
- Operating voltage ranges based on the minimum value of each rated voltage (Vn)

Input voltage (Vn)	UVL/UVM type						
	DC 200~250V	DC 125V	DC 24~30V	DC 48~60V	AC 48V	AC 100~130V	AC 200~250V
Power consumption (inrush, VA)	200						
Power consumption (steady, VA)	≤ 5						

Input voltage (Vn)	UVH type					
	DC 200~250V	DC 125V	DC 48~60V	AC 48V	AC 100~130V	AC 200~250V
Power consumption (inrush, VA)	350					
Power consumption (steady, VA)	≤ 10					

Position Switch: A3, A4, A5

Breaker Options

UVL type

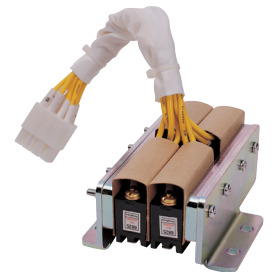
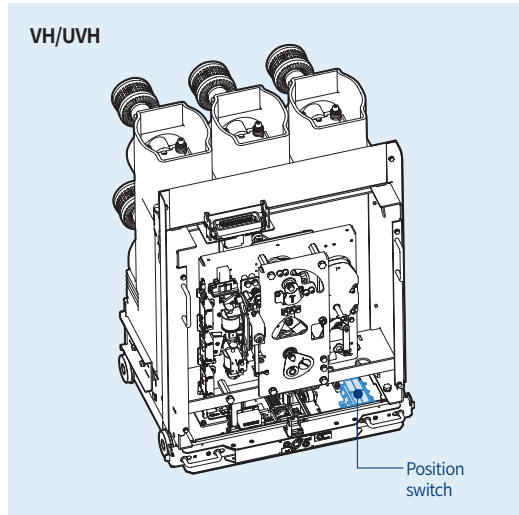
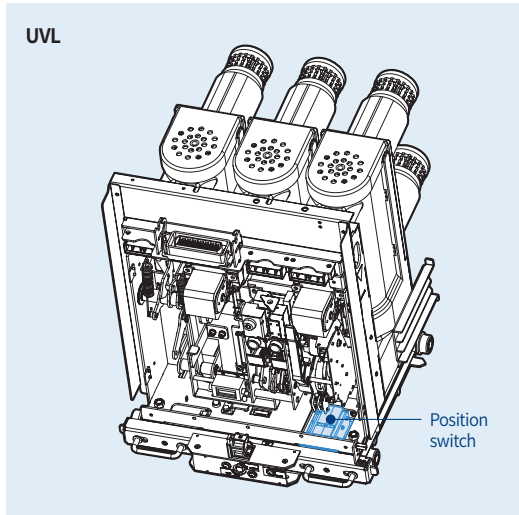

Large model (VH/UVH)

- This switch is used to indicate the breaker position (CONNECT, TEST). The contact configuration is 2a2a, 2a2b or 1a3b.

Contact configuration

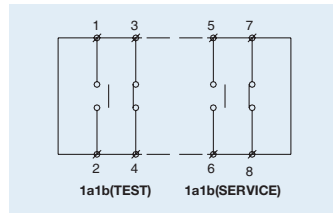
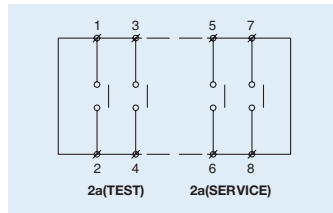
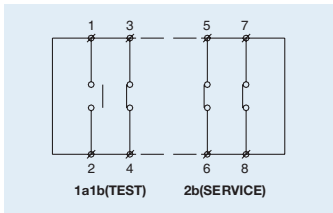

Latch checking switch: A6

Breaker Options

UVH type

- The latch checking switch works in conjunction with the breaker's mechanism to check whether the breaker is ready to be closed.
- When the mechanism is OFF and the closing spring is charged, the switch turns ON, which means the mechanism is ready to close.
- If the latch is not in the proper position, the switch prevents the breaker from closing. For the VH type, it is internally connected in series with the closing coil.

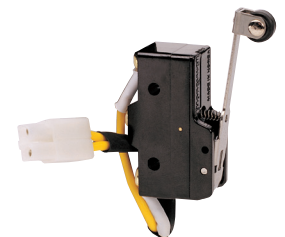
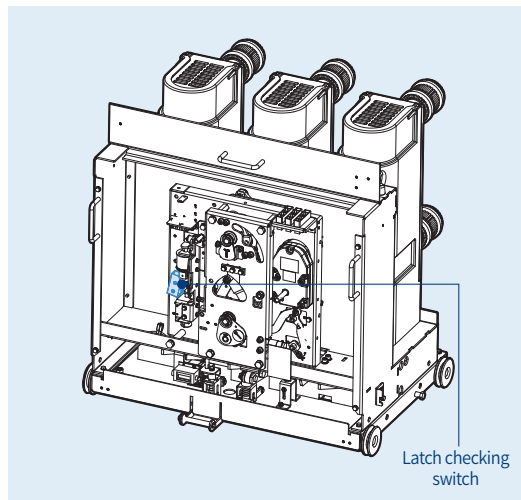

Accessories

Keylock: A7, AM, AN, AP

Breaker Options

UVL/UVM type – A7, AM, AN, AP

- The key is used to unlock the locking device before attempting to close the breaker either electrically or mechanically.

*How to operate

- The key can only be removed when in the locked position.
- Press the breaker's "OPEN" switch, turn the key counter clock wise to the locked position, and then remove it.
- The breaker cannot be closed electrically or mechanically while in the locked position.
- To unlock, insert the key and turn it clockwise to the unlocked position. The breaker can then be closed.

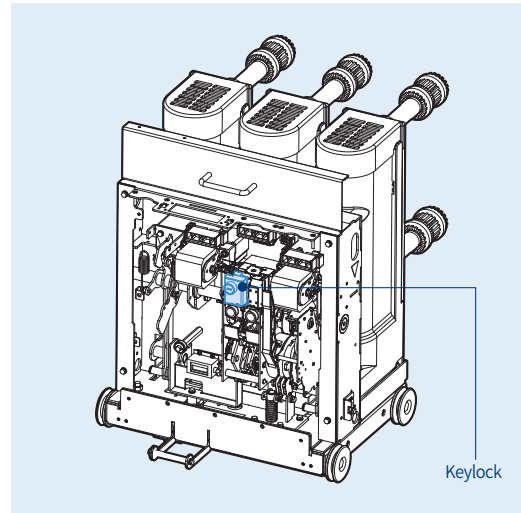

Keylock Types

1. A7: Keylock (Normal Type)
2. AM: KIRK Keylock (Camlock Type)
3. AN: KIRK Keylock (CN22 Type)
4. AP: KIRK Keylock (Double Camlock Type)

Note) The KIRK key is not provided separately when selecting the AM, AN, or AP option. A mounting bracket and an instruction manual are included.

* Refer to the KIRK key order information below:

- 1) AM, AP: Type "C" Camlock (Part number: KCAM00010)
- 2) AN: Type KC40 (Part number: KC40-10)

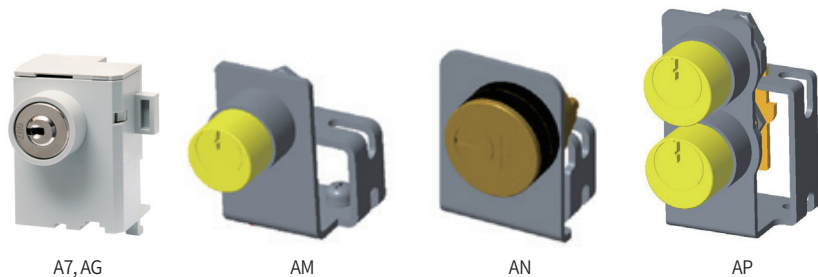

A7, AG

AM

AN

AP

UVH type - A7, AM

*How to operate

- The key is used to unlock the locking device before attempting to close the breaker either electrically or mechanically.
- The breaker cannot be closed electrically or mechanically while in the locked position.
- Make sure the breaker is in the open position before using the key.
- Turn the key counter clockwise to the locked position and remove it.

Keylock Types

1. A7: Keylock (Normal Type)
2. AM: KIRK Keylock (Camlock Type)

Note: The KIRK key is not provided separately when ordering the AM option. A mounting bracket and an instruction manual are included.

* KIRK Key Order Information below:

- 1) AM: Type "C" Camlock (Part number: KCAM00010)

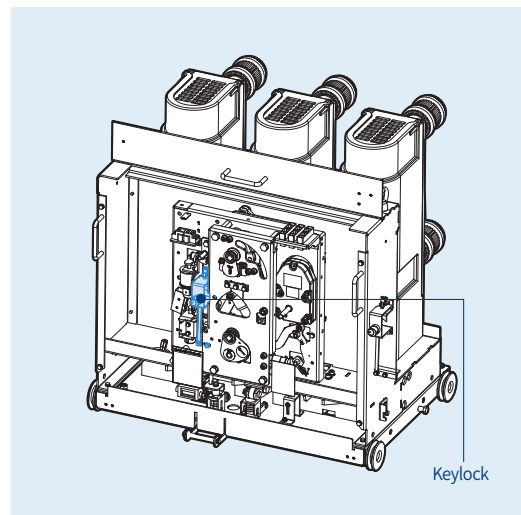

Button Padlock: A8, AX

UVL/UVM type

- This device prevents manual operation of the OPEN/ CLOSE buttons.
- A8 option: Manual operation is not possible when the padlock is locked.
- AX option: Manual and electrical operation are both disabled when the padlock is locked. The keylock is not included.

* Key lock not included.

Options

1. A8: Normal type Button Padlock
2. AX: Button Padlock
(Open position only, for UVM type only)

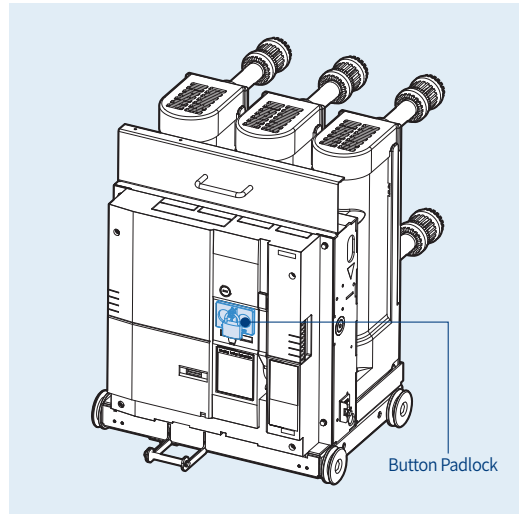

Breaker Options



UVL/UVM type

UVH type

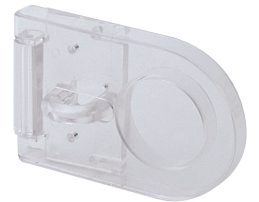
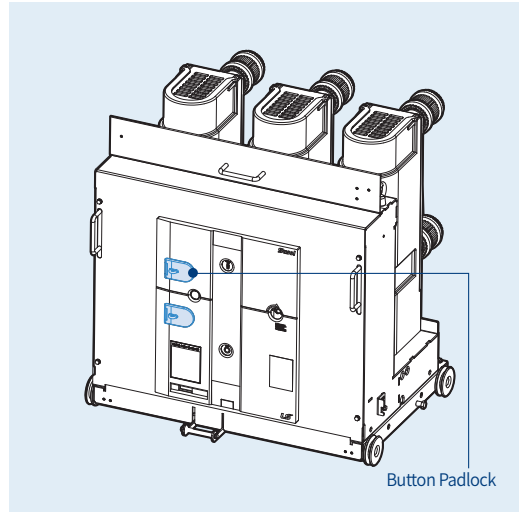

UVH type

Accessories

Lead wire: AA(breaker option) or A1,A2(Cradle option)

UVL/UVM/UVH type

- Connects to the circuit breaker controls (wire length: 2 m)
- An A/Q-type connector is supplied for the P-type UVM/UVH VCB.

Note) The standard lead wire length is 2 m. For additional length, please contact LS Sales.

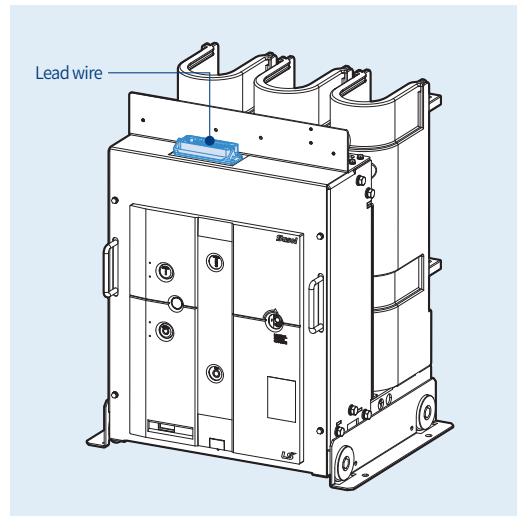

Breaker Options



A type connector

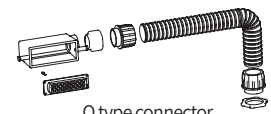

Q type connector

Lead wires by VCB model

VCB model	Cradle type	P	H
UVL/UVM		Enclosed in the breaker	Enclosed in the breaker Installed in the cradle (option)
UVH		Enclosed in the breaker	Enclosed in the breaker Installed in the cradle (option)

Plug/Terminal for lead wire: AB

Breaker Options

UVM/UVH type



A type connector



Q type connector

- It is a connector used to connect with the connector installed in the breaker (only connectors and terminals for the lead wire are supplied).
- The type of connector depends on the type installed in the breaker---either A or Q.
- Length of the flexible tube: 600 mm (23.6 inches).

Plug interlock: AC

Breaker Options

UVL type

- Verifies whether the control power on the cradle (H-type) is connected to the breaker terminal before drawing in or out.
- Prevents disconnection of the control power connector from the breaker in the draw-in/out or CONNECT positions; disconnection is only allowed in the TEST position.

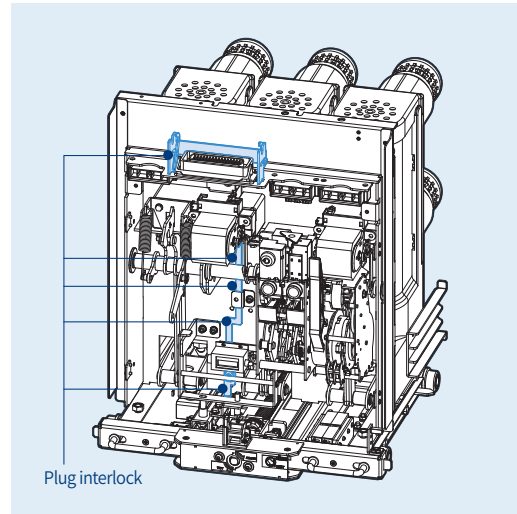

Padlock/Door racking interlock: AD

Breaker Options

UVL type

- Allows draw-in/out with the door closed.
- When draw-in/out is necessary while the door is open, use the operation lever.
- An optional padlock prevents draw-in/out of the breaker in the TEST and CONNECT positions.

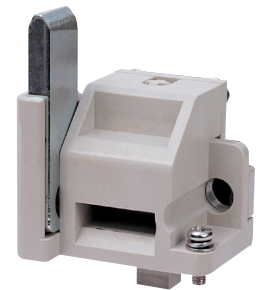
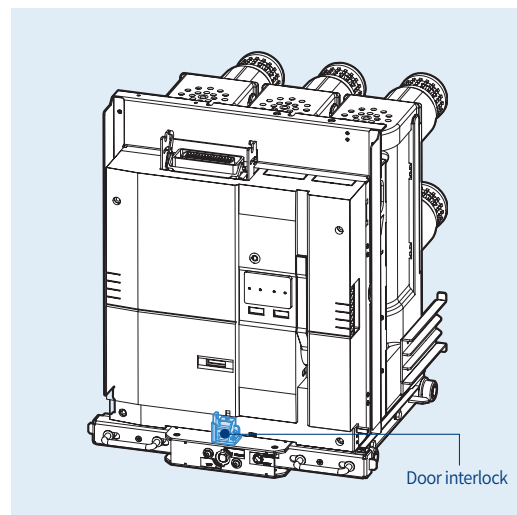

Accessories

MOC operator: AE

UVL/UVM type

- It must be installed in the breaker to operate the MOC installed in the cradle.
- The MOC (Mechanically Operated Cell switch) is a device that indicates the CLOSE/OPEN status of the VCB in the 'TEST' and 'CONNECT' positions.
- This MOC operator in the breaker should be installed when the MOC in the cradle is used.

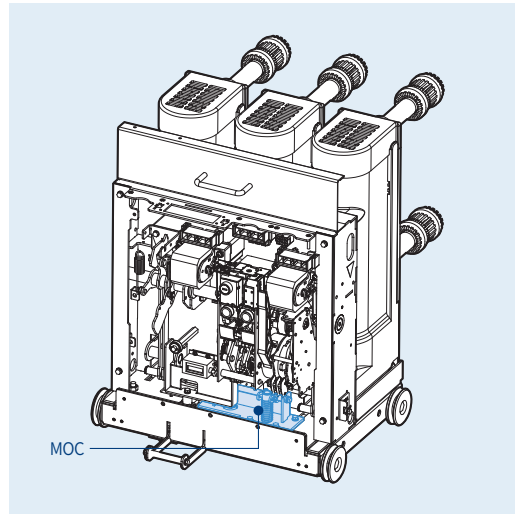

Breaker Options

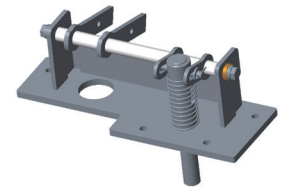

<UVM>

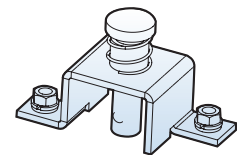

<UVL>

UVH type

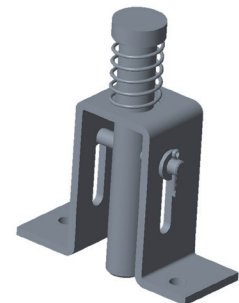
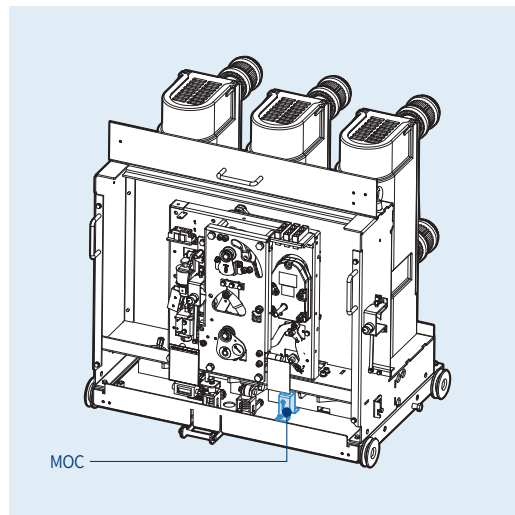

<UVH-05/15>

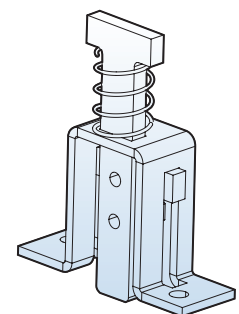

<UVH-38>

Auxiliary Wheels(Direct Roll-in): AS

Breaker Options

UVM/UVH-05/15/27H

- The direct roll-in option is designed to allow insertion and removal of the circuit breaker without any special devices.
- Wheel kits are assembled on both sides.
- It is possible to roll the circuit breaker in and out without any modification to the CB compartment.

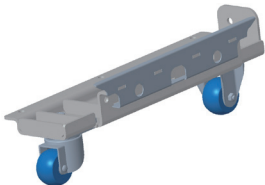
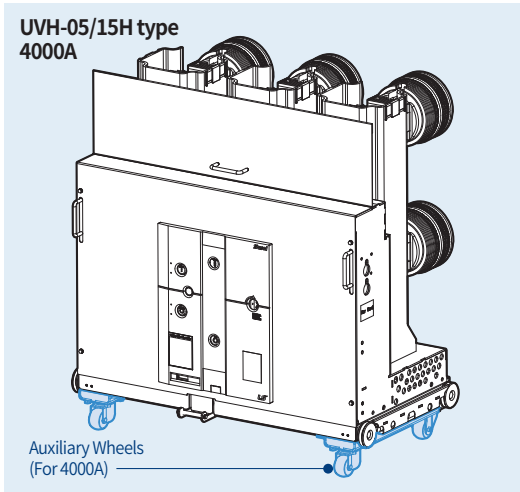
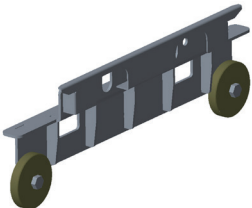
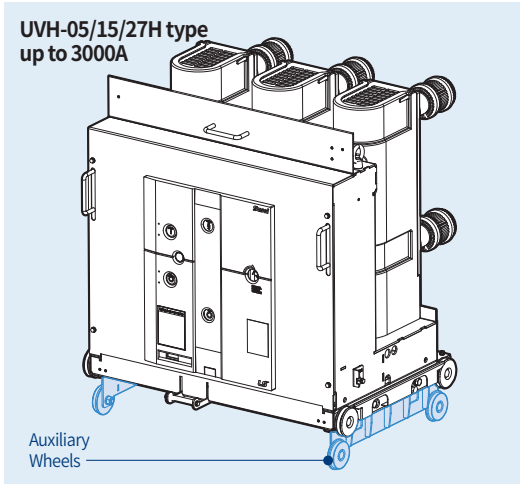
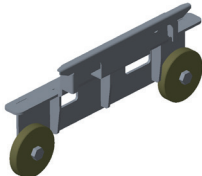
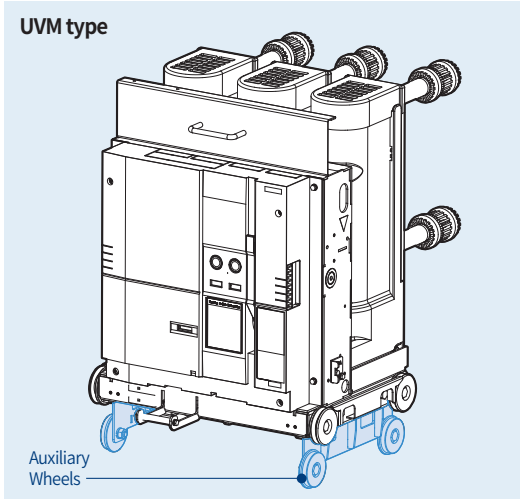

Trip coil monitoring contact: A2

Breaker Options

UVL/UVM type

- Device for monitoring the functions of the trip coils.
- Supplied as standard for the UVM model and optional for the UVH model.
- To monitor the trip coils, connect its terminals to the trip coil monitoring relay as shown in the circuit diagram.
 - If the trip coil is normal, the circuit is closed.
 - If the trip coil is damaged, the circuit is open.
- 1) Terminals A5 and A6 monitor the trip coils when the breaker is in the closed position.
- 2) Terminal A6 and auxiliary contact terminal 34 monitor the trip coils when the breaker is in the trip position.
- The Coil Test Unit is optional and enables coil monitoring by connecting in parallel with the trip coil operation switch.
- In the case of UVL/UVM/UVH types, this contact works with trip coils such as T2, T3, T4, and T5.

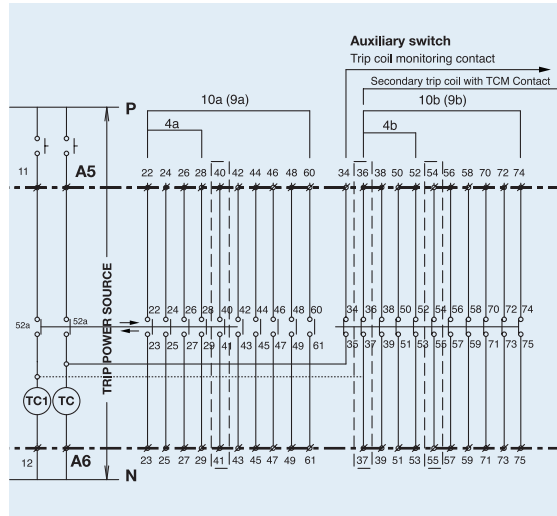

UVH type

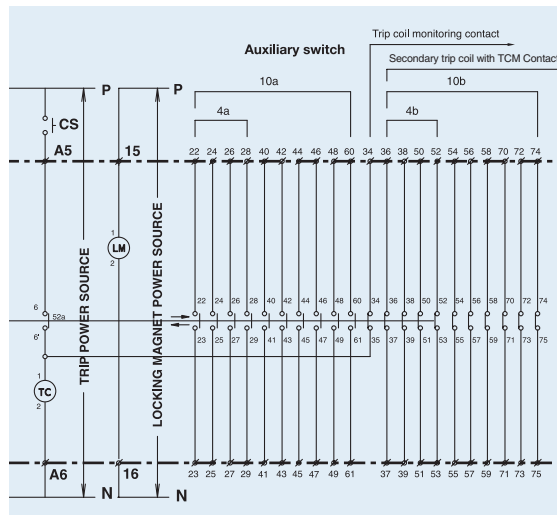

Coil Test Unit: CTU

Breaker Options

UVL/UVM/UVH type

- When no current flows through the coil, a test current-which does not cause the coil to operate-is supplied to check whether the coil is disconnected.
- If the test current flows normally: coil is normal.
- If the test current does not flow: coil is disconnected.

- ※ As it is connected in parallel with the coil's control circuit, normal coil operation is not affected.
- ※ Monitoring of coils that are running is not possible.
- ※ One test unit can monitor up to two coils.

1. Input voltage: AC/DC 75 V to 264 V
2. Contact output:
 - 1) 2 × a contacts for Fail indication and 2 × a contacts for Alarm
 - 2) 250 Vac/10 A Resistive, 30 Vdc/10 A Resistive
3. Disconnection test cycle is 12 seconds (Test LED blinks)
4. Default operation:
 - If failure occurs (coil disconnected), the Fail LED turns on and the Fail contacts close.
 - If failure occurs three times consecutively, the Alarm LED turns on and the Alarm contacts close.
 - To clear the Alarm status, push the DIP switch on the front up and then down (Off → On → Off)

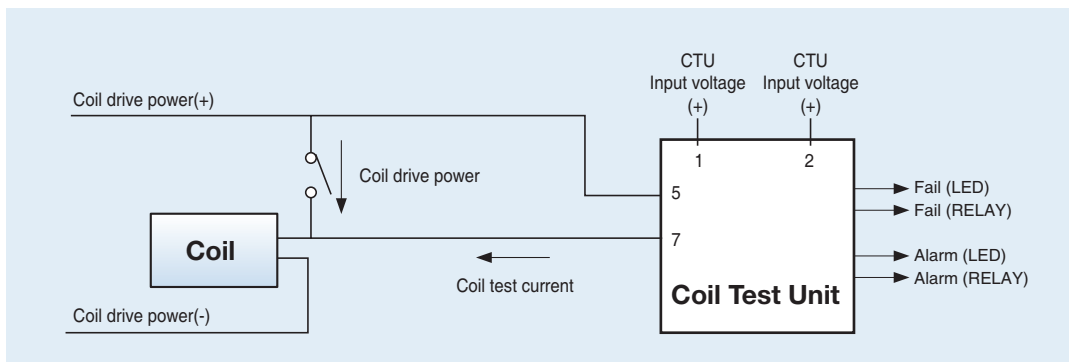
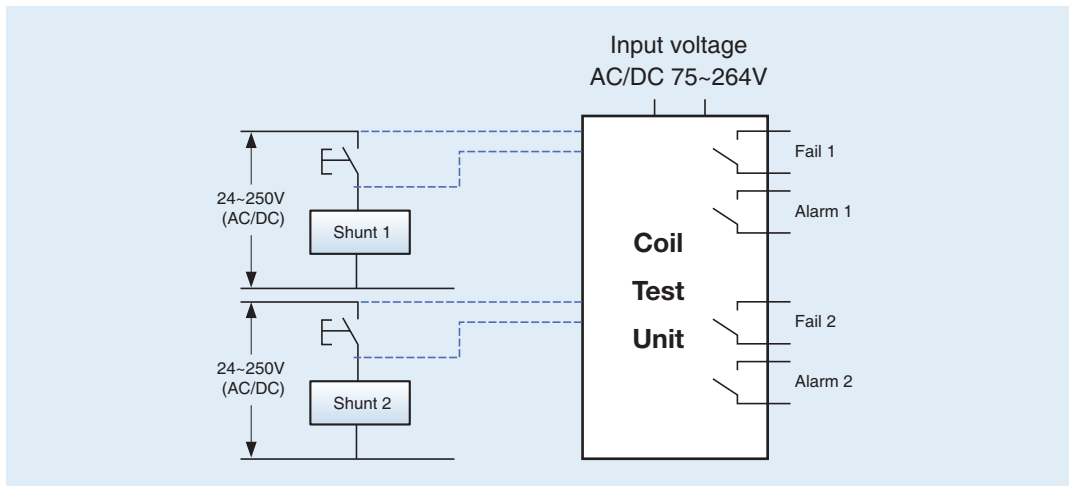
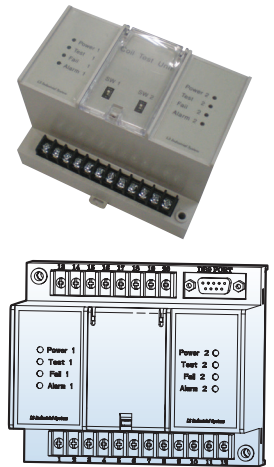

Accessories

Condenser trip device: CTD

Breaker Options

Ratings

Ratings	Specification	
Model	CB - T1	CB - T2
Rated input voltage (V)	AC 100/110 DC 125	AC 200/220 DC 250
Frequency (Hz)	60	60
Rated charge voltage (V)	DC 140/155 DC 125	DC 280/310 DC 250
Charging time	Within 10sec.	Within 10sec.
Trip time window	Less than 1 Min	Less than 1 Min
Input voltage range (V)	85%~110% DC 100~140	85%~110% DC 200~280
Condenser capacity (μF)	1,000	560

UVL/UVM/UVH type

- The condenser trip is a device that electrically trips the circuit breaker within a certain period when the control power is turned off. It is used in combination with a trip coil.
- Even in the event of a power failure, a trip can occur within 30 seconds. However, the automatic trip circuit after a power failure must be separately configured in the switchgear.

* Be sure to observe the correct polarity when connecting the DC input.



Terminal arrangement

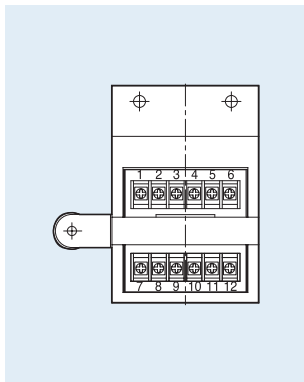

External dimension

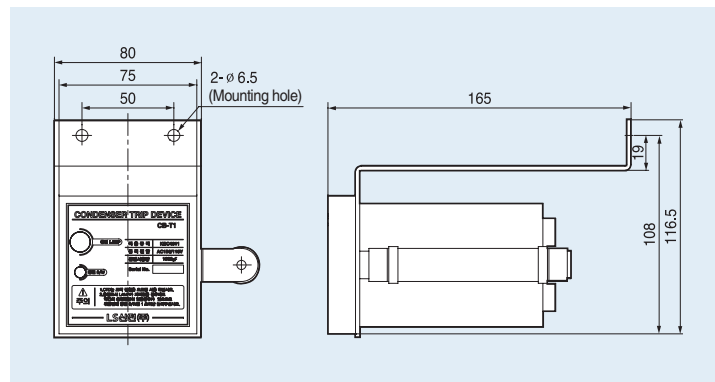

Circuit diagram

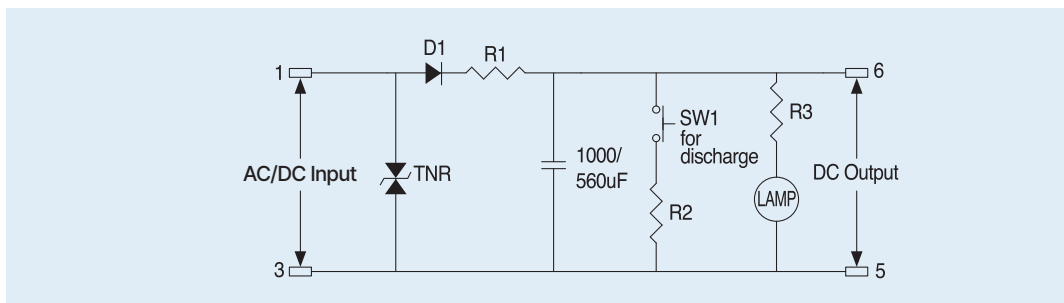

UVT Time delay: UDC

UVL/UVM/UVH type

- The UVT time delay device, UDC, delays the trip signal from the UVT. Without the UDC, the breaker will trip instantaneously upon receiving the trip signal from the UVT installed inside the breaker, even during a momentary power failure.
- The UDC delays the trip time to prevent unintended instantaneous trips during such power failures.
- It can be installed on the cradle or inside the switchgear.
- The UDC provides output contacts to indicate the trip status caused by the UVT coil inside the breaker.
 - The b contact is closed in the normal state, and the a contact is closed when tripped.

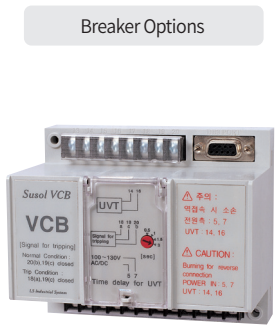

1. Characteristics

Rated voltage (Vn)		Operation voltage range (V)		Consumption (VA or W)		Time delay (ms)
DC (V)	AC (V)	Pick up	Drop out	Inrush	Steady - state	
48~60	48	0.65~0.85 Vn	0.4~0.65 Vn	200	≤ 5	0.5, 1, 1.5, 3
100~130	100~130					
200~250	200~250					

- Operating voltage ranges are based on the minimum value of each rated voltage (Vn)

2. Output contact ratings

Rated voltage (V)	Rated current (A), Resistive load	Max. switching voltage (V)	Max. switching current (A)
24V DC	≤ 12	250V AC	15
120V AC	≤ 12		
250V AC	≤ 10		

3. Wiring diagram

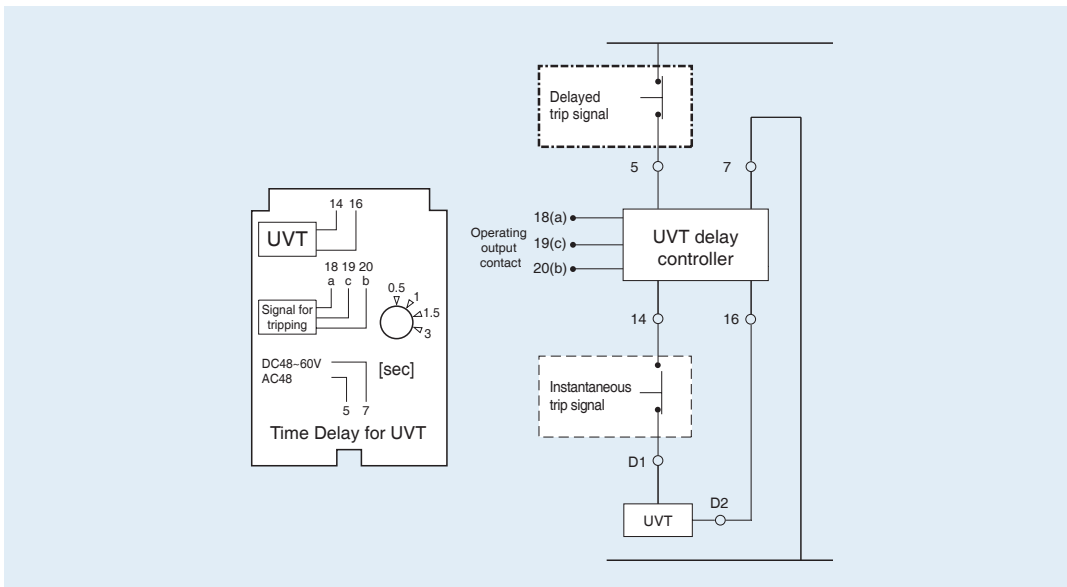

Accessories

Shutter padlock

UVL/UVM/UVH type

- This is a locking device that secures the primary and secondary shutters in the closed position for safety during breaker maintenance when it is drawn out.
- When the breaker is drawn in, the shutters open automatically.
- A hole is provided for padlock installation to lock the shutters.
- Applicable only to H-type cradles.

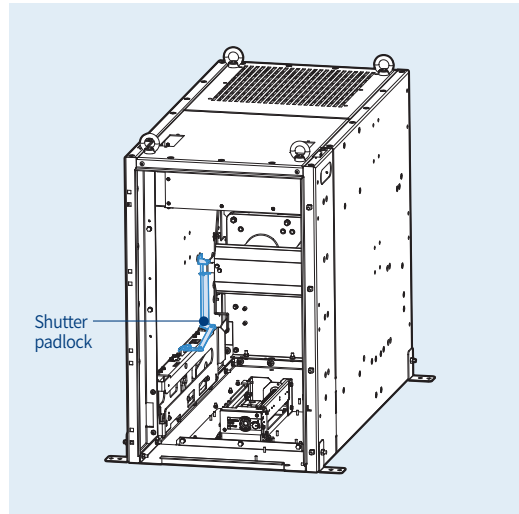

Cradle Options

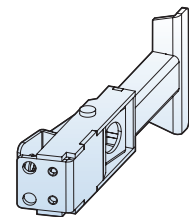

<UVL/UVH-38>



<UVM/UVH-05/15/27>

Truck operated cell switch (TOC)

UVL/UVM/UVH type

- This auxiliary switch is used to indicate the 'CONNECT' position of the VCB. It is installed at the bottom of the cradle and is operated by the frame of the breaker.
- The auxiliary contacts provided are 6a6b.

Circuit diagram (UVM/UVH-05/15/27 Type)

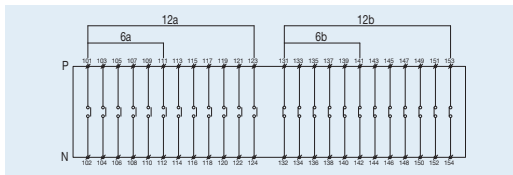

- a Contact: 101-102, 103-104, 105-106, 107-108, 109-110, 111-112, 113-114, 115-116, 117-118, 119-120, 121-122, 123-124
 b Contact: 131-132, 133-134, 135-136, 137-138, 139-140, 141-142, 143-144, 145-146, 147-148, 149-150, 151-152, 153-154

Circuit diagram (UVL/UVH-38)

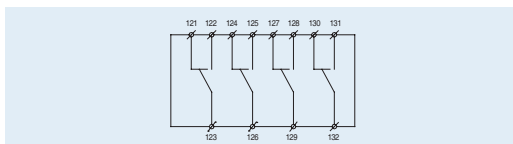

- a Contact: 122-123, 125-126, 128-129, 131-132,
 b Contact: 121-123, 124-126, 127-129, 130-132

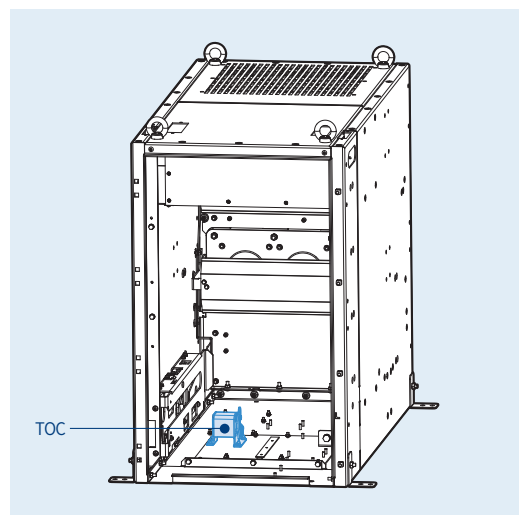

Cradle Options

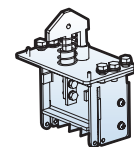

<UVL>

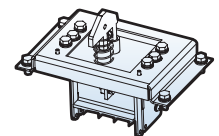

<UVH-38>

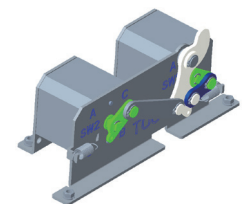

<UVM/UVH-05/15/27>

Mechanical Operated Cell Switch (MOC)

UVM/UVH type

- The Mechanically Operated Cell Switch (MOC) is used to indicate the CLOSE/TRIP status of the VCB. It is mechanically operated in the 'TEST' and 'CONNECT' positions. It is installed at the bottom of the cradle and is actuated by a part of the breaker.
- The standard auxiliary contact configuration is 6a6b. A 12a12b configuration is also available upon request.

Circuit diagram (UVM/UVH-05/15/27)

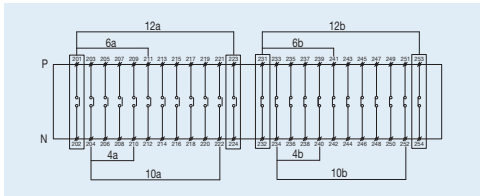

- a Contact: 201-202, 203-204, 205-206, 207-208, 209-210, 211-212, 213-214, 215-216, 217-218, 219-220, 221-222, 223-224
- b Contact: 231-232, 233-234, 235-236, 237-238, 239-240, 241-242, 243-244, 245-246, 247-248, 249-250, 251-252, 253-254

※ In case of selecting Remote Racking System, maximum contacts are 4a4b, 10a10b respectively. (Blocked contacts of diagram are not included.)

Circuit diagram (UVL/UVH-38)

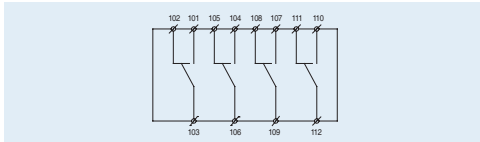

- a Contact: 101-103, 104-106, 107-109, 110-112,
- b Contact: 102-103, 105-106, 108-109, 111-112

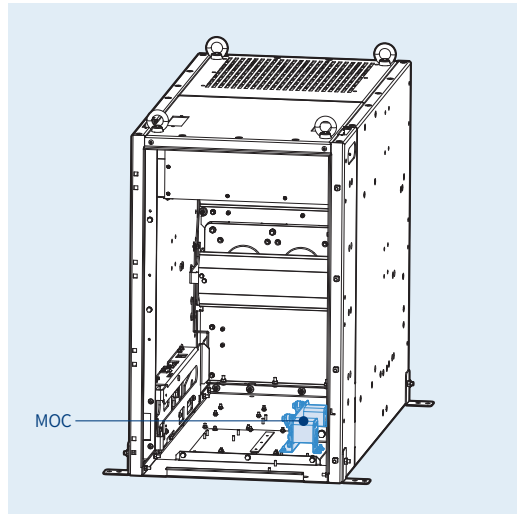

Cradle Options

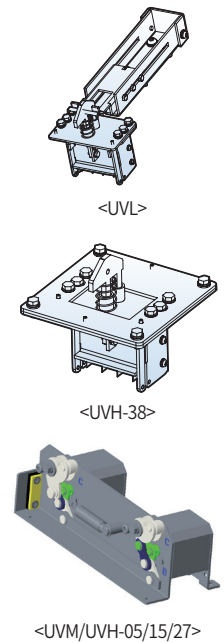

Padlock/Door racking interlock: A5

UVM H-type/UVH-05/15/27 H type

- With this door option for the H-type cradle, draw-in/draw-out operation is allowed only when the door is closed.
- A padlock is also available as an option, which can be used to lock and prevent the draw-in/draw-out of the breaker.

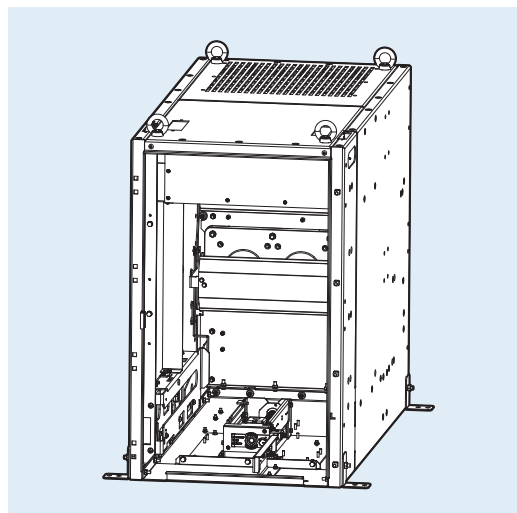

Cradle Options

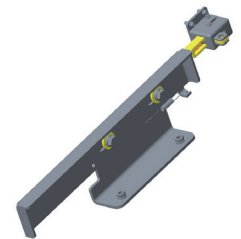

Accessories

Kirkkey Interlock: A9

UVM H-type/UVH-05/15/27 H type

- The KIRK key interlock prevents the racking in/out of the breaker by blocking the block assembly.
- If the Remote Racking System (RRS) is selected, this option must also be selected.

* The KIRK key is not provided.

** KIRK key part number: KFL010010

*** Key operation is only possible when the circuit breaker is in the DISCONNECT position.

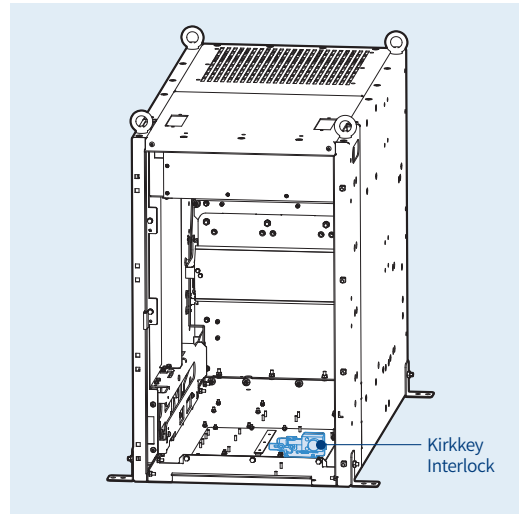

Cradle Options

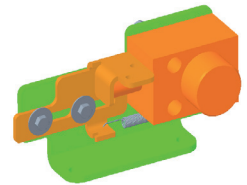

Door: AH

UVL/UVM/UVH C, H type

- This is the outer door for the H-type cradle.
- Accessories are available for the door.
- Type C is only available for UVM/UVH models.

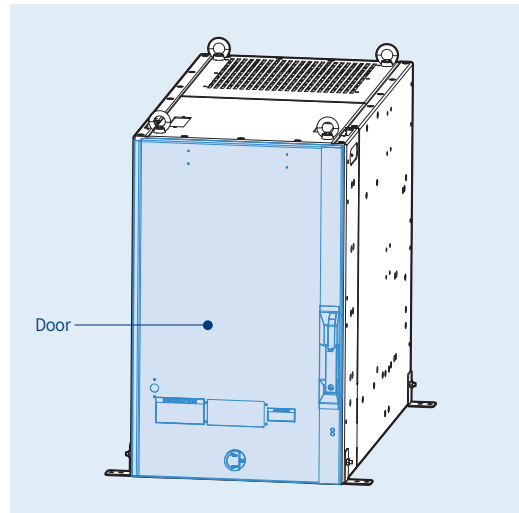

Cradle Options



Door Interlock: AJ

UVL/UVM/UVH H-type

- The door interlock prevents the cradle door from being opened unless the circuit breaker is in the “DISCONNECT” position.

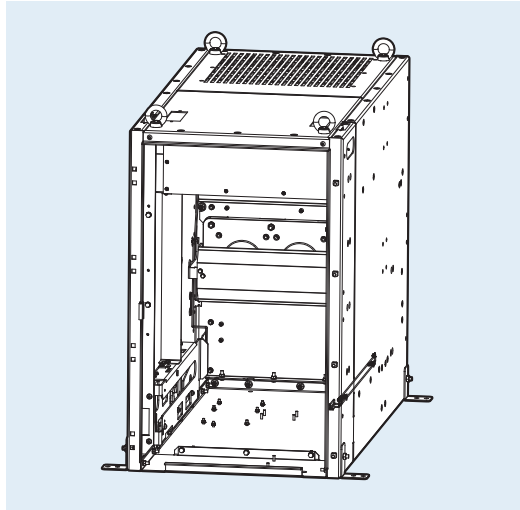

Cradle Options



Door Emergency Push button: A8

UVH-38 H-type

- It is used to manually operate the CLOSE/TRIP function of the breaker from outside the door installed on the H-type cradle during an emergency.
- Press the ON/OFF button using the ON/OFF handle, which is supplied separately.

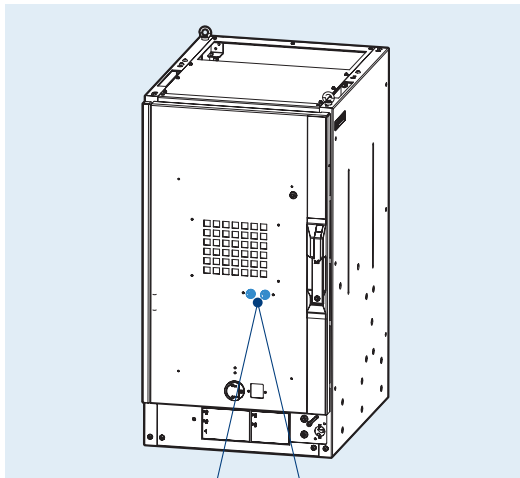

Cradle Options

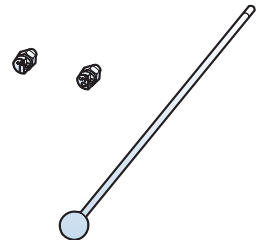

Door Emergency Push button

Accessories

Door Padlock

UVL/UVM/UVH H-type

- It is supplied as a standard door for the H-type cradle.
- It can be locked with a separate padlock to prevent use of the manual handle.

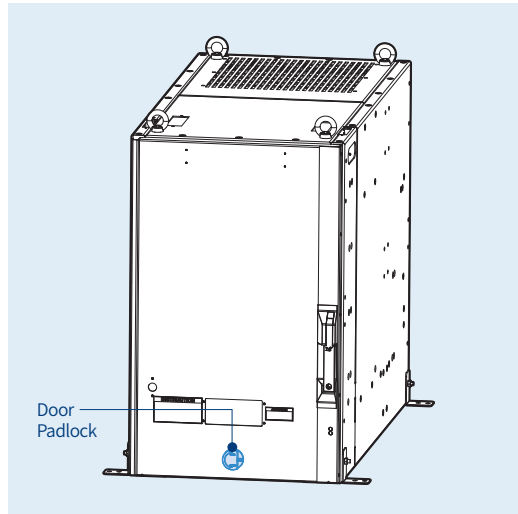

Standard parts

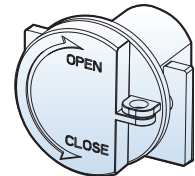

Position padlock

UVH-38H-type

- It is located at the screw hole to prevent the breaker from being drawn in or out from any position.

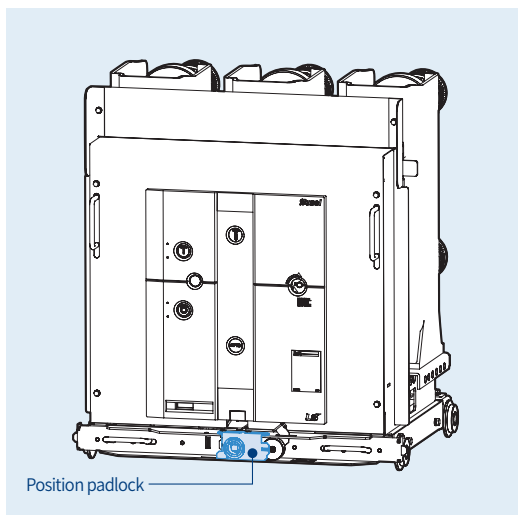

Standard parts

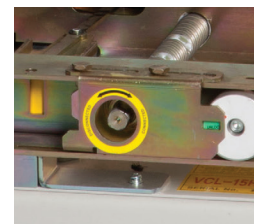

Motorized Control Racking System (MCRS)

Motorized control racking provides a safer operating environment by increasing the distance between the operator and the arc flash incident energy at the switchgear site.

Internal Motor Type

1	Input Power (+)	1	Frame Ground Connection
2	Input Power (-)	2	DISCONNECT Position Micro S/W(R1, R2)
3	Motor Output Power (+, -)	3	TEST Position Micro S/W(R3, R4)
4	MCB & MOC(M1, M2) Connection	4	CONNECT Position Micro S/W(R5, R6)
5	Modbus Control Connection(RS485)	5	PLC Function Use S/W Connection
6	Modbus Control Connection(RJ45)	6	MCRS Key Lock Connection(R9, R10)
7	MOC Close" a" Contact: 201, 202)	7	User Interlock Connection(GPIO2)
8	MOC Open" b" Contact: 231, 232)	8	PLC Control Connection(RJ45)
9	Manual Rack In/Out Micro S/W(R7, R8)	9	Pendant Control Connection(RJ45)

External Motor Type

- Trolley
- MCRS Controller
- Main Cable
※ MCRS-ERS□&ERO□ Only
- Tool Basket
- MCRS Motor
- MCRS Pendant
- MCRS Bracket

Type	Control Power	Item Code	Remote Racking	VCB Status	VCB Open/Closed	Remark
MCRS-ERXA	AC120V/DC125V	72313181327	●			
MCRS-ERXB	AC240V/DC250V	72313181328	●			
MCRS-ERXA-P	AC120V/DC125V	72313181333	●			For UVH-38 ONLY
MCRS-ERXB-P	AC240V/DC250V	72313181334	●			For UVH-38 ONLY

Note) For status (position and Open/Closed) checking and Open/Closed operation of the VCB, please contact your LSE salesperson.
(This does not apply to 38kV VCB.)

Accessories

Insulation ring: AS

UVCH-38H-type

- It is additionally installed on the bushing terminal to increase the lightning impulse voltage withstand level from 150 kV to 170 kV.
- For 1200 A and 2000 A ratings:
Since three insulation rings must be additionally installed per bushing terminal, a total of eighteen rings are supplied.
- For 3000 A rating:
Since two insulation rings must be additionally installed per bushing terminal, a total of twelve rings are supplied.

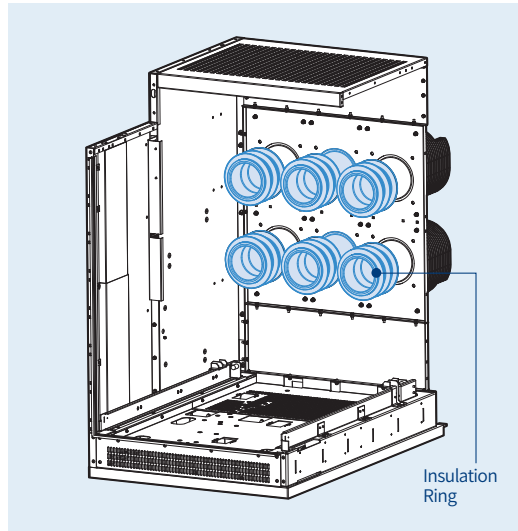

Cradle Options

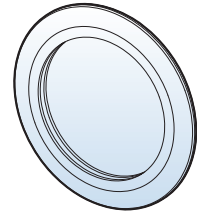

Type of handle

Manual charging handle (Only for UVH type)

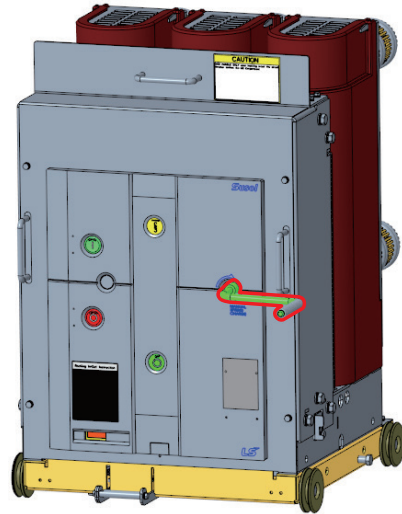

Code	Appearance
55213143046	

Racking in/out handle UVL type

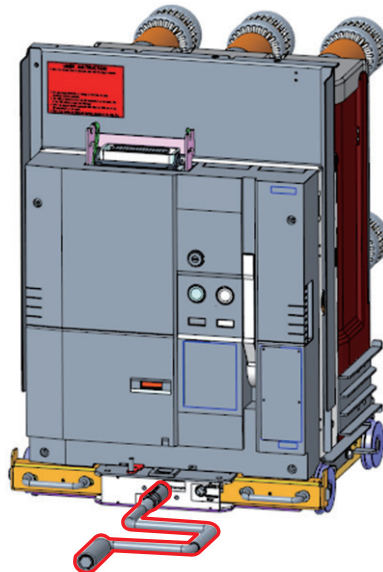

Description	Code	Appearance
Manual racking handle for UVL type	55223172407	

Note) For status (position and Open/Closed) checking and Open/Closed operation of the VCB, please contact your LSE salesperson.
(This does not apply to 38kV VCB)

Accessories

Type of handle

UVH-38H

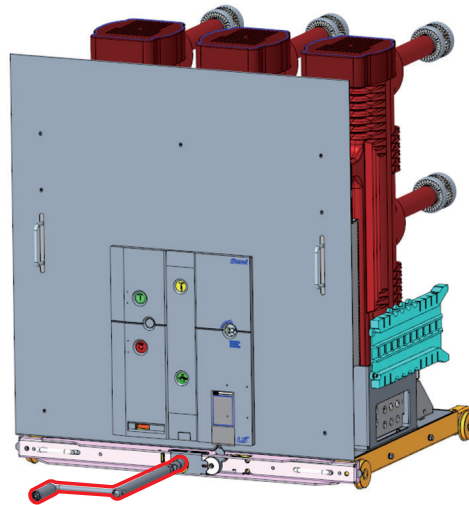

Description	Code	Appearance
Manual Racking in/out handle for 38kV UVH Type	55213163003	

UVM/UVH-05/15/27 L type

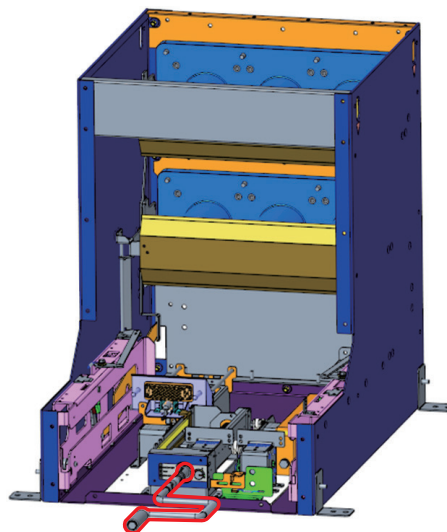

Description	Code	Appearance
Manual Racking in/out handle for L-type Cradle	55223181007	









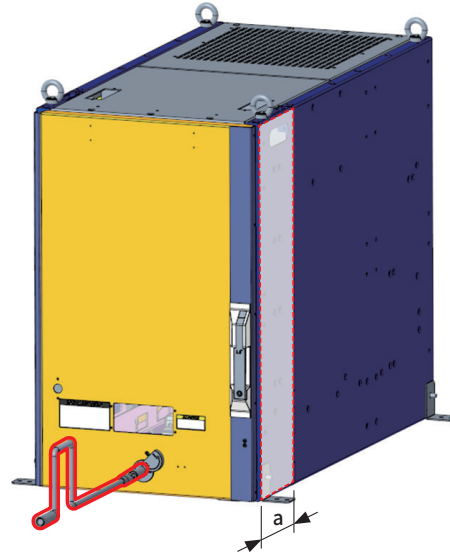



Type of handle

UVCM/UVCH-05/15/27 C,H type

- LS ELECTRIC's Susol UL VCB has two types of compartments:
 - C-type: Conventional compartment with no space between the panel door and the circuit breaker (CB).
 - H-type: New compartment type which includes a 10" space between the panel door and the CB for the LV control panel.
- Therefore, the type of compartment must be considered before choosing the racking in/out handle:
 - C-type: No space between the door and the CB.
 - H-type: A 10" space exists between the door and the CB.

** 4000A VCB is an exception and does not have the 10" space.



Compartment	Description	Code	Appearance	UVCM Series		UVCH Series								
				UVCM-05/15/27		UVCH-05/15				UVCH-27				
				Rated Current		Rated Current				Rated Current				
				1200A	2000A	1200A	2000A	3000A	4000A	1200A	2000A	2500A	2750A	
C	Racking in/out handle for manual type	55223181003			●	●	●	●	●		●	●	●	●
	Racking in/out handle for Motorized Control Racking System	55223181004			●	●	●	●	●		●	●	●	●
H	Racking in/out handle for manual type	55223181001			●	●	●	●	●		●	●	●	●
	Racking in/out handle for Motorized Control Racking System	55223181002			●	●	●	●	●		●	●	●	●
	Racking in/out handle for manual type	55223181003								●				
	Racking in/out handle for Motorized Control Racking System	55223181004								●				

Accessories

Type of extension rail

UVCM/UVCH-05/15/27 L,C,H type

- The extension rails are used to safely rack the circuit breaker (CB) in and out of the compartment.
- LS ELECTRIC's Susol UL VCB has two types of compartments:
 - C-type: Conventional compartment with no space between the panel door and the CB.
 - H-type: New compartment type which includes a 10" space between the panel door and the CB for the LV control panel.
- Therefore, the type of compartment must be considered before choosing the extension rail:
 - C-type: No space between the door and the CB.
 - H-type: A 10" space exists between the door and the CB.

** However, the 4000A VCB uses the C-type compartment's extension rail only (Part No. 59023181003).

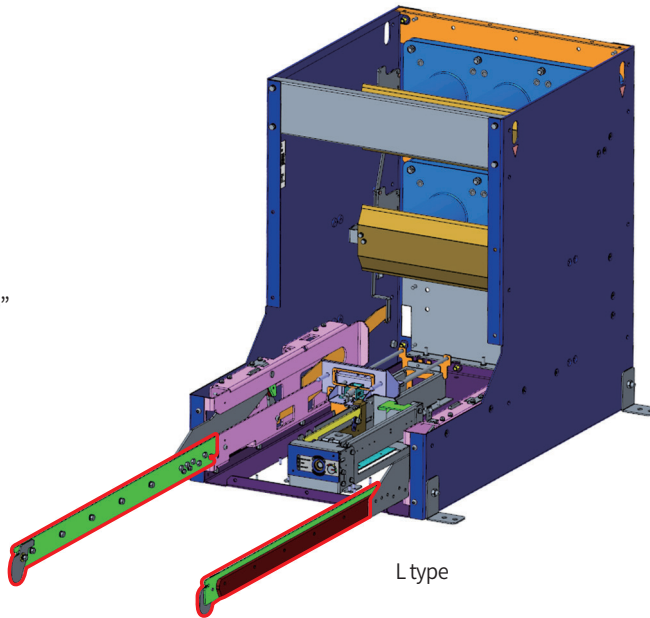

Type	Rating	Code	Appearance
L	4.76, 15 kV	59023181003	
	27 kV		

Type of extension rail

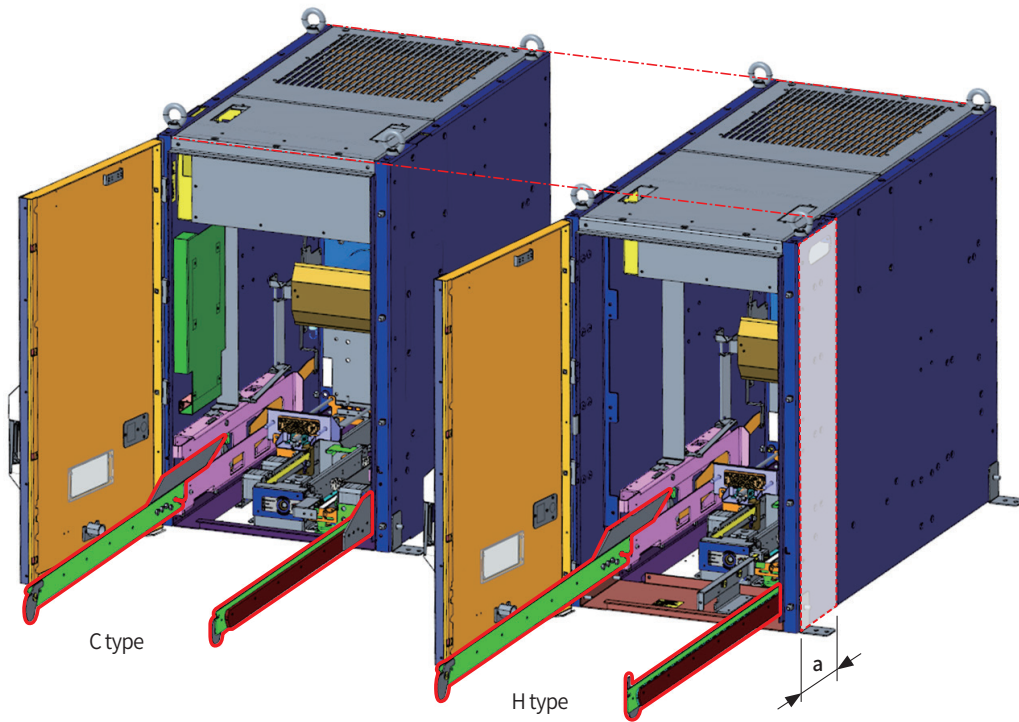

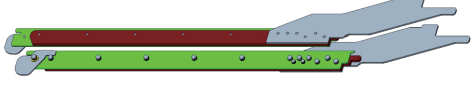
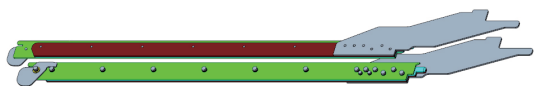
Type	Rating	Code	Appearance
C	4.76, 15 kV	59023181003	
	27 kV		
H	4.76, 15 kV	59023181009	
	27 kV		

Accessories

VCB lifting bracket set

UVH-4.76/15kV 4000A, 27kV, 38kV

- The lifting bracket set is used to lift the VCB using hoists or cranes.
- These accessories are for the Susol UL VCB 4.76/15kV 4000A and 38kV series.
- Other ratings of the Susol UL VCB include lifting eyes or eye bolts.

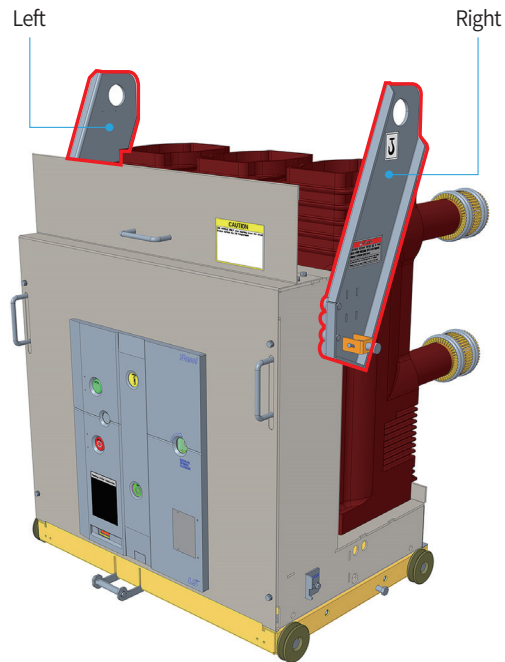

Rating	Code	Appearance
4.76/15kV 4000A	Left 75123173981	
	Right 75123173982	
27kV	Left 75123181011	
	Right 75123181010	
38kV	Left 75123173166	
	Right 75123173165	

VCB lifter

- The VCB lifter is for LS ELECTRIC's Susol UL VCB.
- The VCB lifter manually hoists the VCB to place it on the extension rail for racking in or to set it on the ground.

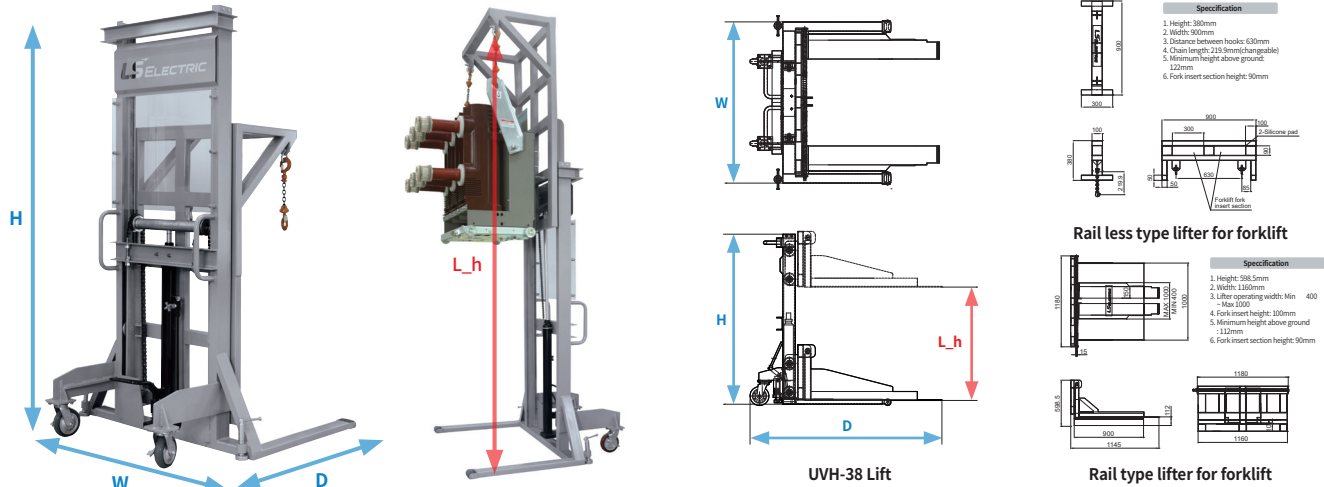

UVM/UVH-05/15 up to 3000A Lift

Ordering code	Specification	
72313181602	Size (Normal, W×D×H)	48.4"×53.1"×102.4" / 1230×1349×2600(mm)
	Maximum lift height	121.7"(3095mm)
	Maximum load weight	1102.3lb(500kg)

UVM/UVH-05/15 4000A or UVM/UVH-27 lift

Ordering code	Specification	
72313181601	Size (Normal, W×D×H)	48.4"×53.1"×96.5" / 1230×1349×2450(mm)
	Maximum lift height	131.7"(3345mm)
	Maximum load weight	1102.3lb(500kg)

UVH-38 Lift

Ordering code	Specification	
72313181603	Size (Normal, W×D×H)	50.4"×58.1"×53.2" / 1280×1475×1350(mm)
	Maximum lift height	35.4"(900mm)
	Maximum load weight	1102.3lb(500kg)
72313181071	Size (Normal, W×D×H)	50.4"×58.1"×76.8" / 1280×1475×1950(mm)
	Maximum lift height	59.1"(1500mm)
	Maximum load weight	992.1lb(450kg)

Lifter for forklift

Ordering code	Specification		Lifter type
72313181072	Size (Normal, W×D×H)	35.4"×11.8"×15.0" / 900×300×380(mm)	Rail less type lifter for forklift
	Maximum load weight	992.1lb(450kg)	
72313181073	Size (Normal, W×D×H)	45.7"×45.1"×23.6" / 1160×1145×598.5(mm)	Rail type lifter for forklift
	Maximum load weight	992.1lb(450kg)	

Accessories

Test cabinet

- The test cabinet is a device that operates “CLOSE” and “OPEN” functions when the VCB is racked out from the switchgear for maintenance or testing.
- Power supply is not provided.
- Connectors for each Susol UL VCB are provided.

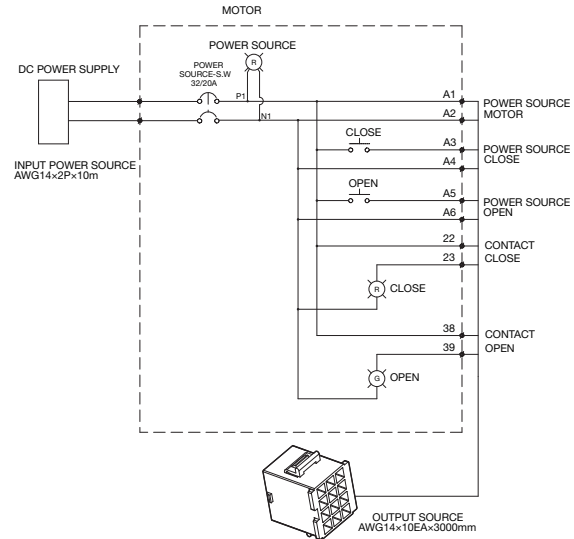
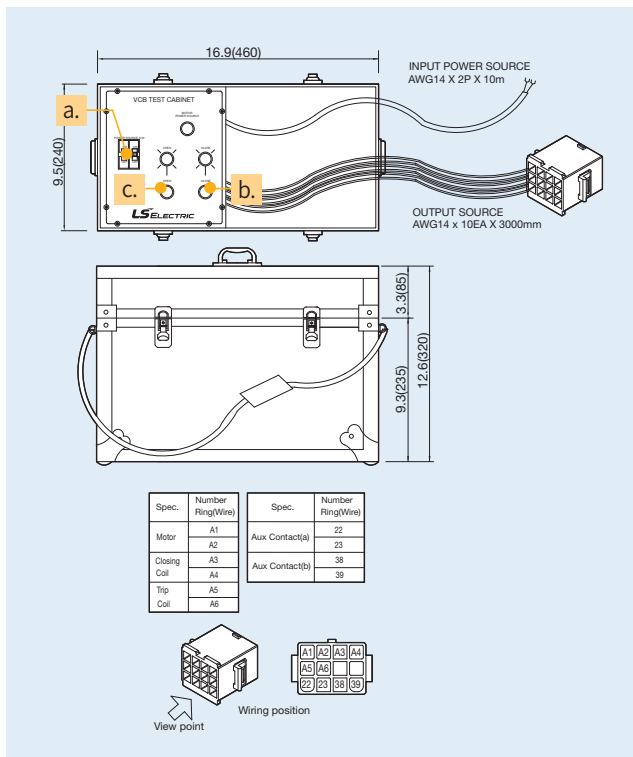

<Circuit diagram>

- a. Test Cabinet Power Switch
- b. Close Push Button
- c. Trip Open Push Button

Item code	Description
52763181005	DEVICE,VCB TEST CABINET,AC/DC 100V~AC/DC 250V,UL
52763181006	DEVICE,VCB TEST CABINET,DC24V,DC48V~60V,AC48V,UL

VCB remote control circuit diagram

UVL-05/15

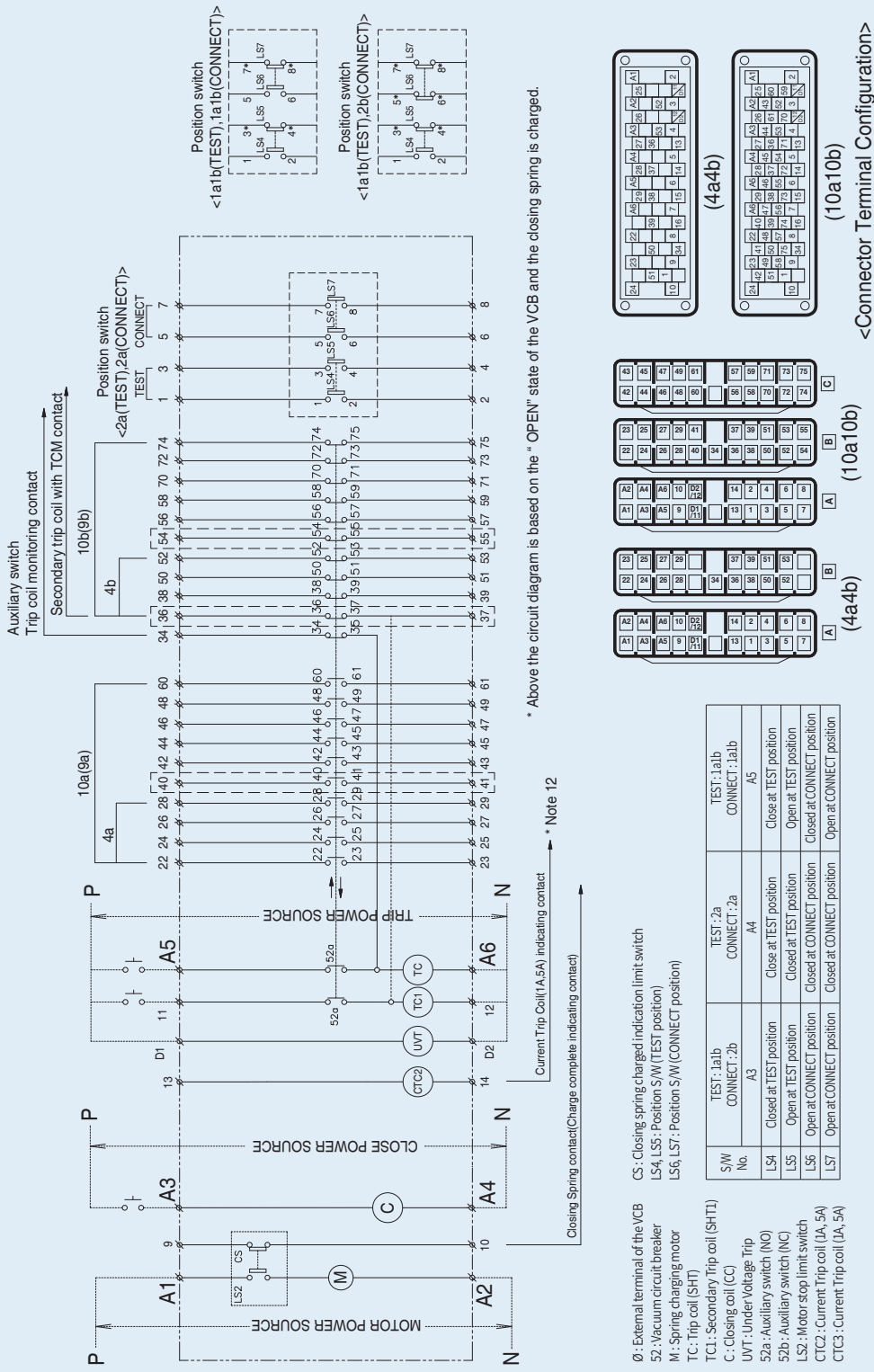

* Above the circuit diagram is based on the " OPEN " state of the VCB and the closing spring is charged.

* Note 12

S/W No.	TEST : 1a1b CONNECT : 1a1b	TEST : 2a CONNECT : 2a	TEST : 1a1b CONNECT : 1a1b
LS4	A3	A4	A5
LS5	Closed at TEST position Open at CONNECT position	Closed at TEST position Closed at CONNECT position	Close at TEST position Open at TEST position
LS6	Open at CONNECT position	Closed at CONNECT position	Closed at CONNECT position
LS7	Open at CONNECT position	Closed at CONNECT position	Open at CONNECT position

- 0 : External terminal of the VCB
- 52 : Vacuum circuit breaker
- M : Spring charging motor
- TC : Trip coil (SHT)
- TC1 : Secondary Trip coil (SHT1)
- C : Closing coil (CC)
- UVT : Under Voltage Trip
- 52a : Auxiliary switch (NO)
- LS2 : Auxiliary switch (NC)
- LS2 : Motor stop limit switch
- CTC2 : Current Trip coil (JA, 5A)
- CTC3 : Current Trip coil (JA, 5A)

- Note) 1. CTC2 : Current Trip Coil (JA, 5A) (Terminal No.: 13, 14)
 2. Positob S/W - TEST 2a, CONNECT 2a, Terminal (NO): 1, 2, 3, 4, 5, 6, 7, 8
 - TEST position 1a1b, CONNECT position 1a1b/2b are available.
 (* marked contact is b contact.)
 3. UVT - Under Voltage Trip (Terminal No.: D1, D2)
 In case TC1 is selected and auxiliary switch is 10a10b, Some 'a' contact (Terminal No.: 40, 41) and 'b' contact (Terminal No.: 54, 55) are not available
 4. TC1 - Secondary Trip Coil (Terminal No.: 11, 12)
 5. Secondary Trip coil Monitoring Contact (Terminal No.: 36)
 In case Secondary Trip Coil TCM Contact is Selected and auxiliary switch is 9a8b, Some 'a' contact (Terminal No.: 40, 41) and 'b' contact (Terminal No.: 36, 37) are not available.
 6. CTC2 - Current Trip Coil (Terminal No.: 13, 14)
 CTC3 - Current Trip Coil (Terminal No.: D1, D2)
 7. Close and Trip coil is One Pulse type, excluding Trip coil (DC110, 220V)
 8. In above optional accessories, UVT, CTC and TCI can not be selected simultaneously.

A Type
Q Type

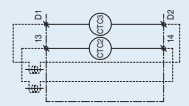
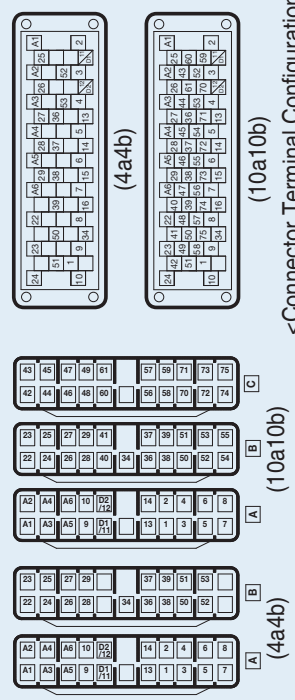

9. CTC Control Circuit

VCB remote control circuit diagram

UVM-05/15/27

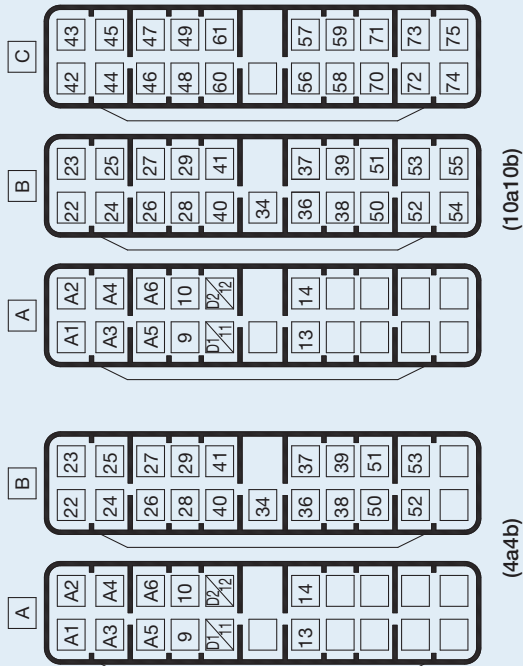
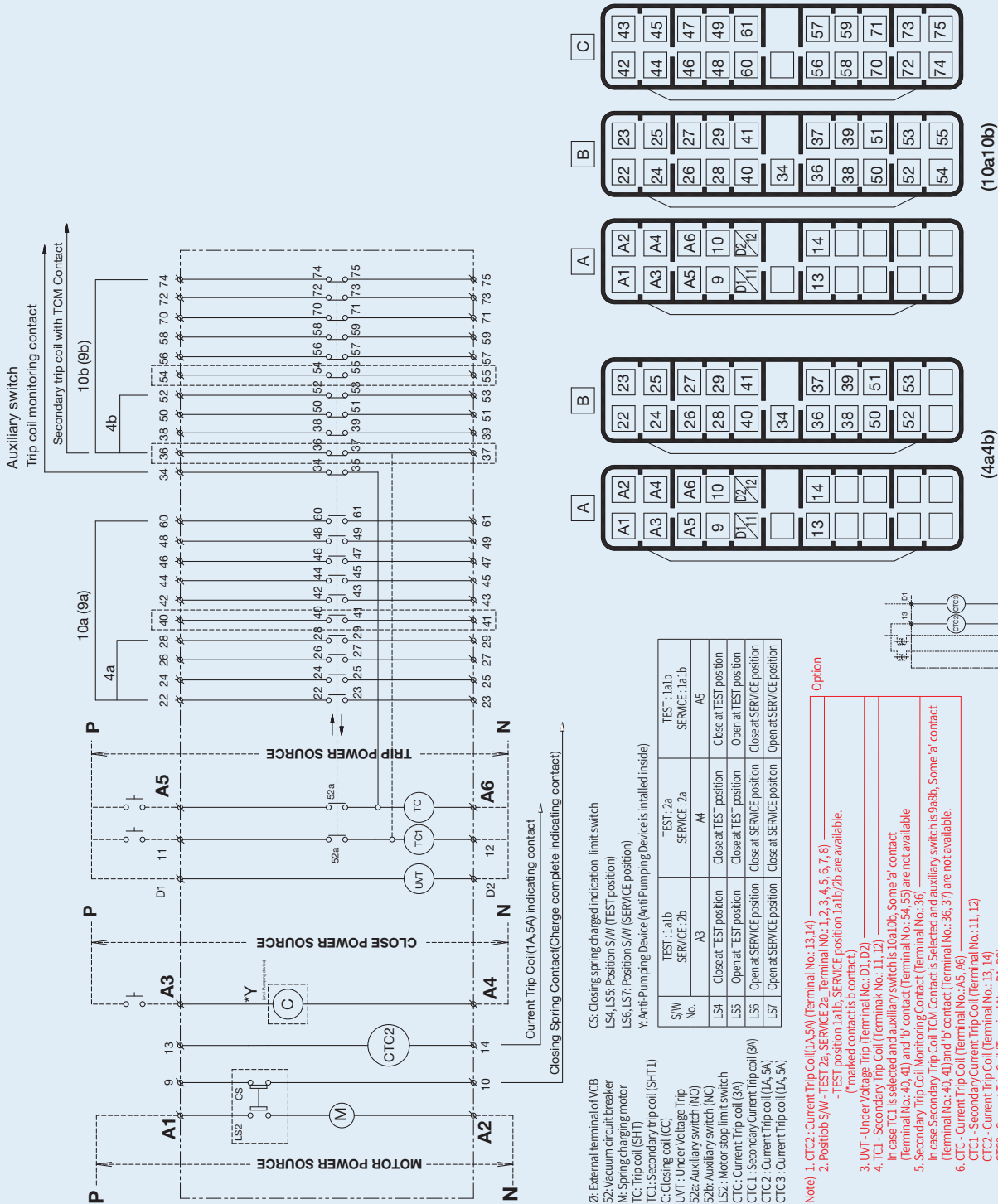

<Connector Terminal Configuration>

S/W No.	TEST : 1a1b	TEST : 2a	TEST : 1a1b	TEST : 1a1b
LS4	Close at TEST position	Close at TEST position	Close at TEST position	Close at TEST position
LS5	Open at TEST position	Open at TEST position	Open at TEST position	Open at TEST position
LS6	Open at SERVICE position	Open at SERVICE position	Open at SERVICE position	Open at SERVICE position
LS7	Open at SERVICE position	Open at SERVICE position	Open at SERVICE position	Open at SERVICE position

- Note**
- CTC2 - Current Trip Coil(LA,5A) (Terminal No.: 13,14)
 - Positob S/W - TEST 2a, SERVICE 2a, Terminal NO.: 1, 2, 3, 4, 5, 6, 7, 8
 - TEST position 1a1b, SERVICE position 1a1b/2b are available.
 (* marked contact is b contact)
 - UVT - Under Voltage Trip (Terminal No.: D1, D2)
 In case TCI is selected and auxiliary switch is 10a10b, Some 'a' contact (Terminal No.: 40, 41) and 'b' contact (Terminal No.: 54, 55) are not available
 - Secondary Trip Coil Monitoring Contact (Terminal No.: 36)
 In case Secondary Trip Coil TCM Contact is Selected and auxiliary switch is 9a8b, Some 'a' contact (Terminal No.: 40, 41) and 'b' contact (Terminal No.: 36, 37) are not available.
 - CTC - Current Trip Coil (Terminal No.: A5, A6)
 CTC1 - Secondary Current Trip Coil (Terminal No.: 11, 12)
 CTC2 - Current Trip Coil (Terminal No.: 13, 14)
 CTC3 - Current Trip Coil (Terminal No.: D1, D2)
 - Close and Trip coil is One Pulse type, excluding Trip coil (DC24, DC48, DC110, 220V)
 - In above optional accessories, UVT, CTC and TCI can not be selected simultaneously
 - Above circuit diagram is based on 'Closed' state of VCB and closing spring is charged.

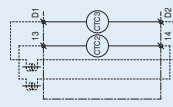

10. CTC Control Circuit

UVM-05/15/27

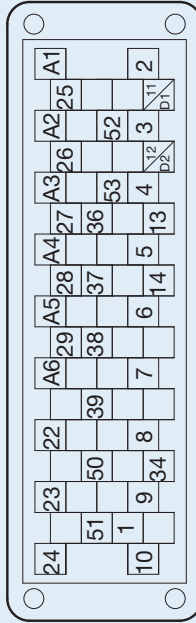
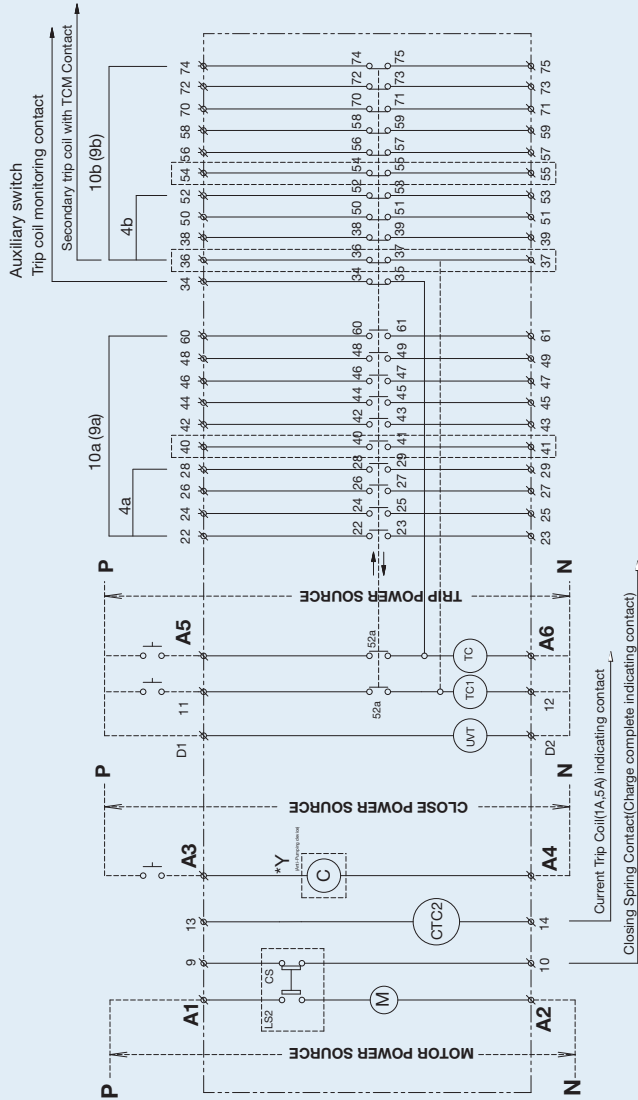

(4a4b)

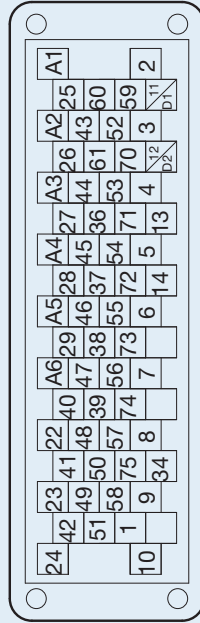

(10a10b)

<Connector Terminal Configuration>

S/W No.	TEST - 1a:1b SERVICE - 1a:1b	TEST - 2a SERVICE - 2a	TEST - 1a:1b SERVICE - 1a:1b
LS4	Close at TEST position	Close at TEST position	Close at TEST position
LS5	Open at TEST position	Open at TEST position	Open at TEST position
LS6	Open at SERVICE position	Close at SERVICE position	Close at SERVICE position
LST	Open at SERVICE position	Close at SERVICE position	Open at SERVICE position

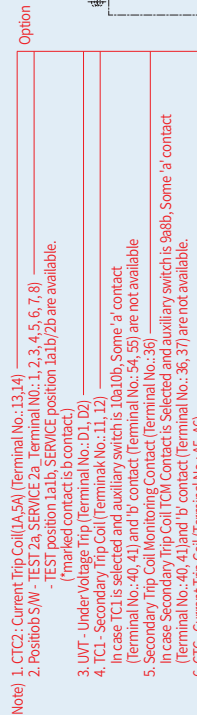

10. CTC Control Circuit

- Ø: External terminal of VCB
- S2: Vacuum circuit breaker
- M: Spring charging motor
- TC: Trip coil (SHT)
- TC1: Secondary Trip coil (SHT1)
- C: Closing coil (CC)
- UVT: Under Voltage Trip
- S2a: Auxiliary switch (NO)
- S2b: Auxiliary switch (NC)
- LS2: Motor stop limit switch
- CTC: Current Trip coil(3A)
- CTC1: Secondary Current Trip coil(3A)
- CTC2: Current Trip coil (1A, 5A)
- CTC3: Current Trip coil (1A, 5A)

- Note 1. CTC2: Current Trip Coil(1A,5A) (Terminal No.:13,14)
- 2. Position S/W - TEST 2a, SERVICE 2a; Terminal NO.: 1, 2, 3, 4, 5, 6, 7, 8) - TEST position 1a:1b, SERVICE position 1a:1b/2b are available. (marked contacts b contact)
- 3. UVT - Under Voltage Trip (Terminal No.: D1, D2)
- 4. TC1 - Secondary Trip Coil (Terminal No.: 11, 12) In case TC1 is selected and auxiliary switch is 10a10b, Some 'a' contact (Terminal No.: 40, 41) and 'b' contact (Terminal No.: 54, 55) are not available
- 5. Secondary Trip Coil Monitoring Contact (Terminal No.: 36) In case Secondary Trip Coil TCM Contact Selected and auxiliary switch is 9a8b, Some 'a' contact (Terminal No.: 40, 41) and 'b' contact (Terminal No.: 36, 37) are not available.
- 6. CTC - Current Trip Coil (Terminal No.: A5, A6)
- CTC1 - Secondary Current Trip Coil (Terminal No.: 13, 14)
- CTC2 - Current Trip Coil (Terminal No.: 13, 14)
- CTC3 - Current Trip Coil (Terminal No.: D1, D2)
- 7. Close and Trip coil is One Pulse type, excluding Trip coil (DC24, DC48, DC110, 220V)
- 8. In above optional accessories, UVT, CTC and TCI can not be selected simultaneously.
- 9. Above circuit diagram is based on "Closed" state of VCB and closing spring is charged.

VCB remote control circuit diagram

UVH-05/15/27

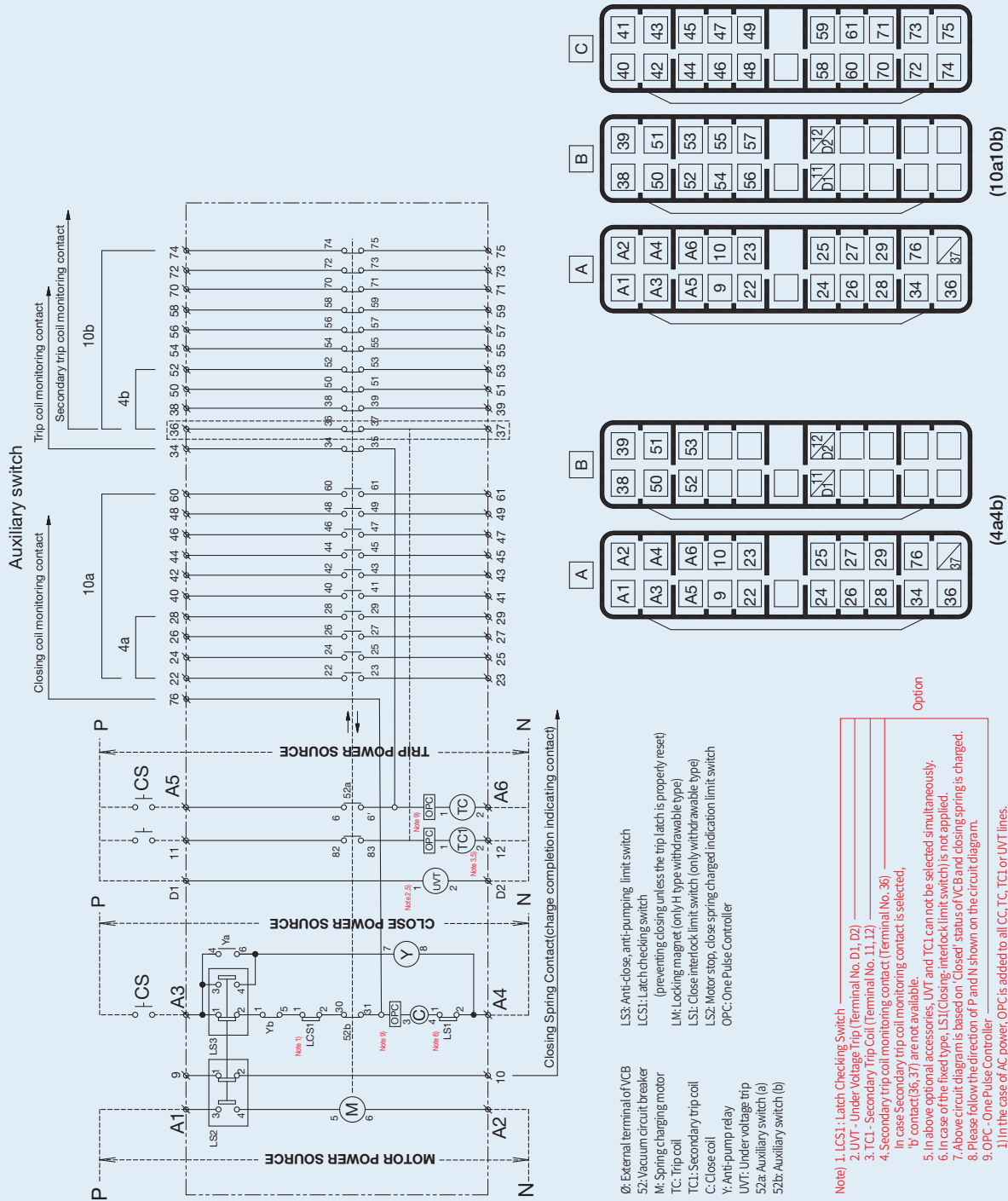

<Connector Terminal Configuration>

- Note:**
- LCS1: Latch Checking Switch
 - UVT: Under Voltage Trip (Terminal No. D1, D2)
 - TC1: Secondary Trip Coil (Terminal No. 11, 12)
 - Secondary trip coil monitoring contact (Terminal No. 36)
 - In case secondary trip coil monitoring contact is selected, 'b' contact (36, 37) are not available.
 - In above optional accessories, UVT and TC1 can not be selected simultaneously.
 - In case of the fixed type, LS1 (Closing interlock limit switch) is not applied.
 - Above circuit diagram is based on 'Closed' status of VCB Band closing spring is charged.
 - Please follow the direction of P and N shown on the circuit diagram.
 - OPC: One Pulse Controller
 - 1) In the case of AC power, OPC is added to all CC, TC, TCI or UVT lines. Due to the resistance of the controller, Close & Trip Coil Monitoring is not possible.
 - 2) In the case of DC power, OPC is added to the CC line only when the Keylock option is added. At this time, Close Coil Monitoring is not possible.

UVH-05/15/27

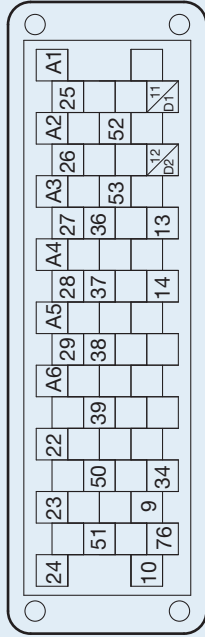
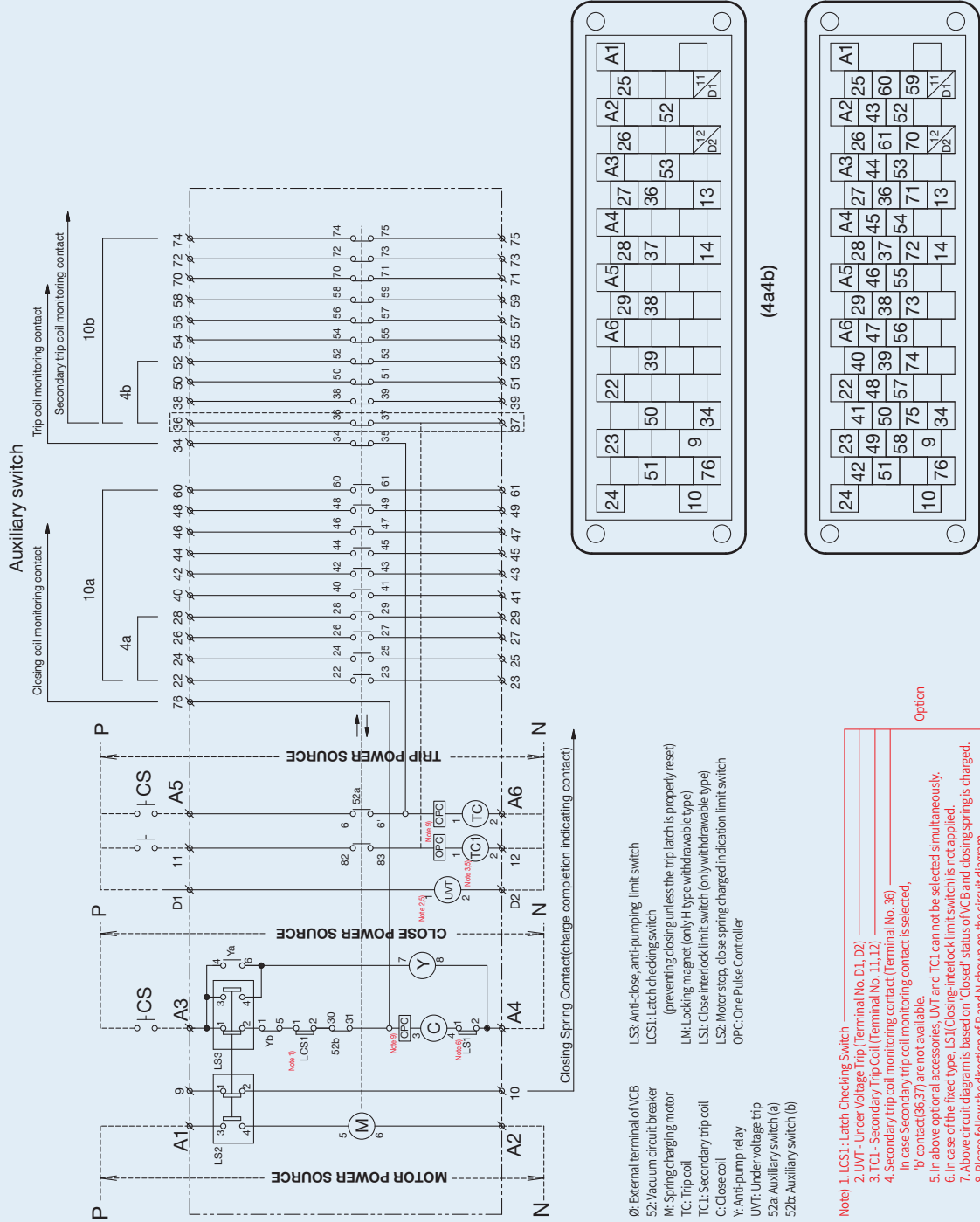

(4a4b)

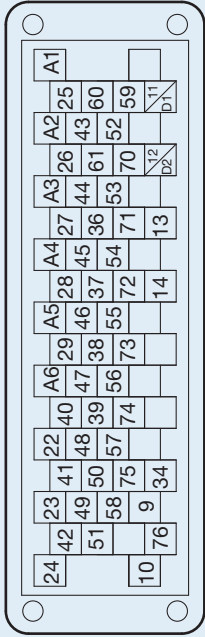

(10a10b)

<Connector Terminal Configuration>

- Ø: External terminal of VCB
- M: Vacuum circuit breaker
- M: Spring charging motor
- TC: Trip coil
- TC1: Secondary trip coil
- C: Close coil
- Y: Anti-pump relay
- UVT: Under voltage trip
- 52a: Auxiliary switch (a)
- 52b: Auxiliary switch (b)
- LS3: Anti-close, anti-pumping limit switch
- LCS1: Latch checking switch (preventing closing unless the trip latch is properly reset)
- LM: Locking magnet (only H type withdrawable type)
- LS1: Close interlock limit switch (only withdrawable type)
- LS2: Motor stop, close spring charged indication limit switch
- OPC: One Pulse Controller

Note

1. LCS1: Latch Checking Switch
2. UVT: Under Voltage Trip (Terminal No. D1, D2)
3. TC1: Secondary Trip Coil (Terminal No. 11, 12)
4. Secondary trip coil monitoring contact (Terminal No. 36)
in case secondary trip coil monitoring contact is selected, 'b' contact(36/37) are not available
5. in above optional accessories, UVT and TC1 can not be selected simultaneously.
6. in case of the fixed type, LS1(Closing interlock limit switch) is not applied.
7. Above circuit diagram is based on 'Closed' status of VCB and closing spring is charged.
8. Please follow the direction of P and N shown on the circuit diagram.
9. OPC - One Pulse Controller
1) In the case of AC power, OPC is added to all CC, TC, TC1 or UVT lines.
Due to the resistance of the controller, Close & Trip Coil Monitoring is not possible.
2) In the case of DC power, OPC is added to the CC line only when the Keylock option is added. At this time, Close Coil Monitoring is not possible.

VCB remote control circuit diagram

UVH-38

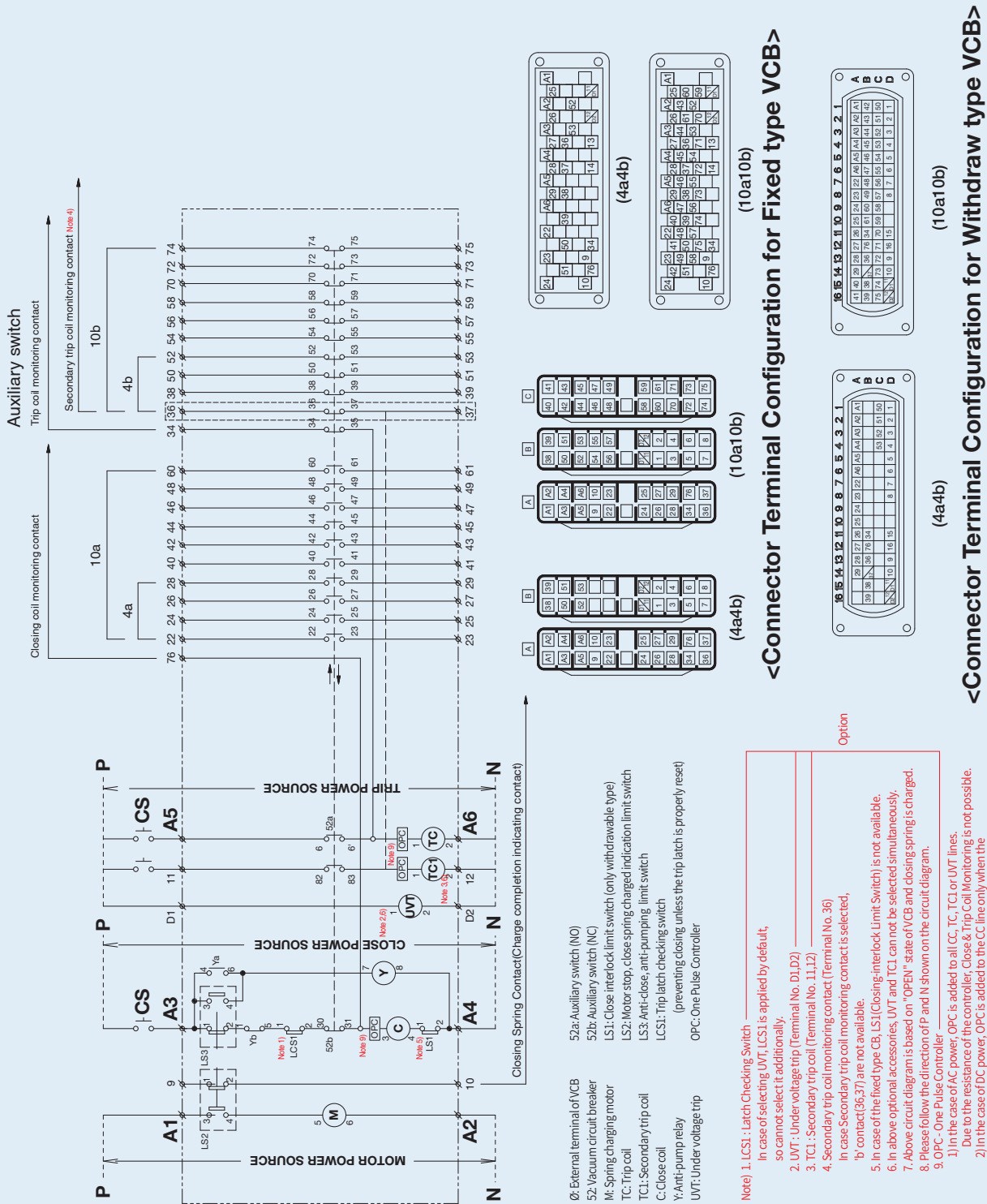

Specification

UVL-Type (4.76kV)

Designation			UVL type			
			UVL-05□25□12	UVL-05□52□20	UVL-05□32□12	UVL-05□32□20
Rated voltage	Ur (kV)	4.76				
Rated current	Ir (A)	1200	2000	1200	2000	
Pole distance	(mm)	5.9" (150mm) / 8.27" (210mm)	8.27" (210mm)	5.9" (150mm) / 8.27" (210mm)	8.27" (210mm)	
Rated frequency	fr (Hz)	60				
Rated interrupting current	Ik (kA)	25		31.5		
Rated interrupting capacity	(MVA)	203		260		
Rated short-time current	Ik/tk (kA)	25 / 3s		31.5 / 3s		
Rated making current	Ip (kA)	65		81.9		
Rated interrupting time	(cycle)	3				
Withstand Voltage	Frequency	Ud (kV)	19			
	Impulse	Up (kV/1.2×50μs)	60			
Operating duty		O-0.3s-CO-15s-CO				
Motor	Control voltage	(V)	DC24~30V, DC48~60V, DC125V, DC200~250V, AC48V, AC110~130V, AC200~250V			
Closing coil	Control voltage	(V)	DC24~30V, DC48~60V, DC125V, DC200~250V, AC48V, AC110~130V, AC200~250V			
Trip coil	Control voltage	(V)	DC24~30V, DC48~60V, DC125V, DC200~250V, AC48V, AC110~130V, AC200~250V			
UVT coil	Control voltage	(V)	DC24~30V, DC48~60V, DC125V, DC200~250V, AC48V, AC110~130V, AC200~250V			
Standard aux. contacts	Type		4a4b, 10a10b			
	Rated continuous current		DC 10A			
	Breaking capacity		600W			
	Endurance (Operations) (Mechanical, Interrupting)		10000 times			
Rated opening time	(S)	≤ 0.04				
No-load closing time	(S)	≤ 0.06				
Mechanical endurance	(Operations)	M2 (10000 times)				
VI (Vacuum interrupter) type		LV6	LV6A	LV6	LV6A	
Electrical endurance		Reference standard				
Capacitive current switching		C2				
Operating temperature	Low	-30°C				
	High	40°C				
Life time	Electrical	(Operations)	Reference electrical life graph			
Installation	Fixed	H, P type				
Applicable standard	IEEE Std C37.09, ANSI C37.54					
UL Certificate	UL Listed					

Technical data

Specification

UVL-Type (15kV)

Designation			UVL type			
			UVL-15□25□12	UVL-15□25□20	UVL-15□32□12	UVL-15□32□20
Rated voltage	Ur (kV)	15				
Rated current	Ir (A)	1200	2000	1200	2000	
Pole distance	(mm)	5.9" (150mm) / 8.27" (210mm)	8.27" (210mm)	5.9" (150mm) / 8.27" (210mm)	8.27" (210mm)	
Rated frequency	fr (Hz)	60				
Rated interrupting current	Ik (kA)	25		31.5		
Rated interrupting capacity	(MVA)	650		820		
Rated short-time current	Ik/tk (kA)	25 / 3s		31.5 / 3s		
Rated making current	Ip (kA)	65		81.9		
Rated interrupting time	(cycle)	3				
Withstand Voltage	Frequency	Ud (kV)	36			
	Impulse	Up (kV/1.2×50μs)	95			
Operating duty	O-0.3s-CO-15s-CO					
Motor	Control voltage	(V)	DC24~30V, DC48~60V, DC125V, DC200~250V, AC48V, AC110~130V, AC200~250V			
Closing coil	Control voltage	(V)	DC24~30V, DC48~60V, DC125V, DC200~250V, AC48V, AC110~130V, AC200~250V			
Trip coil	Control voltage	(V)	DC24~30V, DC48~60V, DC125V, DC200~250V, AC48V, AC110~130V, AC200~250V			
UVT coil	Control voltage	(V)	DC24~30V, DC48~60V, DC125V, DC200~250V, AC48V, AC110~130V, AC200~250V			
Standard aux. contacts	Type	4a4b, 10a10b				
	Rated continuous current	DC 10A				
	Breaking capacity	600W				
	Endurance (Operations) (Mechanical, Interrupting)	10000 times				
Rated opening time	(S)	≤ 0.04				
No-load closing time	(S)	≤ 0.06				
Mechanical endurance	(Operations)	M2 (10000 times)				
VI(Vacuum interrupter) type	LV6 LV6A LV6 LV6A					
Electrical endurance	Reference standard					
Capacitive current switching	C2					
Operating temperature	Low	-30°C				
	High	40°C				
Life time	Electrical	(Operations)	Reference electrical life graph			
Installation	Fixed	H, P type				
Applicable standard	IEEE Std C37.09, ANSI C37.54					
UL Certificate	UL Listed					

UVL-Type (27kV)

Designation			UVL type
			UVL-27P32C20
Rated voltage	Ur (kV)		27
Rated current	Ir (A)		1200
Pole distance	(mm)		10" (254mm)
Rated frequency	fr (Hz)		60
Rated interrupting current	Ik (kA)		25
Rated interrupting capacity	(MVA)		1170
Rated short-time current	Ik/tk (kA)		25 / 3s
Rated making current	Ip (kA)		65
Rated interrupting time	(cycle)		3
Withstand Voltage	Frequency	Ud (kV)	60
	Impulse	Up (kV/1.2×50μs)	125
Operating duty			O-0.3s-CO-15s-CO
Motor	Control voltage	(V)	DC24~30V, DC48~60V, DC125V, DC200~250V, AC48V, AC110~130V, AC200~250V
Closing coil	Control voltage	(V)	DC24~30V, DC48~60V, DC125V, DC200~250V, AC48V, AC110~130V, AC200~250V
Trip coil	Control voltage	(V)	DC24~30V, DC48~60V, DC125V, DC200~250V, AC48V, AC110~130V, AC200~250V
UVT coil	Control voltage	(V)	DC24~30V, DC48~60V, DC125V, DC200~250V, AC48V, AC110~130V, AC200~250V
Standard aux. contacts	Type		4a4b, 10a10b
	Rated continuous current		DC 10A
	Breaking capacity		600W
	Endurance (Operations) (Mechanical, Interrupting)		10000 times
Rated opening time	(S)		≤ 0.04
No-load closing time	(S)		≤ 0.07
Mechanical endurance	(Operations)		M2 (10000 times)
VI(Vacuum interrupter) type			LV14-P1
Electrical endurance			Reference standard
Capacitive current switching			C2
Operating temperature	Low		-30°C
	High		40°C
Life time	Electrical	(Operations)	Reference electrical life graph
Installation	Fixed		P type
Applicable standard			IEEE Std C37.09
UL Certificate			ANSI type test

Technical data

Specification

UVM-Type (4.76kV)

Designation			UVM type			
			UVM-05□25□12	UVM-05□52□20	UVM-05□32□12	UVM-05□32□20
Rated voltage	Ur (kV)	4.76				
Rated current	Ir (A)	1200	2000	1200	2000	
Pole distance	(mm)	7" (178mm) / 10" (254mm)				
Rated frequency	fr (Hz)	60				
Rated interrupting current	Ik (kA)	25		31.5		
Rated interrupting capacity	(MVA)	206		260		
Rated short-time current	Ik/tk (kA)	25 / 3s		31.5 / 3s		
Rated making current	Ip (kA)	65		81.9		
Rated interrupting time	(cycle)	3				
Withstand Voltage	Frequency	Ud (kV)	19			
	Impulse	Up (kV/1.2×50μs)	60			
Operating duty		O-0.3s-CO-15s-CO				
Motor	Control voltage	(V)	DC24~30V, DC48~60V, DC125V, DC200~250V, AC48V, AC110~130V, AC200~250V			
Closing coil	Control voltage	(V)	DC24~30V, DC48~60V, DC125V, DC200~250V, AC48V, AC110~130V, AC200~250V			
Trip coil	Control voltage	(V)	DC24~30V, DC48~60V, DC125V, DC200~250V, AC48V, AC110~130V, AC200~250V			
UVT coil	Control voltage	(V)	DC24~30V, DC48~60V, DC125V, DC200~250V, AC48V, AC110~130V, AC200~250V			
Standard aux. contacts	Type		4a4b, 10a10b			
	Rated continuous current		DC 10A			
	Breaking capacity		600W			
	Endurance (Operations) (Mechanical, Interrupting)		10000 times			
Rated opening time	(S)	≤ 0.04				
No-load closing time	(S)	≤ 0.06				
Mechanical endurance	(Operations)	M2 (10000 times)				
VI(Vacuum interrupter) type		LV5	LV6A	LV6	LV6A	
Electrical endurance		Reference standard				
Capacitive current switching		C2				
Operating temperature	Low	-30°C				
	High	40°C				
Life time	Electrical	(Operations)	Reference electrical life graph			
Installation	Fixed		H, P type			
Applicable standard		IEEE Std C37.09, ANSI C37.54				
UL Certificate		UL Listed				

UVM-Type (15kV)

Designation			UVM type			
			UVM-15□25□12	UVM-15□25□20	UVM-15□32□12	UVM-15□32□20
Rated voltage	Ur (kV)	15				
Rated current	Ir (A)	1200	2000	1200	2000	
Pole distance	(mm)	7" (178mm) / 10" (254mm)				
Rated frequency	fr (Hz)	60				
Rated interrupting current	Ik (kA)	25		31.5		
Rated interrupting capacity	(MVA)	650		820		
Rated short-time current	Ik/tk (kA)	25 / 3s		31.5 / 3s		
Rated making current	Ip (kA)	65		81.9		
Rated interrupting time	(cycle)	3				
Withstand Voltage	Frequency	Ud (kV)	36			
	Impulse	Up (kV/1.2×50μs)	95			
Operating duty	O-0.3s-CO-15s-CO					
Motor	Control voltage	(V)	DC24~30V, DC48~60V, DC125V, DC200~250V, AC48V, AC110~130V, AC200~250V			
Closing coil	Control voltage	(V)	DC24~30V, DC48~60V, DC125V, DC200~250V, AC48V, AC110~130V, AC200~250V			
Trip coil	Control voltage	(V)	DC24~30V, DC48~60V, DC125V, DC200~250V, AC48V, AC110~130V, AC200~250V			
UVT coil	Control voltage	(V)	DC24~30V, DC48~60V, DC125V, DC200~250V, AC48V, AC110~130V, AC200~250V			
Standard aux. contacts	Type	4a4b, 10a10b				
	Rated continuous current	DC 10A				
	Breaking capacity	600W				
	Endurance (Operations) (Mechanical, Interrupting)	10000 times				
Rated opening time	(S)	≤ 0.04				
No-load closing time	(S)	≤ 0.06				
Mechanical endurance	(Operations)	M2 (10000 times)				
VI (Vacuum interrupter) type		LV5	LV6A	LV6	LV6A	
Electrical endurance	Reference standard					
Capacitive current switching	C2					
Operating temperature	Low	-30°C				
	High	40°C				
Life time	Electrical	(Operations)	Reference electrical life graph			
Installation	Fixed	H, P type				
Applicable standard	IEEE Std C37.09, ANSI C37.54					
UL Certificate	UL Listed					

Technical data

Specification

UVH-Type (4.76kV)

Designation			UVH type					
			UVH-05□40□12	UVH-05□40□20	UVH-05□50□12	UVH-05□50□20	UVH-05□25,32,40,50C30	UVH-05□25,32,40,50L40
Rated voltage	Ur (kV)		4.76					
Rated current	Ir (A)		1200	2000	1200	2000	3000	4000
Pole distance	(mm)		7" (178mm) / 10" (254mm)			10" (254mm)	12.6" (320mm)	
Rated frequency	fr (Hz)		60					
Rated interrupting current	Ik (kA)		40		50		25 / 31.5 / 40 / 50	25 / 31.5 / 40 / 50
Rated interrupting capacity	(MVA)		330		410		206 / 260 / 330 / 410	206 / 260 / 330 / 410
Rated short-time current	Ik/tk (kA)		25 / 3s		31.5 / 3s		25 / 3s, 31.5 / 3s, 40 / 3s, 50 / 3s	25 / 3s, 31.5 / 3s, 40 / 3s, 50 / 3s
Rated making current	Ip (kA)		104		130		65 / 81.9 / 104 / 130	65 / 81.9 / 104 / 130
Rated interrupting time	(cycle)		3					
Withstand Voltage	Frequency	Ud (kV)	19					
	Impulse	Up (kV/1.2×50μs)	60					
Operating duty			O-0.3s-CO-15s-CO					
Motor	Control voltage	(V)	DC48~60V, DC125V, DC200~250V, AC48V, AC110~130V, AC200~250V					
Closing coil	Control voltage	(V)	DC48~60V, DC125V, DC200~250V, AC48V, AC110~130V, AC200~250V					
Trip coil	Control voltage	(V)	DC48~60V, DC125V, DC200~250V, AC48V, AC110~130V, AC200~250V					
UVT coil	Control voltage	(V)	DC48~60V, DC125V, DC200~250V, AC48V, AC110~130V, AC200~250V					
Standard aux. contacts	Type		4a4b, 10a10b					
	Rated continuous current		DC 10A					
	Breaking capacity		600W					
	Endurance (Operations) (Mechanical, Interrupting)		10000 times					
Rated opening time	(S)		≤ 0.04					
No-load closing time	(S)		≤ 0.06					
Mechanical endurance	(Operations)		M2 (10000 times)					
VI(Vacuum interrupter) type			LV10		LV8		LV8	LV8
Electrical endurance			Reference standard					
Capacitive current switching			C2					
Operating temperature	Low		-30°C					
	High		40°C					
Life time	Electrical	(Operations)	Reference electrical life graph					
Installation	Fixed		H, P type					
Applicable standard			IEEE Std C37.09, ANSI C37.54					
UL Certificate			UL Listed					

UVH-Type (15kV)

Designation			UVH type					
			UVH-15□40□12	UVH-15□40□20	UVH-15□50□12	UVH-15□50□20	UVH-15□25,32,40,50□30	UVH-15□25,32,40,50□40
Rated voltage	Ur (kV)		15					
Rated current	Ir (A)		1200	2000	1200	2000	3000	4000
Pole distance	(mm)		7" (178mm) / 10" (254mm)			10" (254mm)	12.6" (320mm)	
Rated frequency	fr (Hz)		60					
Rated interrupting current	Ik (kA)		40		50		25 / 31.5 / 40 / 50	25 / 31.5 / 40 / 50
Rated interrupting capacity	(MVA)		1040		1300		650/820/1040/1300	650/820/1040/1300
Rated short-time current	Ik/tk (kA)		25 / 3s		31.5 / 3s		25 / 3s, 31.5 / 3s, 40 / 3s, 50 / 3s	25 / 3s, 31.5 / 3s, 40 / 3s, 50 / 3s
Rated making current	Ip (kA)		104		130		65 / 81.9 / 104 / 130	65 / 81.9 / 104 / 130
Rated interrupting time	(cycle)		3					
Withstand Voltage	Frequency	Ud (kV)	36					
	Impulse	Up (kV/1.2×50μs)	95					
Operating duty			O-0.3s-CO-15s-CO					
Motor	Control voltage	(V)	DC48~60V, DC125V, DC200~250V, AC48V, AC110~130V, AC200~250V					
Closing coil	Control voltage	(V)	DC48~60V, DC125V, DC200~250V, AC48V, AC110~130V, AC200~250V					
Trip coil	Control voltage	(V)	DC48~60V, DC125V, DC200~250V, AC48V, AC110~130V, AC200~250V					
UVT coil	Control voltage	(V)	DC48~60V, DC125V, DC200~250V, AC48V, AC110~130V, AC200~250V					
Standard aux. contacts	Type		4a4b, 10a10b					
	Rated continuous current		DC 10A					
	Breaking capacity		600W					
	Endurance (Operations) (Mechanical, Interrupting)		10000 times					
Rated opening time	(S)		≤ 0.04					
No-load closing time	(S)		≤ 0.06					
Mechanical endurance	(Operations)		M2 (10000 times)					
VI(Vacuum interrupter) type			LV10		LV8		LV8	LV8
Electrical endurance			Reference standard					
Capacitive current switching			C2					
Operating temperature	Low		-30°C					
	High		40°C					
Life time	Electrical	(Operations)	Reference electrical life graph					
Installation	Fixed		H, P type					
Applicable standard			IEEE Std C37.09, ANSI C37.54					
UL Certificate			UL Listed					

Technical data

Specification

UVH-Type (27kV)

Designation			UVH type					
			UVH-27□25C25	UVH-27□25C28	UVH-27□32,40C12	UVH-27□32,40C20	UVH-27□32,40C25	UVH-27□32,40C28
Rated voltage	Ur (kV)		27					
Rated current	Ir (A)		2500	2750	1200	2000	2500	2750
Pole distance	(mm)		10" (254mm) 10" (254mm)					
Rated frequency	fr (Hz)		60					
Rated interrupting current	Ik (kA)		25			31.5/40		
Rated interrupting capacity	(MVA)		1169			1473/1871		
Rated short-time current	Ik/tk (kA)		25/3s			31.5/3s, 40/3s		
Rated making current	Ip (kA)		65			81.9/104		
Rated interrupting time	(cycle)		3					
Withstand Voltage	Frequency	Ud (kV)	60					
	Impulse	Up (kV/1.2×50μs)	125					
Operating duty			O-0.3s-CO-15s-CO					
Motor	Control voltage	(V)	DC48~60V, DC125V, DC200~250V, AC48V, AC110~130V, AC200~250V					
Closing coil	Control voltage	(V)	DC48~60V, DC125V, DC200~250V, AC48V, AC110~130V, AC200~250V					
Trip coil	Control voltage	(V)	DC48~60V, DC125V, DC200~250V, AC48V, AC110~130V, AC200~250V					
UVT coil	Control voltage	(V)	DC48~60V, DC125V, DC200~250V, AC48V, AC110~130V, AC200~250V					
Standard aux. contacts	Type		4a4b, 10a10b					
	Rated continuous current		DC 10A					
	Breaking capacity		600W					
	Endurance (Operations) (Mechanical, Interrupting)		10000 times					
Rated opening time	(S)		≤ 0.04					
No-load closing time	(S)		≤ 0.06					
Mechanical endurance	(Operations)		M2 (10000 times)					
VI(Vacuum interrupter) type			LV7-P1					
Electrical endurance			Reference standard					
Capacitive current switching			C2					
Operating temperature	Low		-30°C					
	High		40°C					
Life time	Electrical	(Operations)	Reference electrical life graph					
Installation	Fixed		H, P type					
Applicable standard			IEEE Std C37.09, ANSI C37.54					
UL Certificate			UL Listed					

UVH-Type (38kV)

Designation			UVH type		
			UVH-38□32,40E12	UVH-38□32,40E20	UVH-38□32,40E30
Rated voltage	Ur (kV)		38		
Rated current	Ir (A)		1200	2000	3000
Pole distance	(mm)		11.8" (300mm)		
Rated frequency	fr (Hz)		60		
Rated interrupting current	Ik (kA)		31.5 / 40		
Rated interrupting capacity	(MVA)		2074 / 2633		
Rated short-time current	Ik/tk (kA)		31.5 / 3s, 40 / 3s		
Rated making current	Ip (kA)		81.9 / 104		
Rated interrupting time	(cycle)		3		
Withstand Voltage	Frequency	Ud (kV)	80		
	Impulse	Up (kV/1.2×50μs)	170		
Operating duty			O-0.3s-CO-15s-CO		
Motor	Control voltage	(V)	DC48~60V, DC110V, DC125V, DC200~250V, AC48V, AC110~130V, AC200~250V		
Closing coil	Control voltage	(V)	DC48~60V, DC110V, DC125V, DC200~250V, AC48V, AC110~130V, AC200~250V		
Trip coil	Control voltage	(V)	DC48~60V, DC110V, DC125V, DC200~250V, AC48V, AC110~130V, AC200~250V		
UVT coil	Control voltage	(V)	DC48~60V, DC110V, DC125V, DC200~250V, AC48V, AC110~130V, AC200~250V		
Standard aux. contacts	Type		4a4b, 10a10b		
	Rated continuous current		DC 10A		
	Breaking capacity		600W		
	Endurance (Operations) (Mechanical, Interrupting)		10000 times		
Rated opening time		(S)	≤ 0.04		
No-load closing time		(S)	≤ 0.06		
Mechanical endurance		(Operations)	M2 (10000 times)		
VI(Vacuum interrupter) type			LV8-P		
Electrical endurance			Reference standard		
Capacitive current switching			C2		
Operating temperature	Low		-30°C		
	High		40°C		
Life time	Electrical	(Operations)	Reference electrical life graph		
Installation	Fixed		H, P type		
Applicable standard			IEEE Std C37.09, ANSI C37.54		
UL Certificate			UL Listed		

Technical data

Electrical endurance by interrupting current

Rated voltage		4.76kV				15kV				27kV			38kV	
Ir [A]	Isc [kA]	25	31.5	40	50	25	31.5	40	50	25	31.5	40	31.5	40
1200		LV5(UVM) LV6(UVL)	LV6 (UVL, UVM)	LV10 (UVH)	LV8 (UVH)	LV5(UVM) LV6(UVL)	LV6 (UVL, UVM)	LV10 (UVH)	LV8 (UVH)	LV14-P1 (UVM)	LV7-P1 (UVH)	LV7-P1 (UVH)	LV8 (UVH)	LV8 (UVH)
2000		LV5(UVM) LV6(UVL)	LV6 (UVL, UVM)	LV10 (UVH)	LV8 (UVH)	LV5(UVM) LV6(UVL)	LV6 (UVL, UVM)	LV10 (UVH)	LV8 (UVH)	LV14-P1 (UVM)	LV7-P1 (UVH)	LV7-P1 (UVH)	LV8 (UVH)	LV8 (UVH)
2500										LV7-P1 (UVH)	LV7-P1 (UVH)	LV7-P1 (UVH)		
2750										LV7-P1 (UVH)	LV7-P1 (UVH)	LV7-P1 (UVH)		
3000		LV8 (UVH)	LV8 (UVH)	LV8 (UVH)	LV8 (UVH)	LV8 (UVH)	LV8 (UVH)	LV8 (UVH)	LV8 (UVH)				LV8 (UVH)	LV8 (UVH)
4000		LV8 (UVH)	LV8 (UVH)	LV8 (UVH)	LV8 (UVH)	LV8 (UVH)	LV8 (UVH)	LV8 (UVH)	LV8 (UVH)					

- : UVL/UVM-05/15 UL certified
- : UVL-27 UL certified
- : UVH-05/15 UL certified
- : UVH-27 UL certified
- : UVH-38 UL certified
- : Not available

VI Model	Page	VI Model	Page
LV5	210	LV8	211
LV6	210	LV10	211
LV7-P1	211	LV14-P1	211

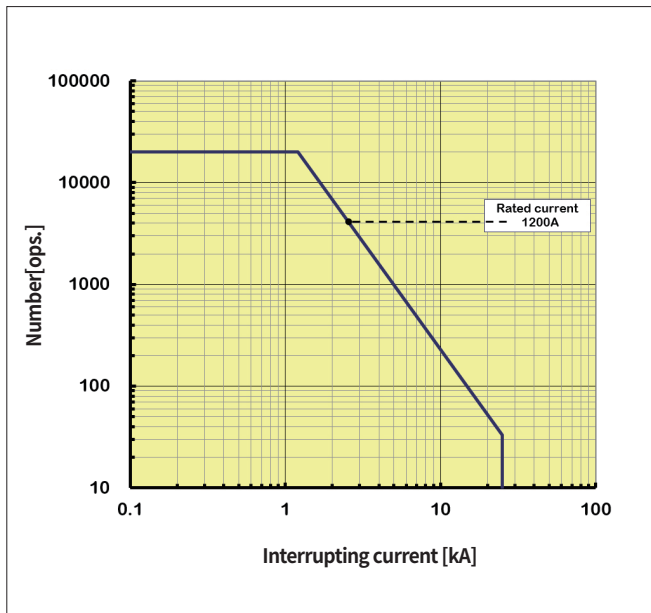

VI Model : LV5

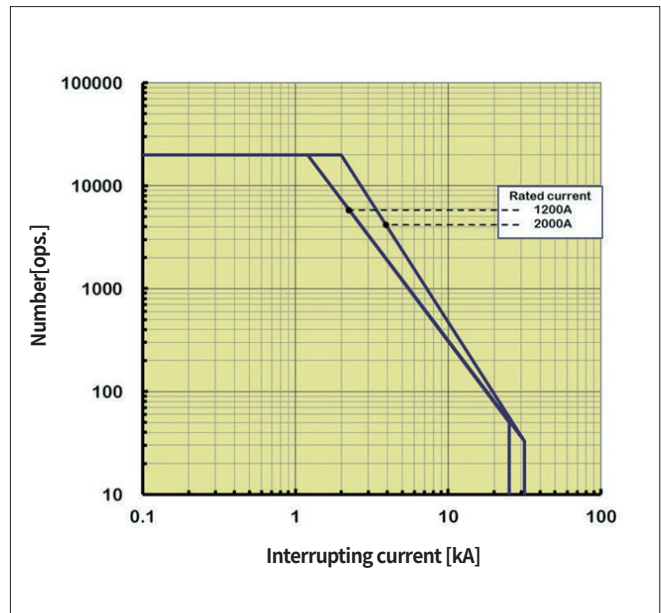

VI Model : LV6

Note) 1. Above graphs represent the characteristics of the electrical life of LS Susol VCB.
 2. Life characteristics of each model in each rating represents the LOG-LOG graphs.

Electrical endurance by interrupting current

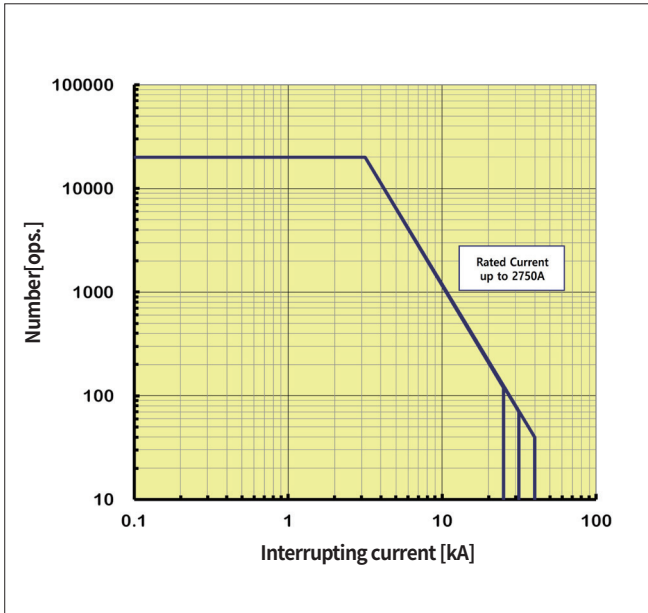

VI Model : LV7-P1

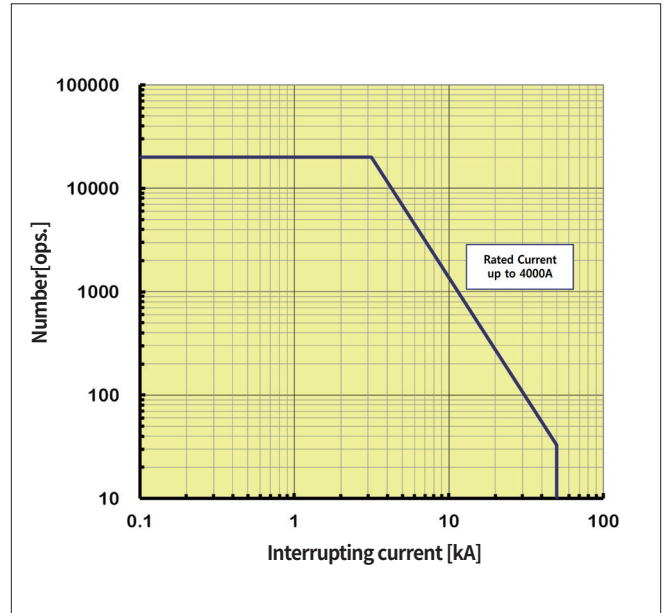

VI Model : LV8

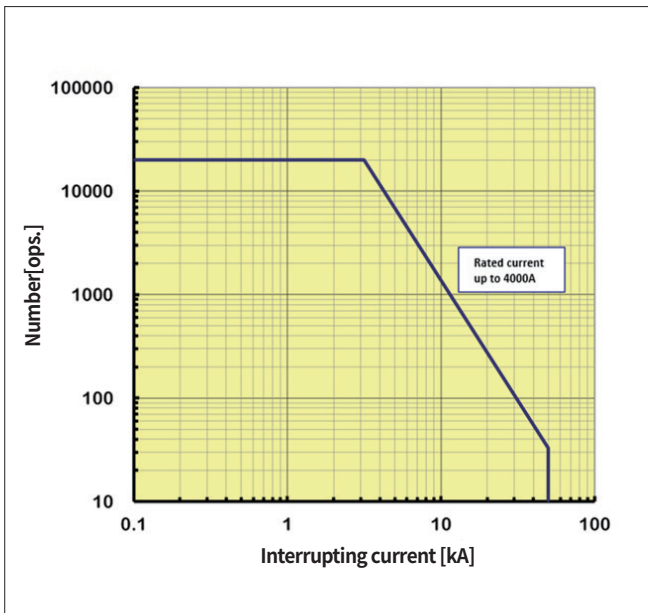

VI Model : LV10

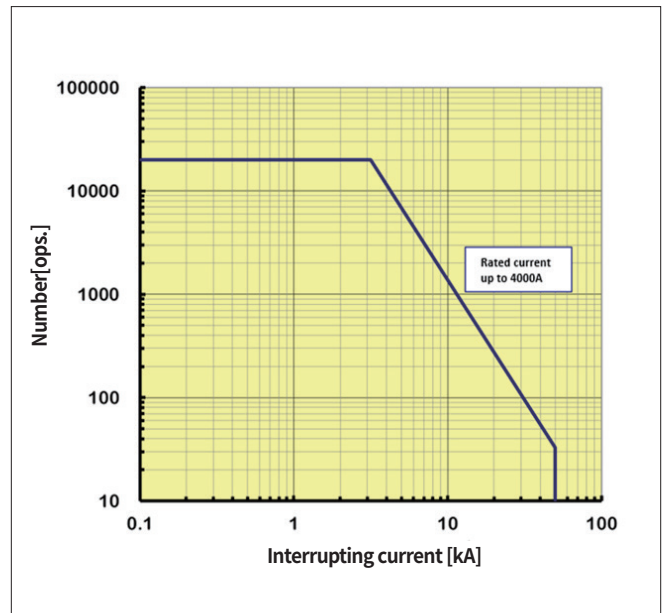

VI Model : LV14-P1

Note) 1. Above graphs represent the characteristics of the electrical life of LS Susol VCB.
 2. Life characteristics of each model in each rating represents the LOG-LOG graphs.

Basic functions

Manual operation

① Manual Charge

- a) UVM type: Operate the charge handle 7–8 times through a full stroke.
- b) UVH type: Insert the charge handle into the handle slot first. Rotate the handle clockwise more than 40 times, and the charge will be complete with a click sound.
- When the closing spring is fully charged, "CHARGED" is displayed on the charge indicator.

② Manual Closing

- a) Press the CLOSE button to close the breaker.
- b) Upon closing the breaker, "CLOSE" is displayed on the CLOSED/OPEN indicator and "DISCHARGED" on the charge indicator.

③ Manual Trip

- a) Press the OPEN button to open the breaker.
- b) "OPEN" is displayed on the CLOSED/OPEN indicator.

Electric operation

① Electric Charge

The breaker is closed remotely by charging the closing spring. If the breaker trips, the closing spring is automatically charged by gear motors.

② Electric Closing

Remote closing is operated by the closing coil.

③ Electric Trip

Remote trip is operated by the trip coil or UVT coil.

Note) UVT is not equipped as standard and requires additional option selection.

Main contacts are operated by the energy stored in the spring mechanism, and the closing spring is charged by a motor in the mechanism.

The breaker is closed by the closing coil and tripped by the trip coil.

These operations are repeated in the VCB as shown in the sequence chart below.

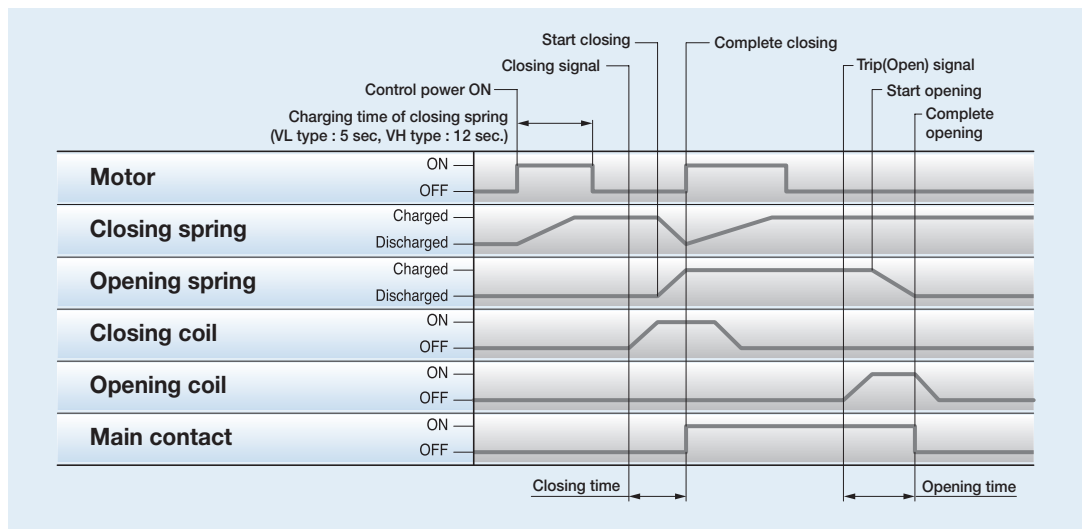

Sequence of the switching mechanism

Vacuum interrupter interruption

The interruption of the VCB is carried out by vacuum interrupters.

The interrupter contacts, a key component, are made of copper-chromium (CuCr) material with a spiral shape, which provides low contact wear and excellent withstand voltage characteristics.

The spiral contacts cause the arc generated between the contact surfaces to rotate around the contact surface due to the induced magnetic field created by the spiral structure. This rotation prevents local heating and contact damage, allowing instantaneous interruption.

The vacuum pressure inside the vacuum interrupter (VI) is very high (approximately 5×10^{-5} Torr), and the spacing between the fixed and movable contacts is about 6 to 20 mm, depending on the voltage.

The contacts are designed so that arcs can be easily extinguished. The contact surfaces are made of a special copper-chromium alloy, and the interior is completely sealed to prevent vacuum loss.

Therefore, contact wear is minimized during short-circuit events, and arc energy caused by over voltage or switching can be effectively reduced.

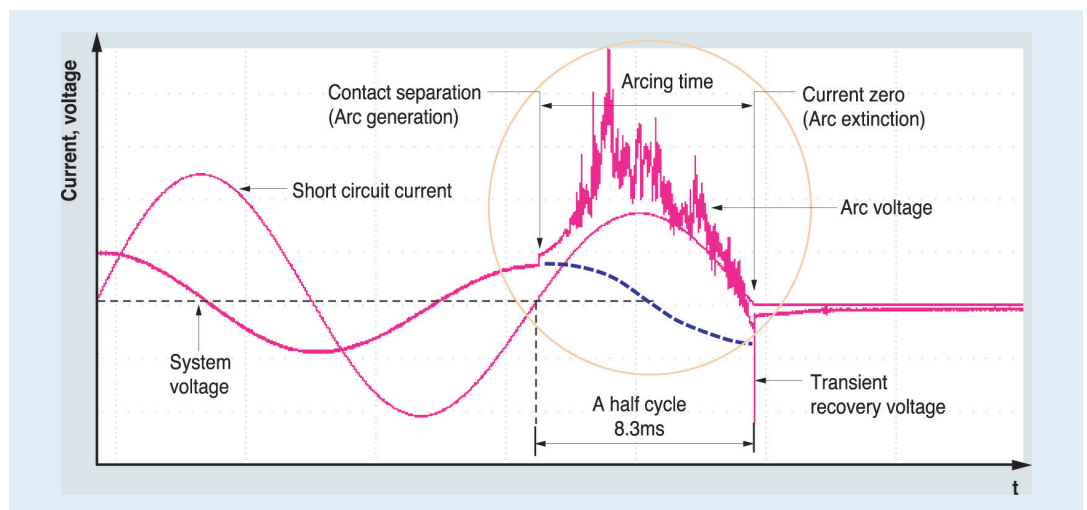
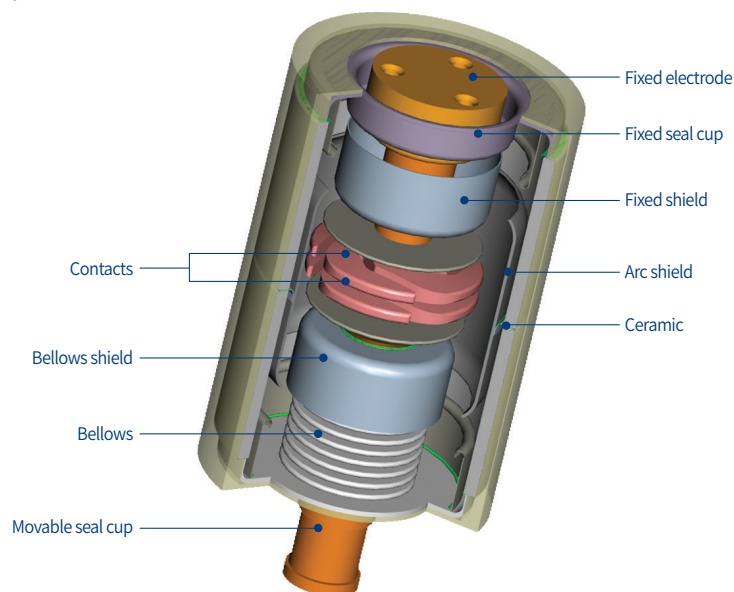

An example of oscillogram obtained through the interrupting test using LC resonant circuit

Basic functions and interrupting operation

The interruption of vacuum interrupters

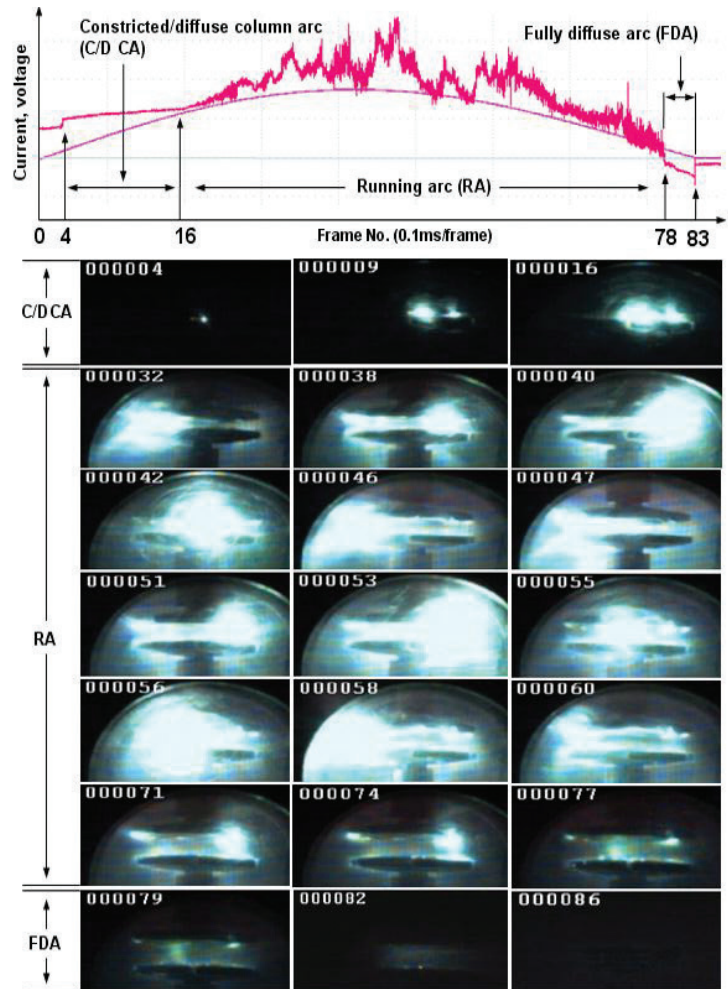

Arc voltage waveforms and arc image captured during arcing time

When using flat contacts, neither design prevents the arc from contracting and fixing at the center of the contacts during opening. This phenomenon, caused by the high temperature arc, is called the pinch effect. To prevent this effect, two types of contact shapes have been designed:

- One uses an axial magnetic field that spreads the arc before contraction.
 - The other uses a radial magnetic field that allows the arc to contract but makes it rotate to disperse its energy.
- Because the contracted arc is shaped like a cylinder, it is called a contracted arc or columnar arc.

The spiral contact structure utilizes the force ($F = j \times B$) generated by the interaction of the radial magnetic field and the current flowing through the arc between two contacts. This force rotates the arc, which would otherwise contract due to the pinch effect, thereby dispersing arc energy evenly across the contact surface and minimizing contact damage.

The images below show arc behavior during an arcing time of approximately 8 ms, captured with a high-speed camera capable of 10,000 frames per second (0.1 ms per frame).

They focus on specific segments of the arcing period shown in the graph above, and the simultaneously measured arc voltage is also presented to illustrate the arc condition in each section.

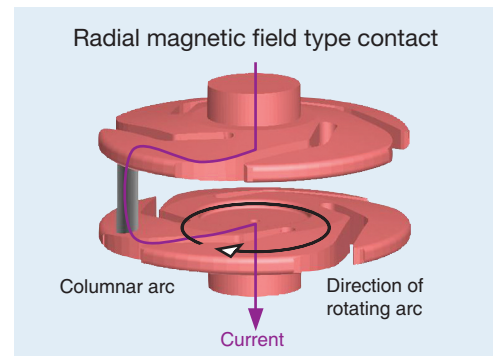

Arc driving principle in the contacts of radial magnetic field

Standards and certification

The Susol VCB has been type-tested and certified in accordance with the latest IEEE/ANSI standards at an international testing laboratory. It is suitable for installation and application in environments and conditions as specified by the standards.

- **Standard**
 - IEEE Std C37.09, ANSI C37.54, UL Listed & CSA
- **Test and certification**
 - Test report (KERI)

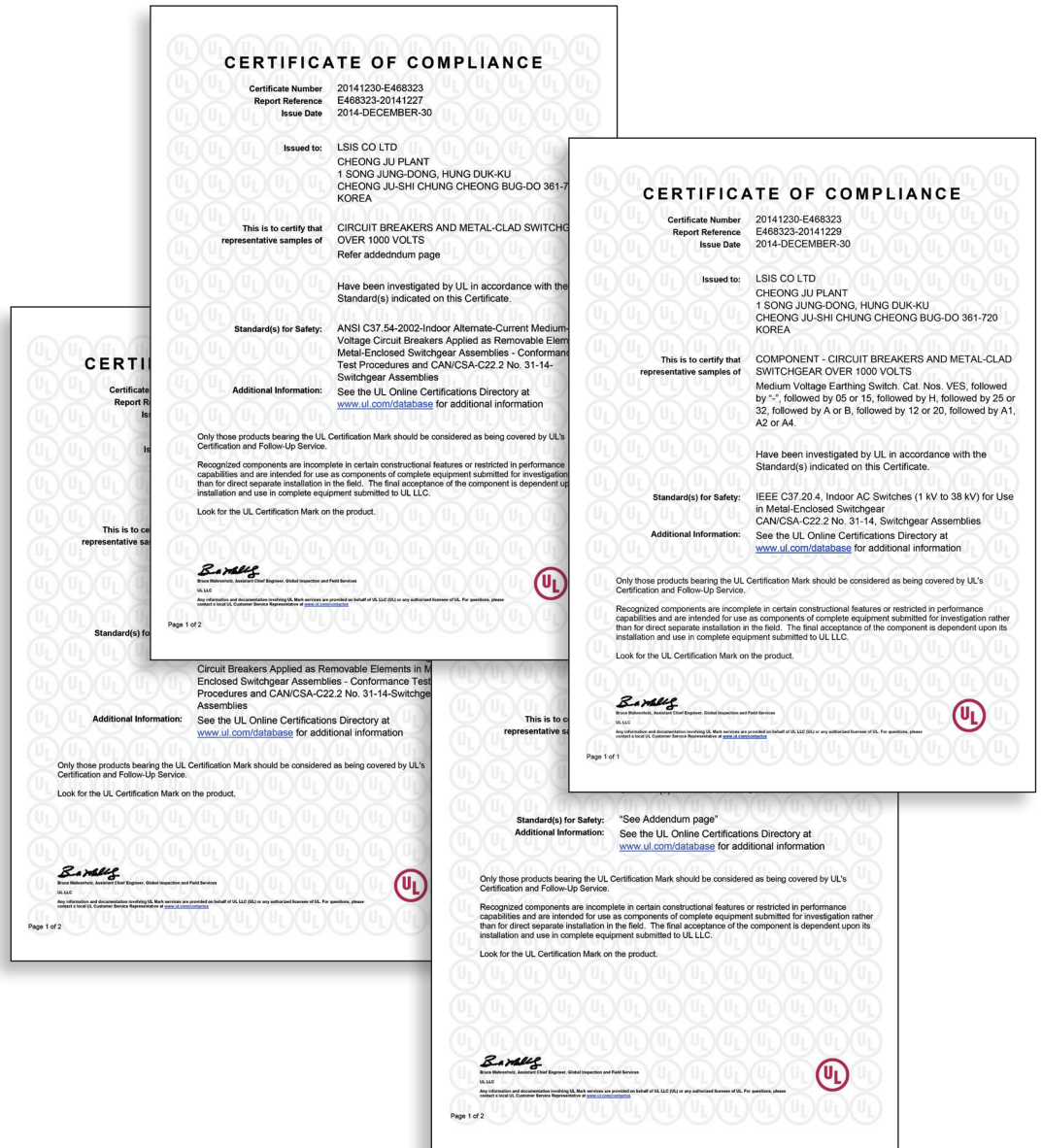

Standard Use Environment for Susol VCB

The operating characteristics of a vacuum circuit breaker—such as insulation and endurance—are significantly affected by external environmental conditions. Therefore, the breaker must be applied appropriately, taking into consideration the conditions of the installation site.

The following values represent the standard limits specified in accordance with IEEE C37.04:

Ambient Temperature

- Maximum temperature: +40°C
- 24-hour average maximum temperature: +35°C
- Minimum temperature: -5°C

Altitude

- 1000m or less above sea level

Relative Humidity

- 24-hour average: 95% or less
- One-month average: 90% or less

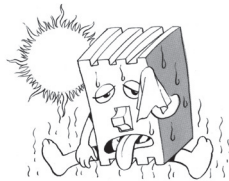

- If a standard circuit breaker is used in temperatures exceeding 40°C, it is recommended to apply the current correction values provided in the catalog based on the ambient temperature level.
- In conditions of high humidity, dielectric strength and electrical performance may be degraded.

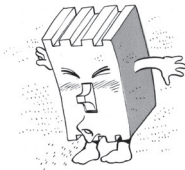

- It is highly recommended to use a dust cover or anti-humidity agent in dusty or humid environments.
- Excessive vibration may cause the breaker to trip due to connection faults or mechanical defects.



- If the breaker remains in the CLOSE or OPEN position for an extended period, it is recommended to switch load current regularly.
- If corrosive gases are present, it is recommended to install the breaker in sealed protection.

Special Use Environment

The circuit breaker is designed for use in the standard environment specified in Section 4.1 of IEEE C37.04. For the special environments listed below, special usage conditions must be considered. In such cases, please contact us in advance.

- When the altitude or ambient temperature exceeds standard use conditions (e.g., below -30°C)
- In areas affected by strong sea breeze
- In consistently humid environments
- Where steam or oil mist is present
- Where explosive, flammable, or other harmful gases may permeate the breaker
- In dusty environments
- Where abnormal vibration or shock is present
- In areas with heavy ice or snow accumulation
- Other special environmental conditions

Withstand voltage compensation according to altitude

If the breaker is used in areas above 1000m above sea level, degradation of insulation performance should be taken into consideration.

	80	38	150
	60	27	125
	36	15	95
	19	4.76	60
Ud [kV/1min]		Ur[kV]	Up [kV/1.2 × 50μs]
Power Frequency Withstand Voltage			Impulse Withstand Voltage

<Table 1> Criteria of withstand voltages by rated voltages specified in IEEE C37.04

Special Use Environment

Withstand voltage compensation according to altitude

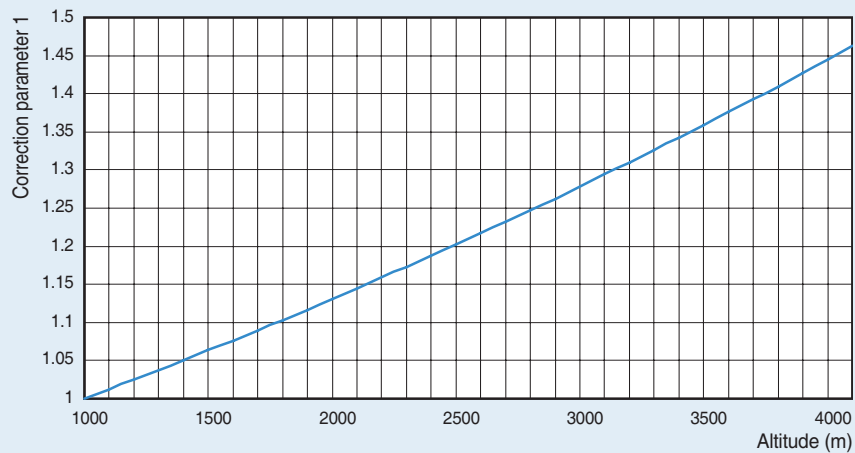

<Fig.1> withstand voltage correction parameter 1 by altitude (based on a required withstand voltage)

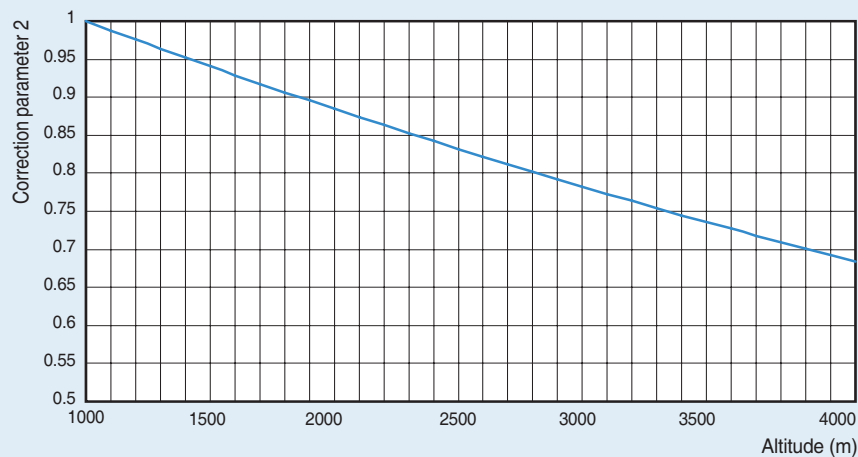

<Fig.2> withstand voltage correction parameter 2 by altitude (based on a applicable withstand voltage)

Ex 1) Selecting a breaker to be used at an altitude of 2,500 m above sea level with a rated voltage of 4.76 kV (Correction parameter 1 applied)

- Correction parameter at 2,500 m: 1.2
 - Withstand voltage criteria based on rated voltage:
 - Power Frequency Withstand Voltage (U_d) = 19 kV
 - Impulse Withstand Voltage (U_p) = 60 kV
 - Required withstand voltage after correction:
 - Power Frequency Withstand Voltage (U_d) = $19 \times 1.2 = 22.8$ kV
 - Impulse Withstand Voltage (U_p) = $60 \times 1.2 = 72$ kV
- Therefore, a breaker with a rated voltage of 15 kV shall be applied to satisfy the required withstand voltage.

Ex 2) Applying a breaker with a rated voltage of 15 kV at an altitude of 2,500 m above sea level (Correction parameter 2 applied)

- Correction parameter at 2,500 m: 0.825
 - Dielectric strength of the VCB:
 - Power Frequency Withstand Voltage (U_d) = $36 \times 0.825 = 29.7$ kV
 - Impulse Withstand Voltage (U_p) = $95 \times 0.825 = 78.4$ kV / 1.2 \times 50 μ s
- Therefore, the above breaker with a rated voltage of 15 kV can be applied to a rated voltage system of 4.76 kV at this altitude.

Rated current compensation in accordance with ambient temperature

When the normal ambient temperature exceeds the temperature specified for the environment, the following formula can be used to select the applicable current.

$$I_a = I_r \left(\frac{\Theta_{max} - \Theta_a}{\Theta_r} \right)^{1/2}$$

- I_a: allowable continuous current in the actual ambient temperature Θ_a
- I_r: rated current at 40°C ambient temperature
- Θ_{max}: acceptable overall temperature of the hottest spot
- Θ_a: the actual ambient temperature expected at -30°C and 60°C
- Θ_r: allowable temperature in the hottest place at rated current

Ex) The calculation of the applicable load current value when a breaker with rated current 2000A is used at 55 °C ambient temperature
 $I_a = 2000 \times ((105-55)/65)^{1/2} = 2000 \times 0.87 = 1754A$

Rated current (A)	Ambient temperature (°C)									
	20	25	30	35	40	45	50	55	60	
4000	4000	4000	4000	4000	4000	3843	3679	3508	3328	
3000	3000	3000	3000	3000	3000	2882	2760	2631	2496	
2750	2750	2750	2750	2750	2750	2642	2530	2412	2288	
2500	2500	2500	2500	2500	2500	2420	2300	2193	2080	
2000	2000	2000	2000	2000	2000	1922	1840	1754	1664	
1200	1200	1200	1200	1200	1200	1153	1104	1052	998	

<Table 2> Allowable load current by ambient temperature

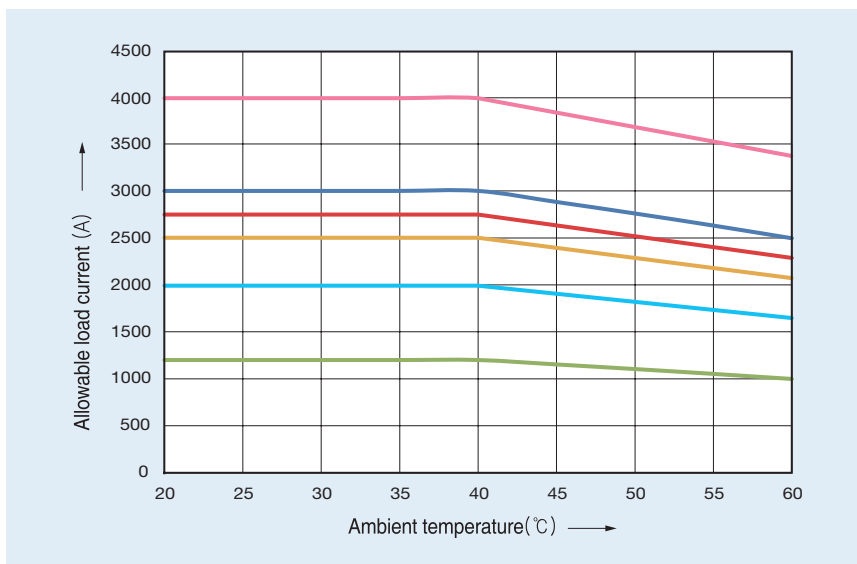

<Figure 3> Allowable load current by ambient temperature

DIGITAL SUPPORT HUB

***SCAN THE QR CODE FOR INSTANT PRODUCT
INFORMATION AND EXPERT SUPPORT***

BeyondX™
Beyond Expectations



LSE LENS



**Product
Finder**



**Download
Center**



**Tech Hub-
Youtube**



**One Scan,
More Materials**

Scan the QR code to instantly
access product materials



**Search Smarter.
Find Faster**

Quickly discover the best-fit
product for your needs



**Download with
Ease and Speed**

Instantly access datasheets,
manuals, and CAD files



**Expert Guidance,
Now on YouTube**

Watch trusted tutorials and
product guides from real experts





LS ELECTRIC America Inc. Chicago Head Office

625 Heathrow Dr, Lincolnshire, IL 60069, USA

Tel: 1-224-352-2265 E-Mail: sales.us@lselectricamerica.com

Headquarter

127 LS-ro (Hogye-dong) Dongan-gu, Anyang-si, Gyeonggi-Do, 14119, Korea

Seoul Office

LS Yongsan Tower, 92, Hangang-daero, Yongsan-gu, Seoul, 04386, Korea

TEL: 82-2-2034-4916, 4684, 4429

China

LS ELECTRIC (Dalian) Co., Ltd.

+86-411-8730-7560

china.dalian@lselectric.com.cn

LS ELECTRIC (Wuxi) Co., Ltd.

+86-510-8534-6666

china.wuxi@lselectric.com.cn

LS ELECTRIC (Lishui) Co., Ltd.

+86-133-6207-7980

china.lishui@lselectric.com.cn

Shanghai Office

+86-21-5237-9977

china@lselectric.com.cn

Beijing Office

+86-10-5095-1631

china@lselectric.com.cn

Guangzhou Office

+86-20-3818-2883

china@lselectric.com.cn

Qingdao Office

+86-532-8501-2065

china@lselectric.com.cn

Chengdu Office

+86-28-8670-3201

china@lselectric.com.cn

Nanjing Office

+86-25-8467-0005

china@lselectric.com.cn

India

India Office

+91-80-6142-9108

Info_india@ls-electric.com

Indonesia

PT. LS ELECTRIC INDONESIA

+62-21-2933-7614

indonesia@ls-electric.com

PT SYMPHOS ELECTRIC

+62-81-1900-1474

marketing@symphos-weltraf.com

Italy

Italy office

+39-030-8081-833

italia@ls-electric.com

Japan

LS ELECTRIC Japan Co., Ltd.

+81-3-6268-8241

japan@ls-electric.com

Tokyo Office

+81-3-6268-8241

tokyo@ls-electric.com

Netherlands

LS ELECTRIC Europe B.V.

+31-20-654-1424

europartner@ls-electric.com

Russia

Moscow Office

+7-499-682-6130

info@lselectric-ru.com

Singapore

Singapore Office

+65-6958-8162

singapore@ls-electric.com

Spain

LS ELECTRIC IBERIA S.L.U.

+34-910-28-02-74

iberia@ls-electric.com

Thailand

Bangkok Office

+66-2-128-0295

thailand@ls-electric.com

Türkiye

LS ELECTRIC Türkiye Co., Ltd.

+90-212-806-1252

turkiye@ls-electric.com

U.A.E

LS ELECTRIC Middle East FZE (Dubai)

+971-4-886-5360

middleeast@ls-electric.com

USA

LS ELECTRIC America Inc.

+1-800-891-2941

sales.us@lselectricamerica.com

LS ENERGY SOLUTIONS LLC

+1-980-221-0654

cmfeldman@ls-es.com

MCM Engineering II

+1-435-865-0125

sales.us@lselectricamerica.com

America Western Office

+1-949-333-3140

america@ls-electric.com

America Bastrop Campus

+1-224-352-2265

sales.us@lselectricamerica.com

Vietnam

LS ELECTRIC Vietnam Co., Ltd.

+84-222-2221-110

vietnam@ls-electric.com

Hanoi Sales Office

+84-24-6275-8054

vietnam@ls-electric.com

Ho Chi Minh Sales Office

+84-3823-7890

vietnam@ls-electric.com

Specifications in this catalog are subject to change without notice due to continuous product development and improvement

© 2022. 06 LS ELECTRIC Co., Ltd. All rights reserved. / English (10) 2025. 12 Staffcom

www.LSElectricAmerica.com